



US00D458943S

(12) **United States Design Patent**
Briggs et al.

(10) **Patent No.:** **US D458,943 S**
(45) **Date of Patent:** **** Jun. 18, 2002**

(54) **TRACTOR PORTION OF AN ARTICULATED WORK MACHINE**

(75) Inventors: **Robert W. Briggs**, Washington; **Gary C. Bryant**, Chillicothe; **Kolin J. Kirschenmann**, Decatur, all of IL (US); **Ian McCulloch**, Cleveland; **William Pack**, South Shields, both of (GB); **Larry T. Ryterski**, Decatur, IL (US)

(73) Assignee: **Caterpillar S.A.R.L.**, Geneva (CH)

(**) Term: **14 Years**

(21) Appl. No.: **29/120,991**

(22) Filed: **Mar. 30, 2000**

(51) **LOC (7) Cl.** **15-03**

(52) **U.S. Cl.** **D15/30**

(58) **Field of Search** D15/30, 10, 22-26;
296/190, 192; 180/89.12; D12/96

(56) **References Cited**

U.S. PATENT DOCUMENTS

D144,083 S	*	3/1946	Swanson	D15/30
D267,486 S	*	1/1983	Martin, Jr.	D15/30
D297,329 S	*	8/1988	Monehaie et al.	D15/30
D307,203 S	*	4/1990	Martinez	D15/30

* cited by examiner

Primary Examiner—Mitchell Siegel

(74) *Attorney, Agent, or Firm*—John J. Cheek

(57) **CLAIM**

The ornamental design for a tractor portion of an articulated work machine, as shown and described.

DESCRIPTION

FIG. 1 is a perspective view showing the front, top and right side of a tractor portion of an articulated work machine having our new design;

FIG. 2 is a right side elevational view thereof, the broken line showing of the trailer is for illustrative purposes only and forms no part of the claimed design;

FIG. 3 is a right side elevational view thereof;

FIG. 4 is a left side elevational view thereof;

FIG. 5 is a top plan view thereof;

FIG. 6 is a front elevational view thereof;

FIG. 7 is a rear elevational view thereof;

FIG. 8 is a perspective view showing the front, top, and right side of a second embodiment of a tractor portion of an articulated work machine having our new design;

FIG. 9 is a right side elevational view of FIG. 8, the broken line showing of the trailer is for illustrative purposes only and forms no part of the claimed design;

FIG. 10 is a right side elevational view of FIG. 8;

FIG. 11 is a left side elevational view of FIG. 8;

FIG. 12 is a top plan view of FIG. 8;

FIG. 13 is a front elevational view of FIG. 8; and,

FIG. 14 is a rear elevational view of FIG. 8.

The bottom surface does not form part of the claimed design and therefore is not disclosed.

The broken line showing is for illustrative purposes only and forms no part of the claimed design.

1 Claim, 14 Drawing Sheets

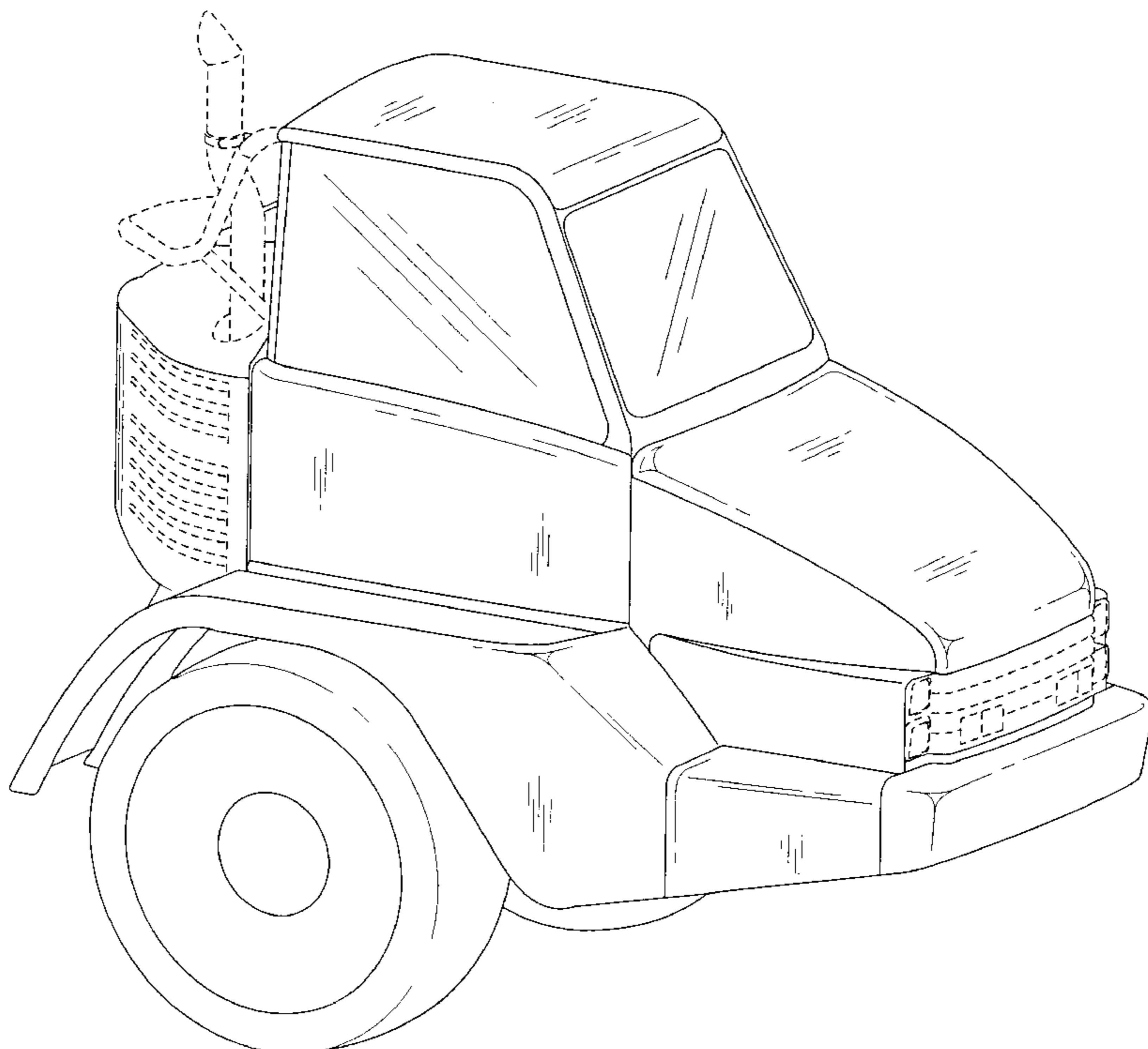

FIG. 1

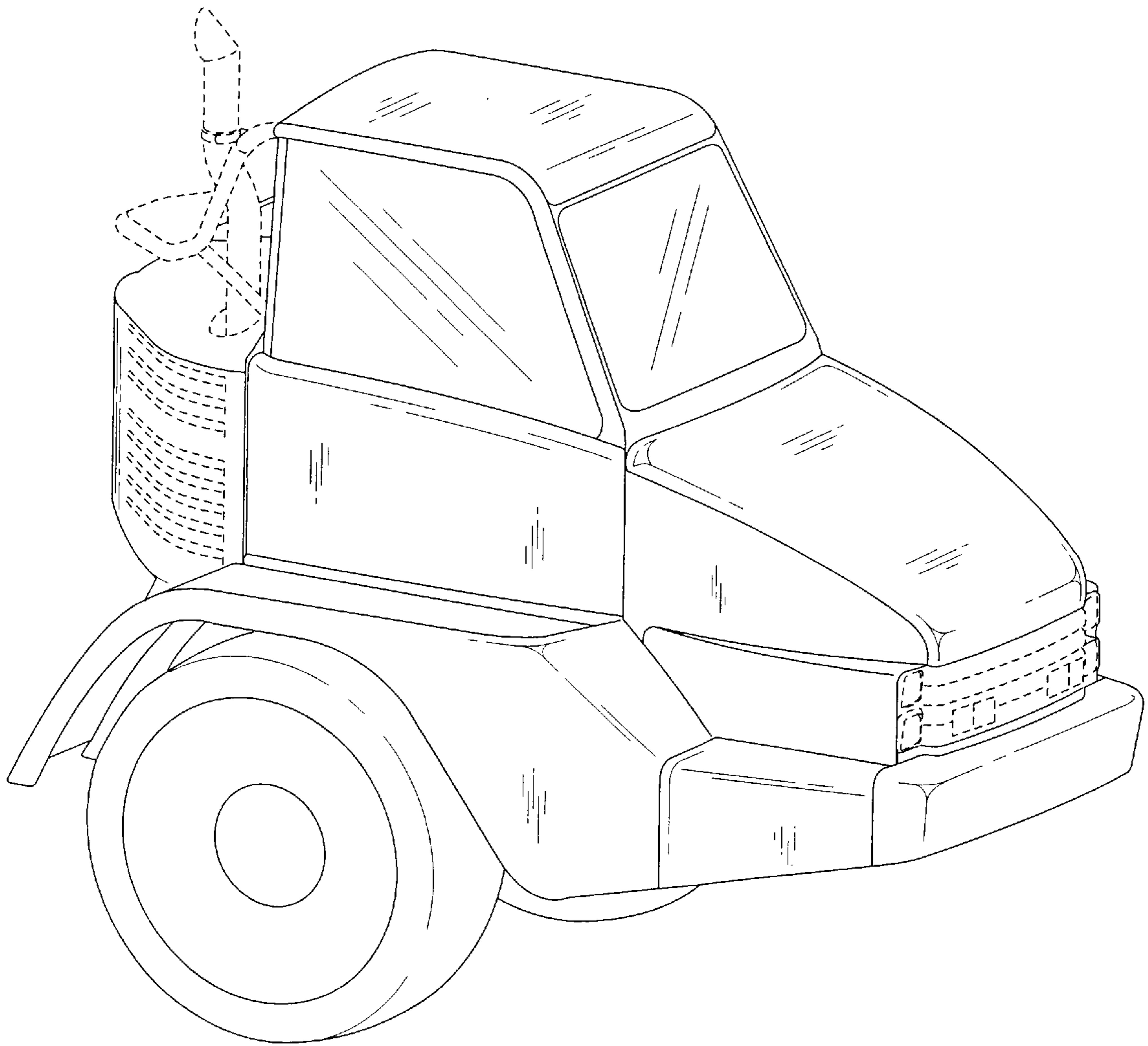

FIG. 2

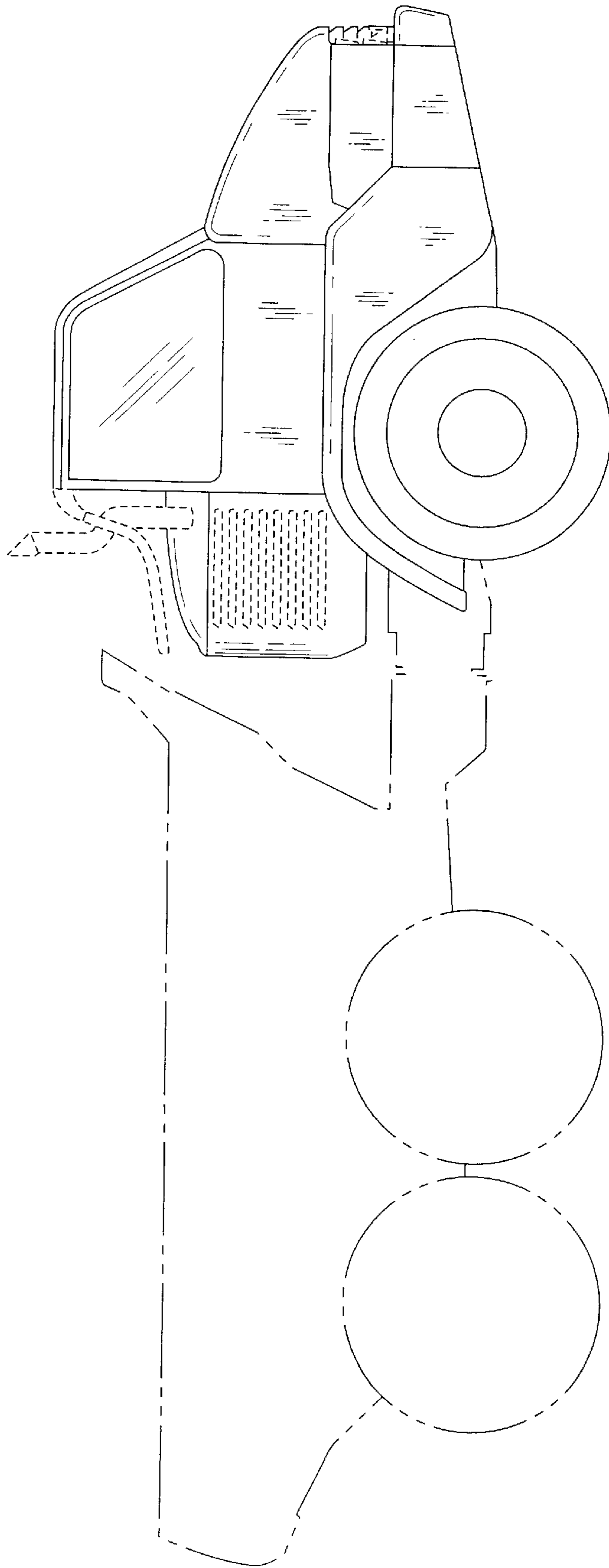

FIG. 3.

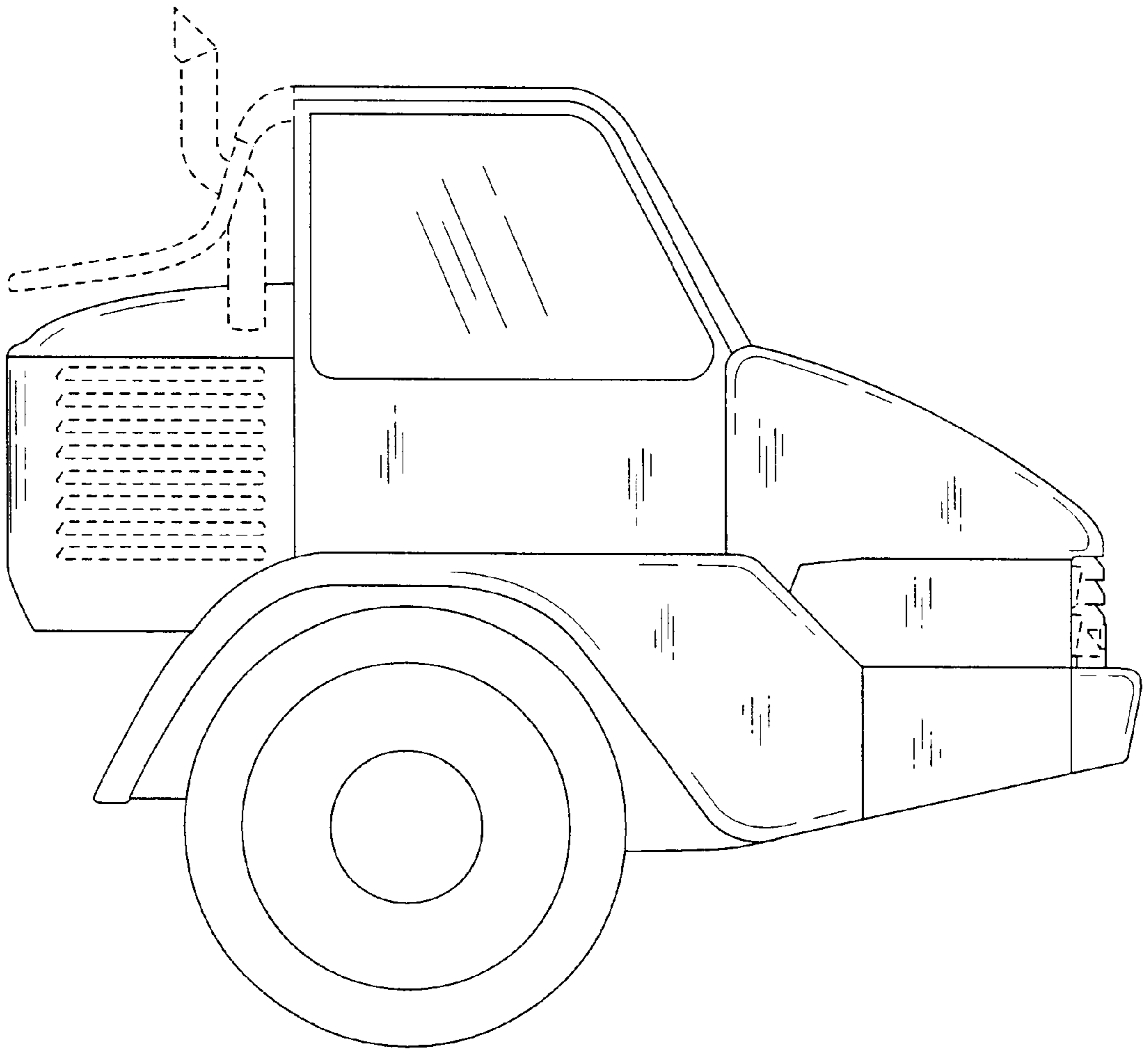

FIG. 4.

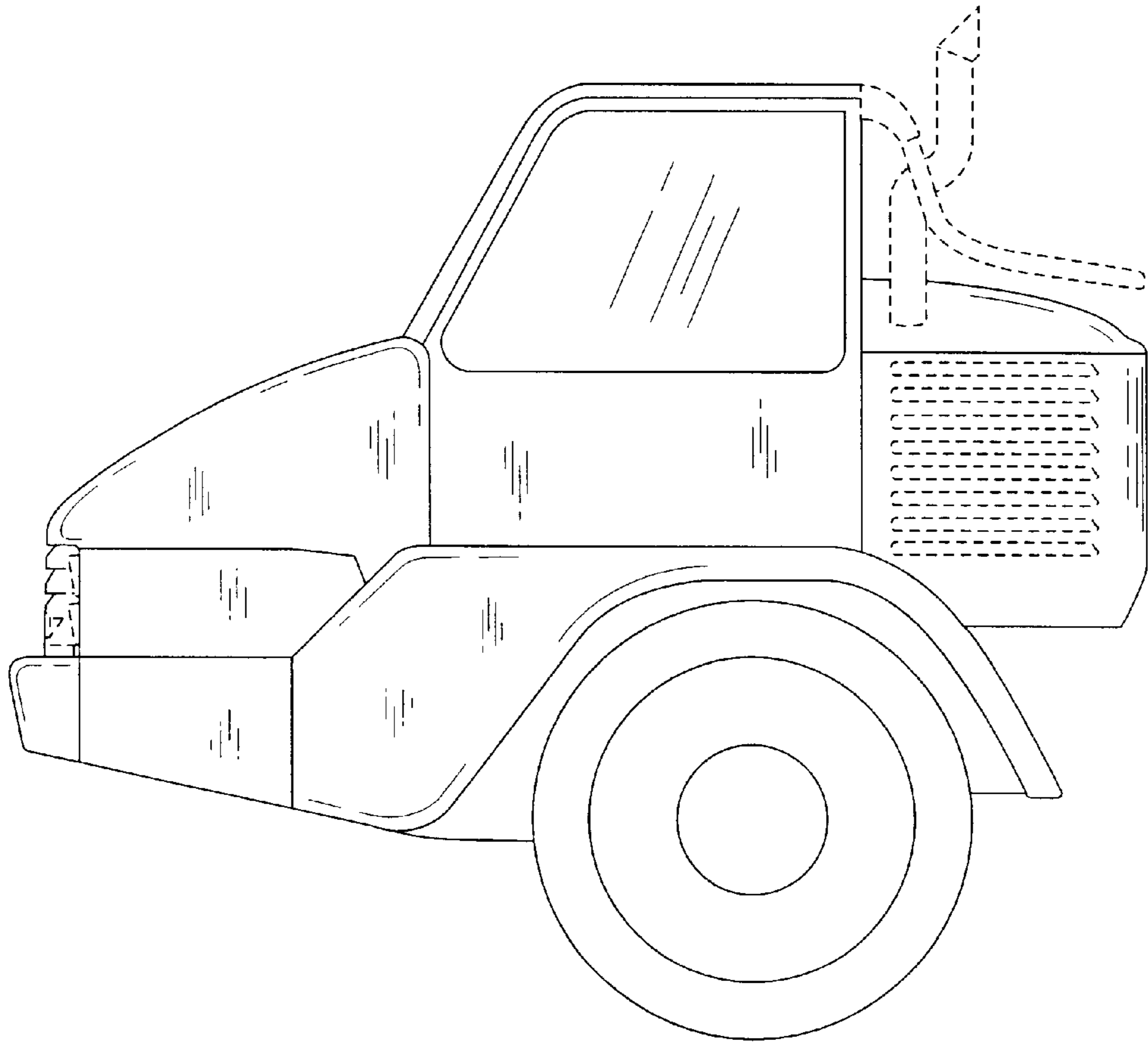

FIG. 5.

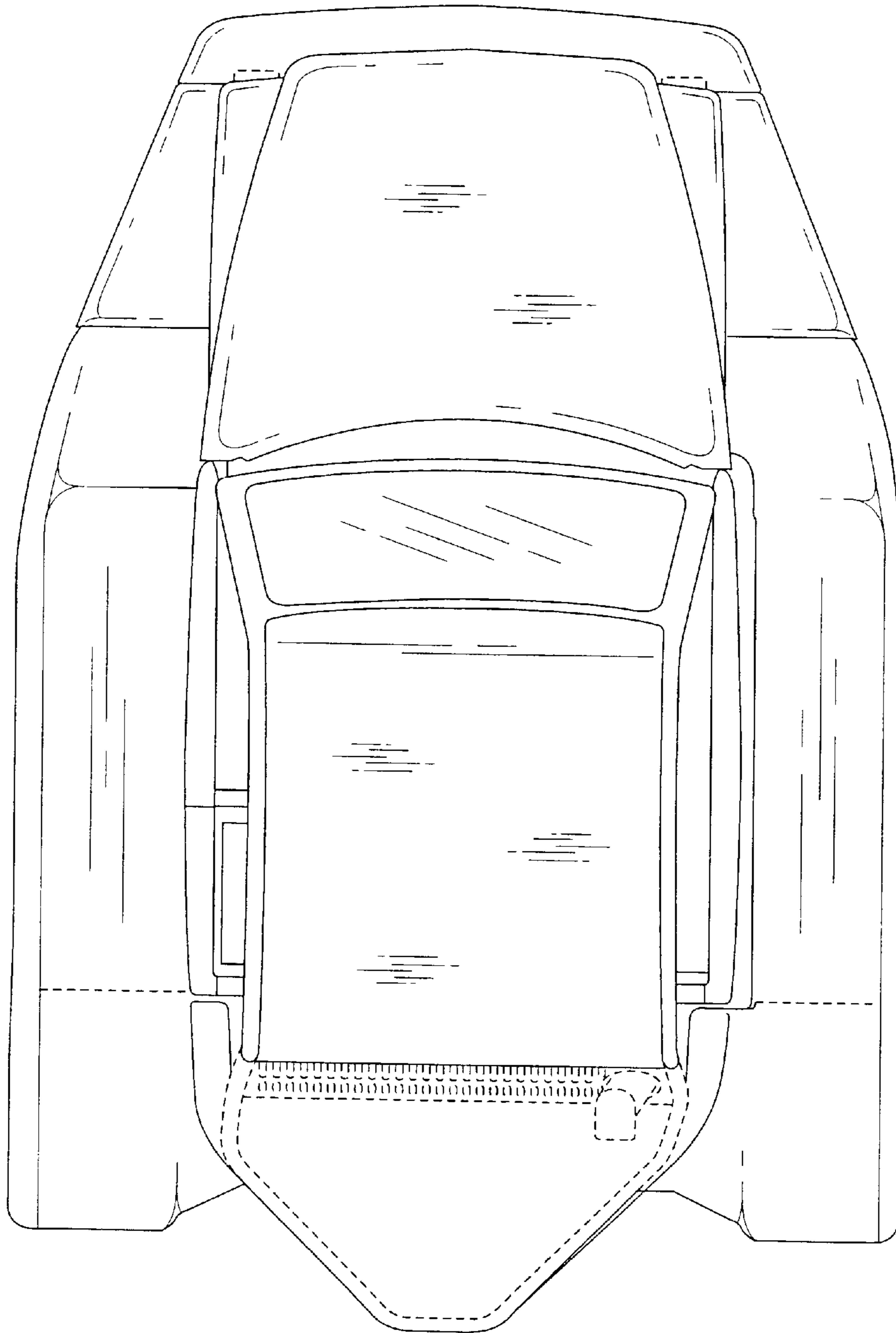

FIG. 6.

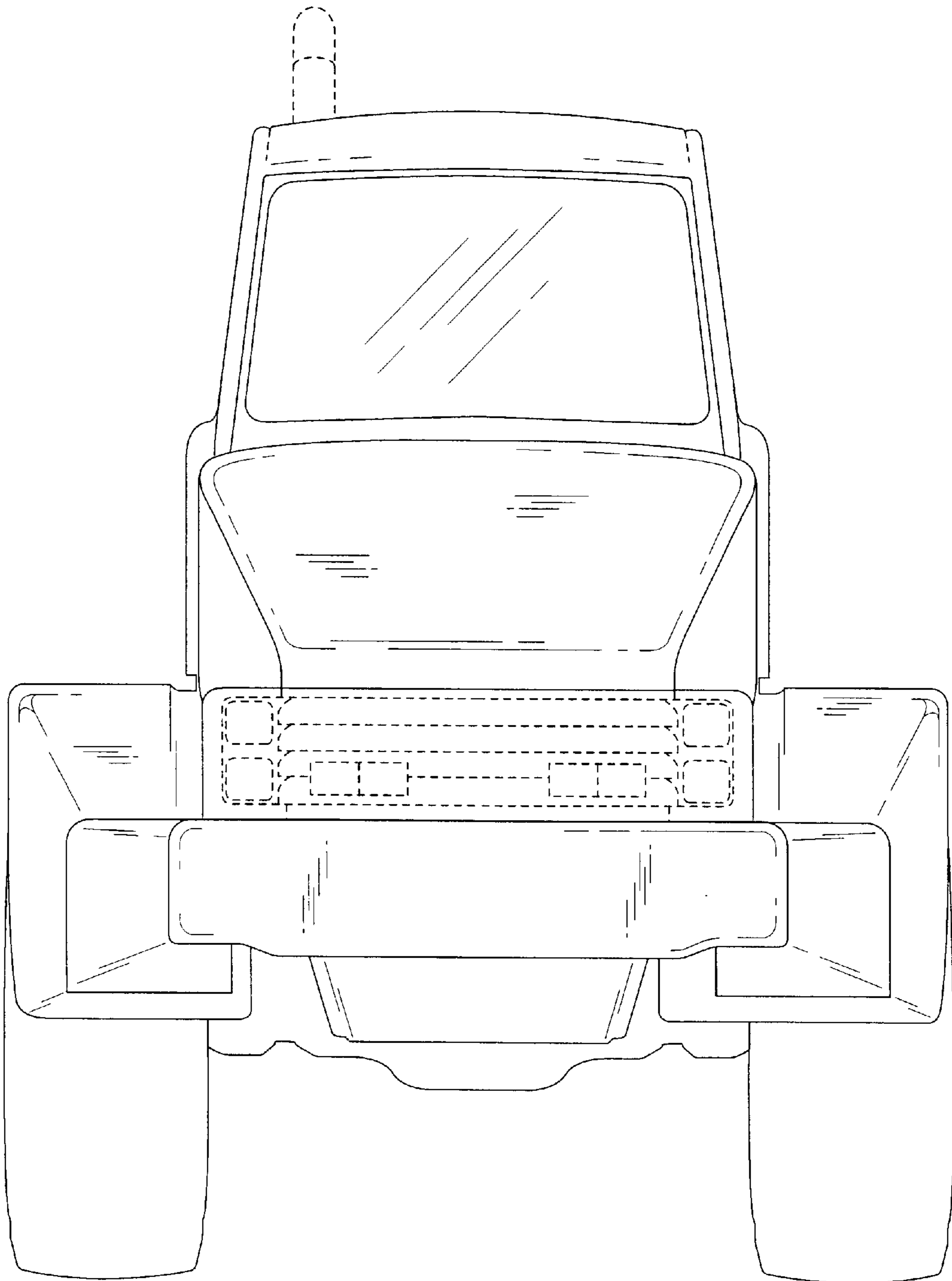

FIG. 7.

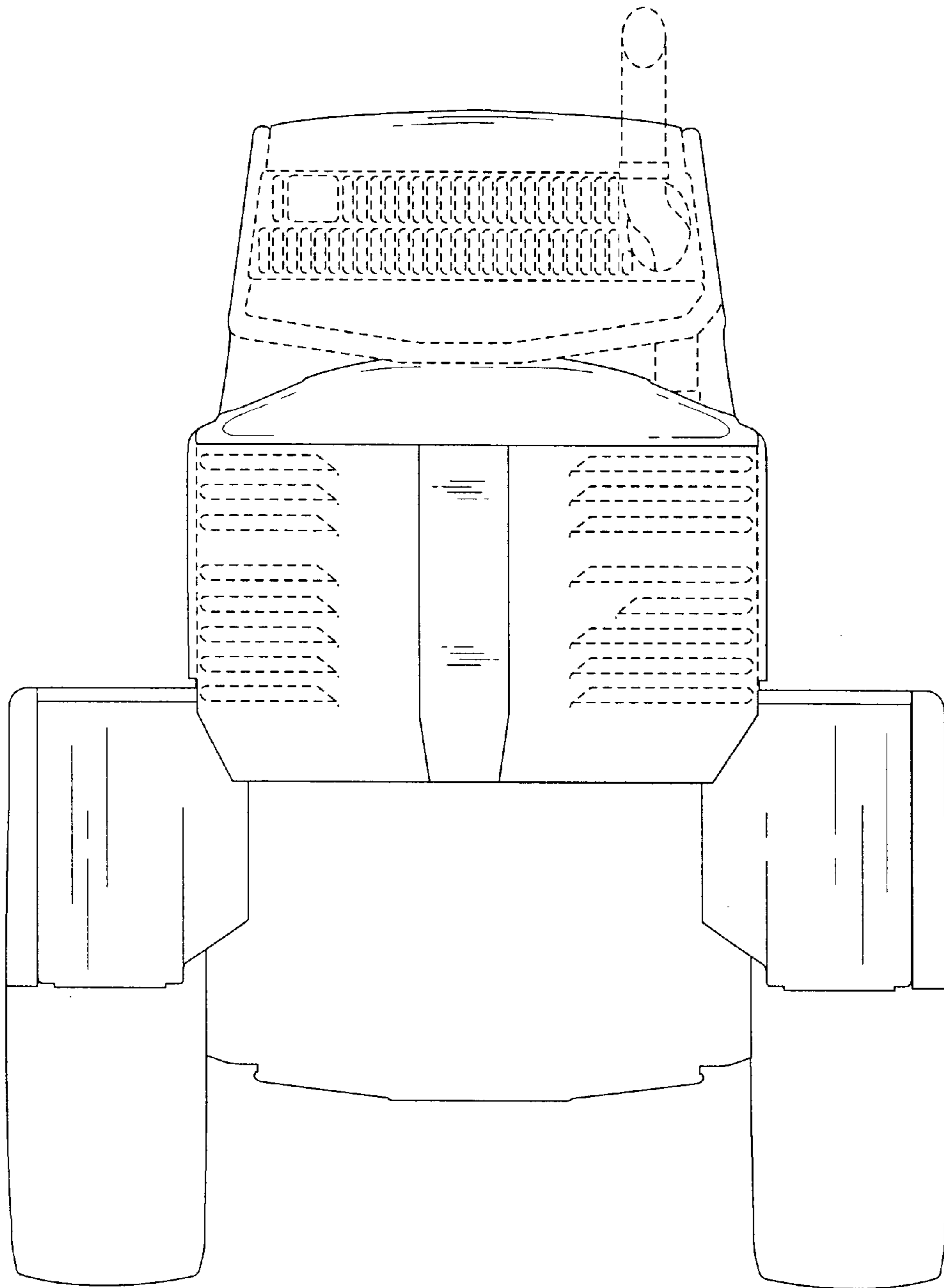

FIG. 8 - 8 -

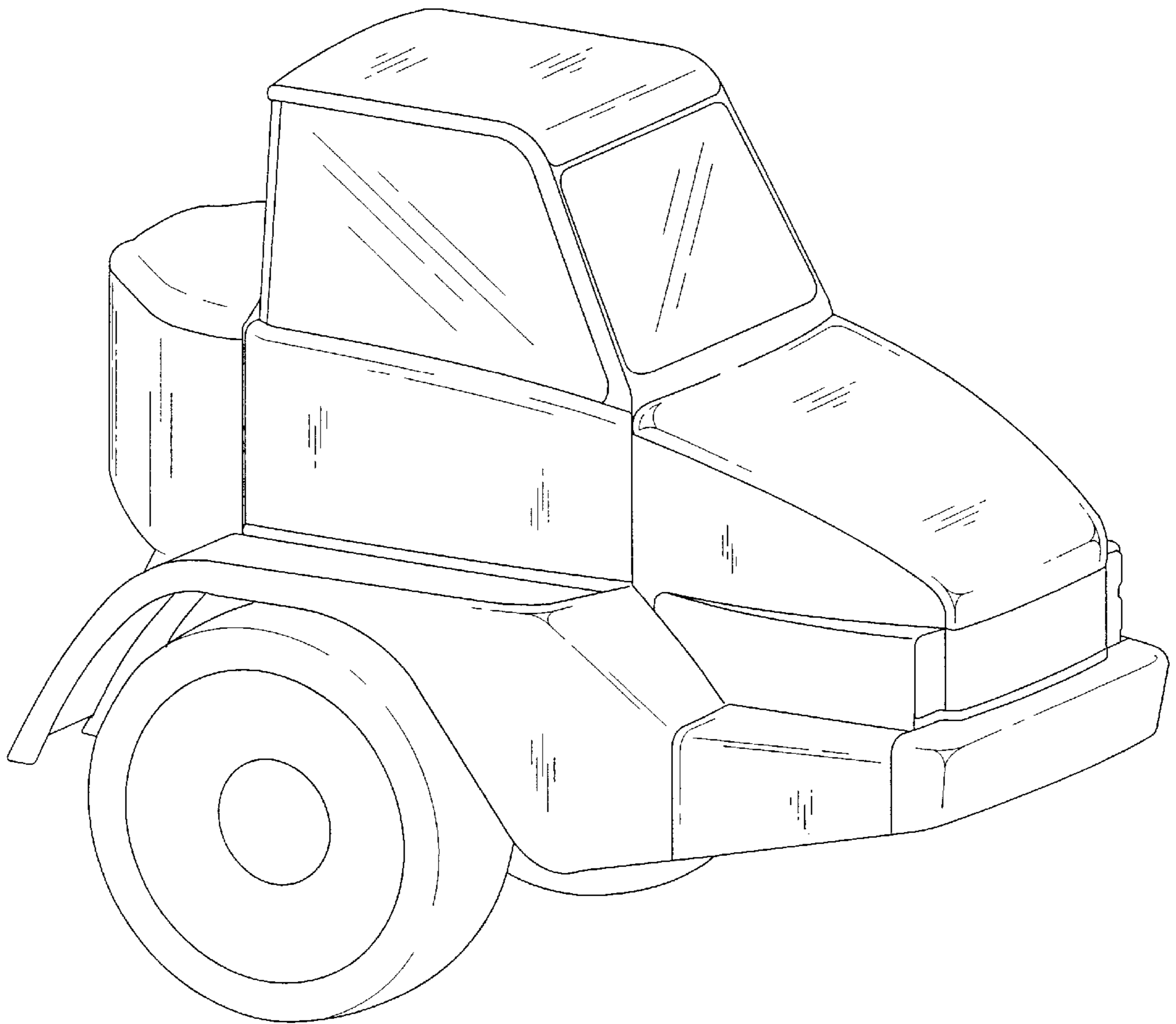

FIG. 9

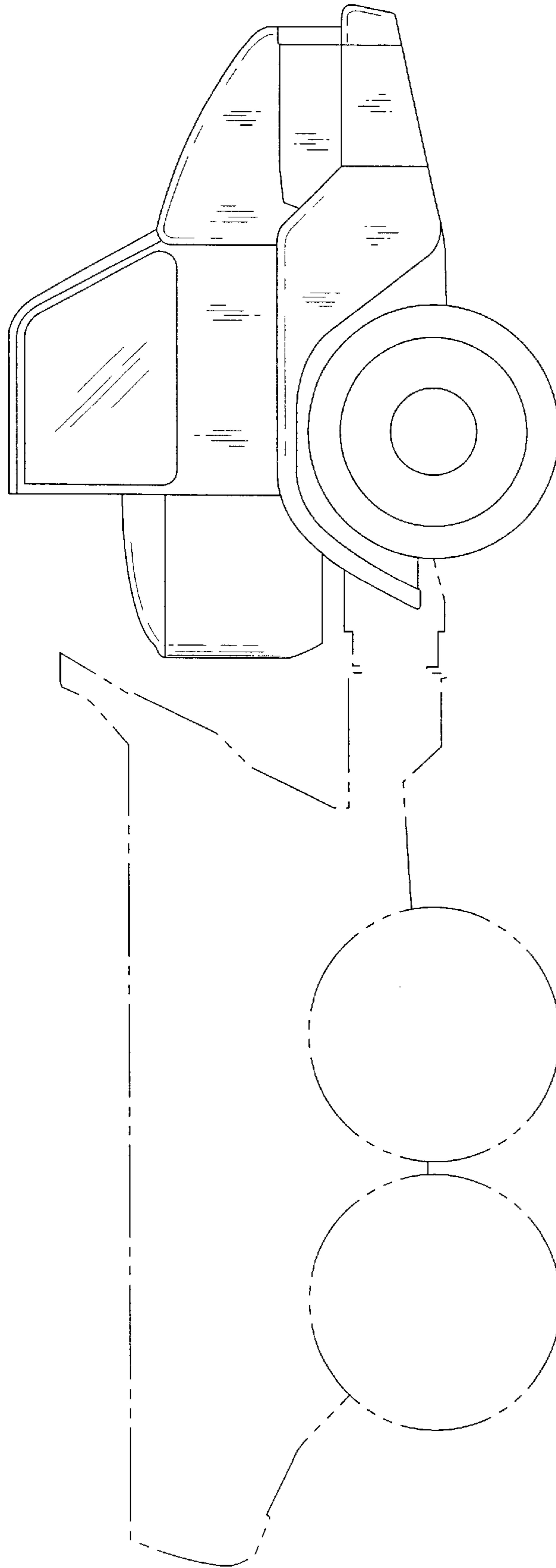

FIG. 10.

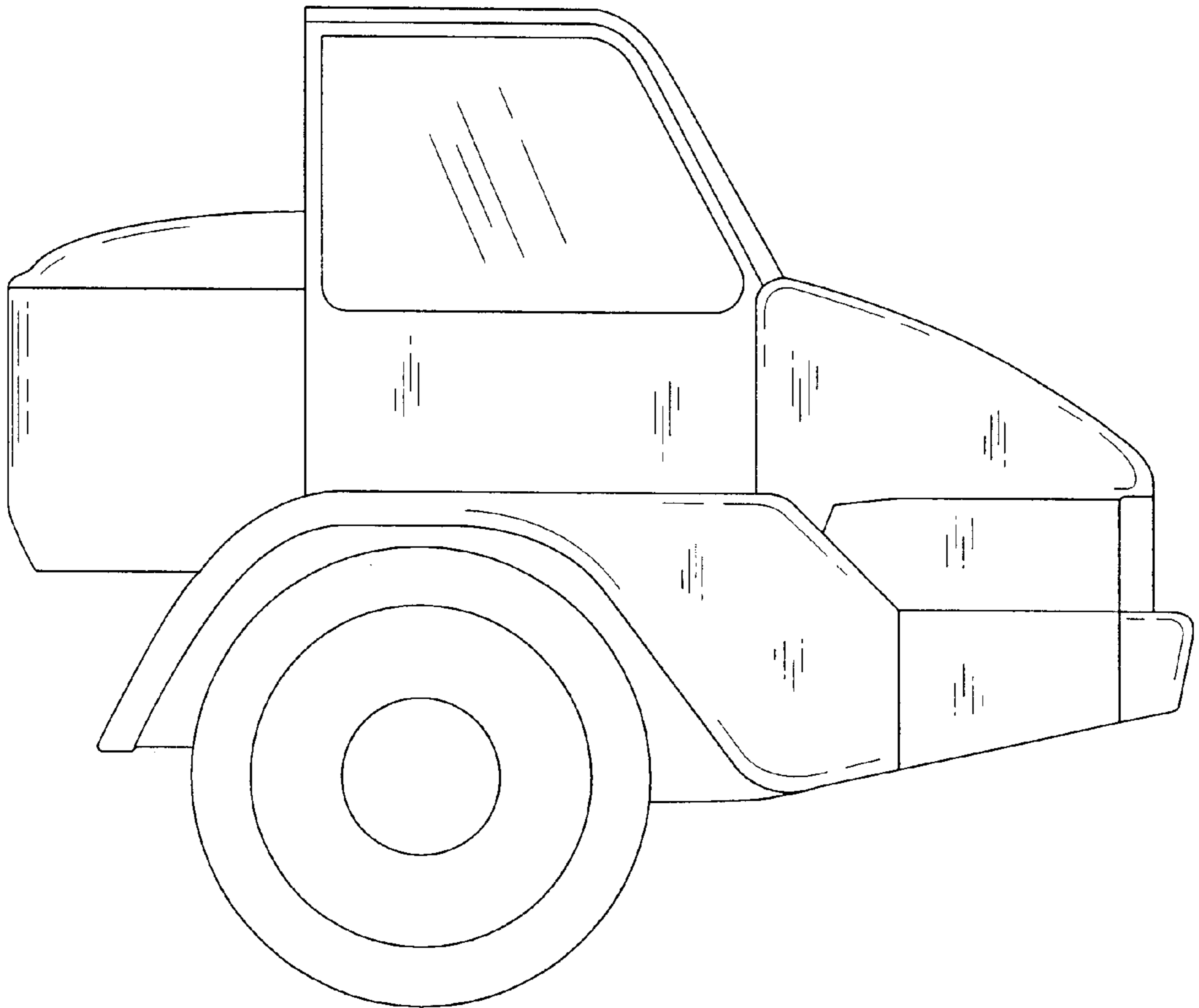

FIG. 11

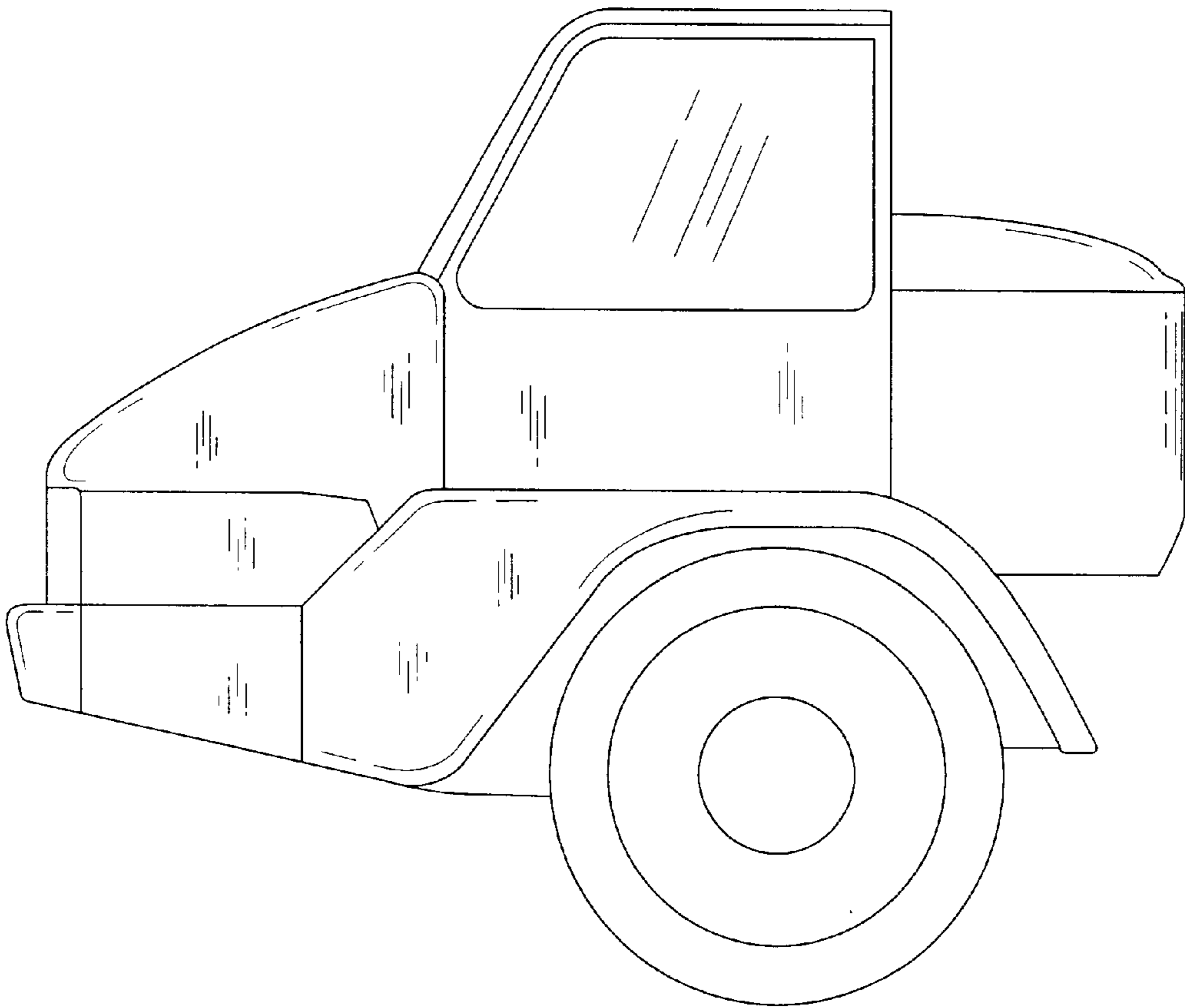

FIG. 12.

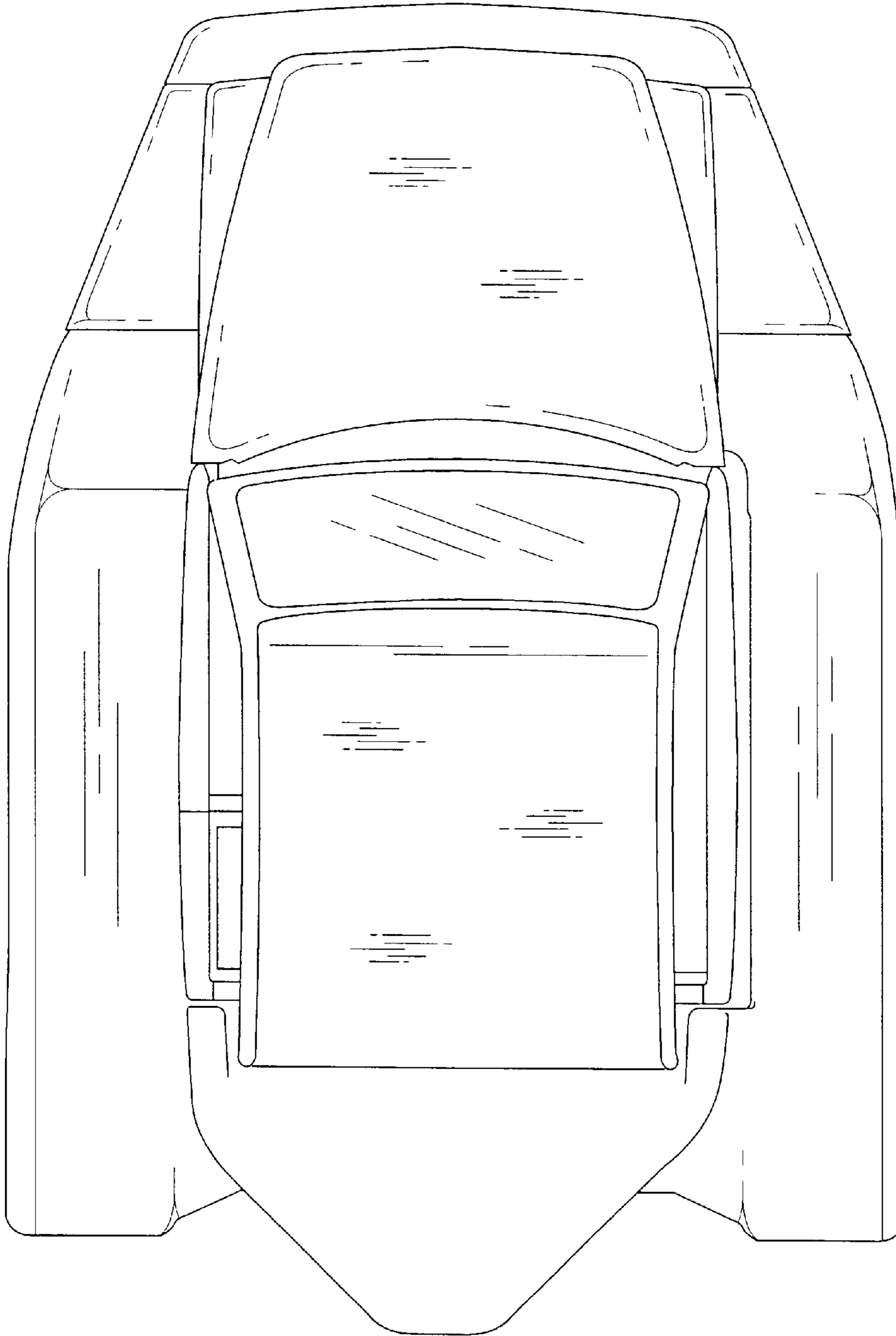

FIG. 13.

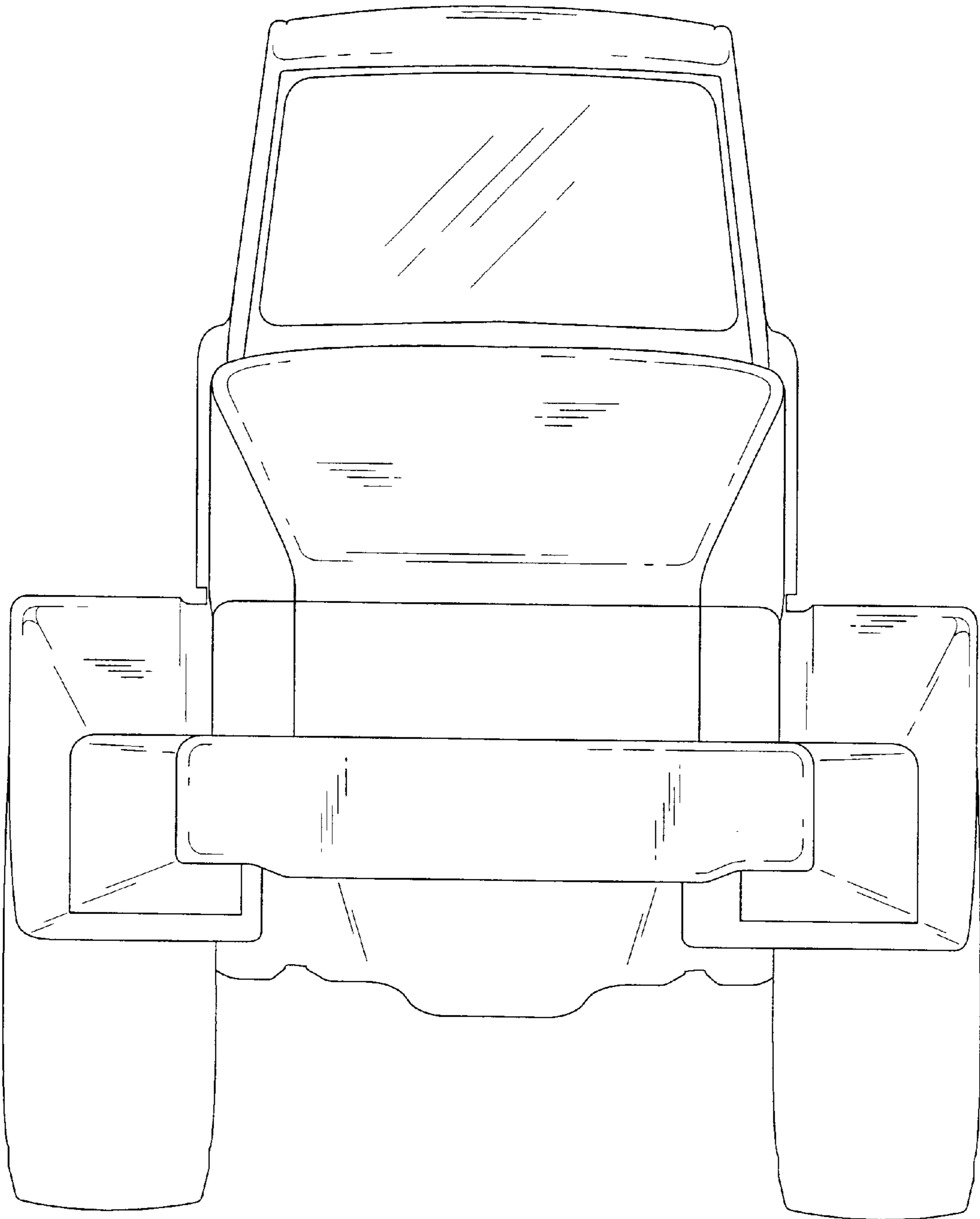

FIG. 14.

