



US00D458873S

(12) **United States Design Patent**  
**Choi et al.**

(10) **Patent No.:** **US D458,873 S**  
(45) **Date of Patent:** **\*\* Jun. 18, 2002**

(54) **AUTOMOBILE**

(75) Inventors: **Young Choi**, Redondo Beach; **Michael P. May**, Rolling Hills Estates, both of CA (US)

(73) Assignee: **Honda Giken Kogyo Kabushiki Kaisha**, Tokyo (JP)

(\*\*) Term: **14 Years**

(21) Appl. No.: **29/145,683**

(22) Filed: **Jul. 30, 2001**

(51) **LOC (7) Cl.** ..... **12-08**

(52) **U.S. Cl.** ..... **D12/92**

(58) **Field of Search** ..... D12/90-92; 296/185

(56) **References Cited**

**U.S. PATENT DOCUMENTS**

- D437,257 S \* 2/2001 Hsu et al. .... D12/92
- D438,492 S \* 3/2001 Nishihata et al. .... D12/92
- D440,186 S \* 4/2001 Herner et al. .... D12/92
- D447,984 S \* 9/2001 Uchino et al. .... D12/492

\* cited by examiner

*Primary Examiner*—Melody N. Brown

(74) *Attorney, Agent, or Firm*—Birch, Stewart, Kolasch & Birch, LLP

(57) **CLAIM**

The ornamental design of an automobile, as shown and described.

**DESCRIPTION**

FIG. 1 is a front, right perspective view of the automobile showing a first embodiment of our new design;

FIG. 2 is a right side, elevational view of the automobile of FIG. 1, the left side being a mirror image of the solid line portions thereof;

FIG. 3 is a rear elevational view of the automobile of FIG. 1;

FIG. 4 is a front elevational view of the automobile of FIG. 1;

FIG. 5 is a top plan view of the automobile of FIG. 1;

FIG. 6 is a rear, right perspective view of the automobile of FIG. 1;

FIG. 7 is a front, right perspective view of a second embodiment of the automobile showing our new design;

FIG. 8 is a right side, elevational view of the automobile of FIG. 7, the left side being a mirror image of the solid line portions thereof;

FIG. 9 is a front elevational view of the automobile of FIG. 7;

FIG. 10 is a top plan view of the automobile of FIG. 7;

FIG. 11 is a front, right perspective view of a third embodiment of the automobile showing our new design;

FIG. 12 is a right side, elevational view of the automobile of FIG. 11, the left side being a mirror image of the solid line portions thereof;

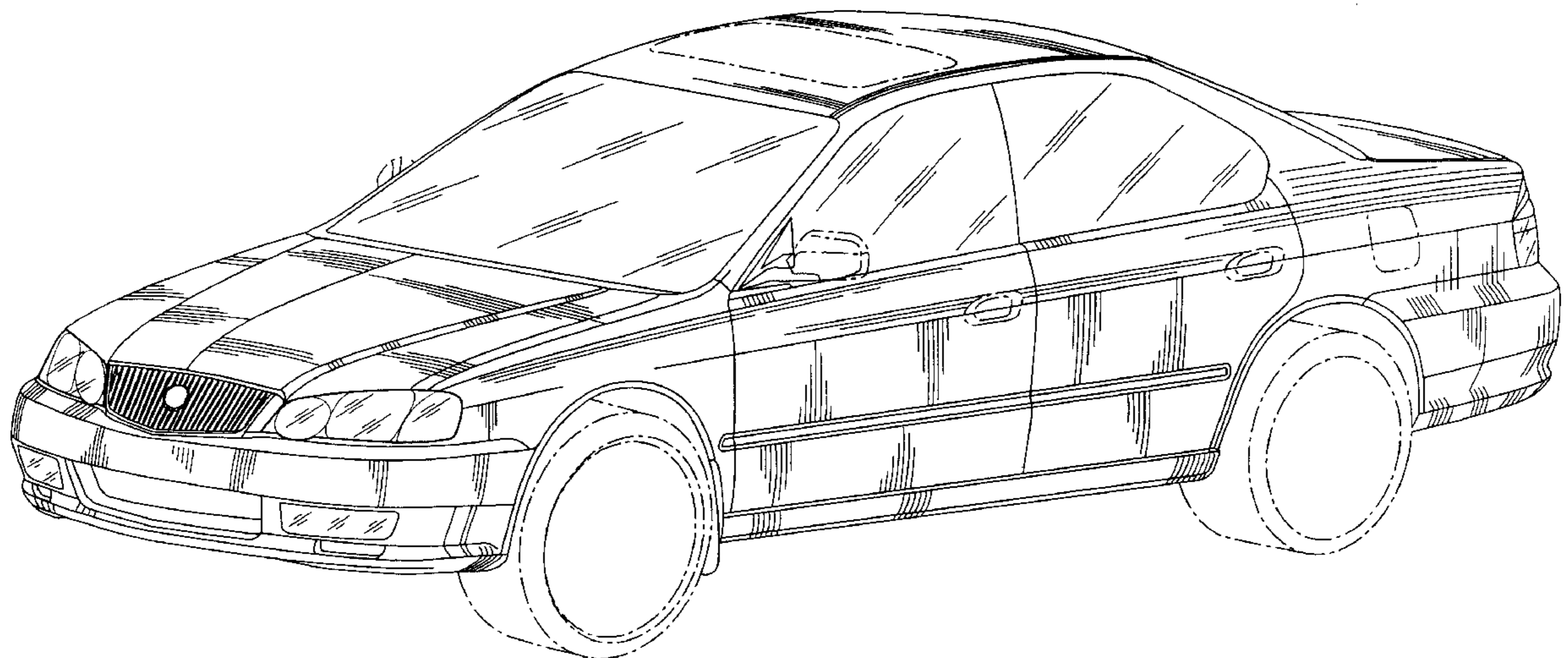
FIG. 13 is a front elevational view of the automobile of FIG. 11; and,

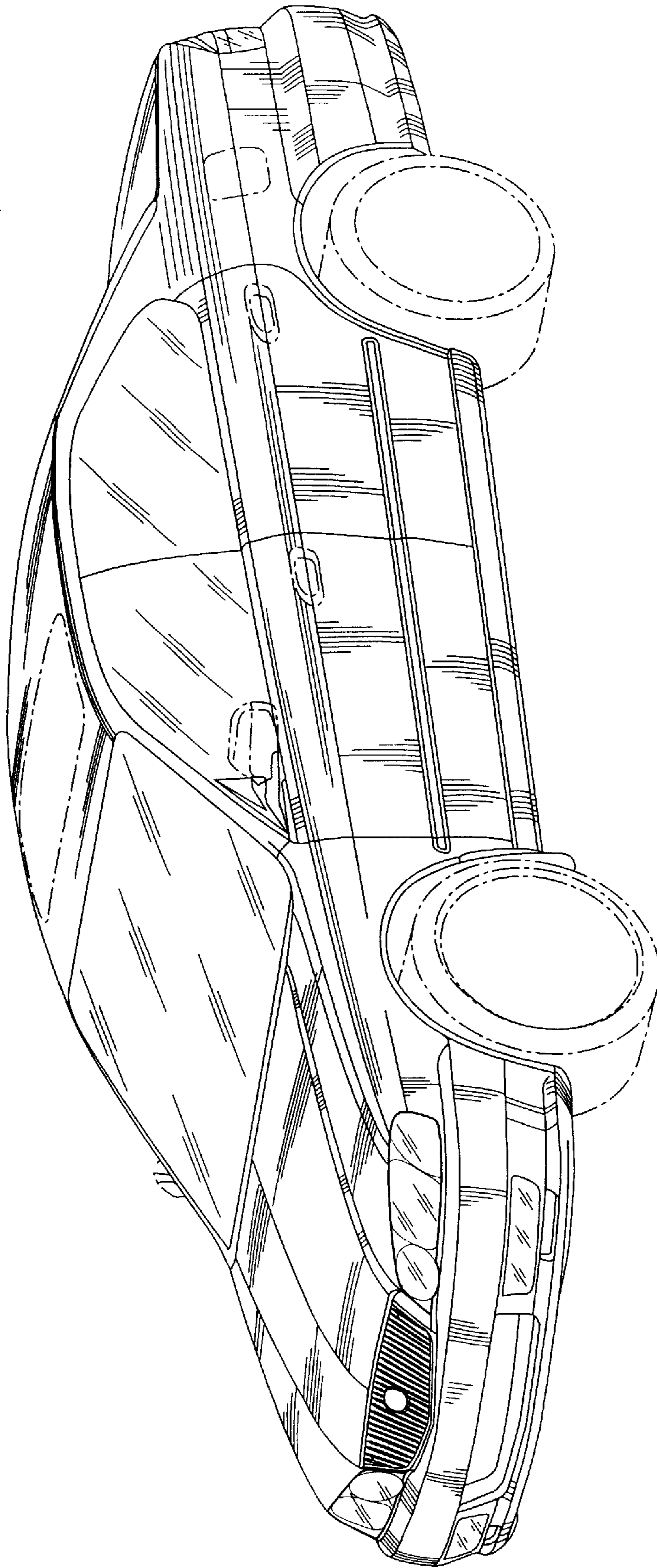
FIG. 14 is a top plan view of the automobile of FIG. 11.

The portions shown in broken lines are for environmental purposes only and form no part of the claimed design.

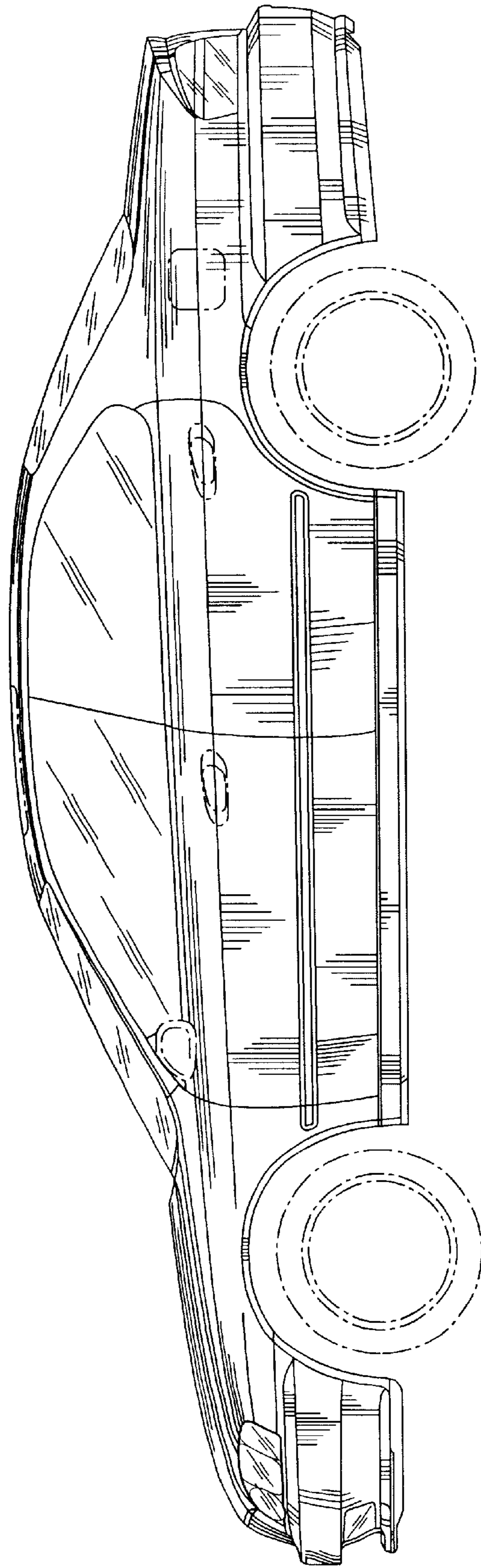
The rear elevational view and the rear, right perspective view for the second embodiment of FIG. 7 are the same as for the first embodiment of FIG. 1. Also, the rear elevational view and the rear, right perspective view for the third embodiment of FIG. 11 are the same as for the first embodiment of FIG. 1.

**1 Claim, 13 Drawing Sheets**



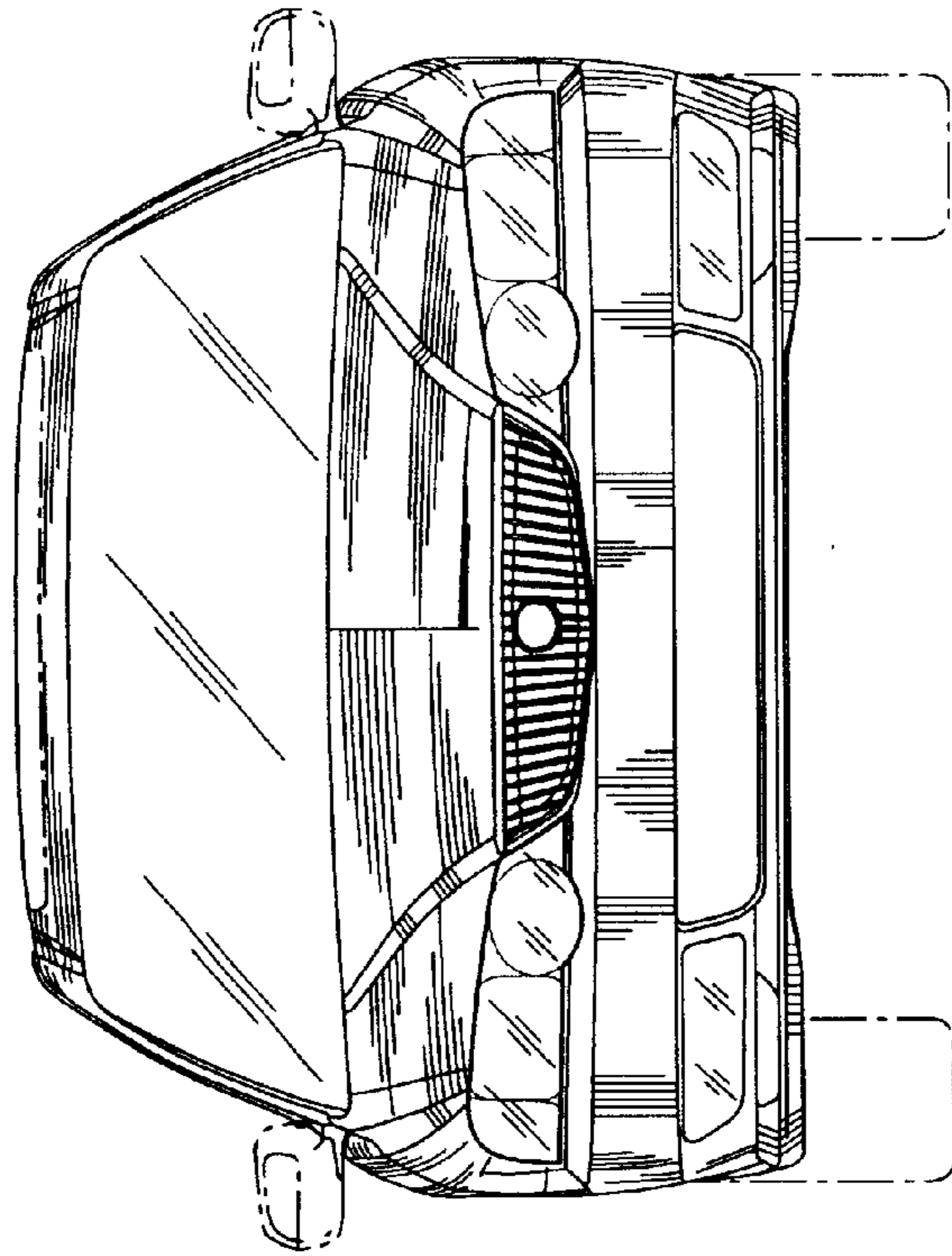


**FIG. 1**

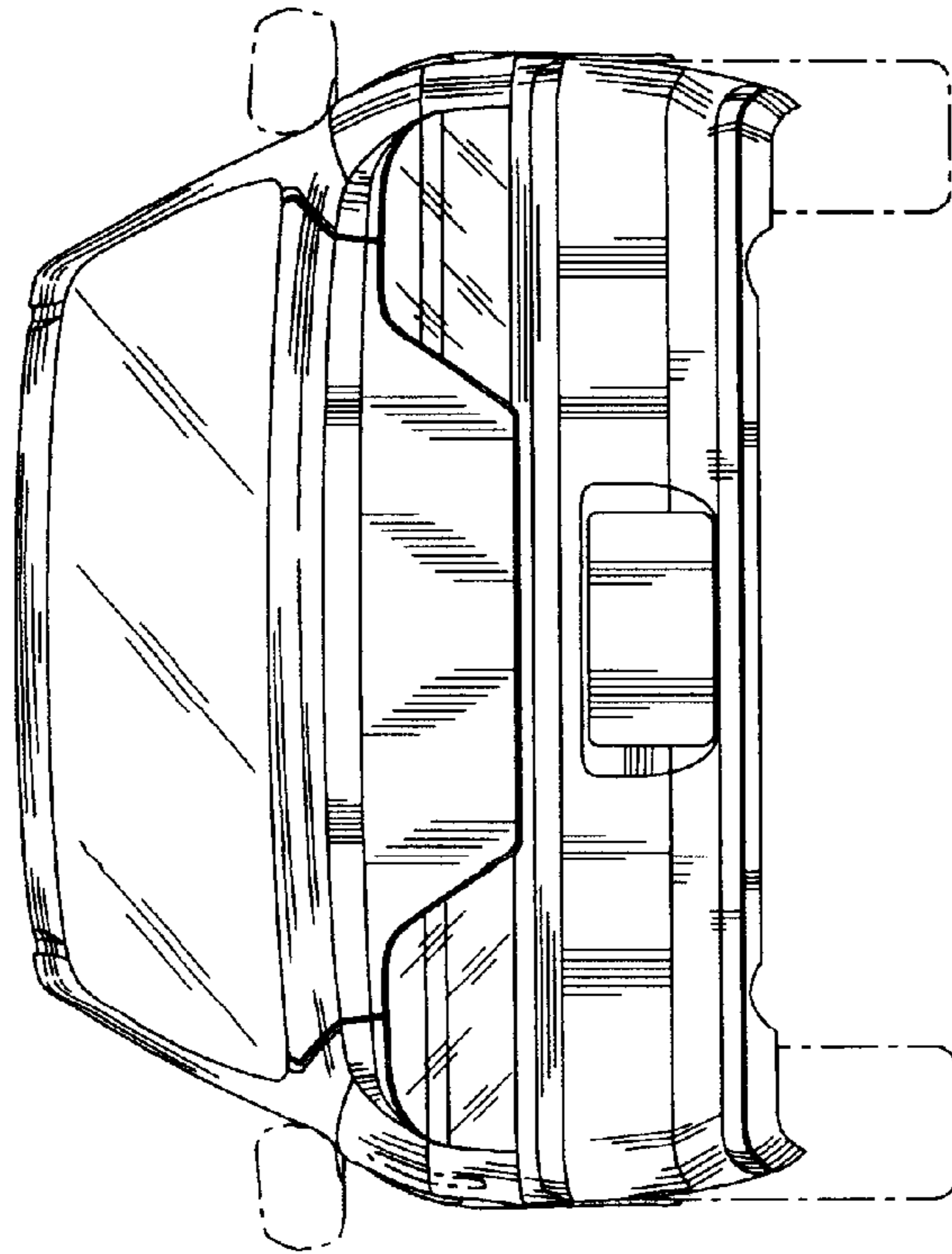


**FIG. 2**

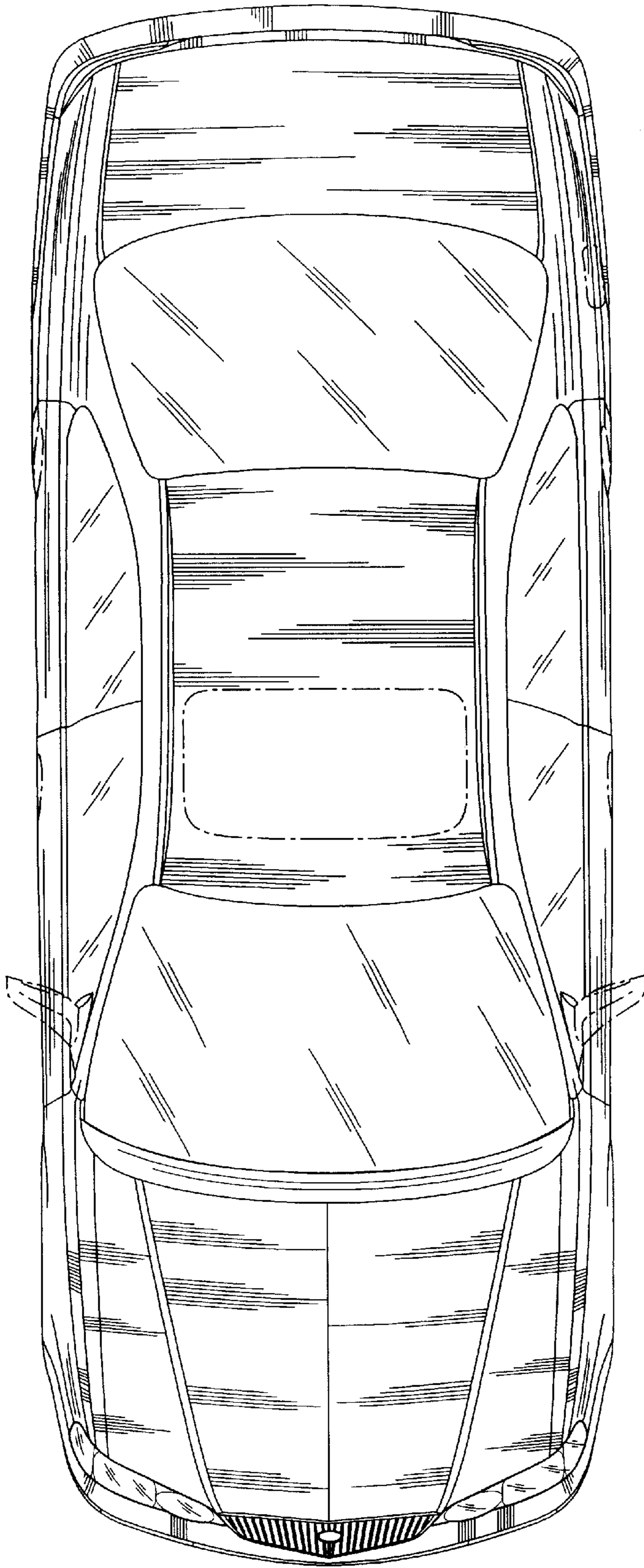




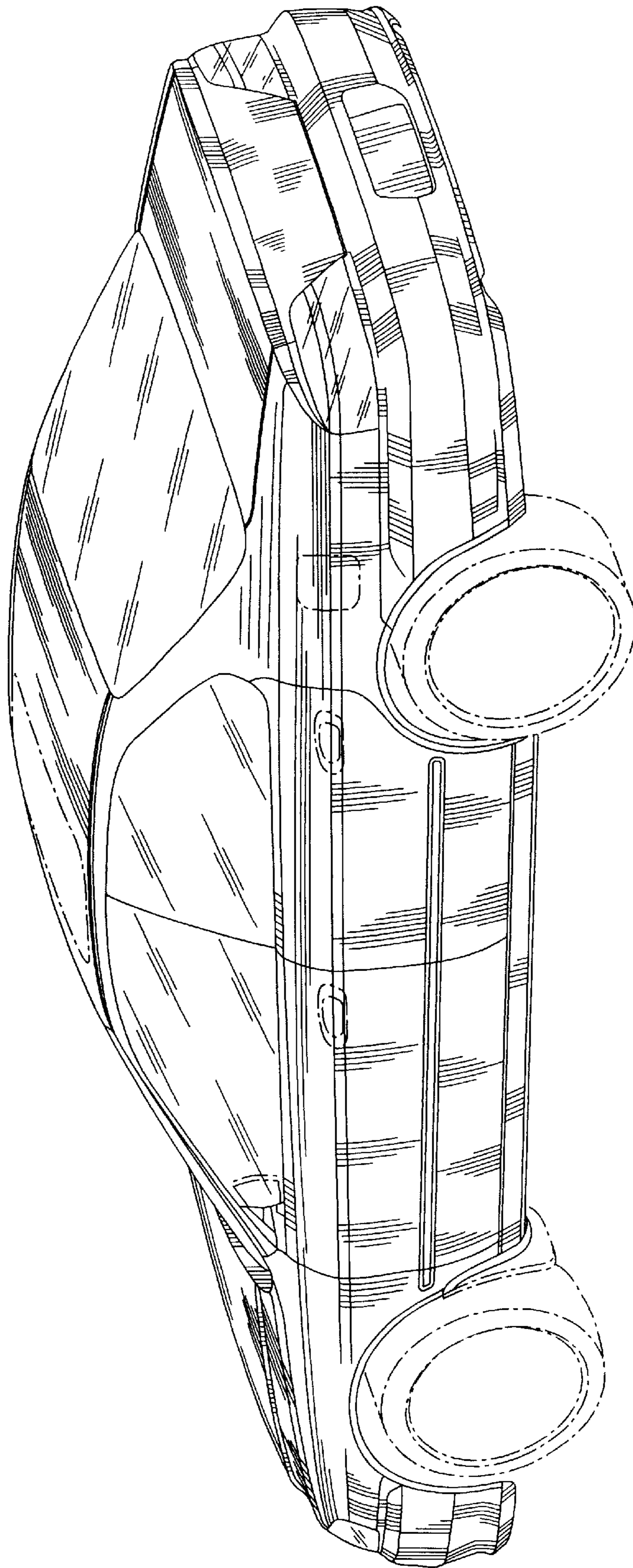
**FIG. 3**



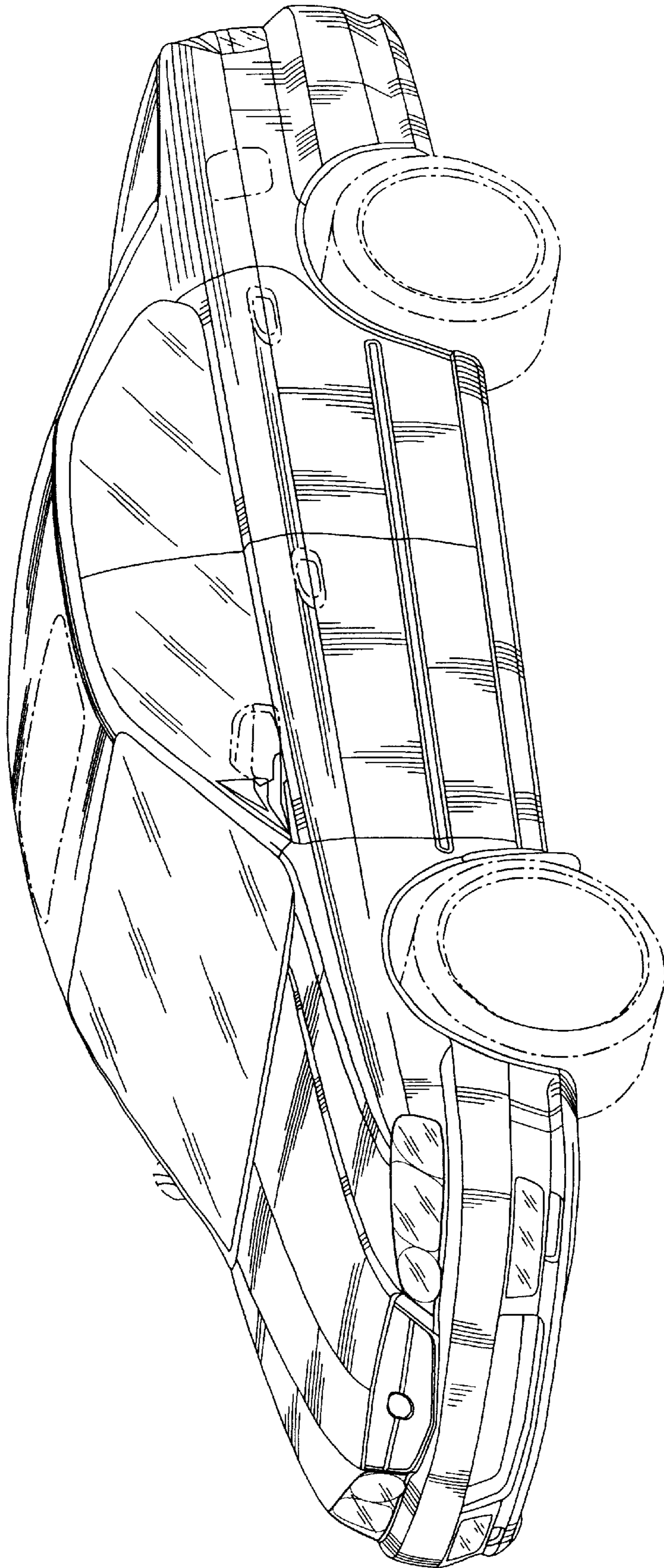
**FIG. 4**



**FIG. 5**

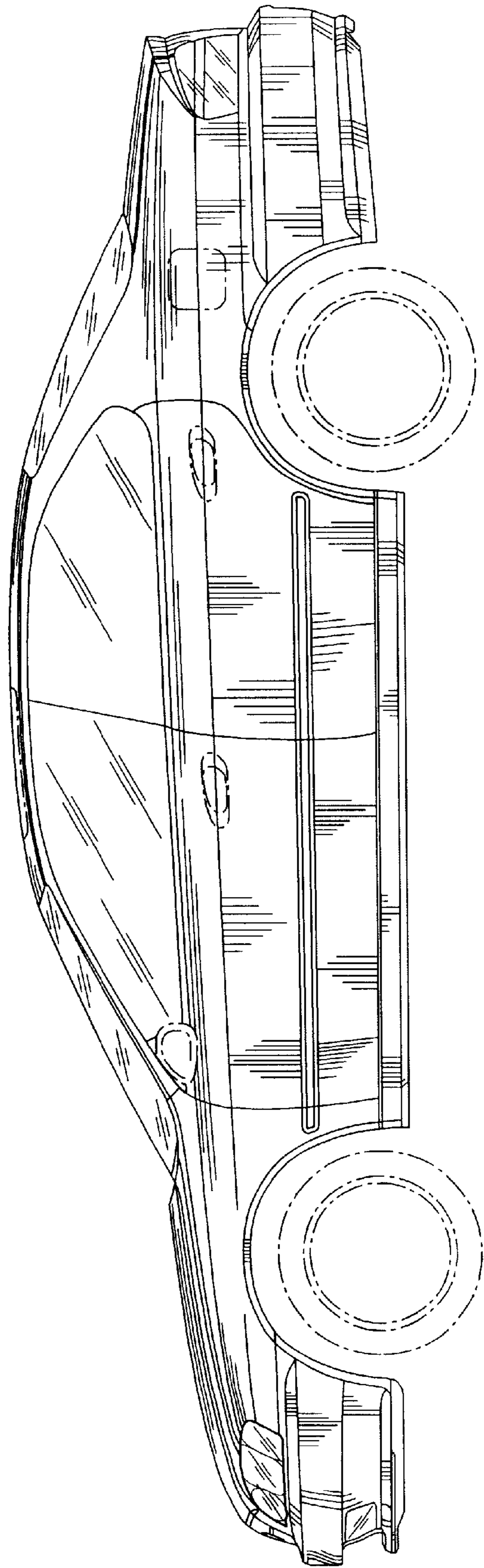


**FIG. 6**



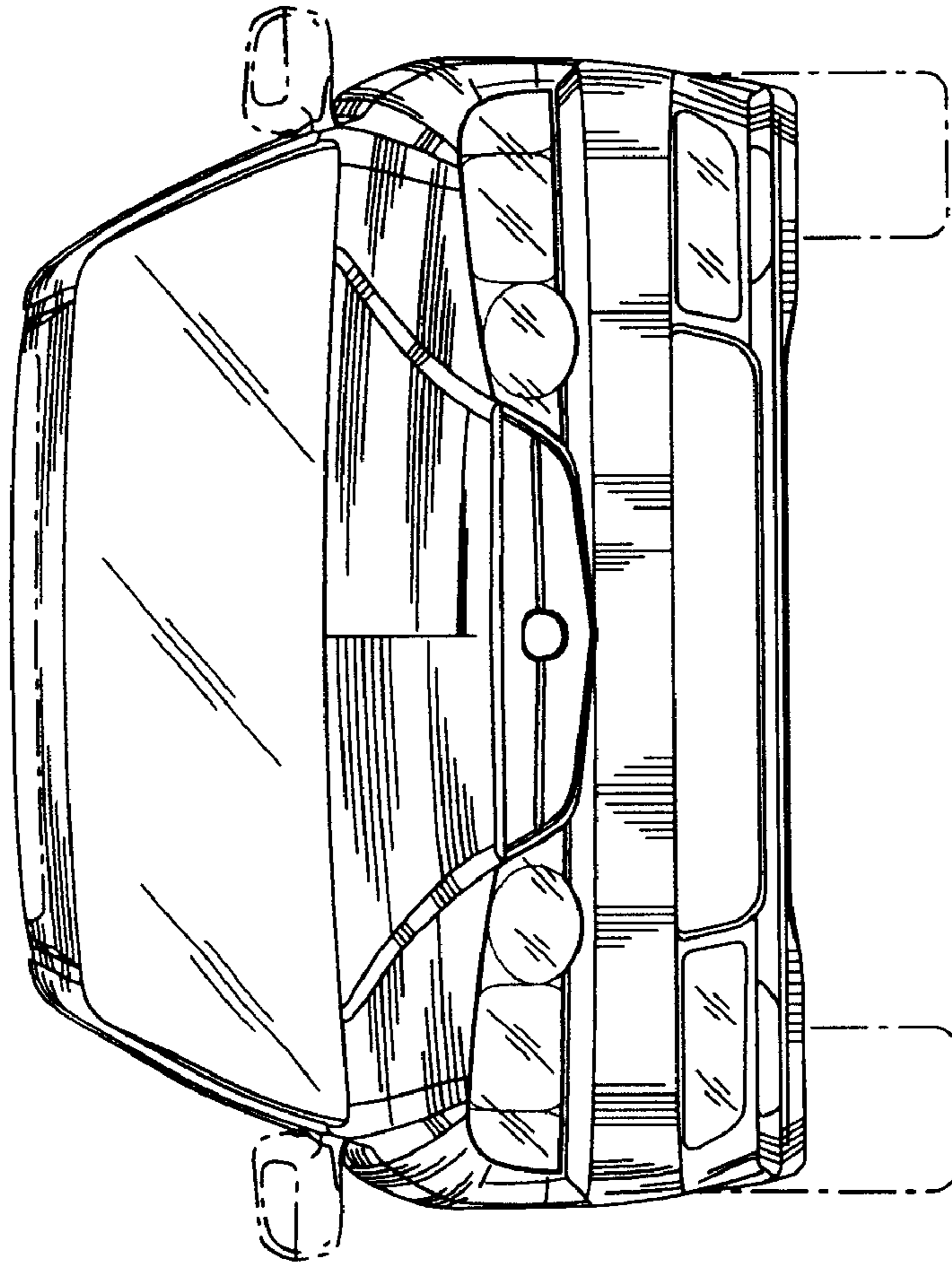
**FIG. 7**



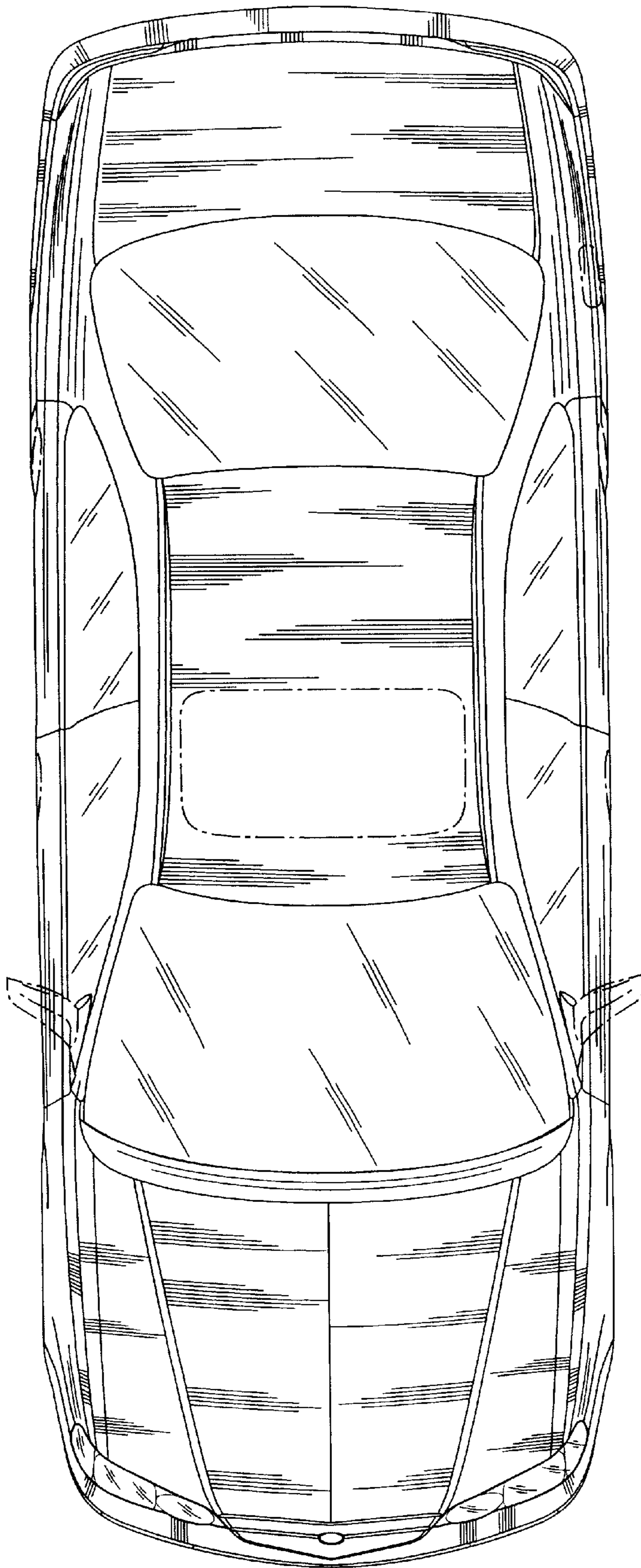


**FIG. 8**

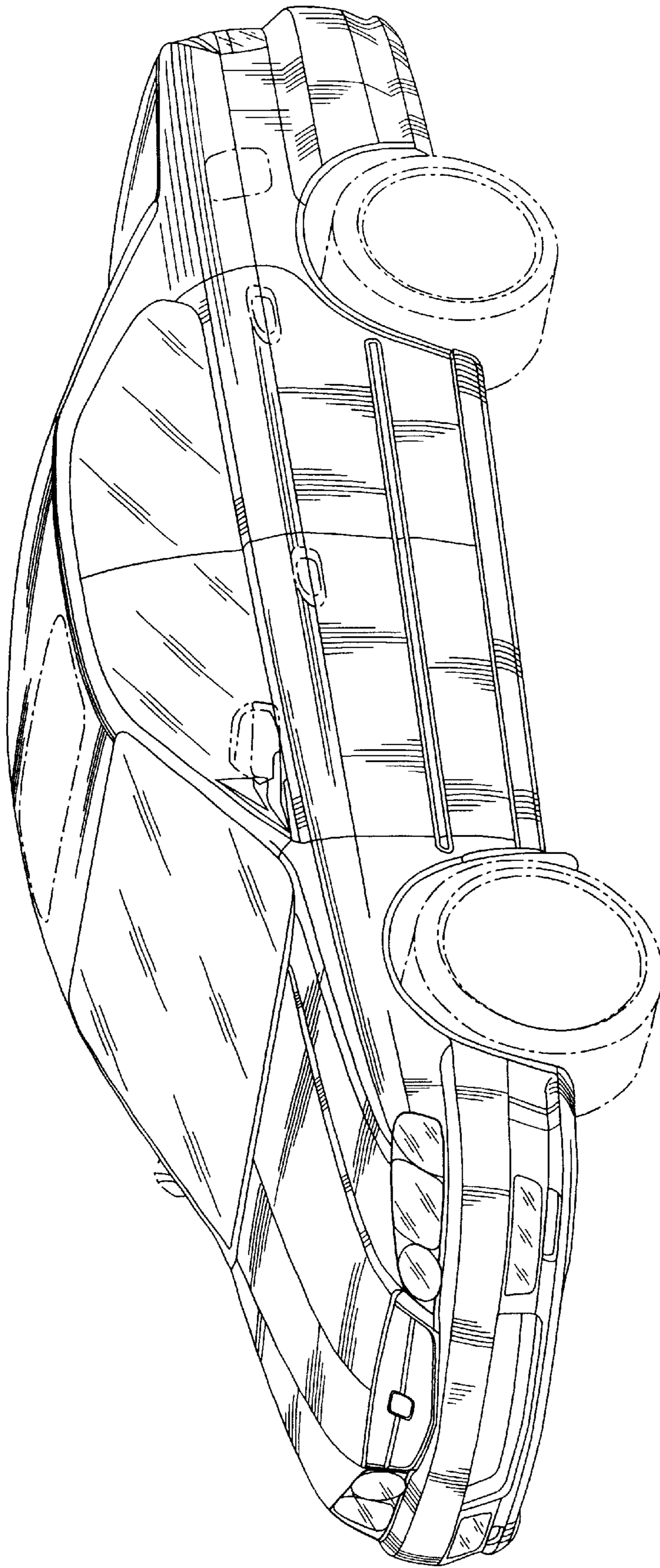




**FIG. 9**

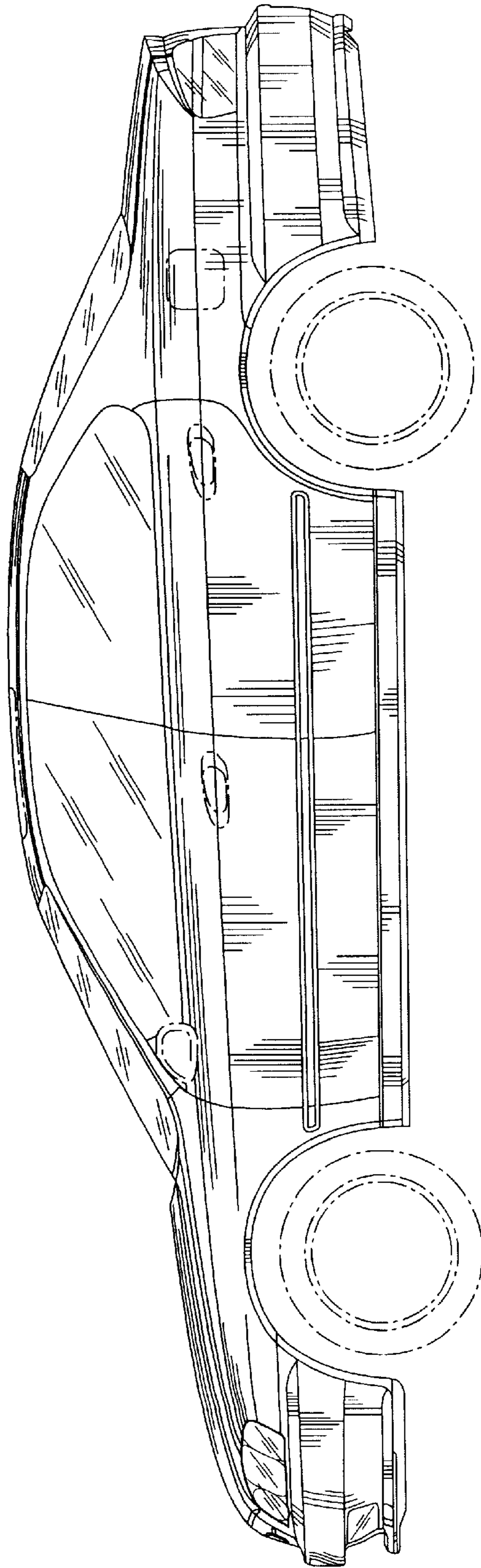


**FIG. 10**

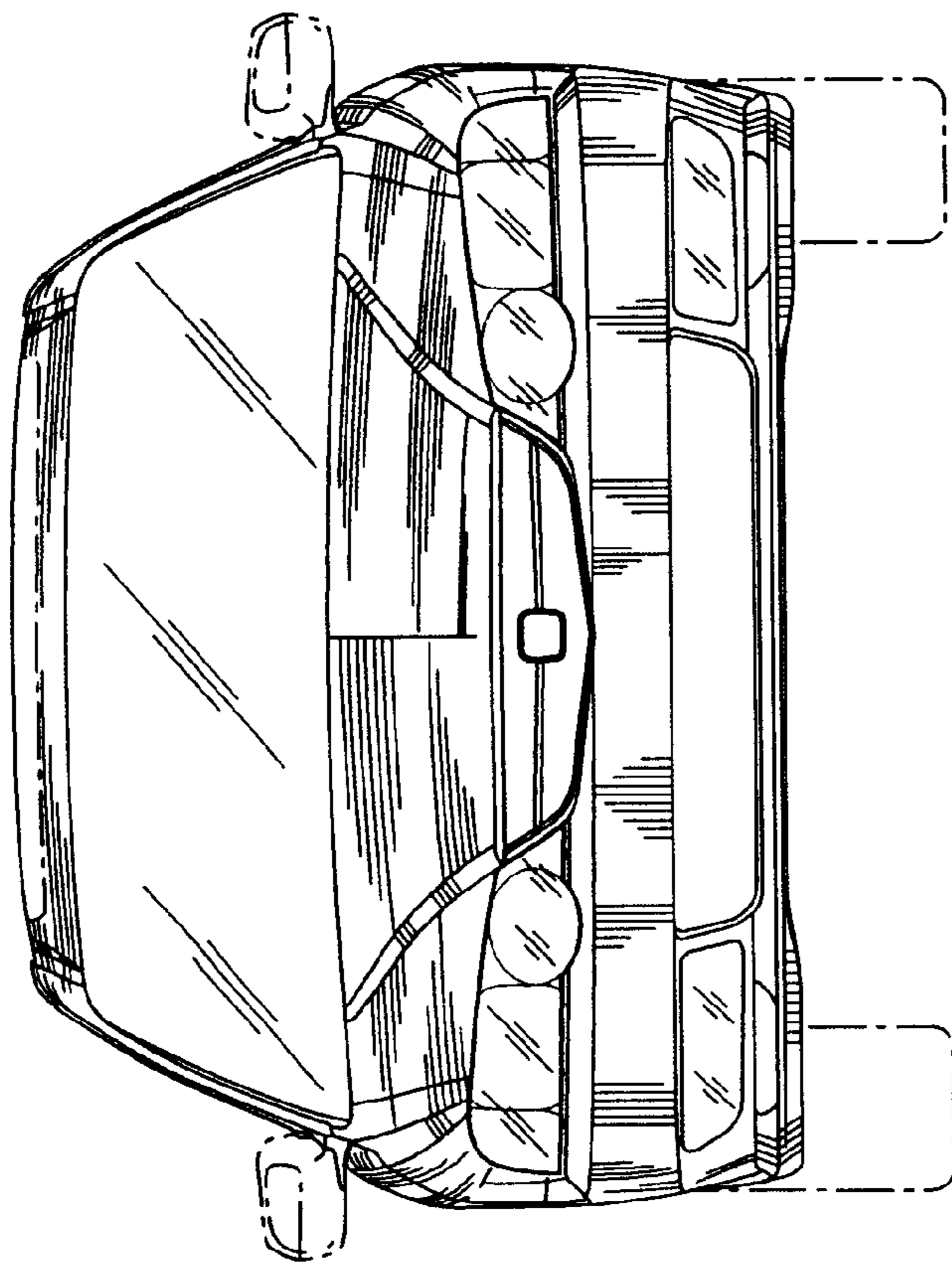


**FIG. 11**

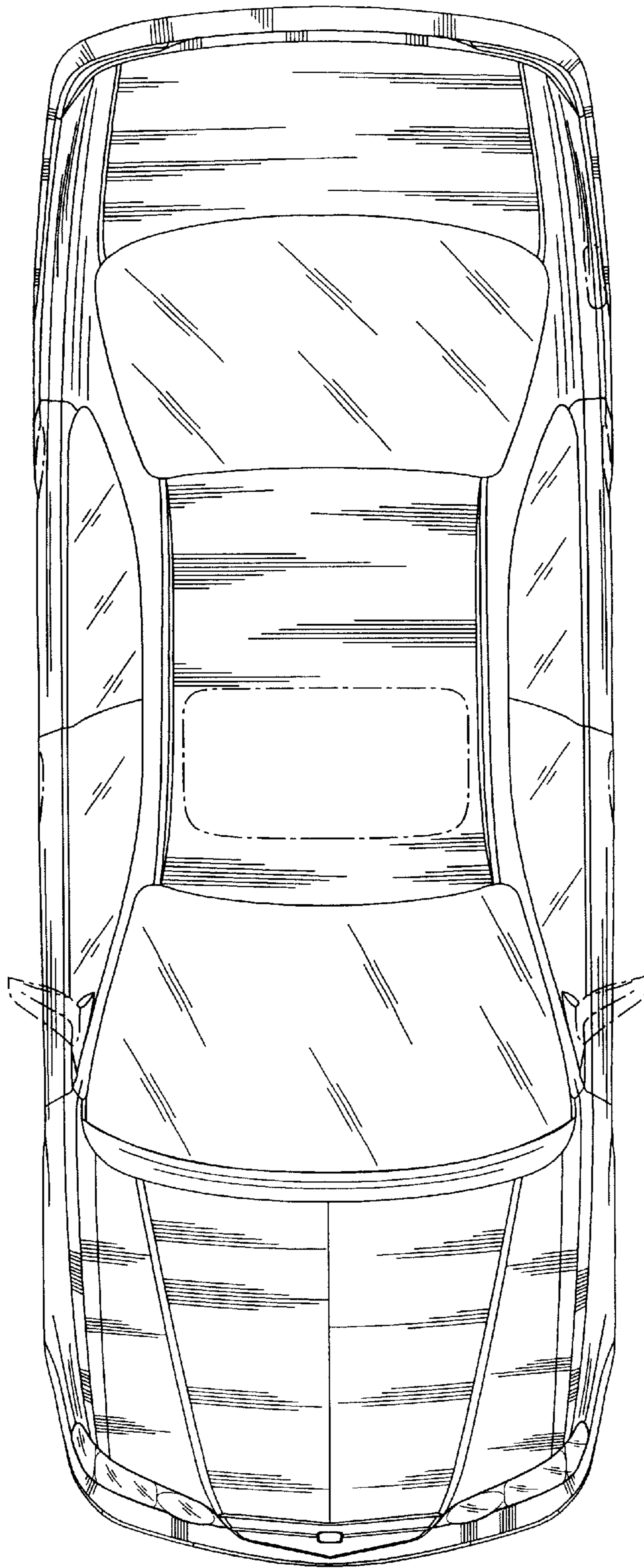




**FIG. 12**



**FIG. 13**



**FIG. 14**