



US00D458578S

(12) **United States Design Patent**
Hrysko

(10) **Patent No.:** **US D458,578 S**

(45) **Date of Patent:** **** Jun. 11, 2002**

(54) **CAR DOOR RESTRAINING DEVICE**

(76) Inventor: **Paul Hrysko**, 122 Hatton Drive,
Ancaster, Ontario (CA), L9G 2H6

(**) Term: **14 Years**

(21) Appl. No.: **29/140,136**

(22) Filed: **Apr. 13, 2001**

(51) **LOC (7) Cl.** **12-16**

(52) **U.S. Cl.** **D12/400; D8/339**

(58) **Field of Search** **D12/400; D8/330-331,**
D8/339, 341; 70/202, 210, 225, 237-238,
240, 91, 95-98

(56) **References Cited**

U.S. PATENT DOCUMENTS

3,245,239	A	*	4/1966	Zaidener	70/202
D228,874	S	*	10/1973	Thomson	D8/339
4,819,461	A	*	4/1989	Pearson	70/202
D346,106	S	*	4/1994	Walls	D8/339
D350,056	S	*	8/1994	Lin	D8/331
D350,472	S	*	9/1994	White et al.	D8/331
D365,269	S	*	12/1995	Valles	D8/331
D368,421	S	*	4/1996	Jensen, Sr.	D8/331
D369,951	S	*	5/1996	Crittenden	D8/331
D398,831	S	*	9/1998	Walton	D8/338
6,058,749	A	*	5/2000	Rekemeyer	70/226

* cited by examiner

Primary Examiner—Stacia Cadmus

(57) **CLAIM**

The ornamental design for a car door restraining device, as shown.

DESCRIPTION

FIG. 1 is a top plan view of a car door restraining device showing a first embodiment of our new design.

FIG. 2 is a partial cut away top plan view of a portion of the car door restraining device circled in FIG. 1 showing the locking mechanism.

FIG. 3 is a side elevational view of the first embodiment of the car door restraining device.

FIG. 4 is a bottom plan view of the car door restraining device.

FIG. 5 is a top perspective view of the car door restraining device shown in FIG. 3.

FIG. 6 is a bottom perspective view of the car door restraining device shown in FIG. 3.

FIG. 7 is a top plan view of a car door restraining device showing a second embodiment of our new design.

FIG. 8 is a partial cut away top plan view of a portion of the car door restraining device circled in FIG. 7 showing the locking mechanism.

FIG. 9 is a side elevational view of the second embodiment of the car door restraining device.

FIG. 10 is a bottom plan view of the car door restraining device, shown in FIG. 9.

FIG. 11 is a top perspective view of the car door restraining device shown in FIG. 9; and,

FIG. 12 is a bottom perspective view of the car door restraining device shown in FIG. 9.

1 Claim, 6 Drawing Sheets

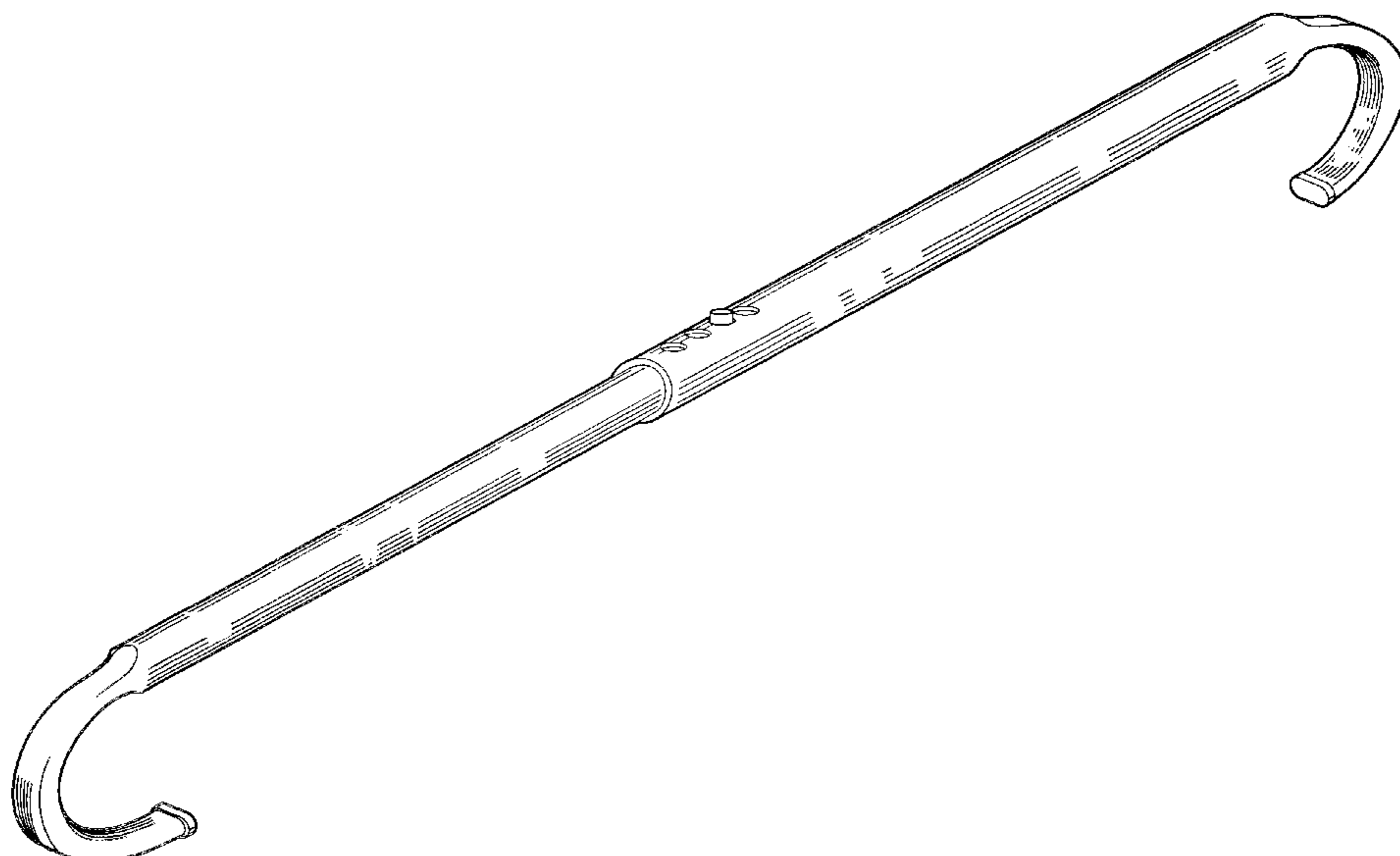

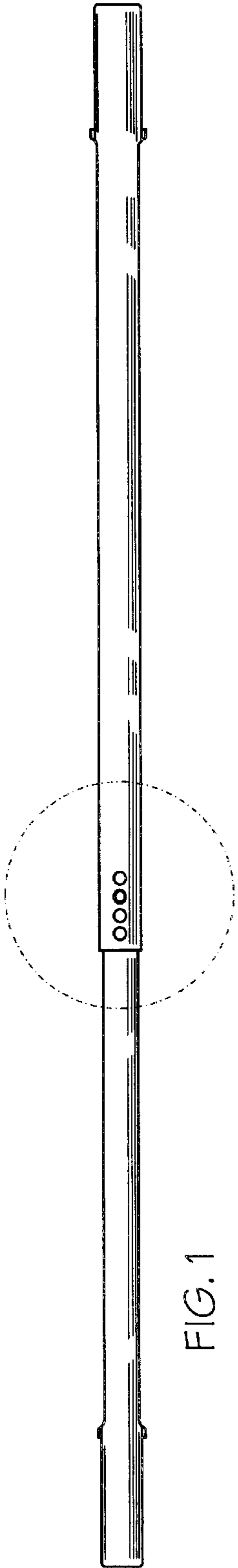

FIG. 1

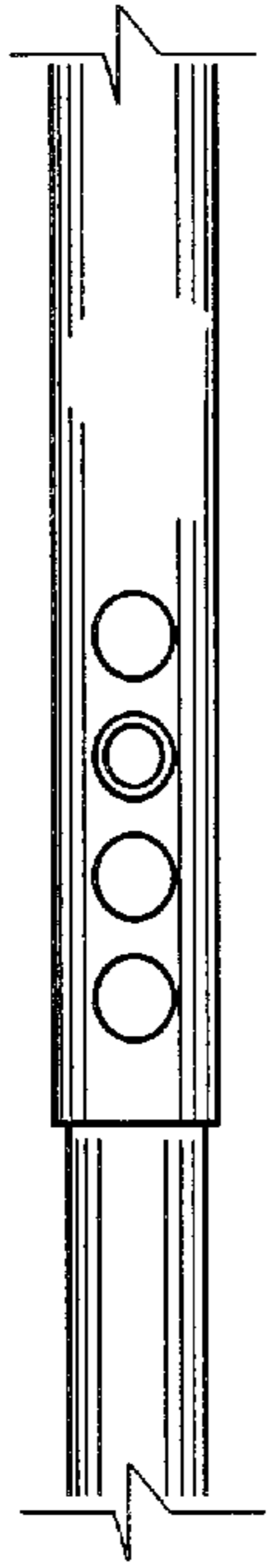

FIG. 2

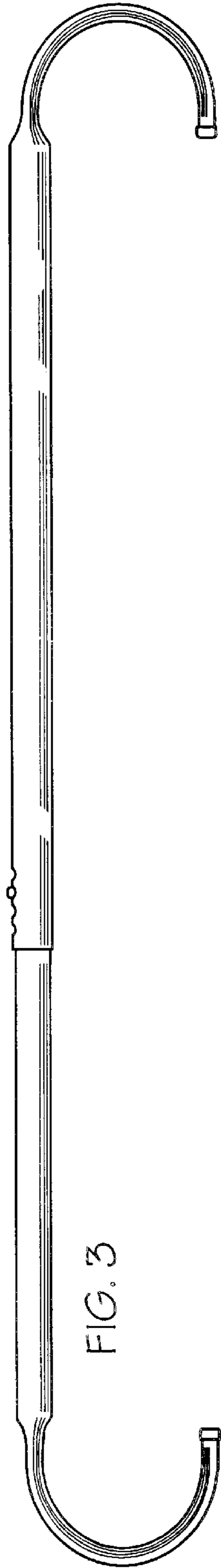

FIG. 3



FIG. 4

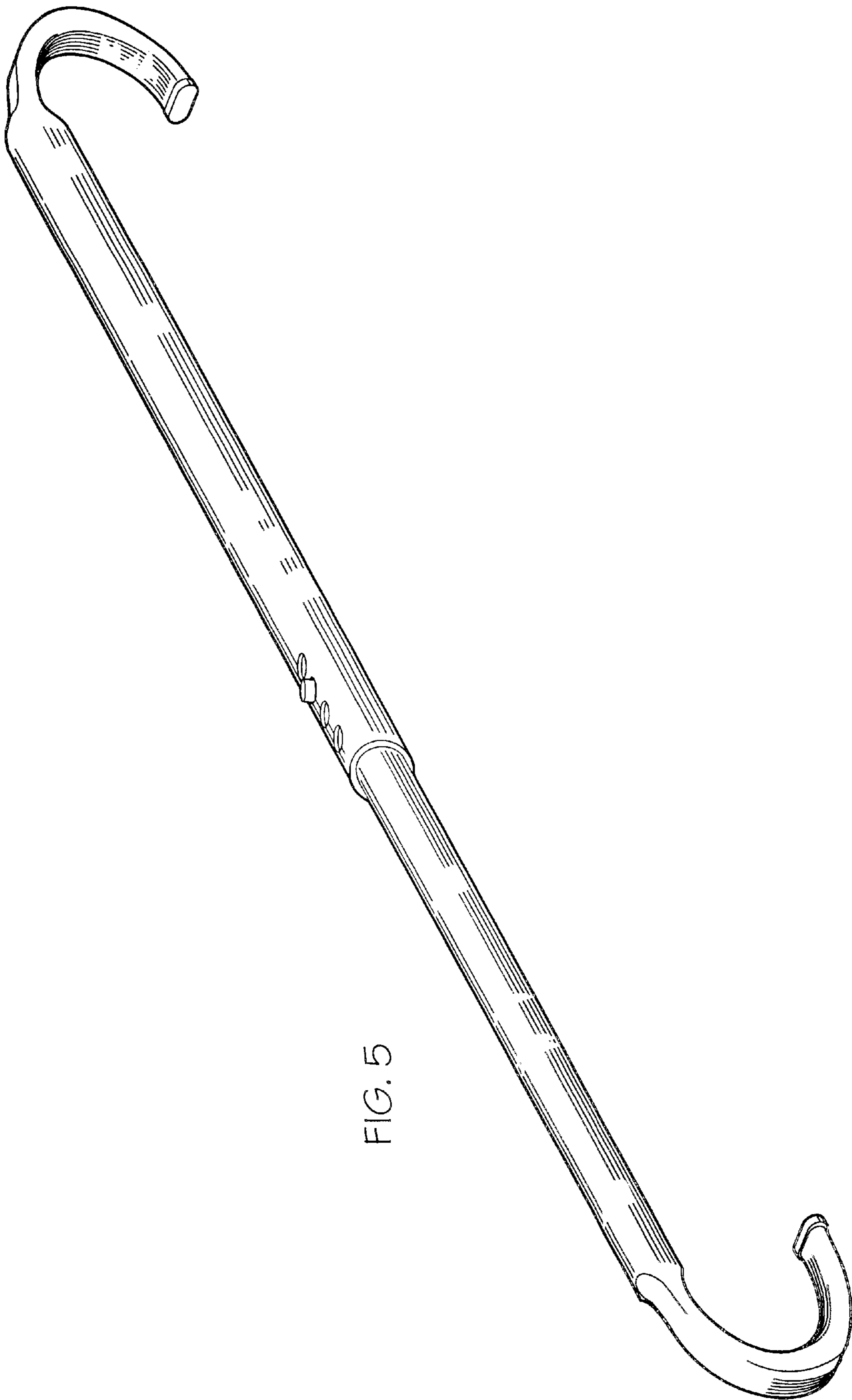

FIG. 5

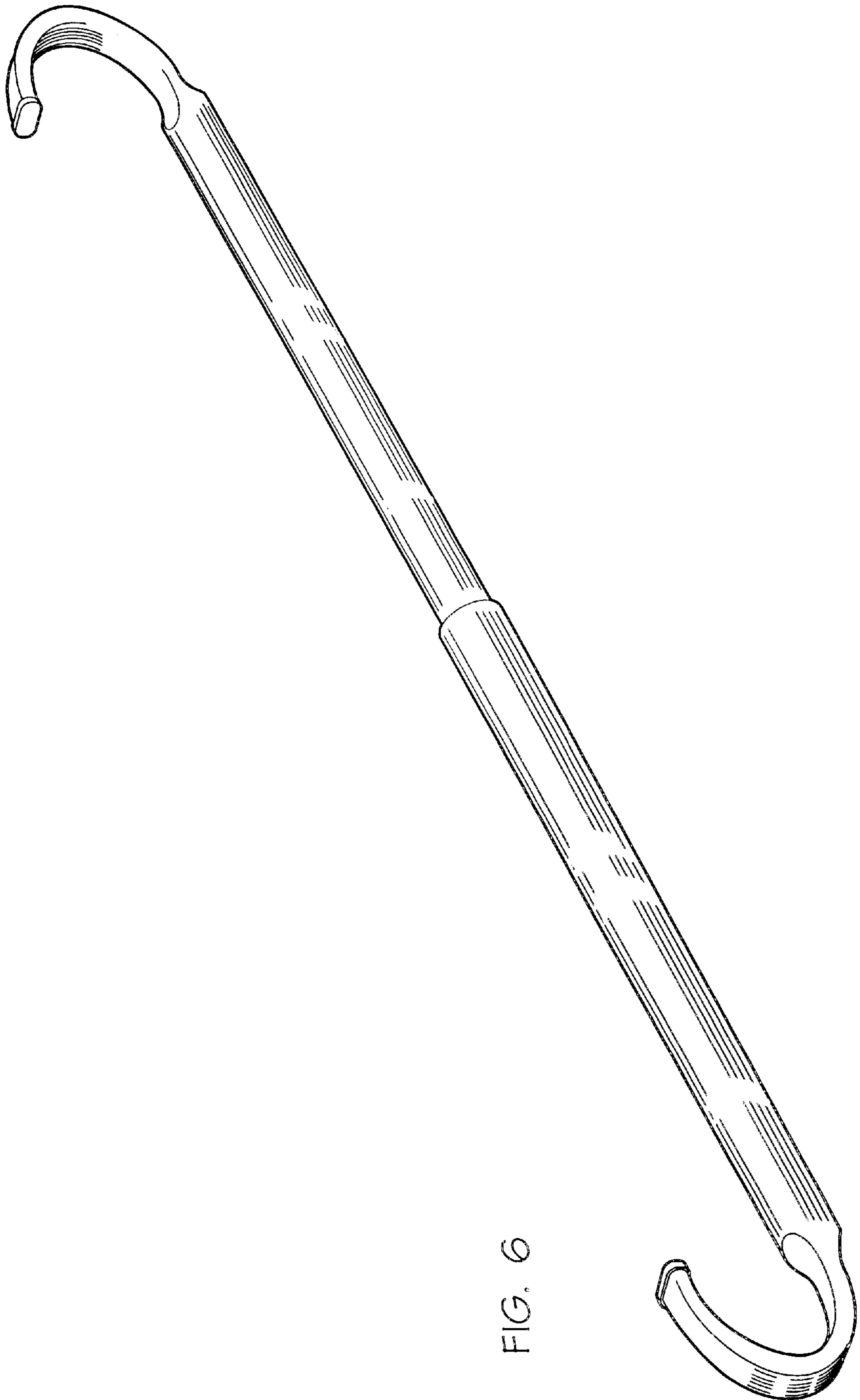

FIG. 6

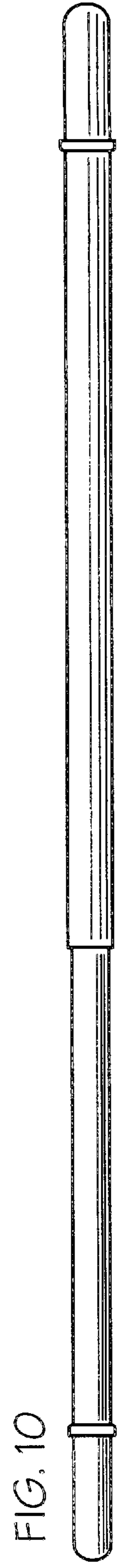
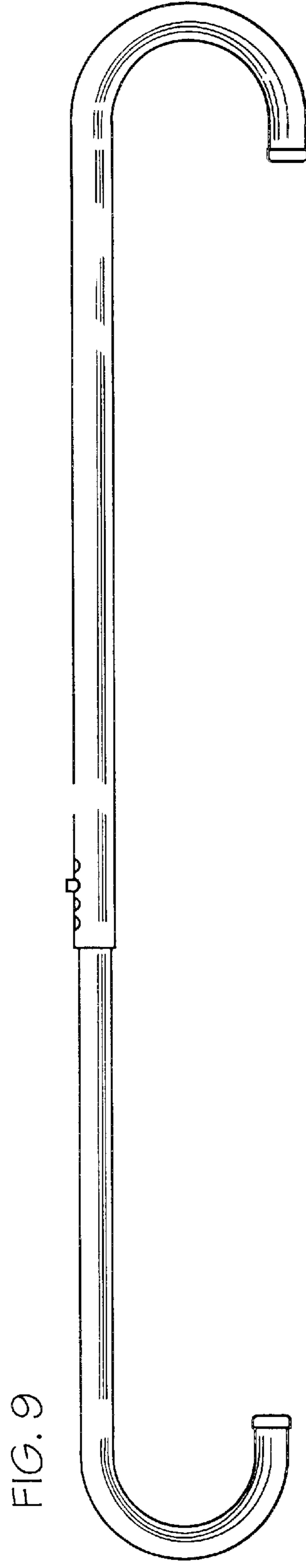
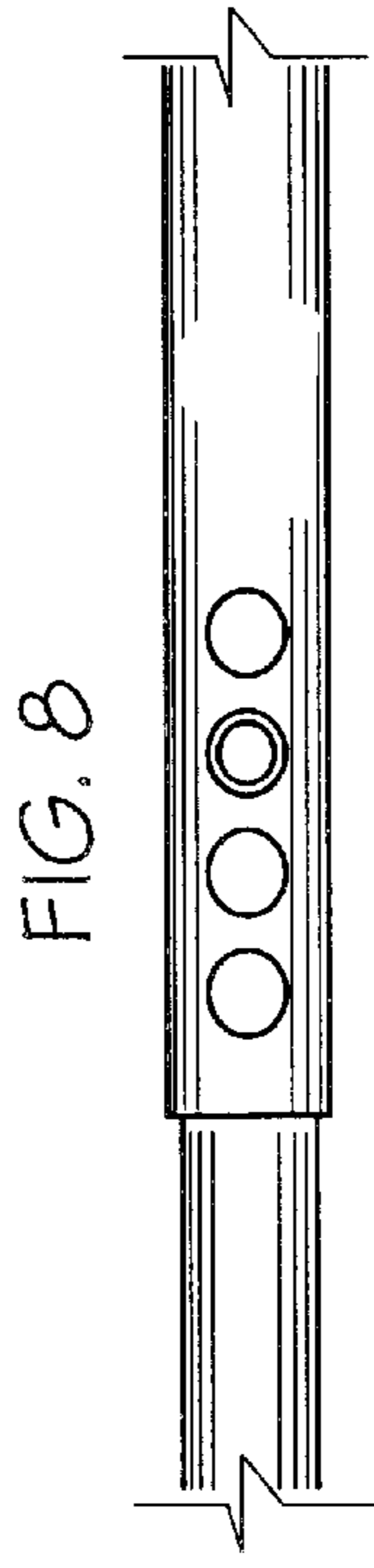
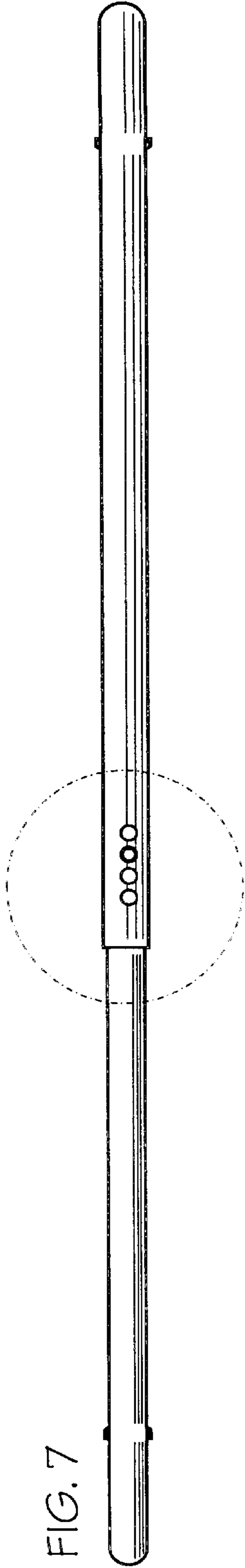



FIG. 11

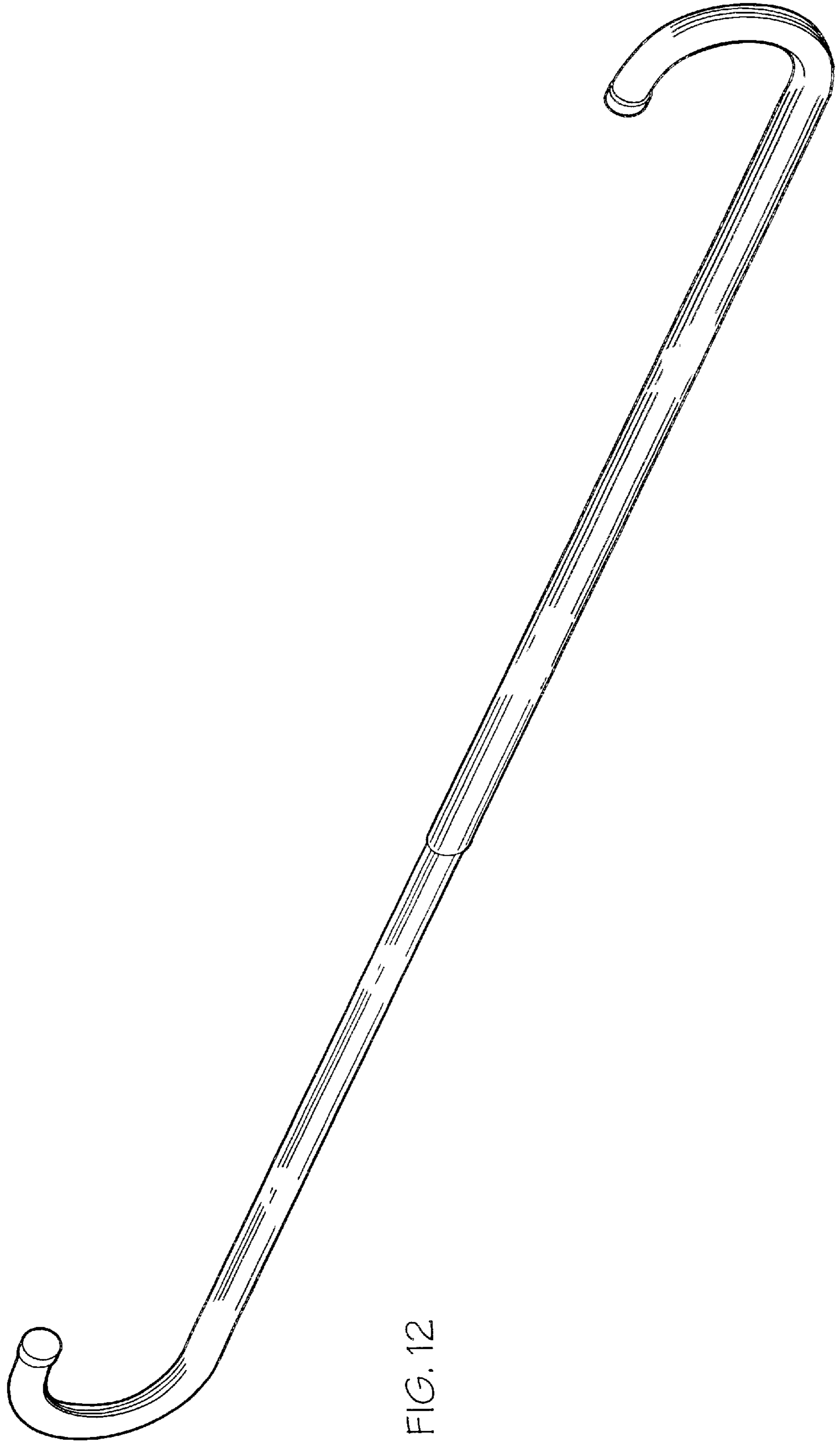

FIG. 12