



US00D458570S

(12) **United States Design Patent**
Wang

(10) **Patent No.:** **US D458,570 S**

(45) **Date of Patent:** **** Jun. 11, 2002**

(54) **VEHICLE EXHAUST TIP HAVING A SEALED FRONT SECTION AND A LOWER EXHAUST PORT**

D394,236 S * 5/1998 Verlengiere D12/194
D397,661 S * 9/1998 Harutiunian D12/194
6,085,863 A * 7/2000 Shuen 181/228
D440,531 S * 4/2001 Nagae D12/194

(76) **Inventor:** **Calvin Wang**, 768 S. Turnbull Canyon Rd., City of Industry, CA (US) 91745

* cited by examiner

(**) **Term:** **14 Years**

Primary Examiner—Stacia Cadmus

(74) *Attorney, Agent, or Firm*—Albert O. Cota

(21) **Appl. No.:** **29/143,245**

(57) **CLAIM**

(22) **Filed:** **Jun. 11, 2001**

The ornamental design for a vehicle exhaust tip having a sealed front section and a lower exhaust port, as shown and described.

(51) **LOC (7) Cl.** **12-16**

(52) **U.S. Cl.** **D12/194**

(58) **Field of Search** D12/194; D15/5;
181/227-228, 247-249, 264, 282, 239,
241

DESCRIPTION

(56) **References Cited**

U.S. PATENT DOCUMENTS

D164,202 S * 8/1951 Russell D12/194
D164,960 S * 10/1951 Russell D12/194
D174,659 S * 5/1955 Russell D12/194
D246,038 S * 10/1977 Moller D12/194
D384,319 S * 9/1997 Harutiunian D12/194
D392,928 S * 3/1998 Erion et al. D12/194

FIG. 1 is a perspective view of a vehicle exhaust tip having a sealed front section and a lower exhaust port showing my new design. The vehicle tail pipe is shown in broken lines for illustrative purposes only and forms no part of the claimed invention,

FIG. 2 is a right side elevational view thereof, the left side being a mirror image; thereof;

FIG. 3 is a top plan view thereof;

FIG. 4 is a bottom plan view thereof; and,

FIG. 5 is a front elevational view thereof.

1 Claim, 3 Drawing Sheets

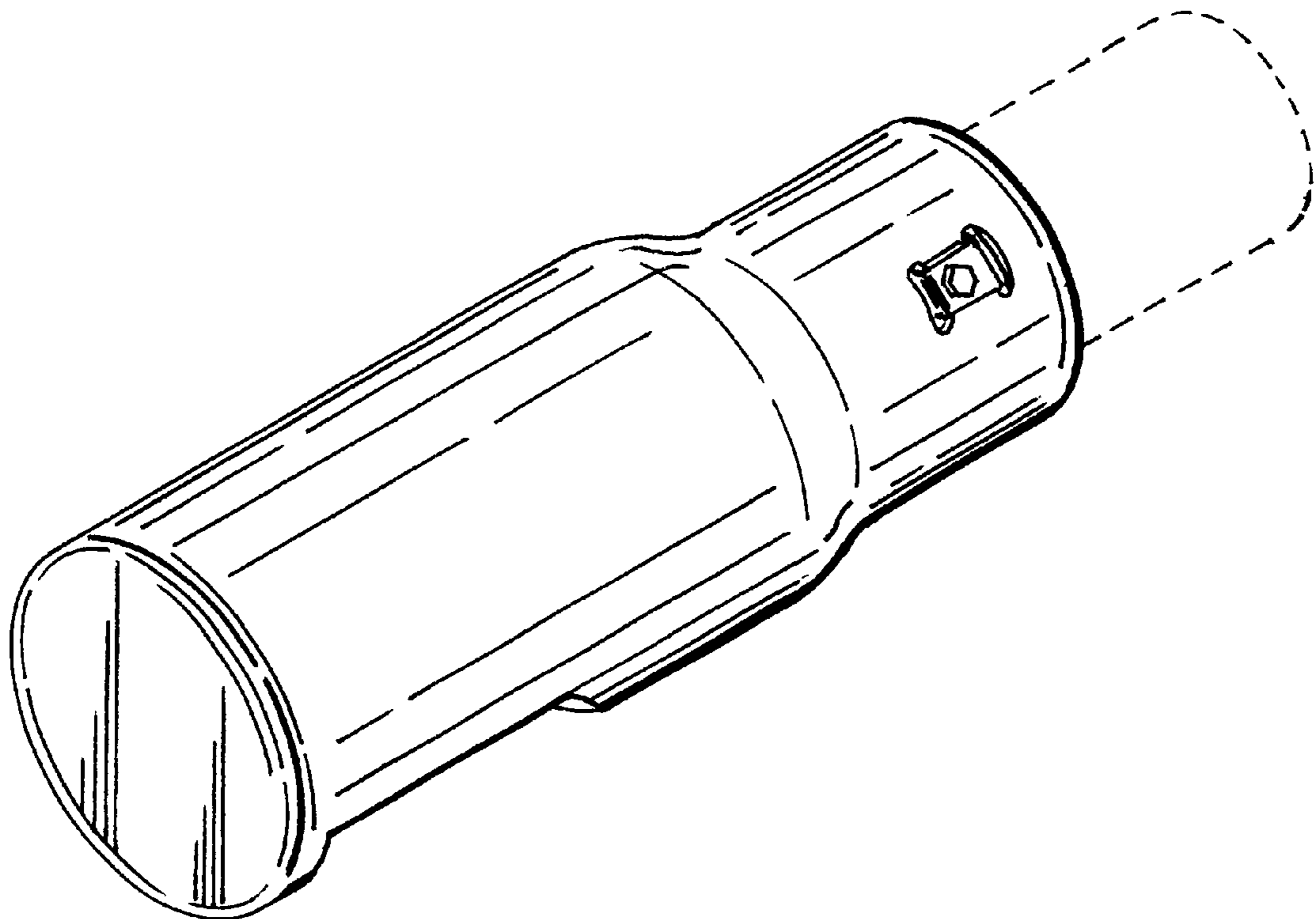

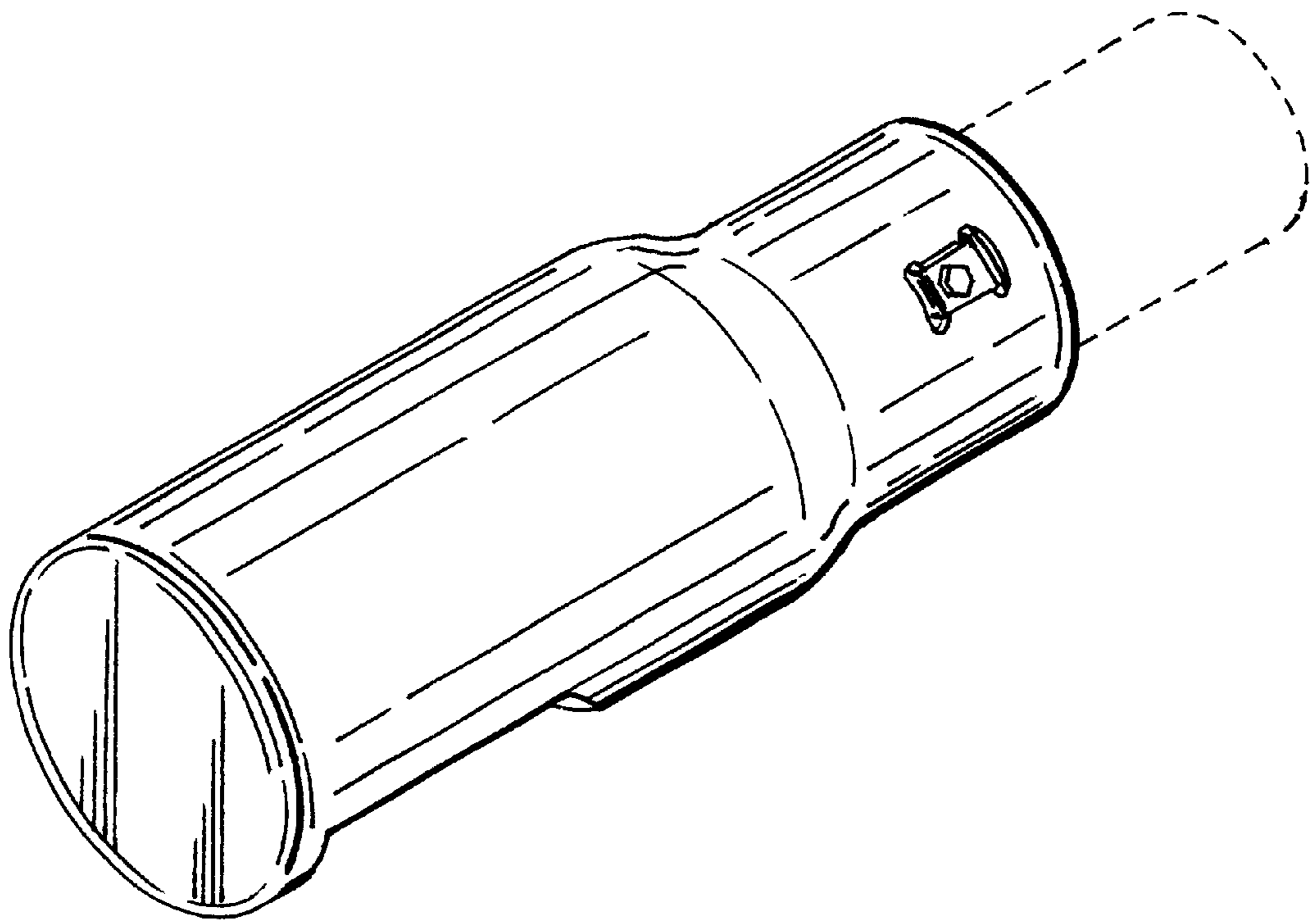

Fig.1.

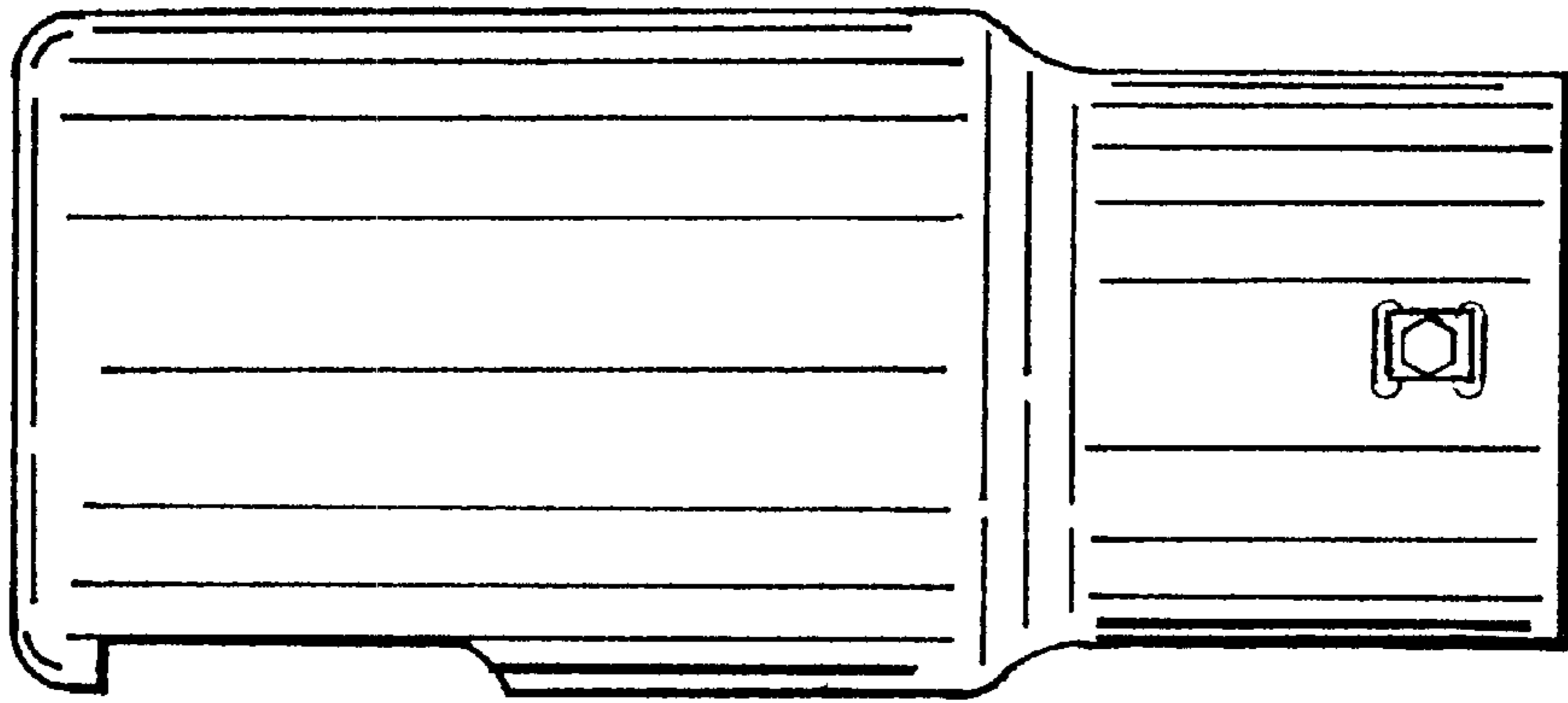

Fig. 2.

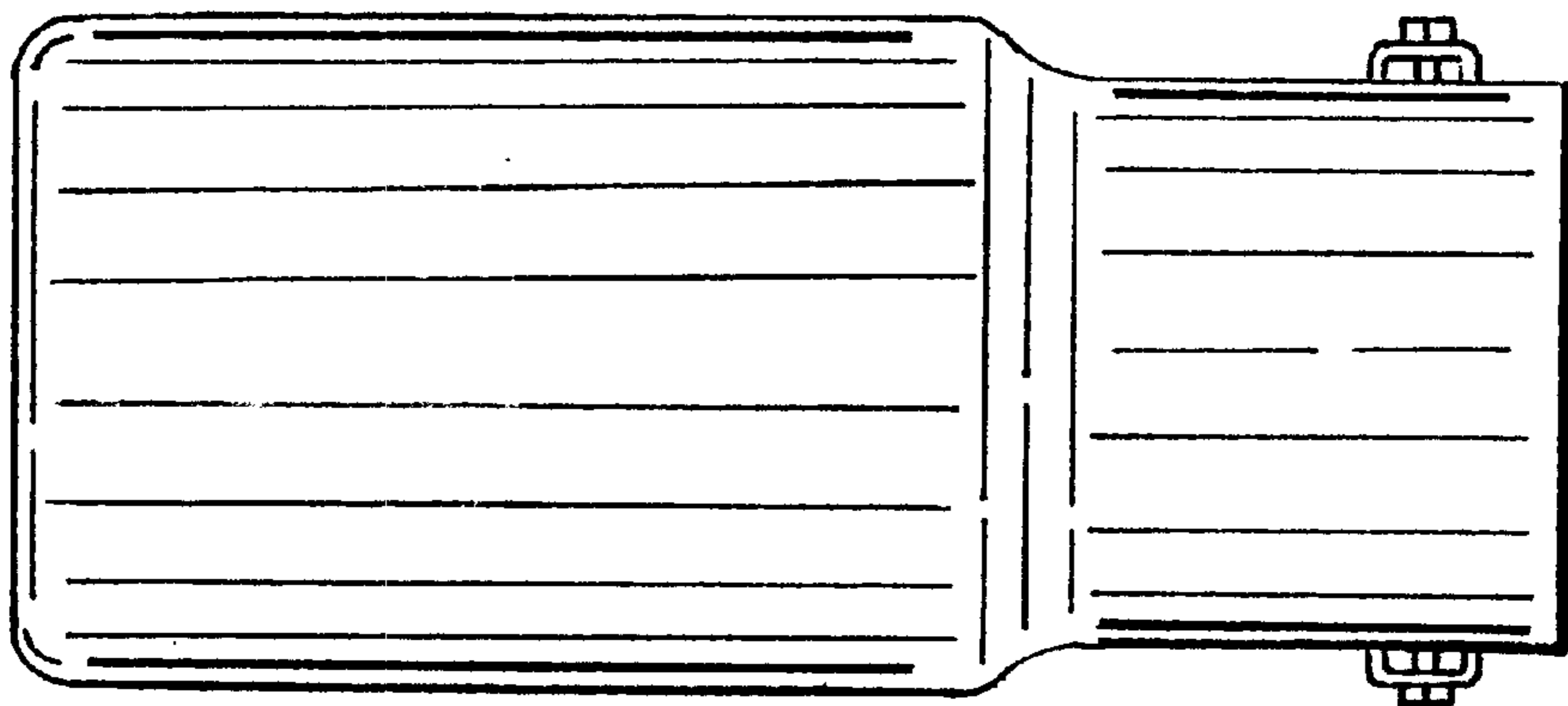

Fig. 3.

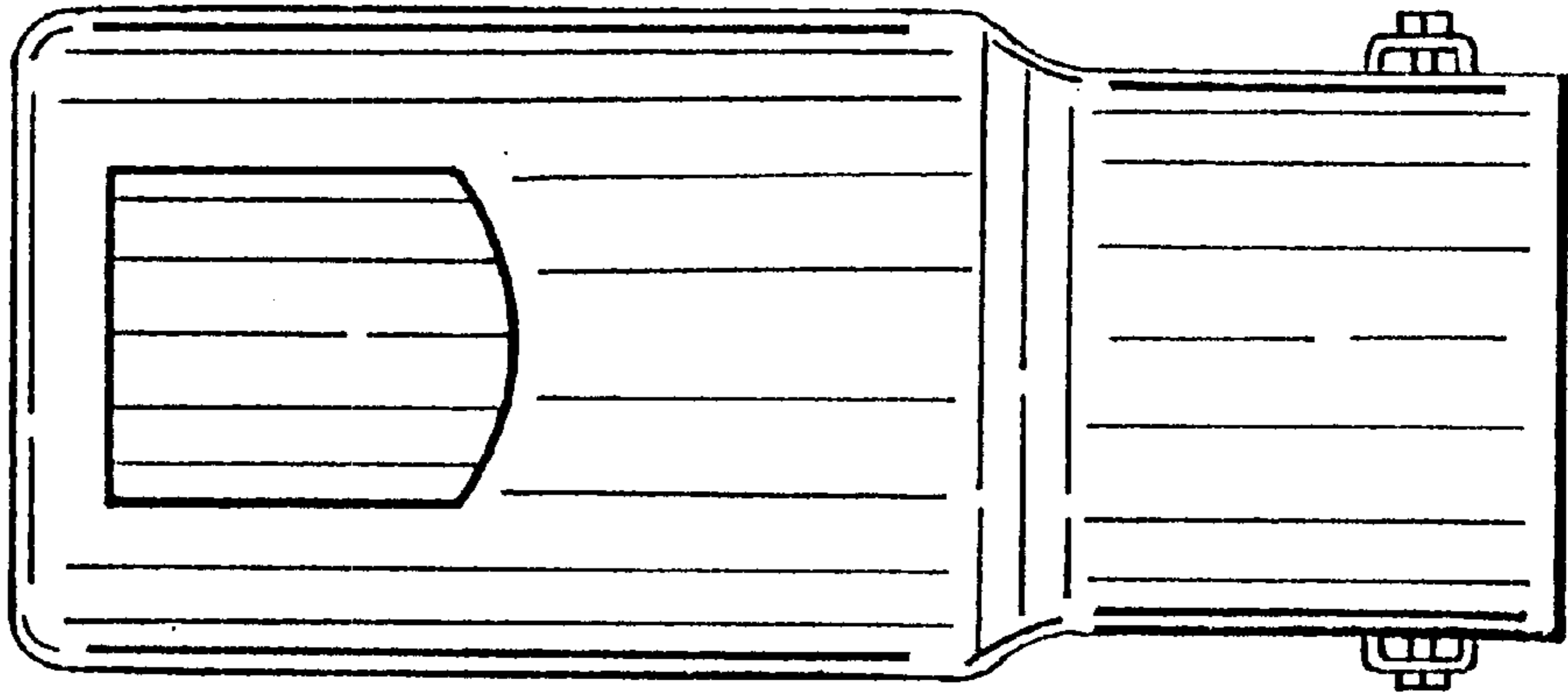

Fig. 4.

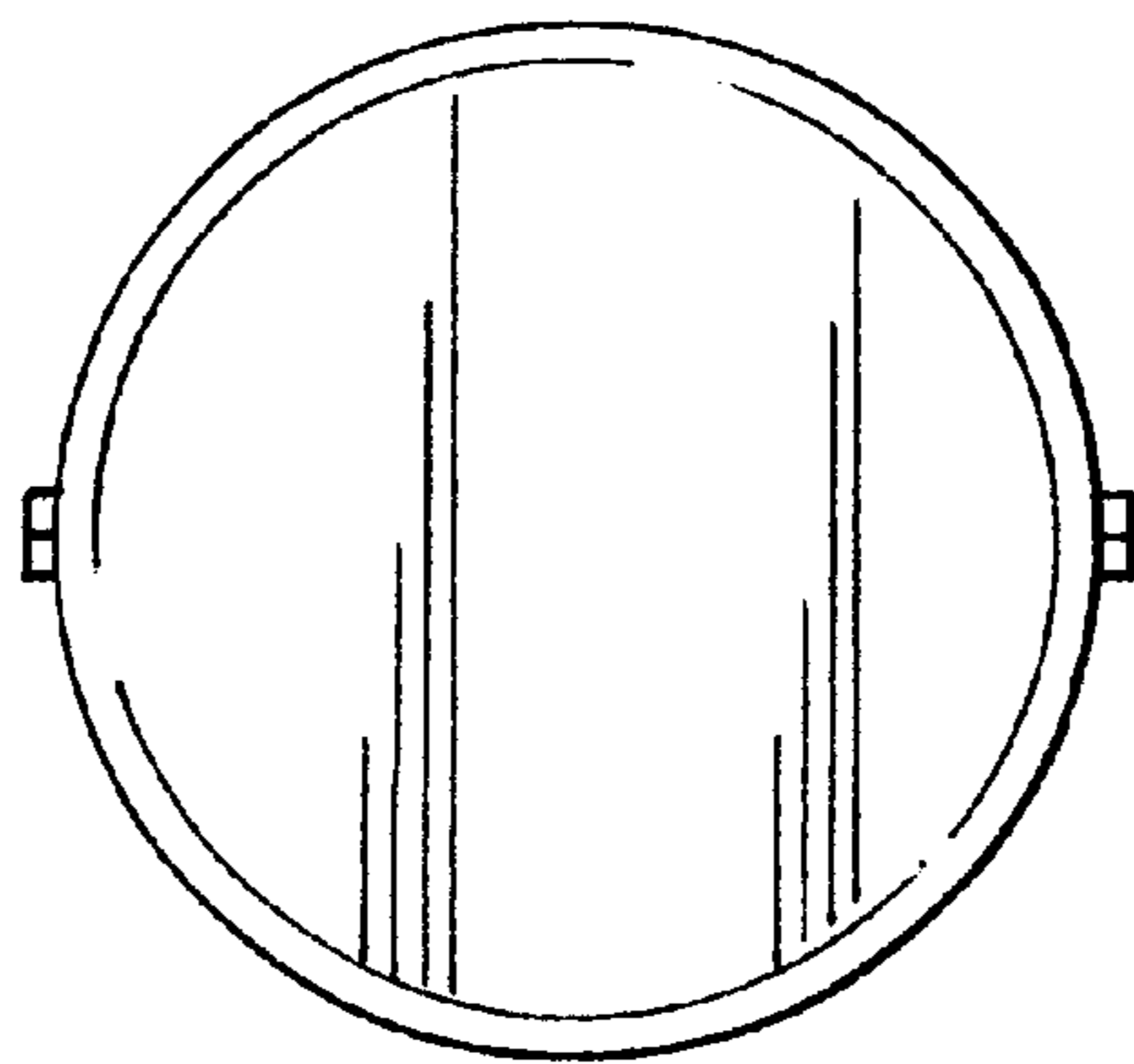

Fig. 5.