



US00D458566S

(12) **United States Design Patent**
Carlini

(10) **Patent No.:** **US D458,566 S**

(45) **Date of Patent:** **** Jun. 11, 2002**

(54) **MOTORCYCLE HANDLEBAR ASSEMBLY**

(76) Inventor: **Anthony J. Carlini**, 5 Geneve,
Newport Beach, CA (US) 92660

(**) Term: **14 Years**

(21) Appl. No.: **29/141,740**

(22) Filed: **May 10, 2001**

(51) **LOC (7) Cl.** **12-16**

(52) **U.S. Cl.** **D12/178**

(58) **Field of Search** D12/110, 114,
D12/178, 118; 180/219, 311; 74/551.1-551.9;
280/288.1-288.4, 274-280

(56) **References Cited**

U.S. PATENT DOCUMENTS

D342,475 S * 12/1993 Haro D12/178

OTHER PUBLICATIONS

Harley Owners Group ® Jan./Feb. 2000 Hog Tales ®
magazine, vol. 18/No. 1, handlebar unit illustrated on
cover.*

* cited by examiner

Primary Examiner—Alan P. Douglas

Assistant Examiner—Linda Brooks

(74) *Attorney, Agent, or Firm*—Roy A. Ekstrand

(57) **CLAIM**

The ornamental design for a motorcycle handlebar assembly, as shown and described.

DESCRIPTION

FIG. 1 sets forth a perspective view of a motorcycle handlebar assembly showing the present invention new design;

FIG. 2 is a top plan view thereof;

FIG. 3 is a rear view thereof;

FIG. 4 is a bottom view thereof;

FIG. 5 is a front view thereof; and,

FIG. 6 is a left side view thereof, the right side being a mirror image thereof.

The broken lines shown form no part of the claimed design.

1 Claim, 3 Drawing Sheets

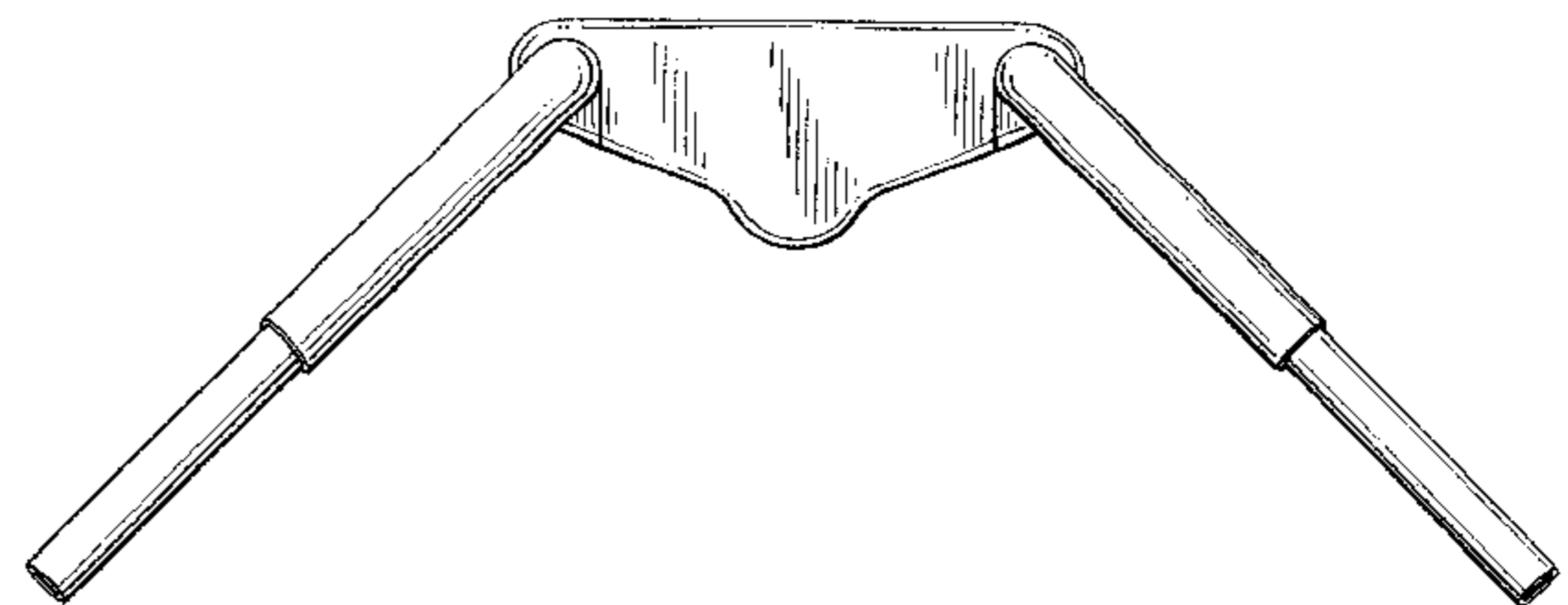
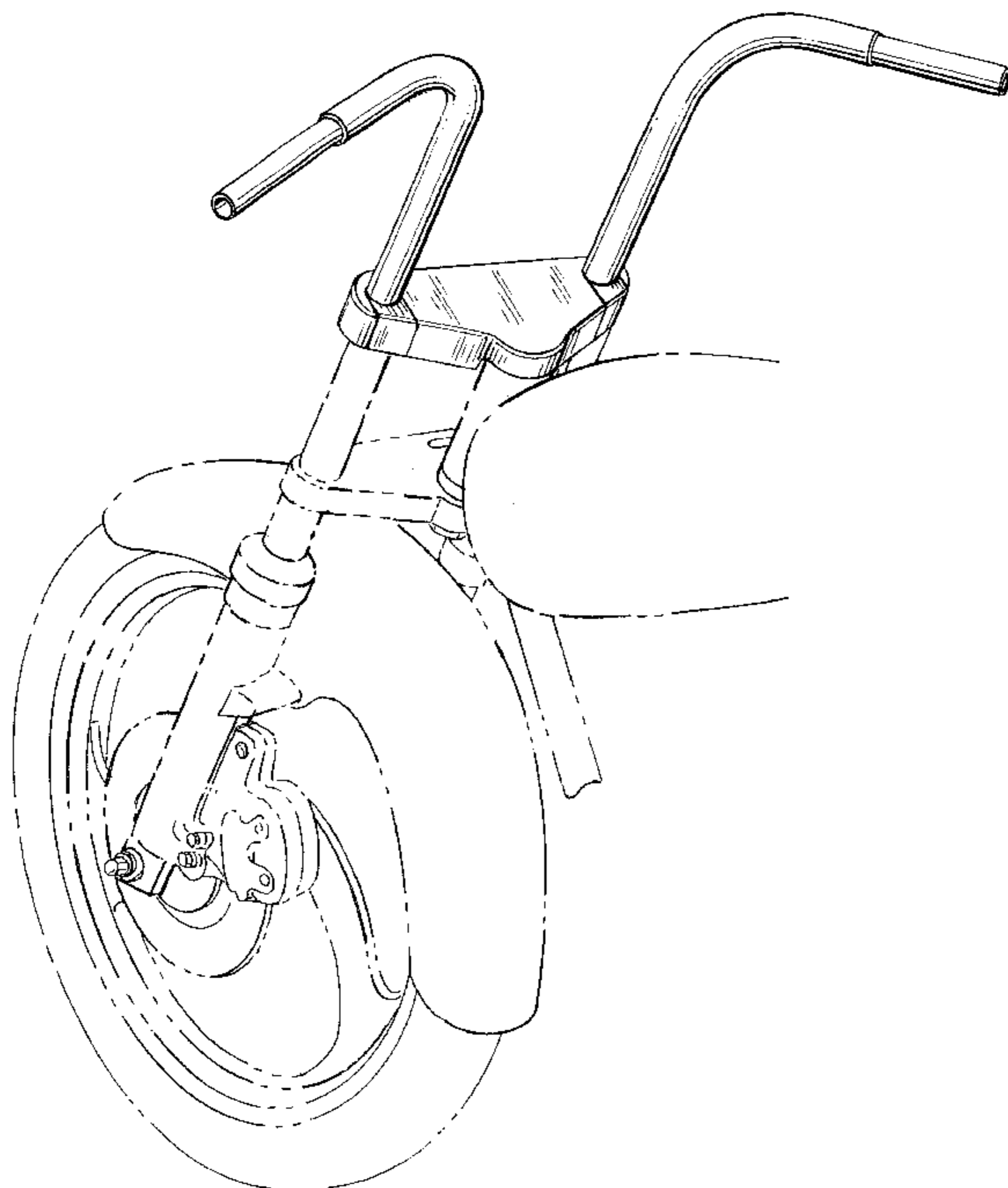

FIG. 1

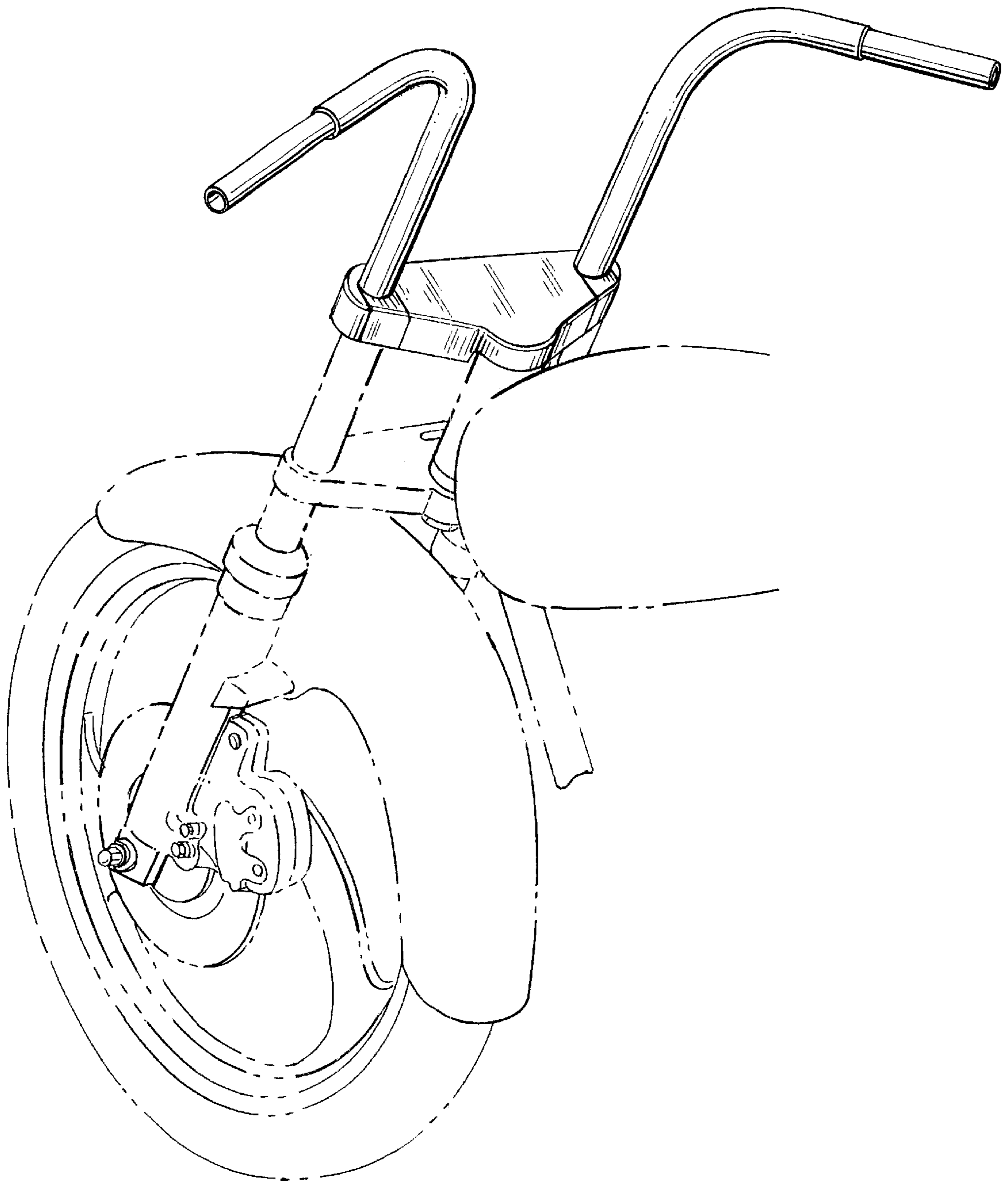

FIG. 2

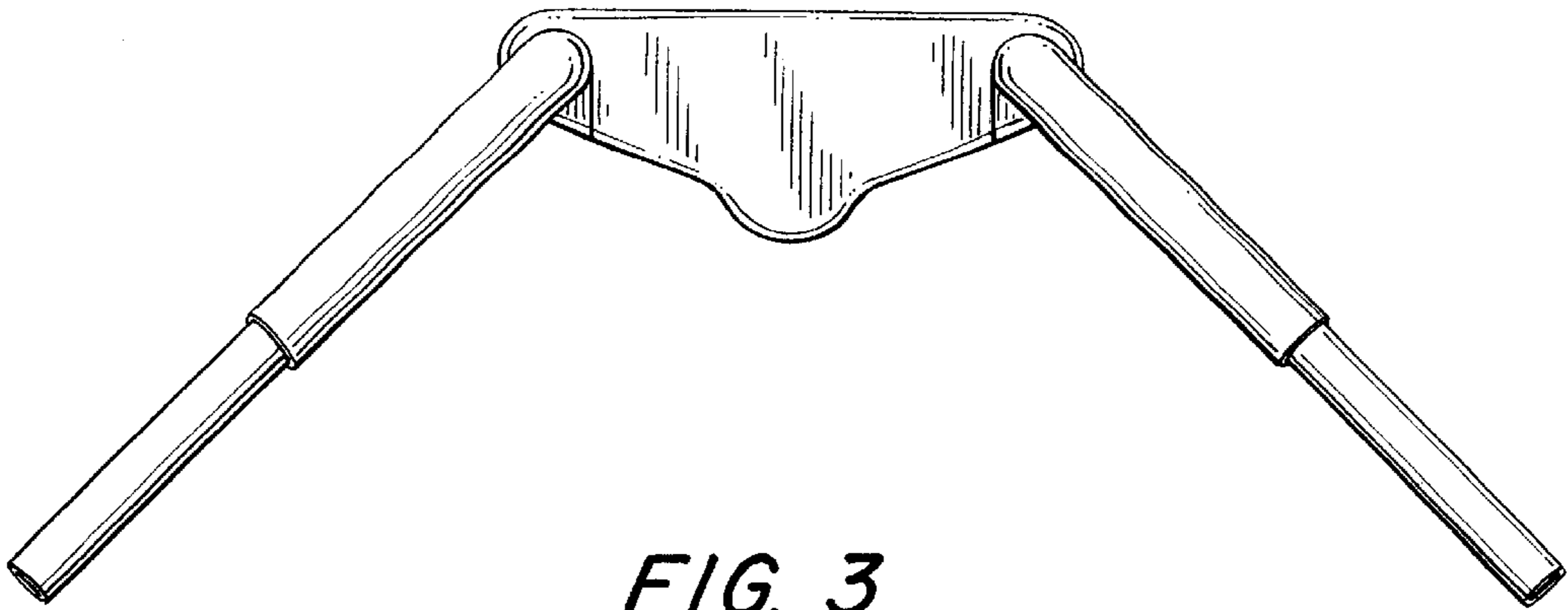

FIG. 3

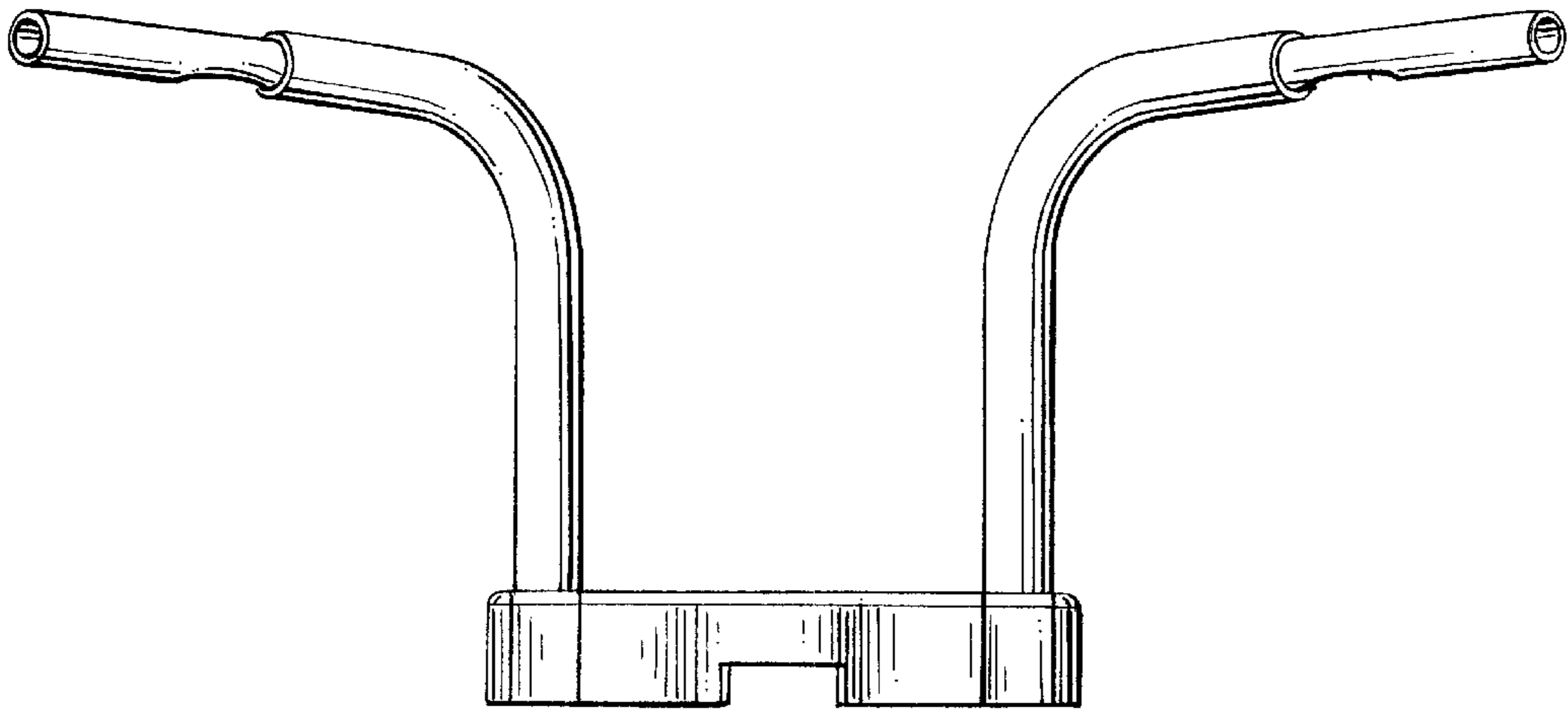

FIG. 4

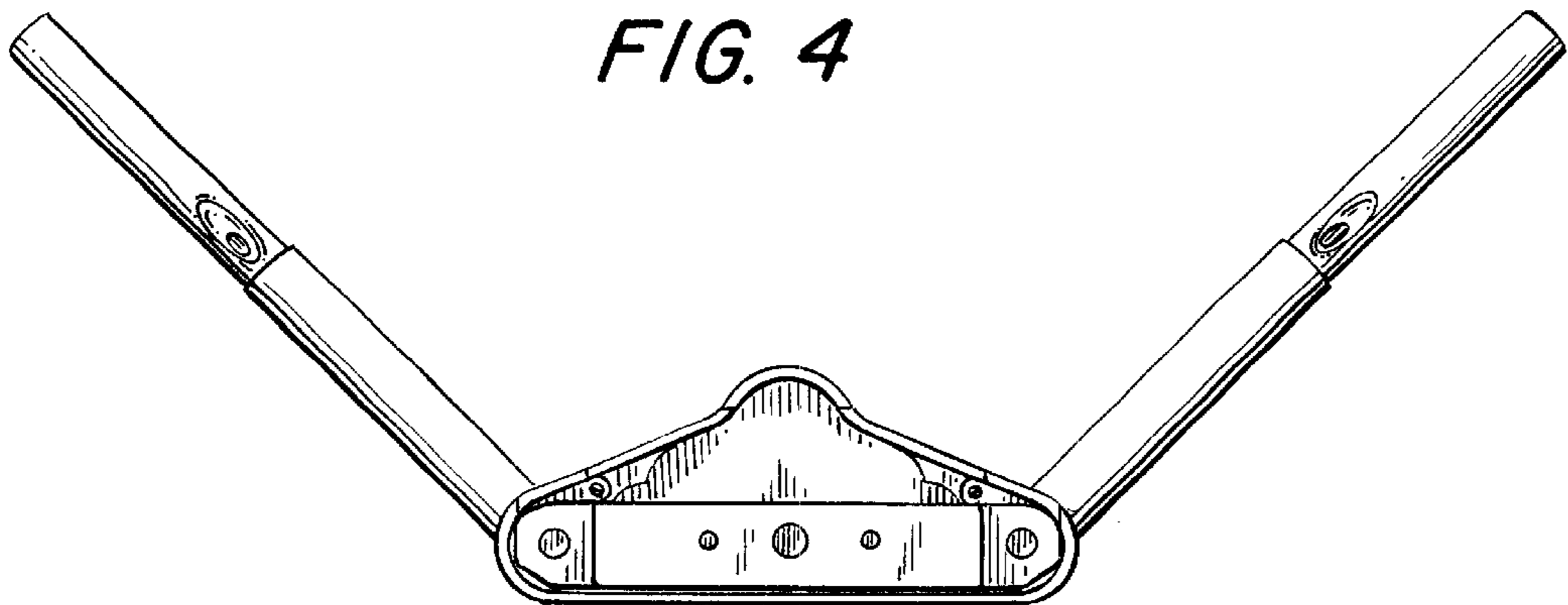

FIG. 5

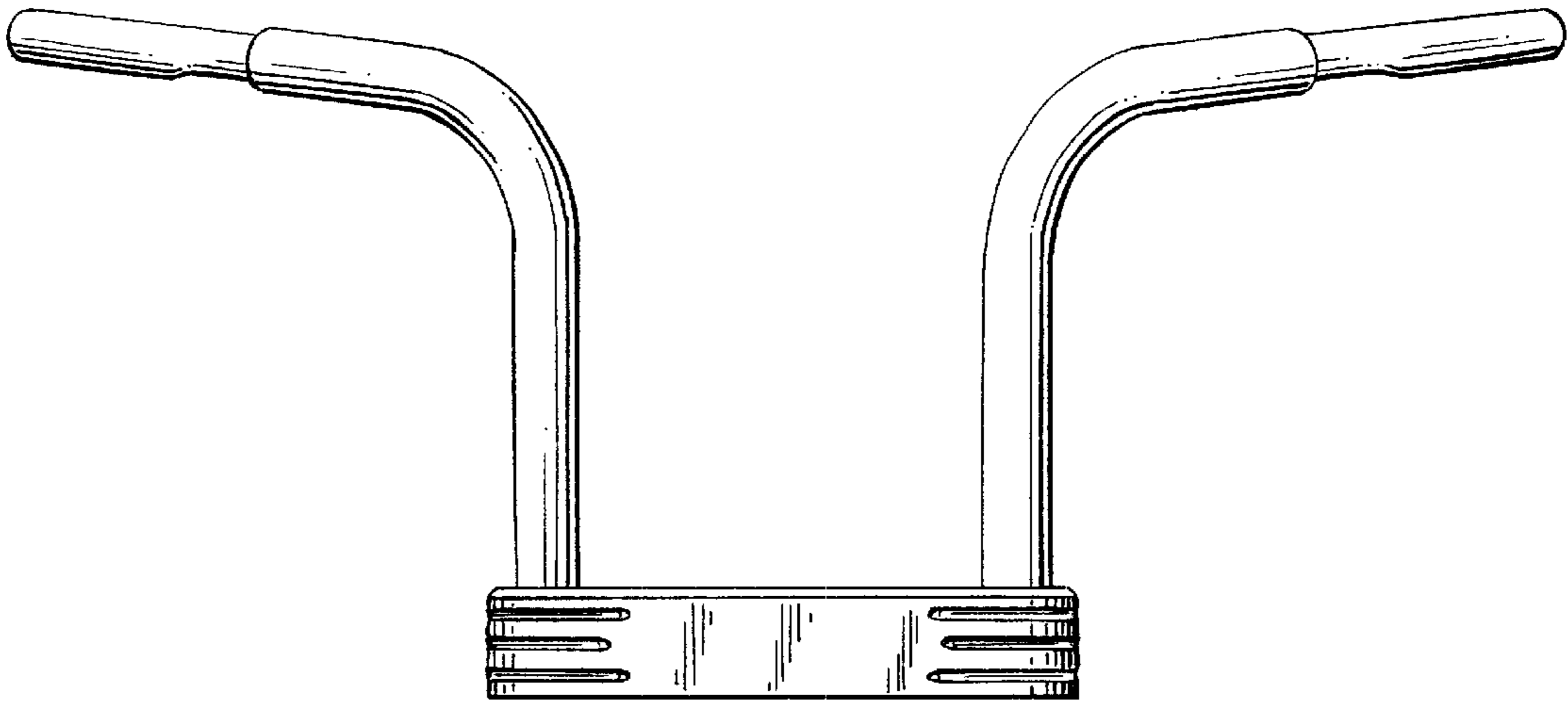

FIG. 6

