



US00D458143S

(12) **United States Design Patent**
Ackerman

(10) **Patent No.:** **US D458,143 S**

(45) **Date of Patent:** **** Jun. 4, 2002**

(54) **BOTTLE**

(75) **Inventor:** **Linda L. Ackerman**, Wilton Manors,
FL (US)

(73) **Assignee:** **Parlux Fragrances, Inc.**, Fort
Lauderdale, FL (US)

(**) **Term:** **14 Years**

(21) **Appl. No.:** **29/135,028**

(22) **Filed:** **Jan. 3, 2001**

(51) **LOC (7) Cl.** **09-01**

(52) **U.S. Cl.** **D9/549; D9/517; D9/575**

(58) **Field of Search** D9/500-504, 516,
D9/545, 549, 557, 562, 574, 575, 300,
537, 538, 541, 570, 337, 446; D28/88;
215/12.2, 381-384, 396, 398, 400

(56) **References Cited**

U.S. PATENT DOCUMENTS

- 1,118,395 A * 11/1914 Campbell 215/396
- 1,635,789 A * 7/1927 Hyman
- 1,750,672 A * 3/1930 Krischer 215/11.6
- D89,750 S * 5/1933 Ferris D28/88
- D93,940 S * 11/1934 McManus D9/500
- D137,943 S * 5/1944 Schlumbohm 215/383
- 2,414,901 A * 1/1947 Schlumbohm 215/396
- D152,938 S * 3/1949 Bocher D9/503

- 2,538,684 A * 1/1951 Gushard et al. 215/382
- 2,745,569 A * 5/1956 Seaman 215/12.1
- 3,093,255 A * 6/1963 Mesrobian et al. 215/400
- D222,032 S * 9/1971 Donogohs D9/501
- D225,616 S * 12/1972 Bagn D9/501
- D234,293 S * 2/1975 Toland D9/504
- 4,190,168 A * 2/1980 Jacques 215/12.2
- 4,796,937 A * 1/1989 Andrea 215/396
- D351,337 S * 10/1994 Bonnema et al. D9/300
- D378,492 S * 3/1997 Salle D9/300
- D412,661 S * 8/1999 Lavigne D9/300
- D419,061 S * 1/2000 Croft et al. D9/542 X
- D446,121 S * 8/2001 Maddy D9/500

* cited by examiner

Primary Examiner—Ted Shooman

Assistant Examiner—Carol Rademaker

(74) *Attorney, Agent, or Firm*—Blakely, Sokoloff, Taylor &
Zafman LLP

(57) **CLAIM**

The ornamental design for a bottle, as shown and described.

DESCRIPTION

FIG. 1 is a perspective view showing the front, top and right side of a first embodiment of my new design; and, FIG. 2 is a perspective view showing the front, top and right side of a second embodiment of my new design.

1 Claim, 1 Drawing Sheet

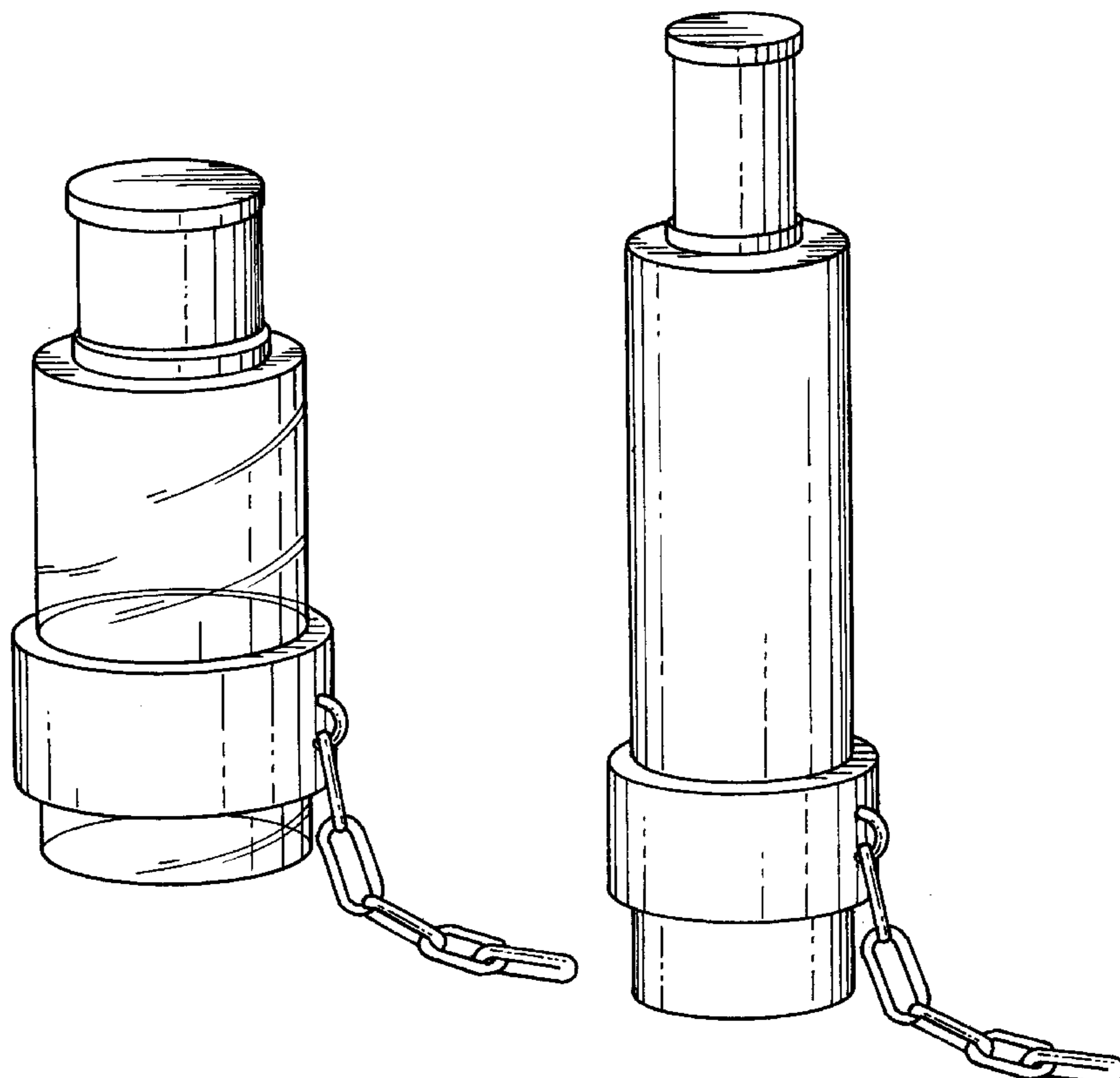

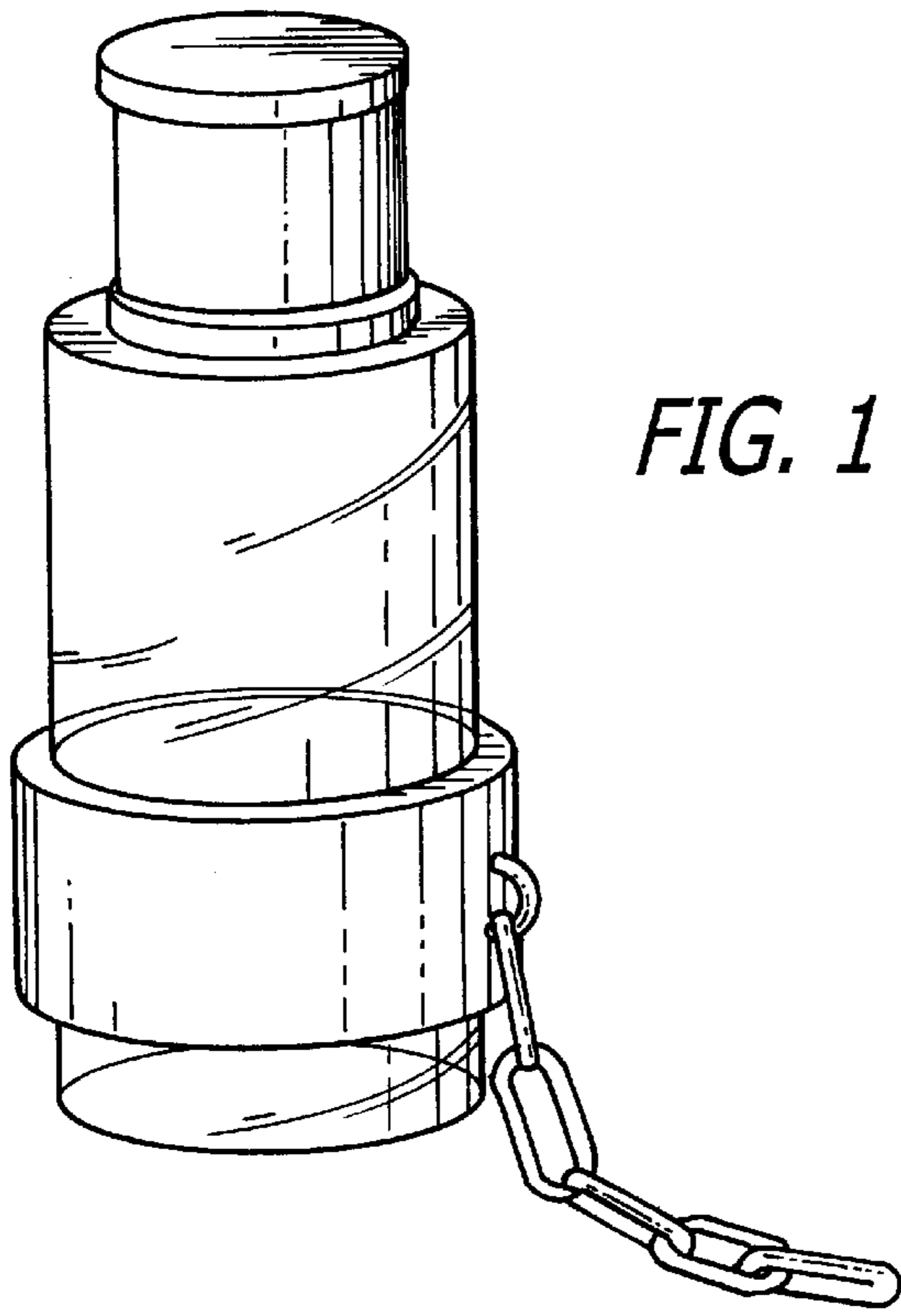

FIG. 1

FIG. 2

