



US00D458131S

(12) **United States Design Patent**
Weber

(10) **Patent No.:** **US D458,131 S**

(45) **Date of Patent:** **** Jun. 4, 2002**

(54) **CLOSED RING TRASH BAG HOLDER**

(76) **Inventor:** **Paul W. Weber**, 205 Blue Heron Rd.,
Wellfleet, MA (US) 02667

(**) **Term:** **14 Years**

(21) **Appl. No.:** **29/143,712**

(22) **Filed:** **Jun. 19, 2001**

(51) **LOC (7) Cl.** **09-07**

(52) **U.S. Cl.** **D9/434**

(58) **Field of Search** D9/434, 435, 499;
D34/5; 248/99-101

(56) **References Cited**

U.S. PATENT DOCUMENTS

D289,016	S	*	3/1987	Campbell	D9/434
4,775,123	A	*	10/1988	Borland et al.	248/99
4,832,292	A	*	5/1989	Beckham	248/99
4,867,401	A	*	9/1989	Graff	248/99
D324,441	S	*	3/1992	Werner	D34/5
D391,724	S	*	3/1998	Blackburn	D34/5

* cited by examiner

Primary Examiner—Dominic Simone
(74) *Attorney, Agent, or Firm*—Thomas A. Kahrl, Esq.

(57) **CLAIM**

I claim the ornamental design for closed ring trash bag holder, as shown and described.

DESCRIPTION

FIG. 1 is a perspective view of a closed ring trash bag holder showing my new design;
FIG. 2 is a top plan view thereof;
FIG. 3 is a front elevational view thereof;
FIG. 4 is a right side elevational view thereof the left side being a mirror image thereof;
FIG. 5 is a rear elevational view thereof;
FIG. 6 is a bottom plan view thereof.
FIG. 7 is a cross-section thereof taken along line 7—7 of FIG. 2; and,
FIG. 8 is a cross-section thereof taken along line 8—8 of FIG. 2.

1 Claim, 2 Drawing Sheets

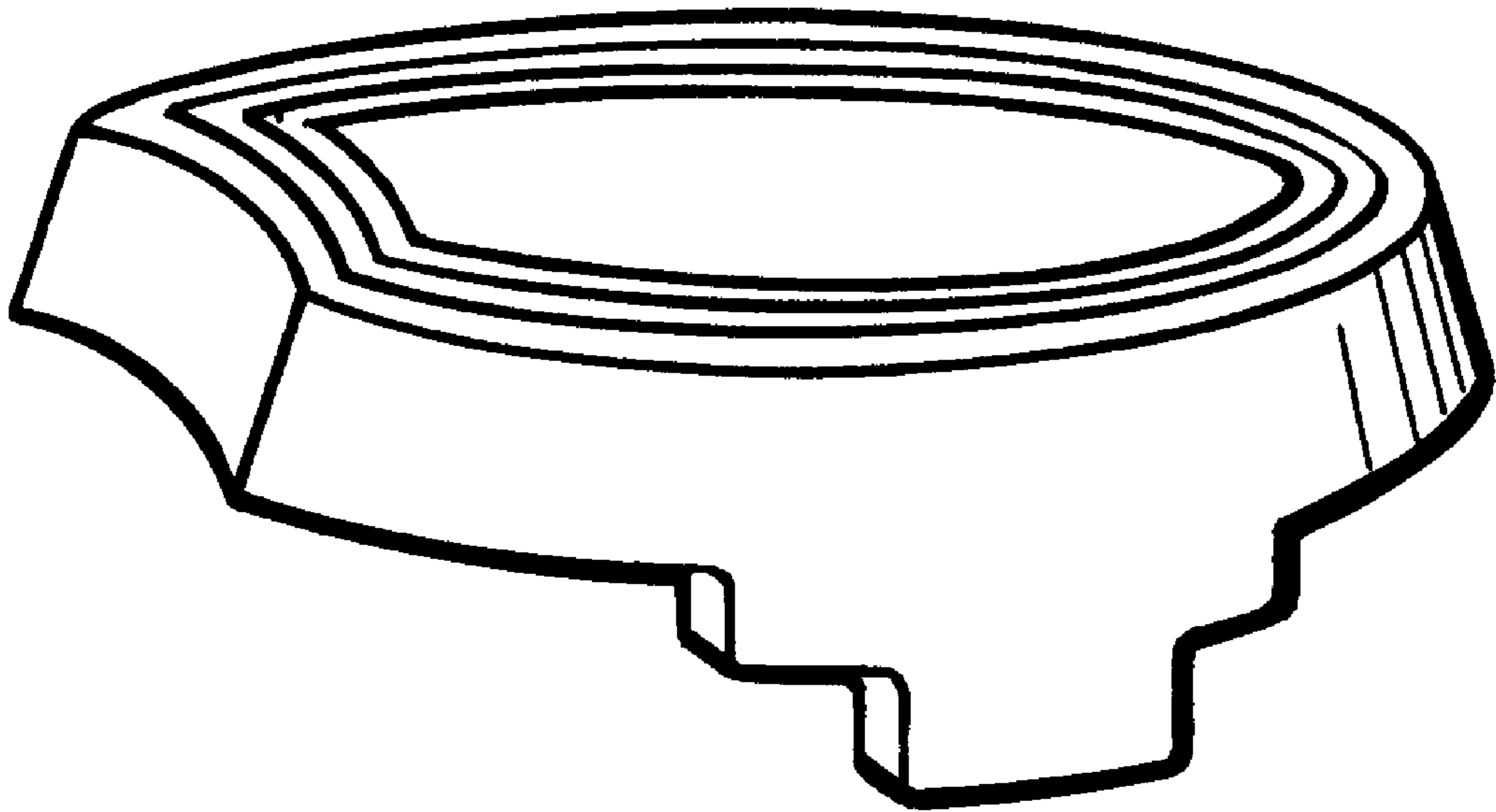

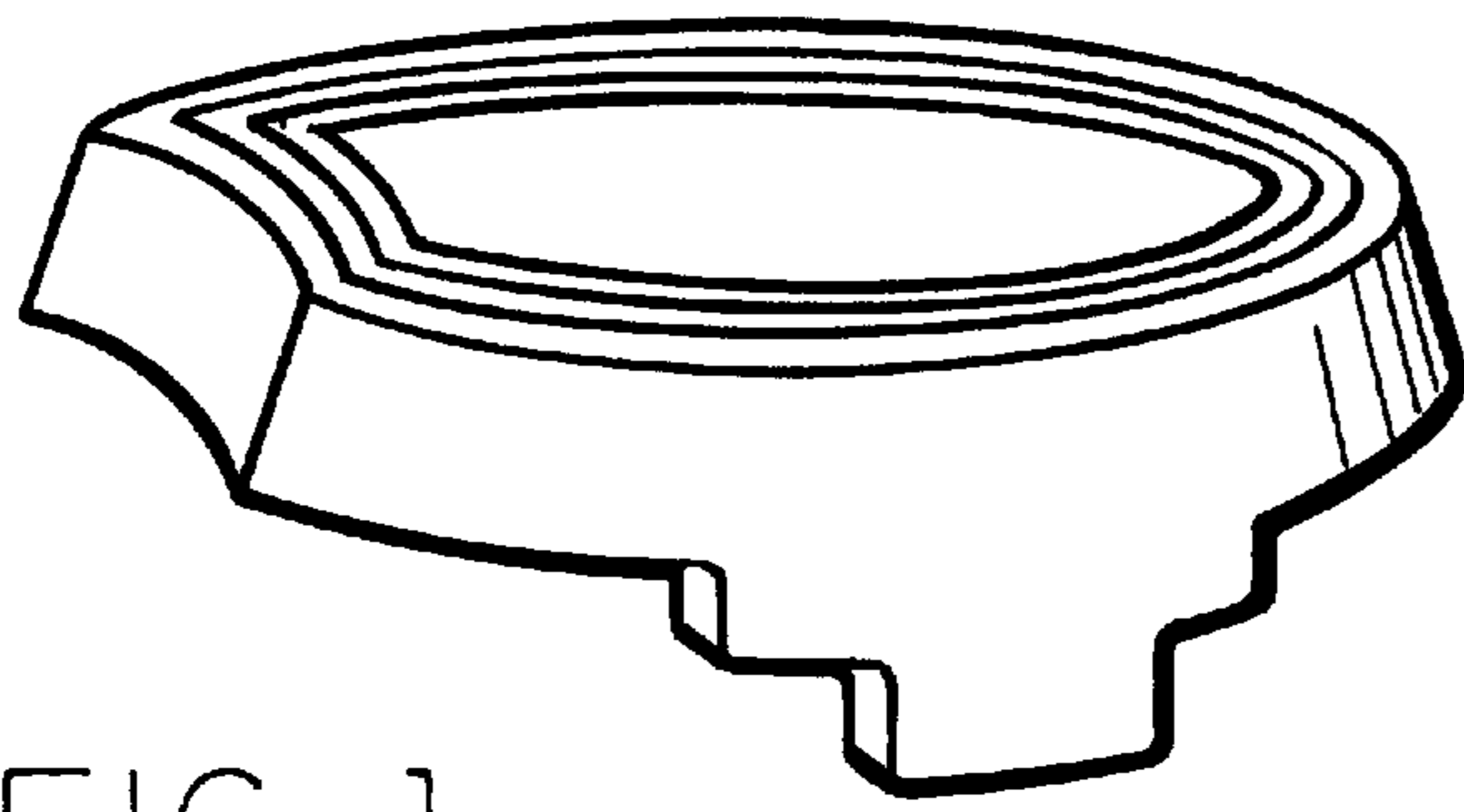

FIG. 1

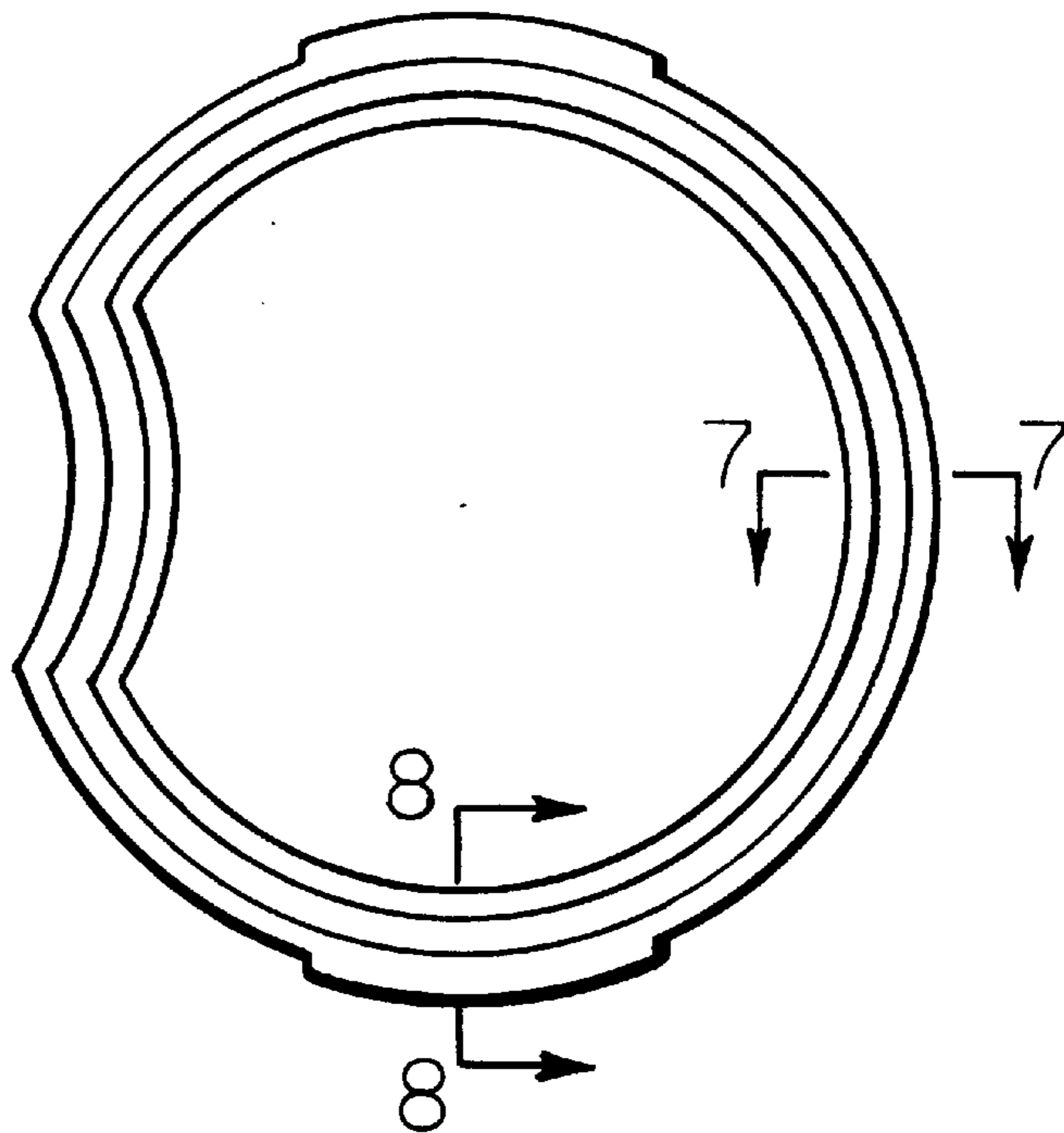

FIG. 2

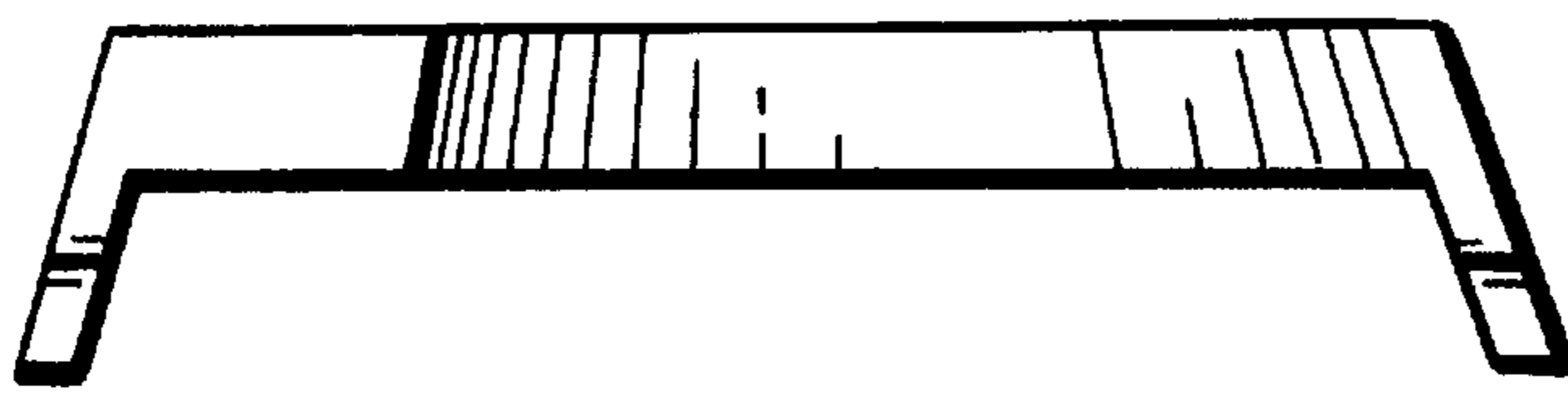

FIG. 3

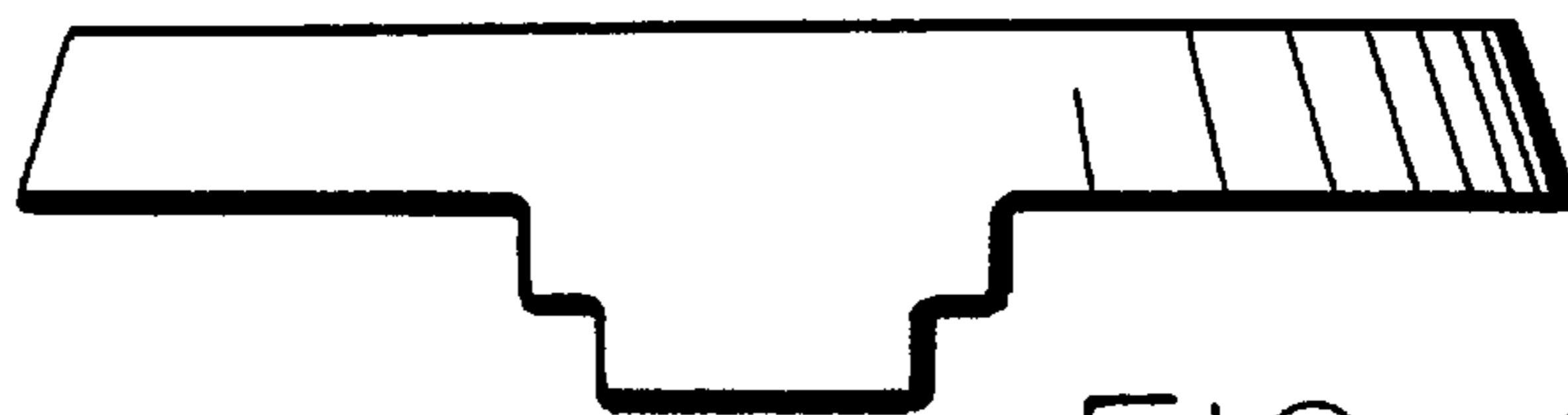

FIG. 4

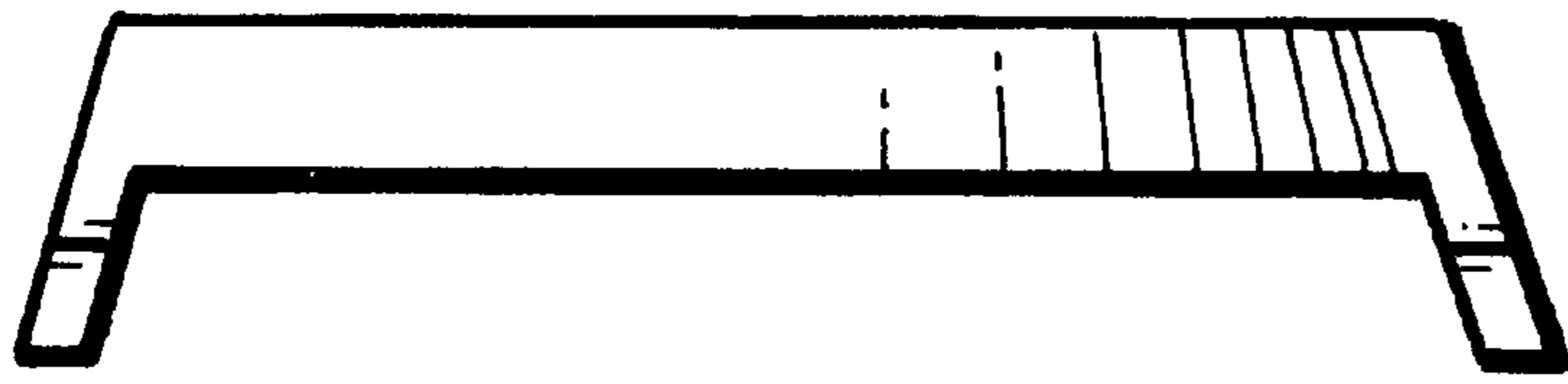

FIG. 5

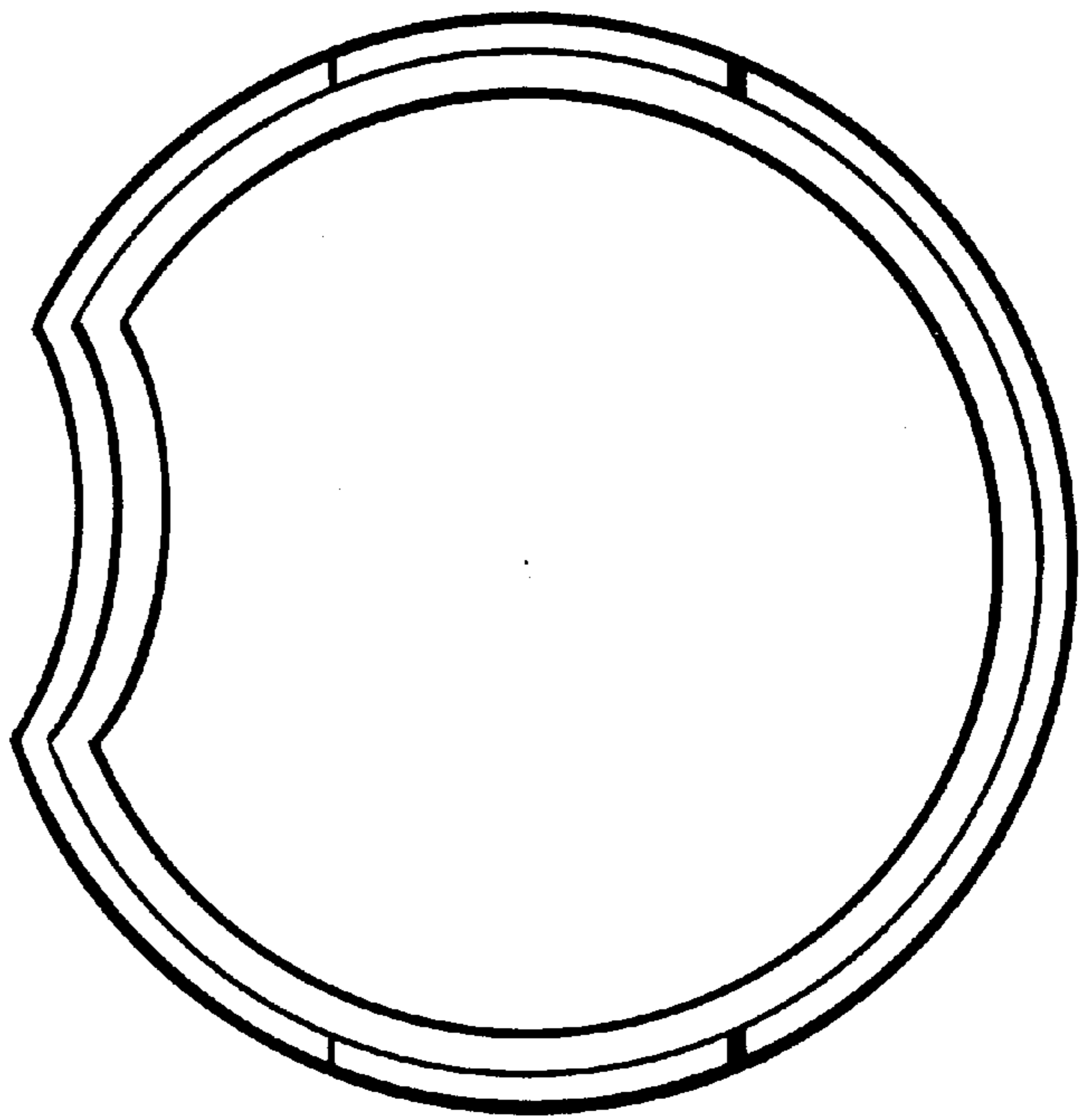

FIG. 6

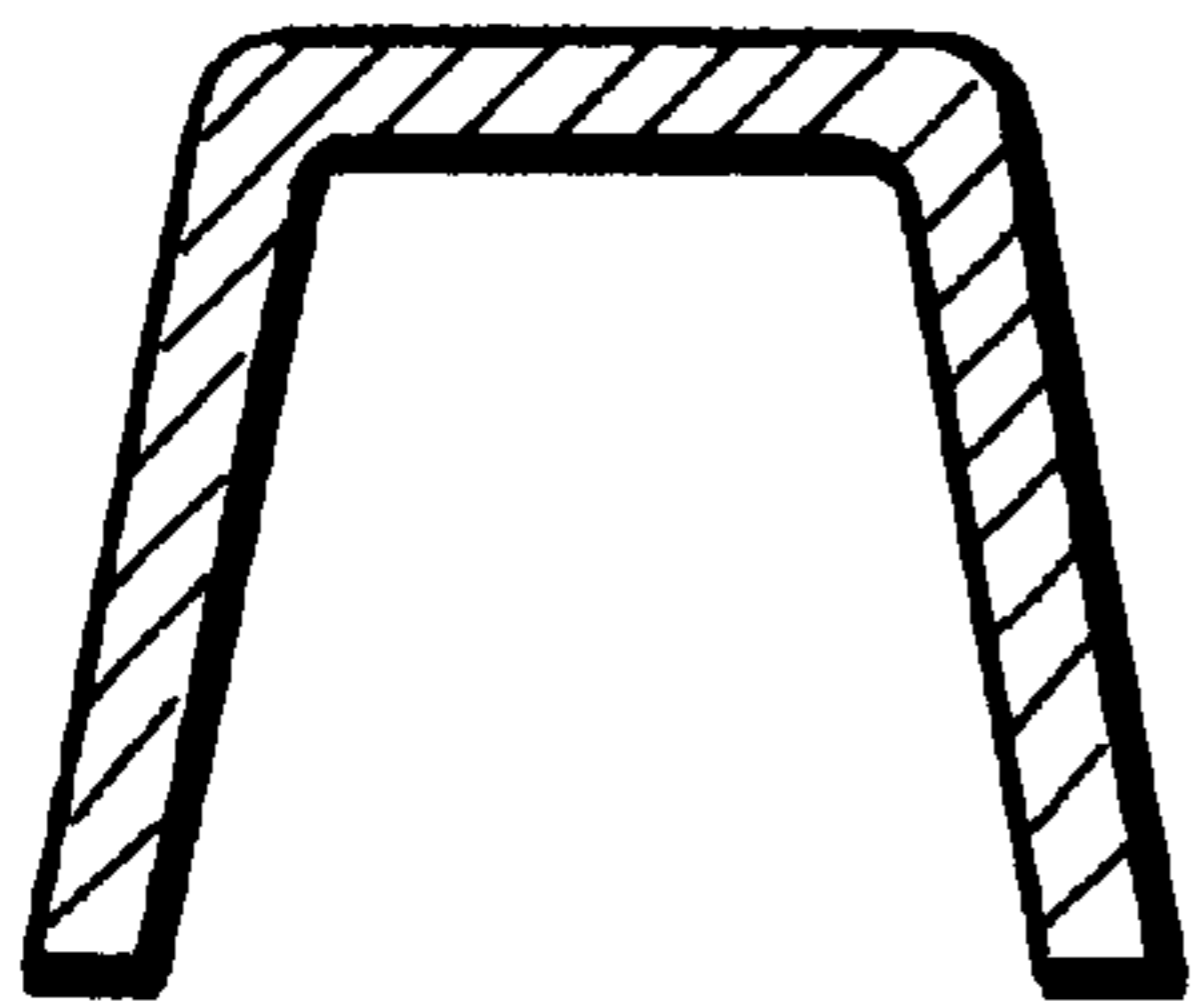

FIG. 7

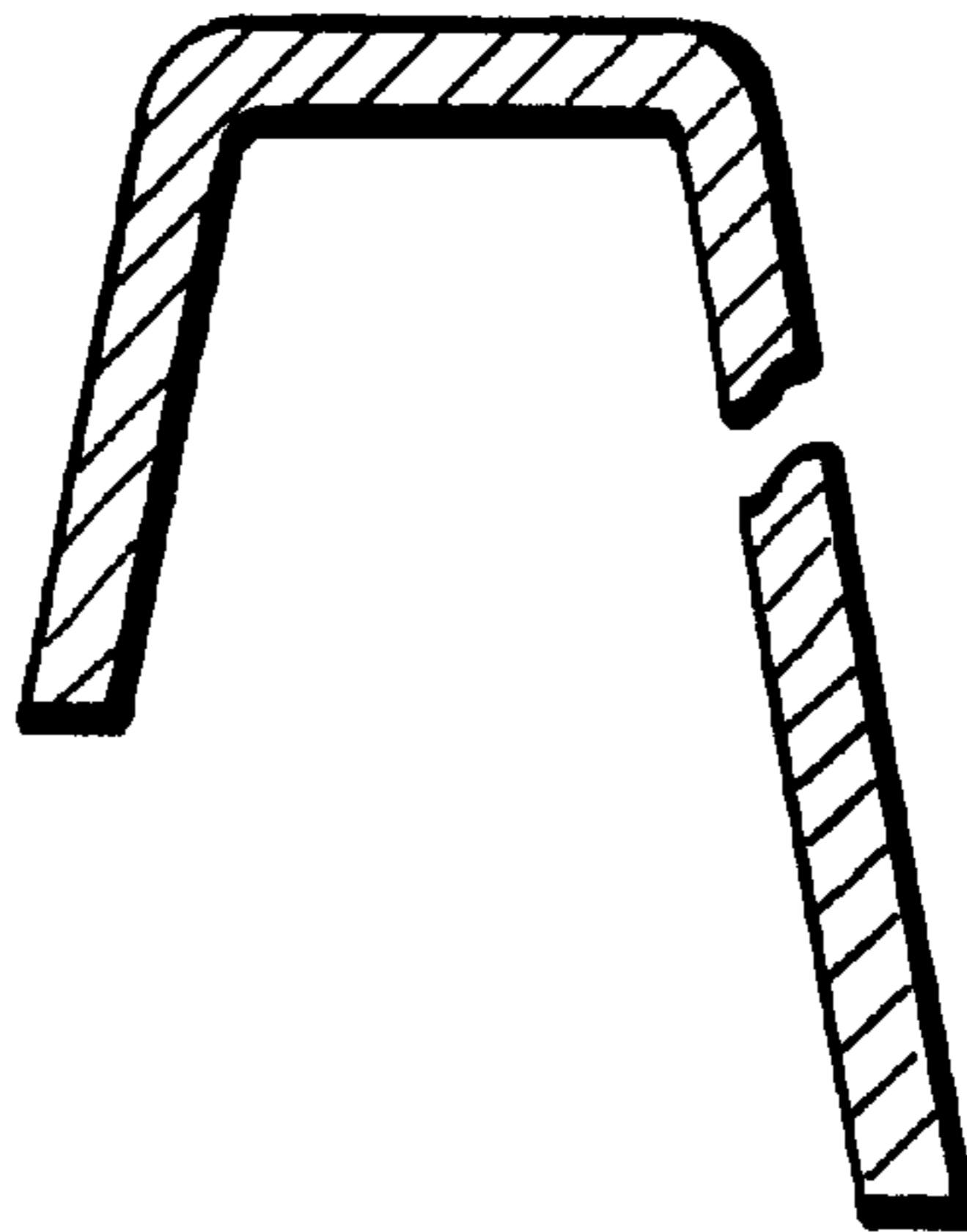

FIG. 8