



US00D457850S

(12) **United States Design Patent**  
**Rietsch**

(10) **Patent No.:** **US D457,850 S**

(45) **Date of Patent:** **\*\* May 28, 2002**

(54) **PROPELLER**

D431,627 S \* 10/2000 Etschel et al. .... D12/214

(75) Inventor: **Peter Rietsch**, Regnitzlosau (DE)

\* cited by examiner

(73) Assignee: **EMU Unterwasserpumpen GmbH**,  
Hof (DE)

*Primary Examiner*—Lisa Lichtenstein

(74) *Attorney, Agent, or Firm*—Schweitzer Cornman Gross  
& Bondell LLP

(\*\*) Term: **14 Years**

(57) **CLAIM**

(21) Appl. No.: **29/144,617**

The ornamental design for a propeller, as shown.

(22) Filed: **Jul. 6, 2001**

**DESCRIPTION**

(30) **Foreign Application Priority Data**

Jan. 20, 2001 (DE) ..... 401 00 499

(51) **LOC (7) Cl.** ..... **12-16**

(52) **U.S. Cl.** ..... **D12/214**

(58) **Field of Search** ..... D12/214, 30; D23/379;  
416/228, 223 R, 204 R, 235; 415/203;  
114/274

FIG. 1 is a perspective view of a new propeller in accordance with the present invention;

FIG. 2 is a top plan elevational view of the propeller of FIG. 1;

FIG. 3 is a right side elevational view of the propeller of FIG. 1;

FIG. 4 is a left side elevational view of the propeller of FIG. 1;

FIG. 5 is a front view of the propeller of FIG. 1 from flow direction; and,

FIG. 6 is a rear view of the propeller of FIG. 1 from the motor side.

(56) **References Cited**

**U.S. PATENT DOCUMENTS**

D158,058 S \* 4/1950 Engelke ..... D12/214

D341,608 S \* 11/1993 Fries ..... D12/214

**1 Claim, 5 Drawing Sheets**

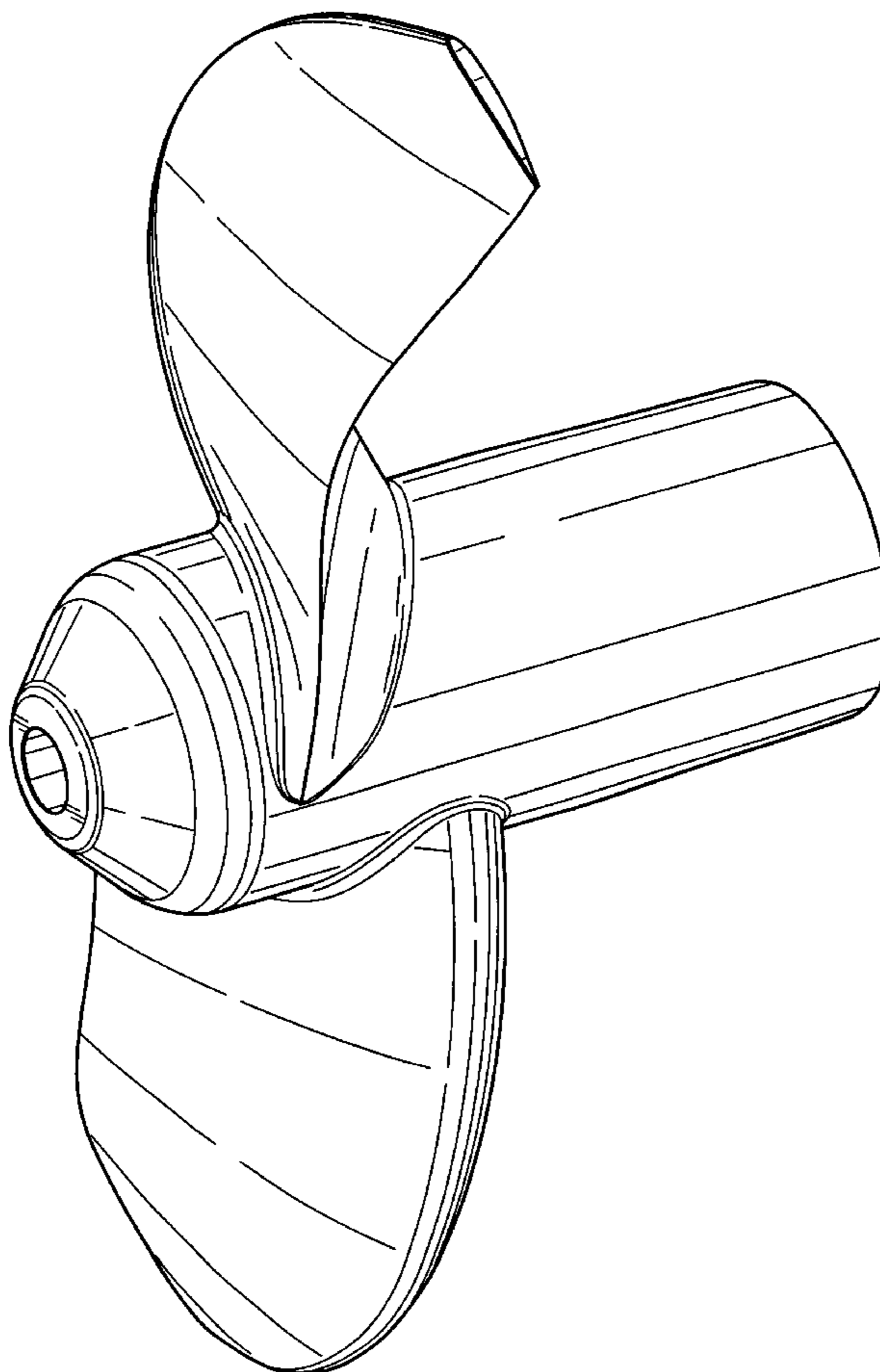

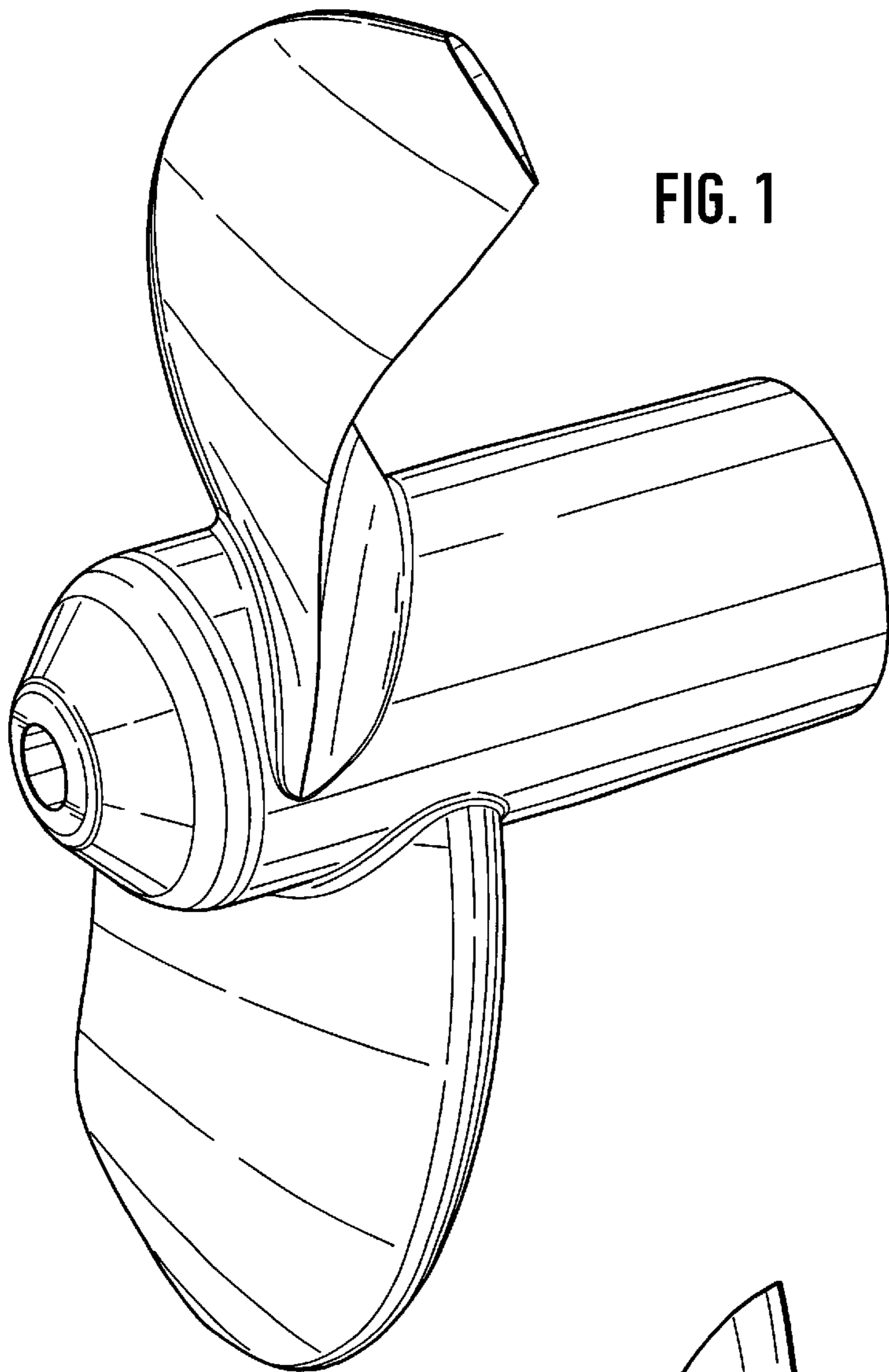

FIG. 1

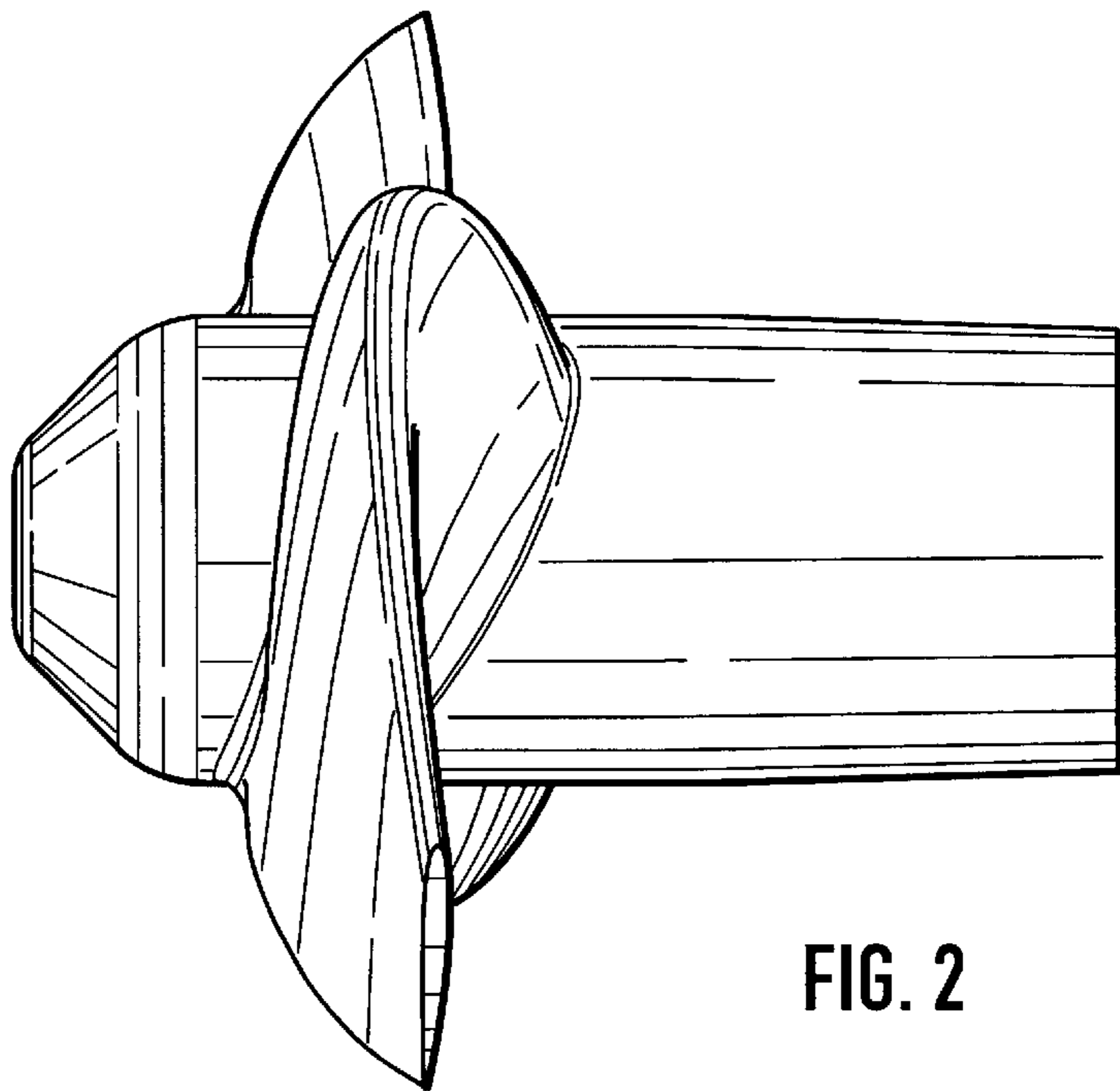

FIG. 2

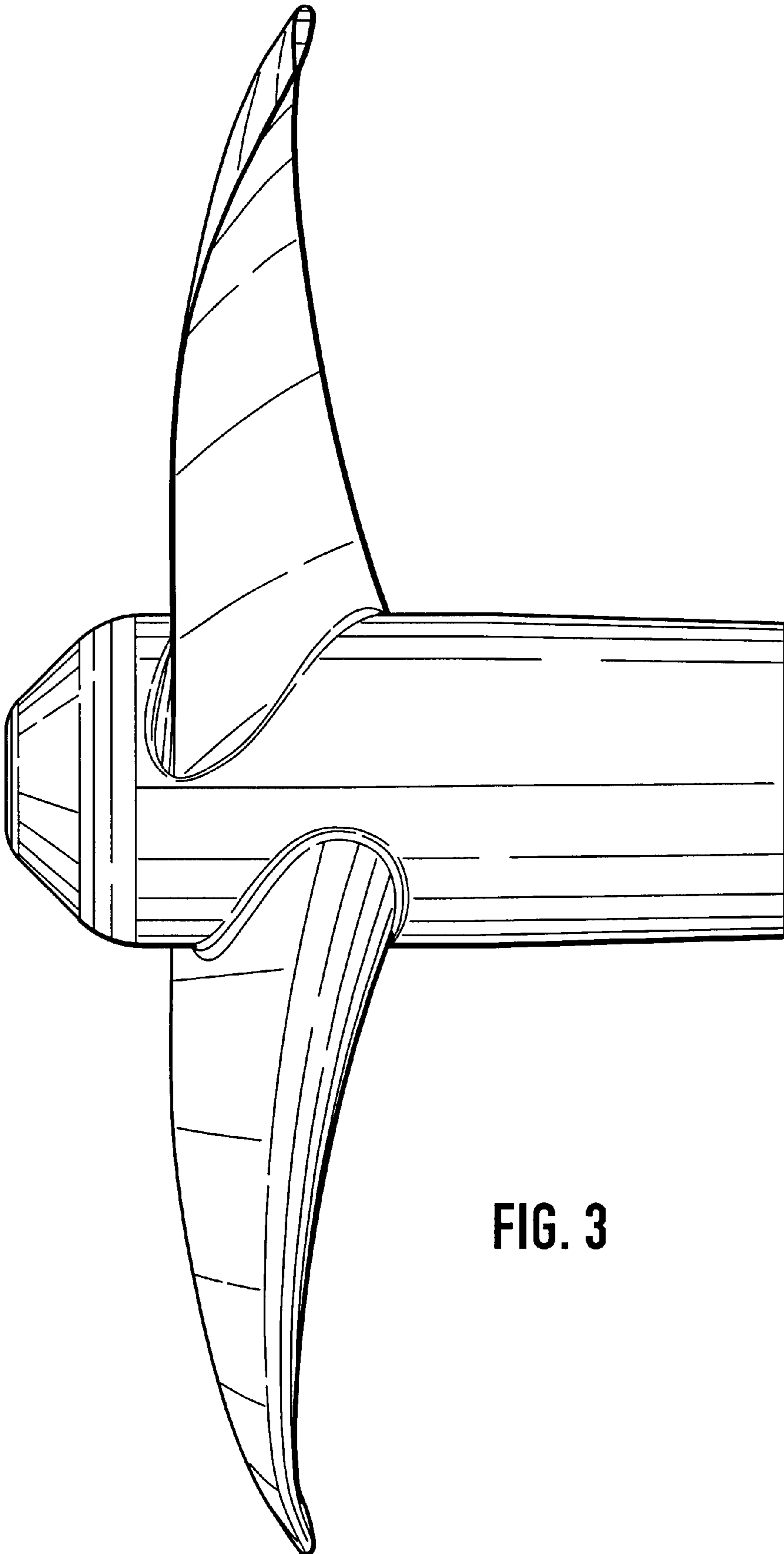

FIG. 3

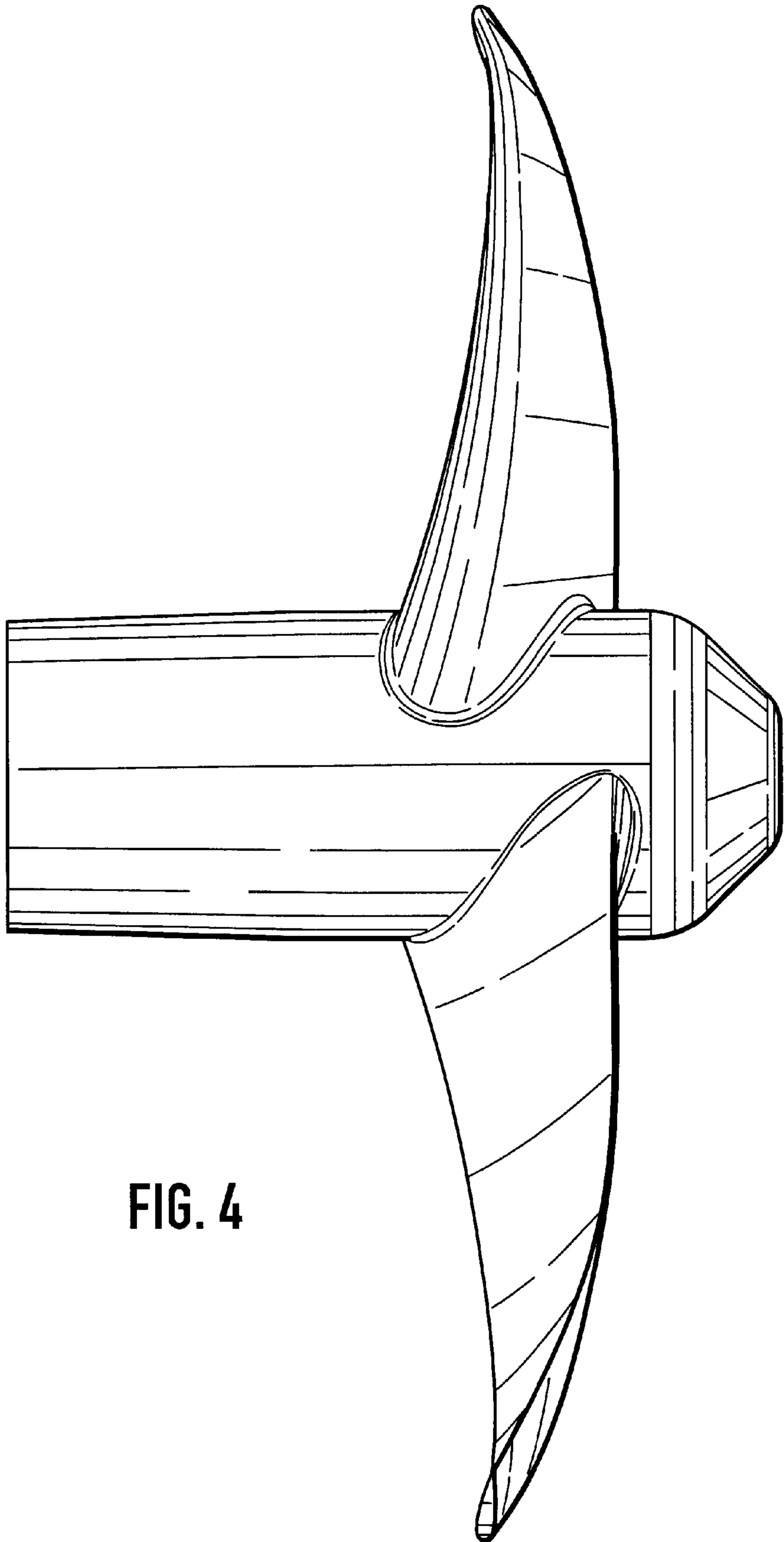

FIG. 4

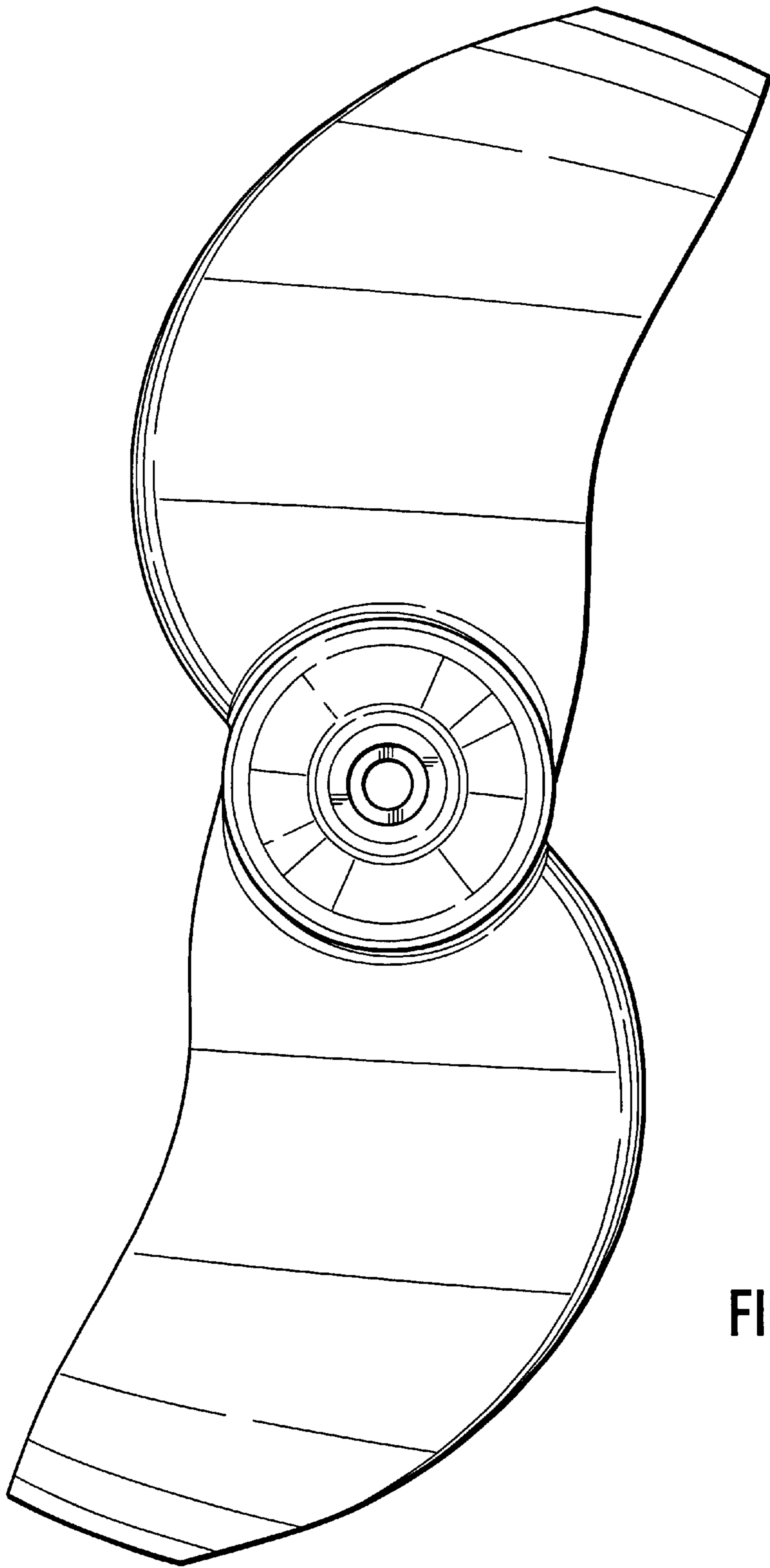

FIG. 5

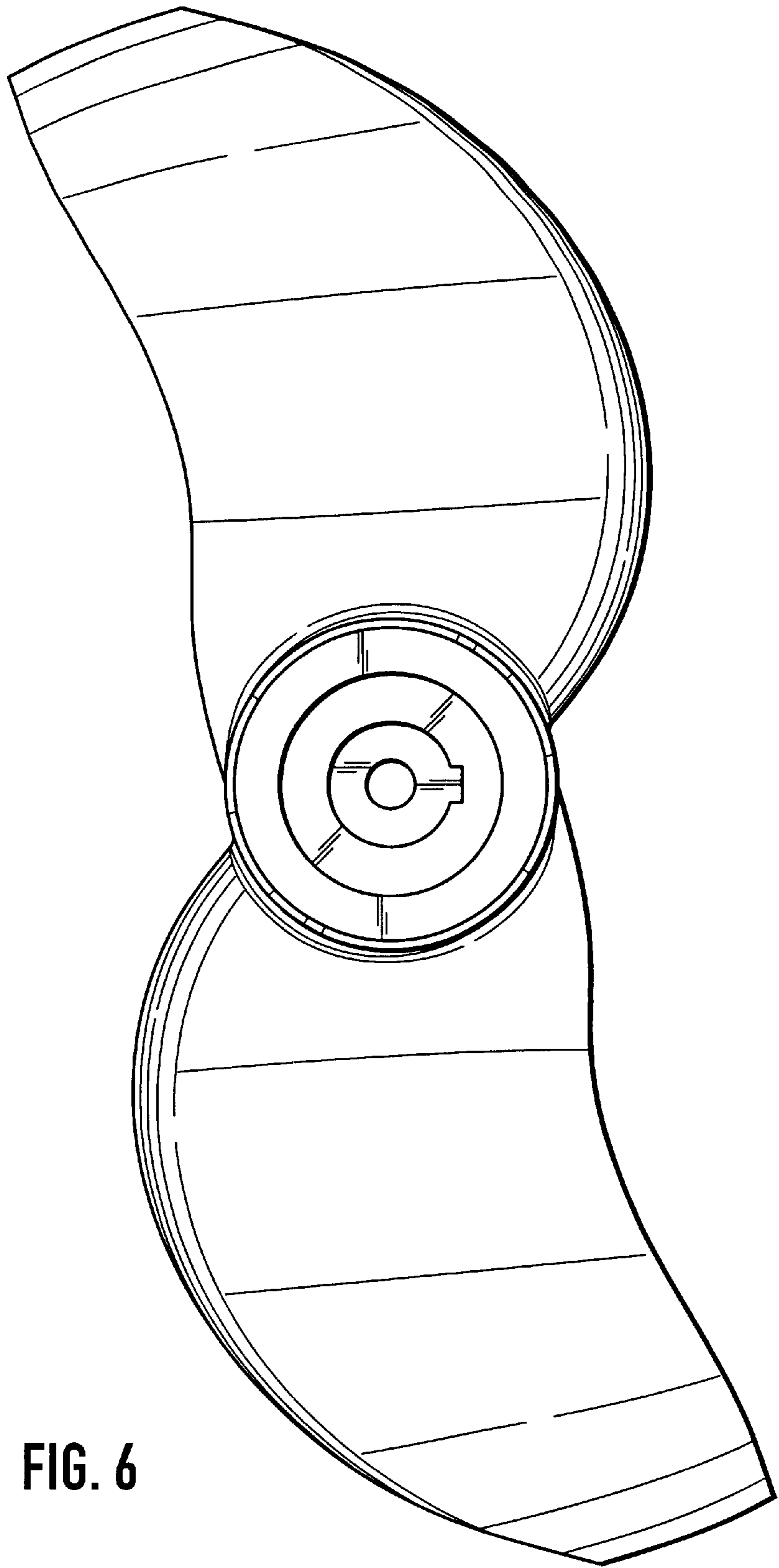

FIG. 6