



US00D457467S

(12) **United States Design Patent**
Shimizu

(10) **Patent No.:** **US D457,467 S**

(45) **Date of Patent:** **** May 21, 2002**

(54) **AUTOMOBILE**

(75) Inventor: **Hiroshi Shimizu**, Kamakura (JP)

(73) Assignee: **Japan Science and Technology**,
Saitama (JP)

(**) Term: **14 Years**

(21) Appl. No.: **29/146,259**

(22) Filed: **Aug. 8, 2001**

(30) **Foreign Application Priority Data**

Jun. 4, 2001 (JP) 2001-016179

(51) **LOC (7) Cl.** **12-08**

(52) **U.S. Cl.** **D12/86**

(58) **Field of Search** D12/86, 90-92;
296/185

(56) **References Cited**

U.S. PATENT DOCUMENTS

D373,330 S * 9/1996 Halajko D12/90

D397,961 S * 9/1998 Mays et al. D12/91

D434,346 S * 1/2000 Pfeiffer D12/92

D449,019 S * 10/2001 Simpson et al. D12/92

* cited by examiner

Primary Examiner—Melody N. Brown

(74) *Attorney, Agent, or Firm*—Sughrue Mion, PLLC

(57) **CLAIM**

The ornamental design for an automobile, as shown and described.

DESCRIPTION

FIG. 1 is a front perspective view of an automobile showing my new design;

FIG. 2 is a rear perspective view thereof;

FIG. 3 is a front view thereof;

FIG. 4 is a rear view thereof;

FIG. 5 is a right side view thereof, the left side being a mirror image; and,

FIG. 6 is a top plan view thereof.

1 Claim, 5 Drawing Sheets

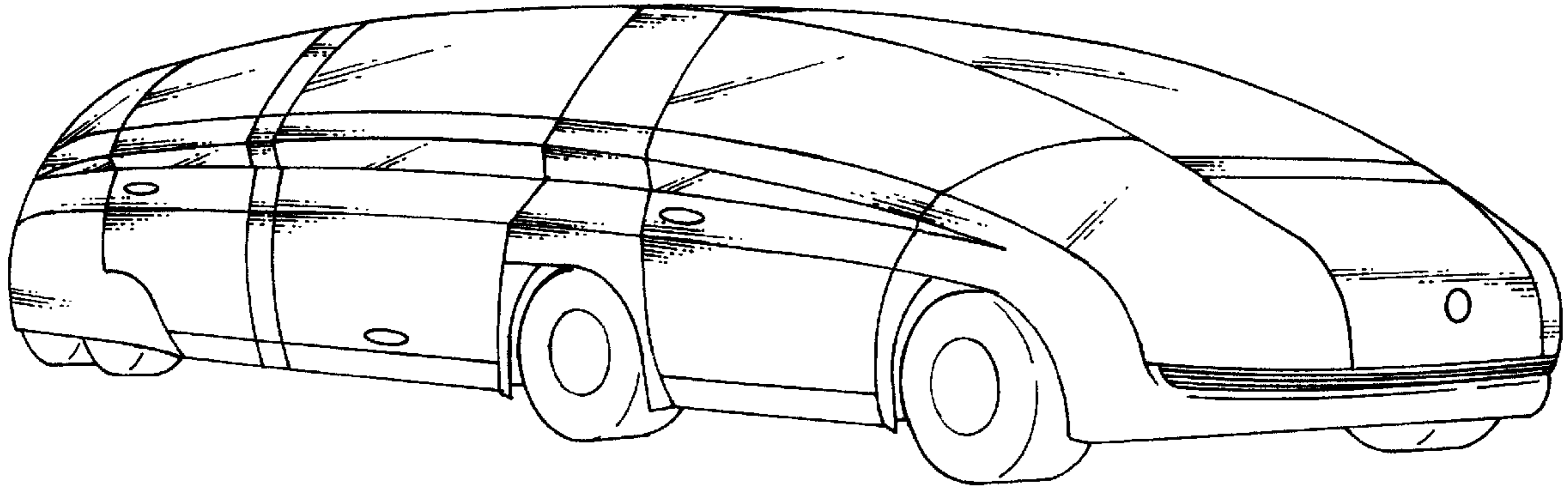

FIG. 1

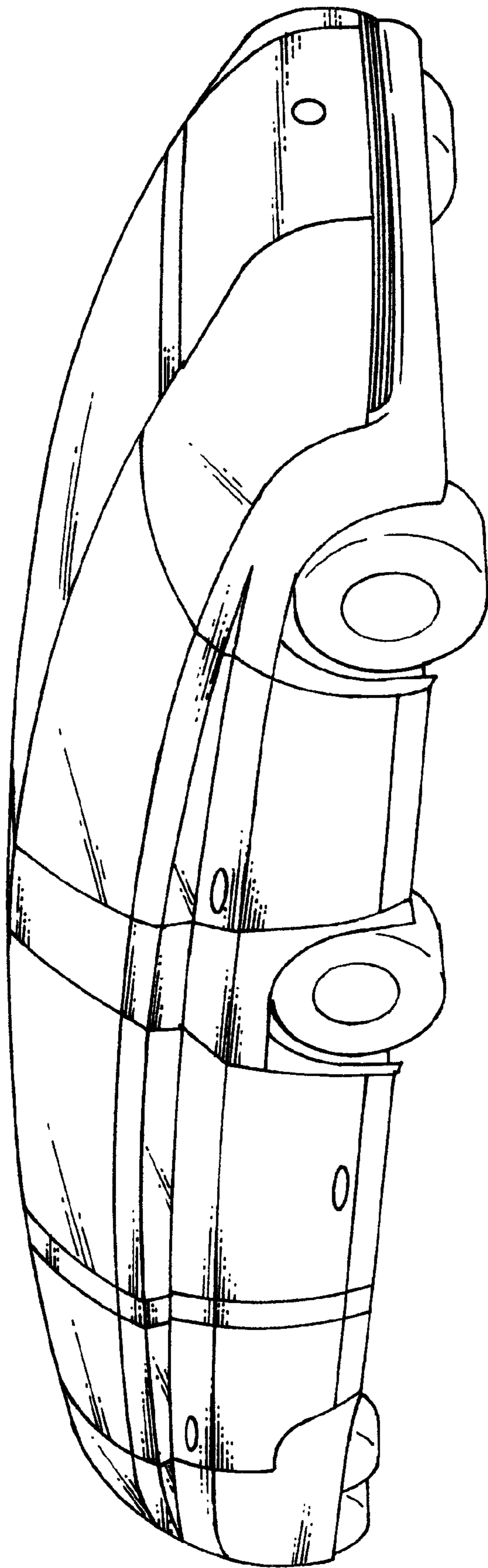

FIG. 2

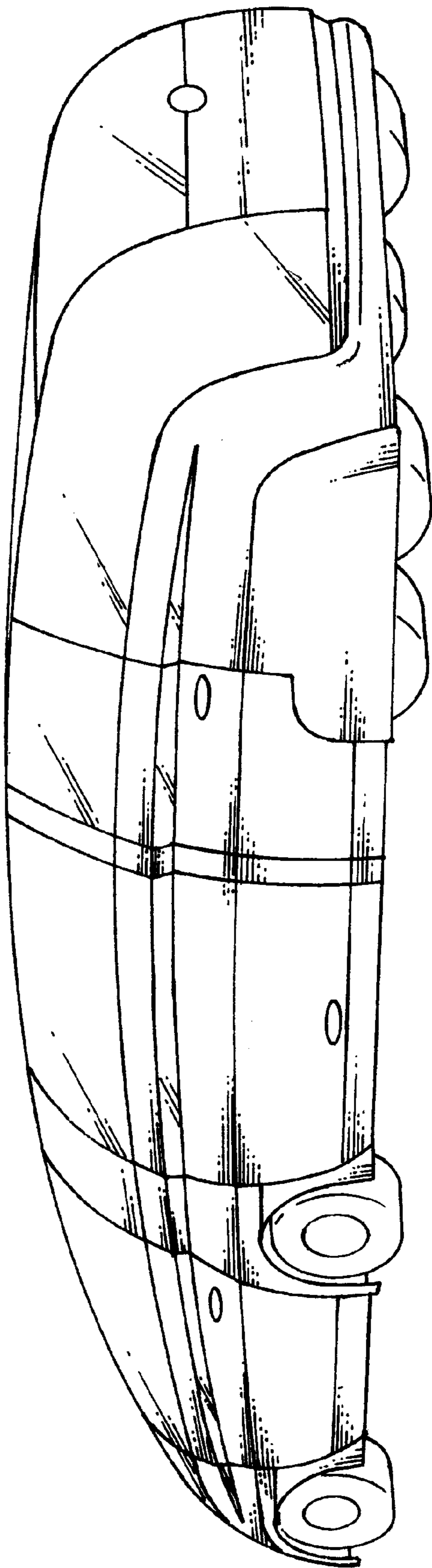

FIG. 3

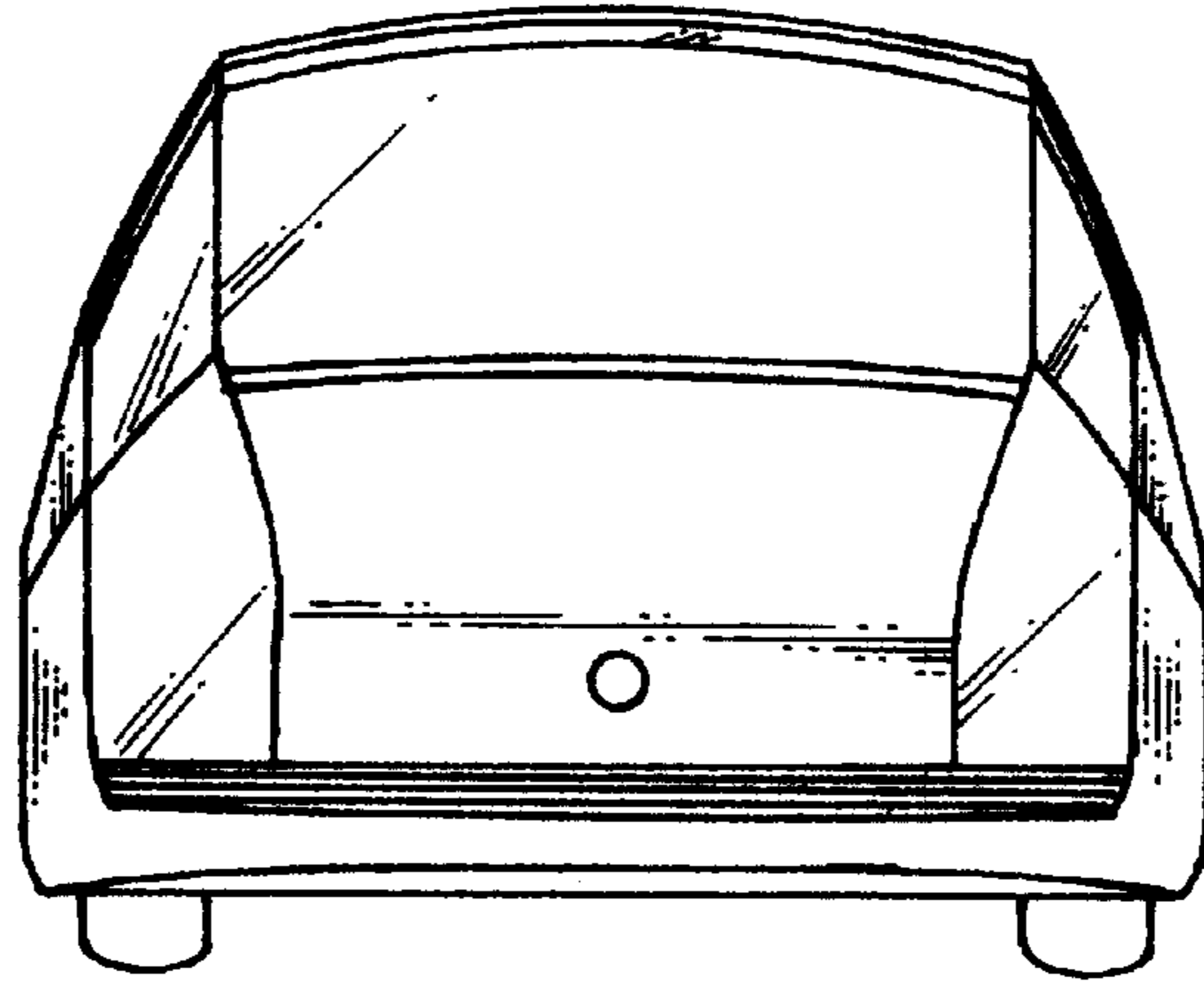

FIG. 4

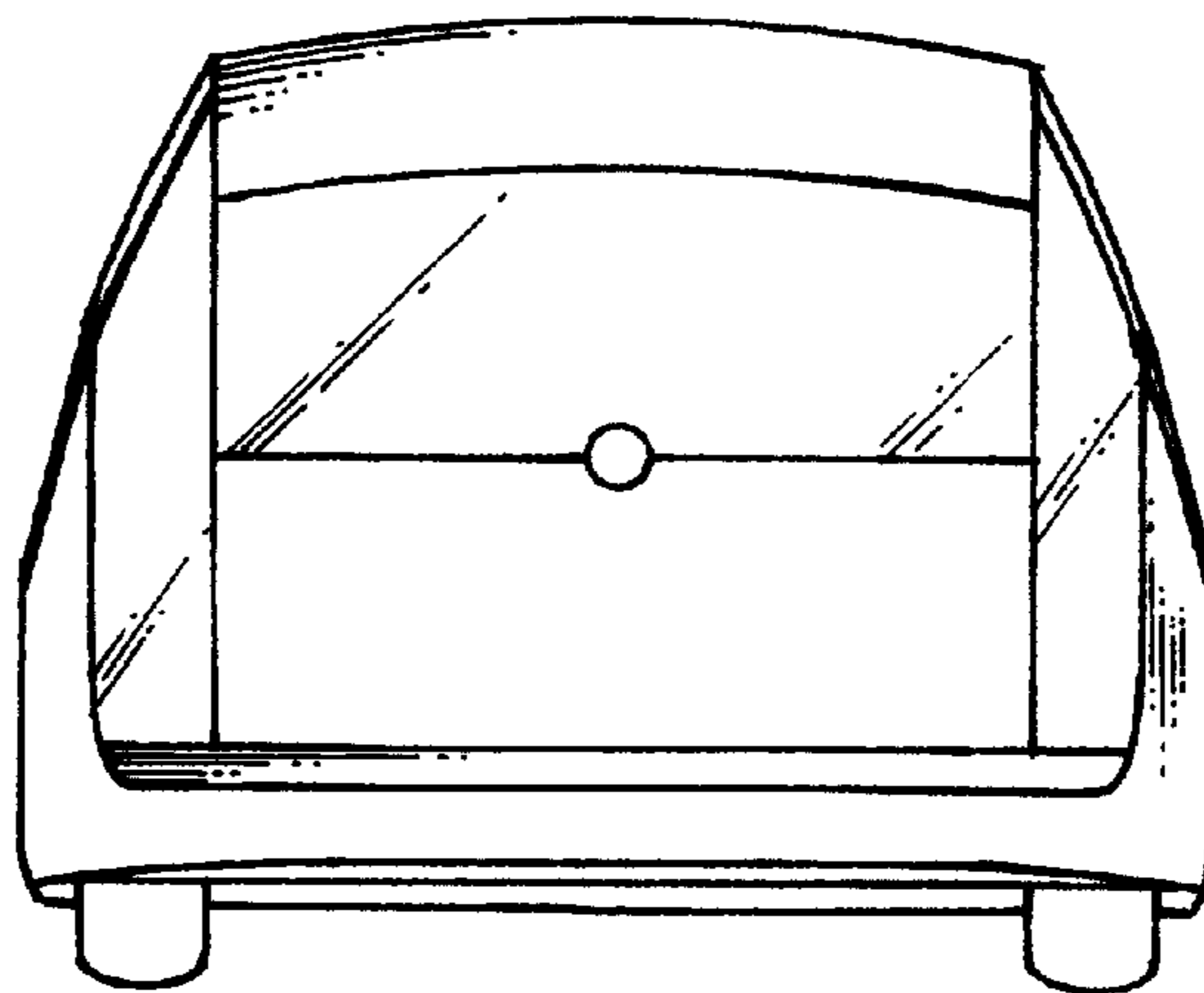

FIG. 5

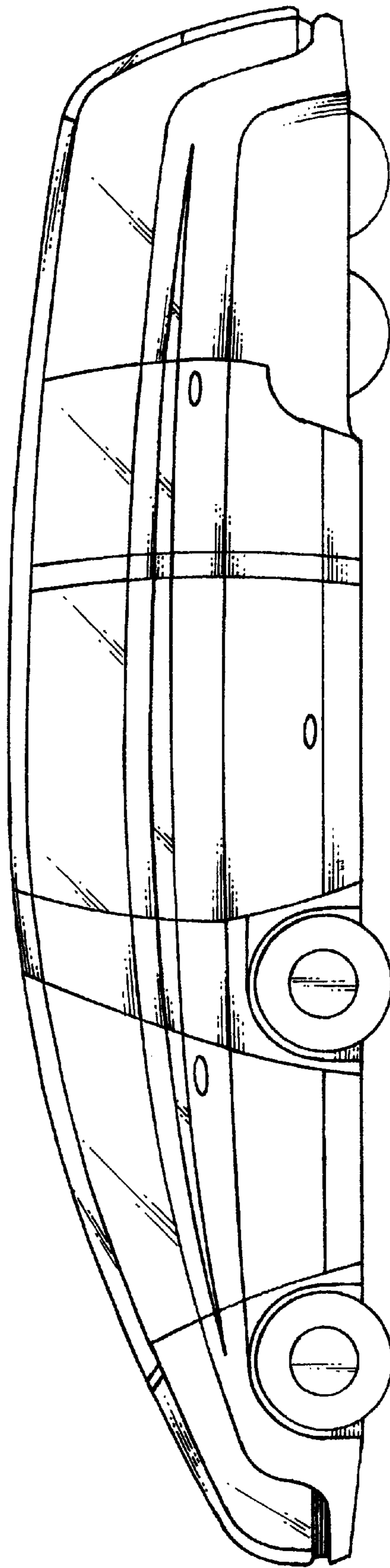

FIG. 6

