



US00D457370S

(12) **United States Design Patent**
Martinez

(10) **Patent No.:** **US D457,370 S**

(45) **Date of Patent:** **** May 21, 2002**

(54) **GOLF CADDIE**

(76) **Inventor:** **Robert Martinez**, P.O. Box 66,
McCordsville, IN (US) 46055

(**) **Term:** **14 Years**

(21) **Appl. No.:** **29/144,131**

(22) **Filed:** **Jun. 26, 2001**

(51) **LOC (7) Cl.** **08-08**

(52) **U.S. Cl.** **D6/552; D21/796**

(58) **Field of Search** **D6/552, 396, 409,**
D6/410, 417; D21/759, 796; 473/282, 287,
409; 206/315.2, 315.7; 248/688

(56) **References Cited**

U.S. PATENT DOCUMENTS

2,737,990 A	3/1956	De Marco	
2,987,109 A	6/1961	Sohmer	
2,990,865 A	7/1961	Steele	
3,058,504 A	10/1962	Powers	
3,215,181 A	11/1965	Reed	
5,226,666 A	7/1993	Dinkens, Jr.	
D346,081 S	* 4/1994	Turner	D6/410 X
D360,248 S	* 7/1995	Wright	D21/796
D372,141 S	7/1996	Selby	
D372,142 S	7/1996	Selby	

D372,144 S	7/1996	Selby	
5,873,471 A	* 2/1999	Ruggeri	248/688 X
D407,774 S	* 4/1999	Weiss	D21/796
D447,530 S	* 9/2001	Hidalgo	D21/796

* cited by examiner

Primary Examiner—Brian N. Vinson
(74) *Attorney, Agent, or Firm*—Brinks Hofer Gilson & Lione

(57) **CLAIM**

I claim the ornamental design for a golf caddie, as shown and described.

DESCRIPTION

FIG. 1 is a front elevational view of a golf caddie showing my new design, the broken-line disclosure understood to be for illustrative purposes only and forming no part of the claimed design;

FIG. 2 is a bottom plan view thereof;

FIG. 3 is a top plan view thereof;

FIG. 4 is a rear elevational view thereof;

FIG. 5 is a left side elevational view thereof;

FIG. 6 is a right side elevational view thereof; and,

FIG. 7 is a fragmentary, vertical cross-sectional view thereof, taken along line 7—7 of FIG. 1.

1 Claim, 2 Drawing Sheets

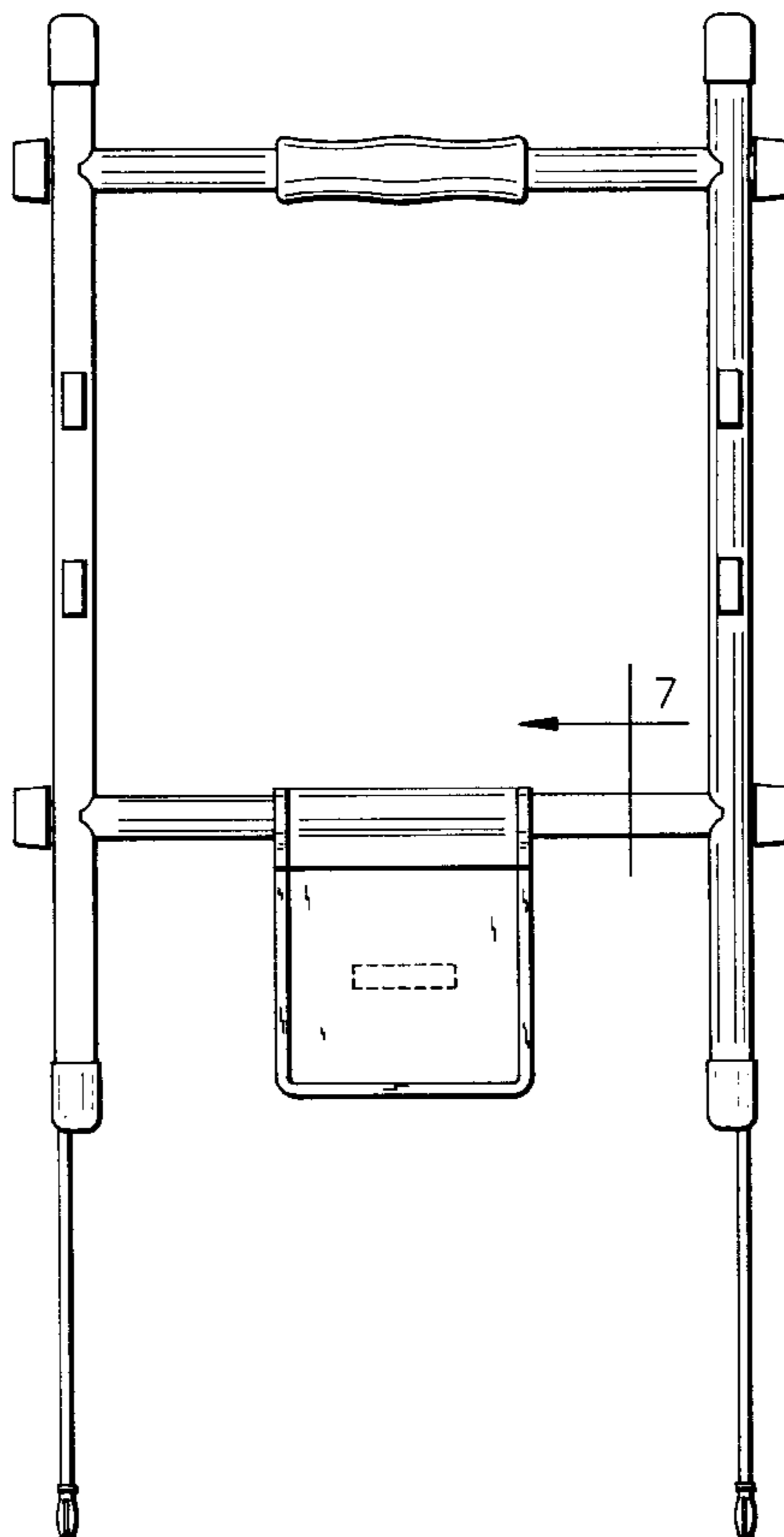



FIG. 3

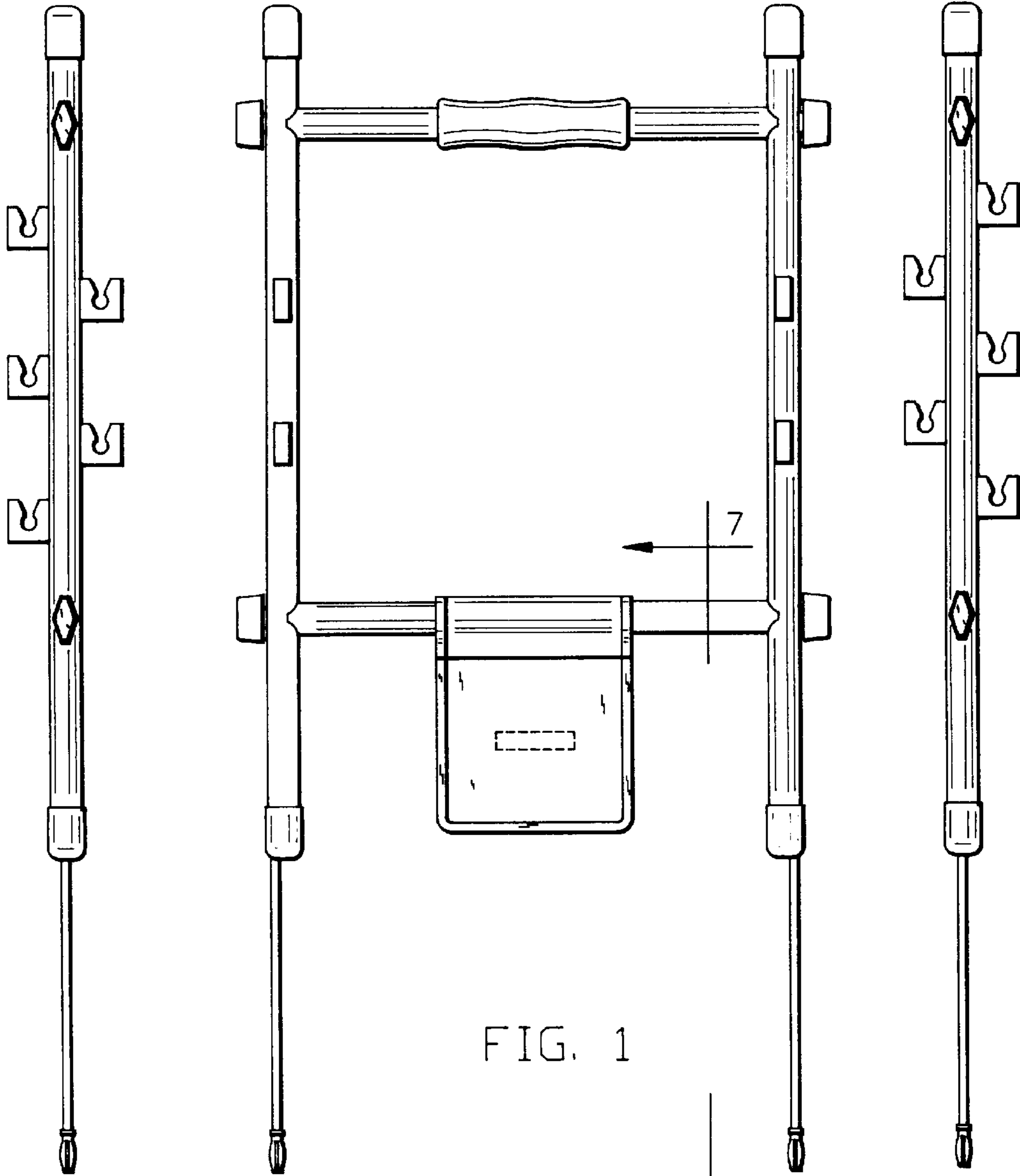

FIG. 1

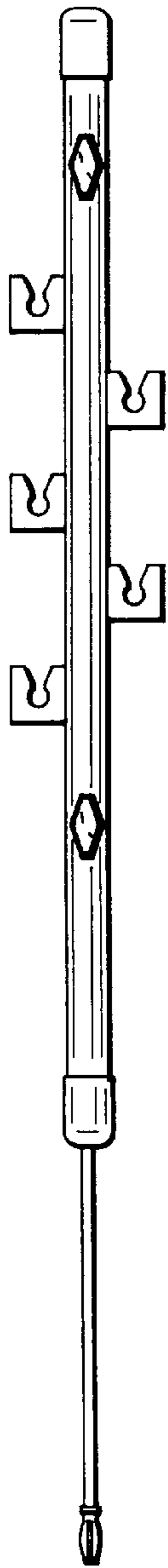

FIG. 5

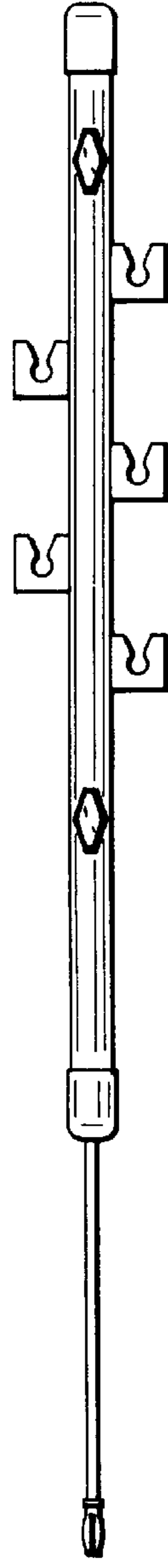

FIG. 6

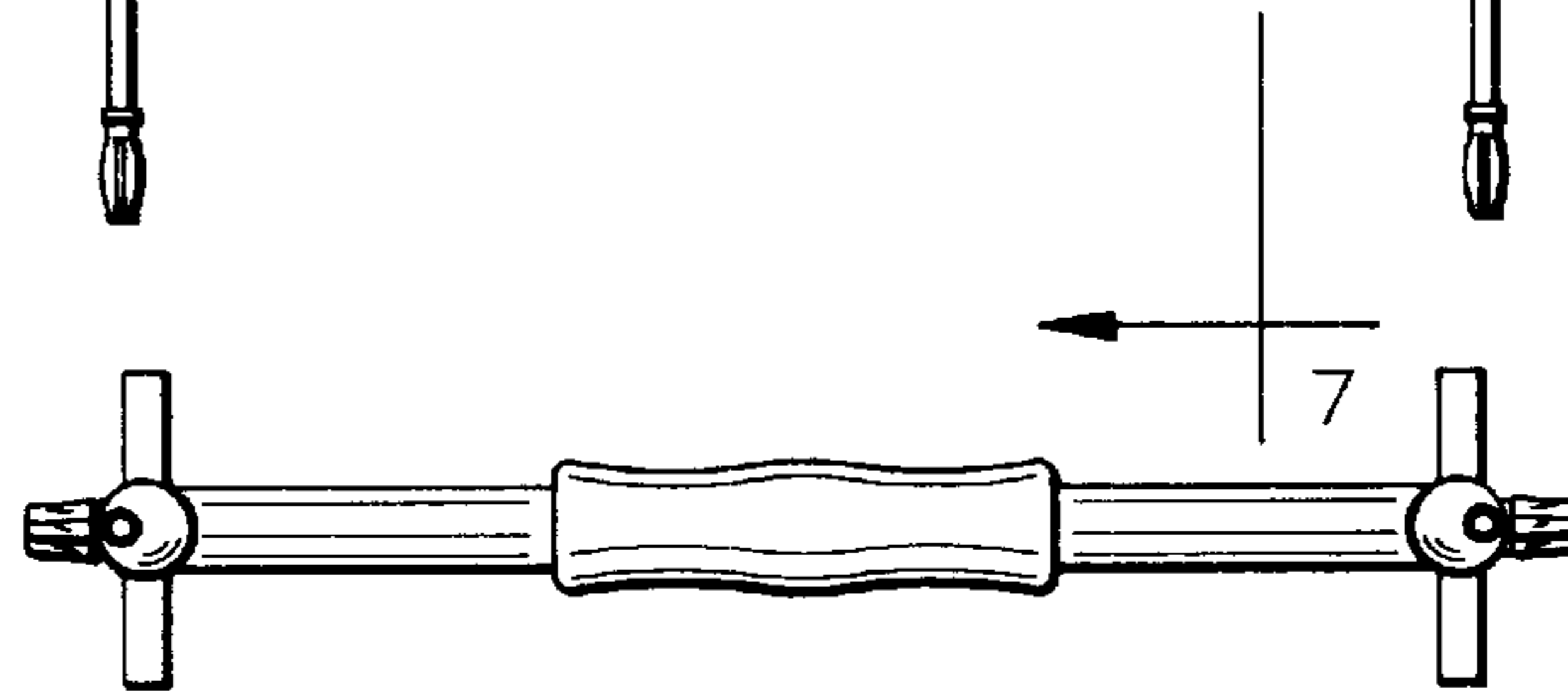

FIG. 2

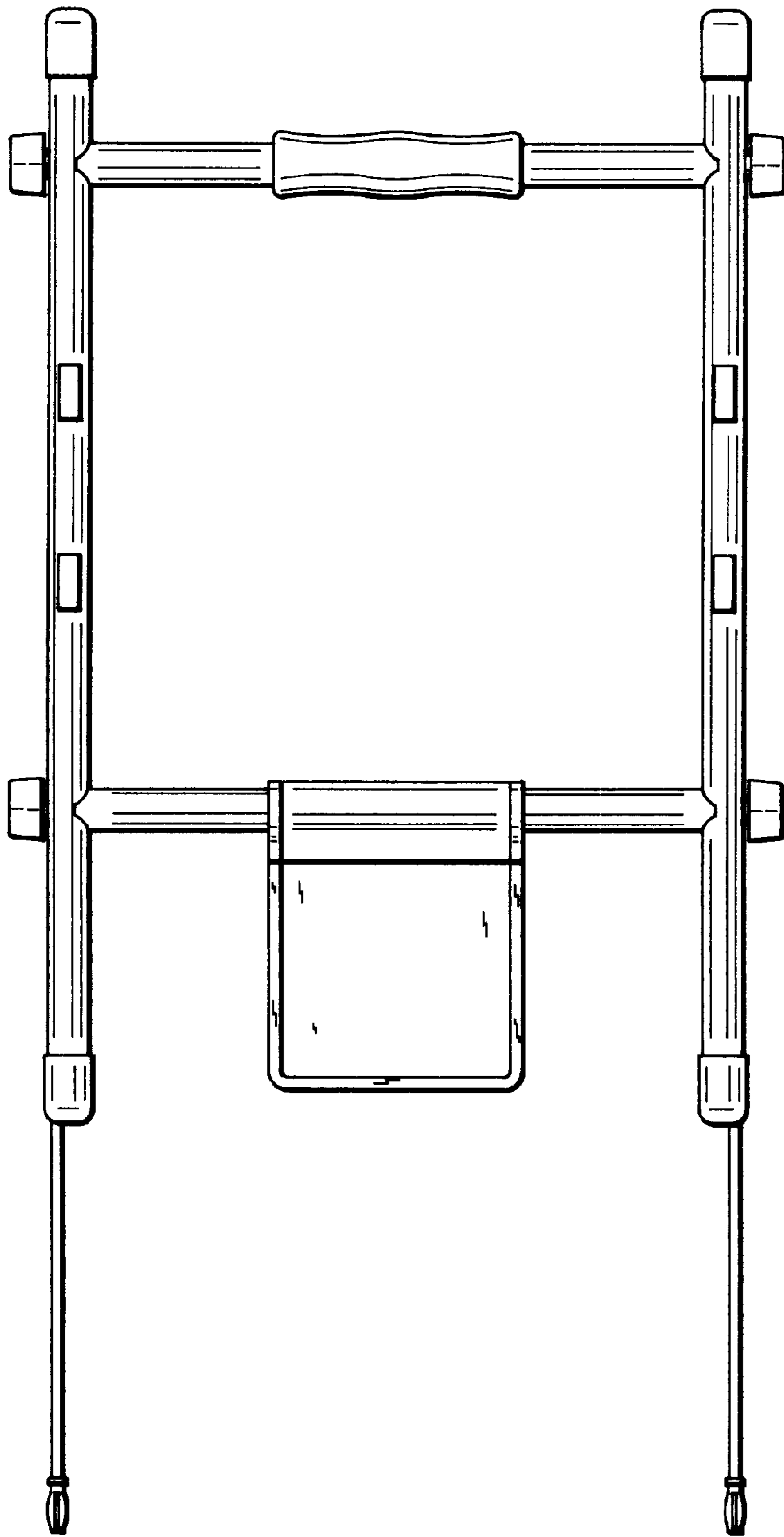

FIG. 4

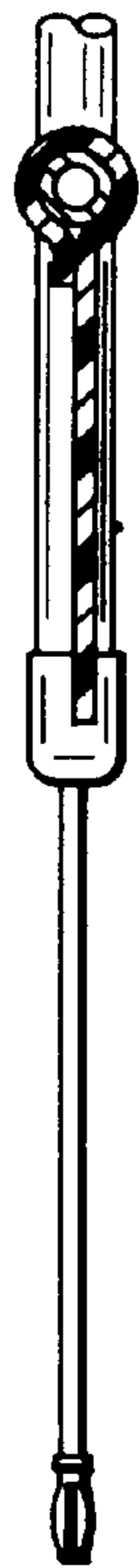

FIG. 7