



US00D457107S

(12) **United States Design Patent**
Kember et al.

(10) **Patent No.:** **US D457,107 S**

(45) **Date of Patent:** **** May 14, 2002**

(54) **AUTOMOBILE**

Isuzu Kai, Motor Fun, Nov. 23, 1999, p. 118 and 119.

(75) Inventors: **Craig Kember**, Irvine; **Kevin K. Hunter**, Laguna Niguel, both of CA (US)

* cited by examiner

(73) Assignee: **Toyota Jidosha Kabushiki Kaisha (JP)**

Primary Examiner—Melody N. Brown
(74) *Attorney, Agent, or Firm*—SAIDMAN DesignLaw Group

(**) Term: **14 Years**

(57) **CLAIM**

(21) Appl. No.: **29/145,430**

The ornamental design for an automobile, as shown and described.

(22) Filed: **Jul. 23, 2001**

(51) **LOC (7) Cl.** **12-08**

(52) **U.S. Cl.** **D12/91**

(58) **Field of Search** D12/90-92, 86;
296/185

DESCRIPTION

(56) **References Cited**

U.S. PATENT DOCUMENTS

- D431,209 S * 9/2000 O'Connell D12/92
- D439,204 S * 3/2001 Odette et al. D12/92
- D440,526 S * 4/2001 Dehner et al. D12/92
- D449,019 S * 10/2001 Simpson et al. D12/92

- FIG. 1 is a front perspective view of an automobile showing our new design;
- FIG. 2 is a rear perspective view thereof;
- FIG. 3 is a front view thereof;
- FIG. 4 is a rear view thereof;
- FIG. 5 is a right side view thereof; the left side being a mirror image,
- FIG. 6 is a top view thereof; and,
- FIG. 7 is a bottom view thereof.

OTHER PUBLICATIONS

- Kia KMS-4, Motor Fun, Dec. 6, 1997, p. 46.
- Nissan Trail Runner, Motor Magazine, Nov. 15, 1997.
- Nissan Cypact, Motor Fun, Nov. 23, 1999, p. 18 and 19.

The broken lines in the figures are shown for environmental purposes only and form no part of the claimed design.

1 Claim, 7 Drawing Sheets

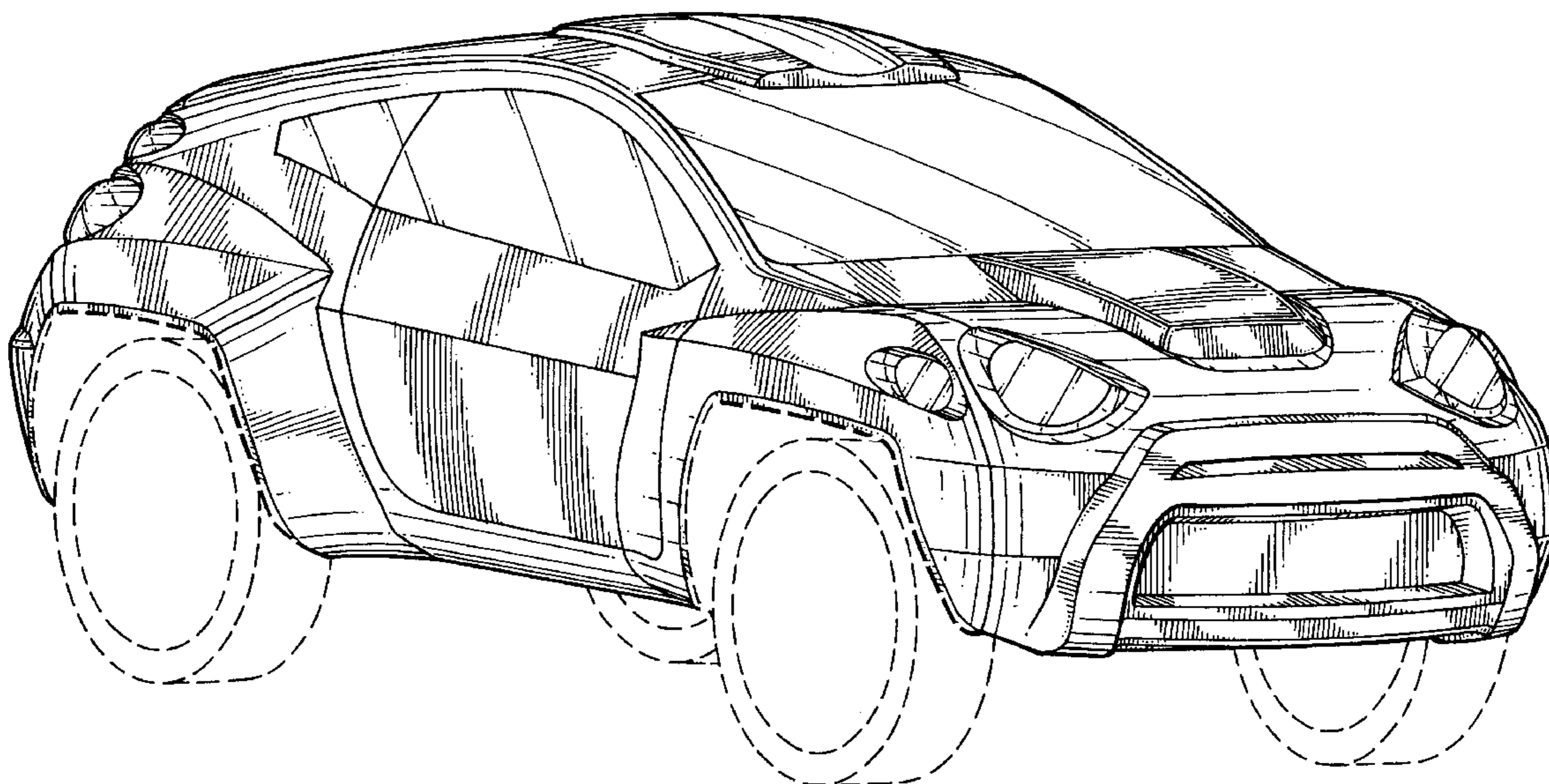

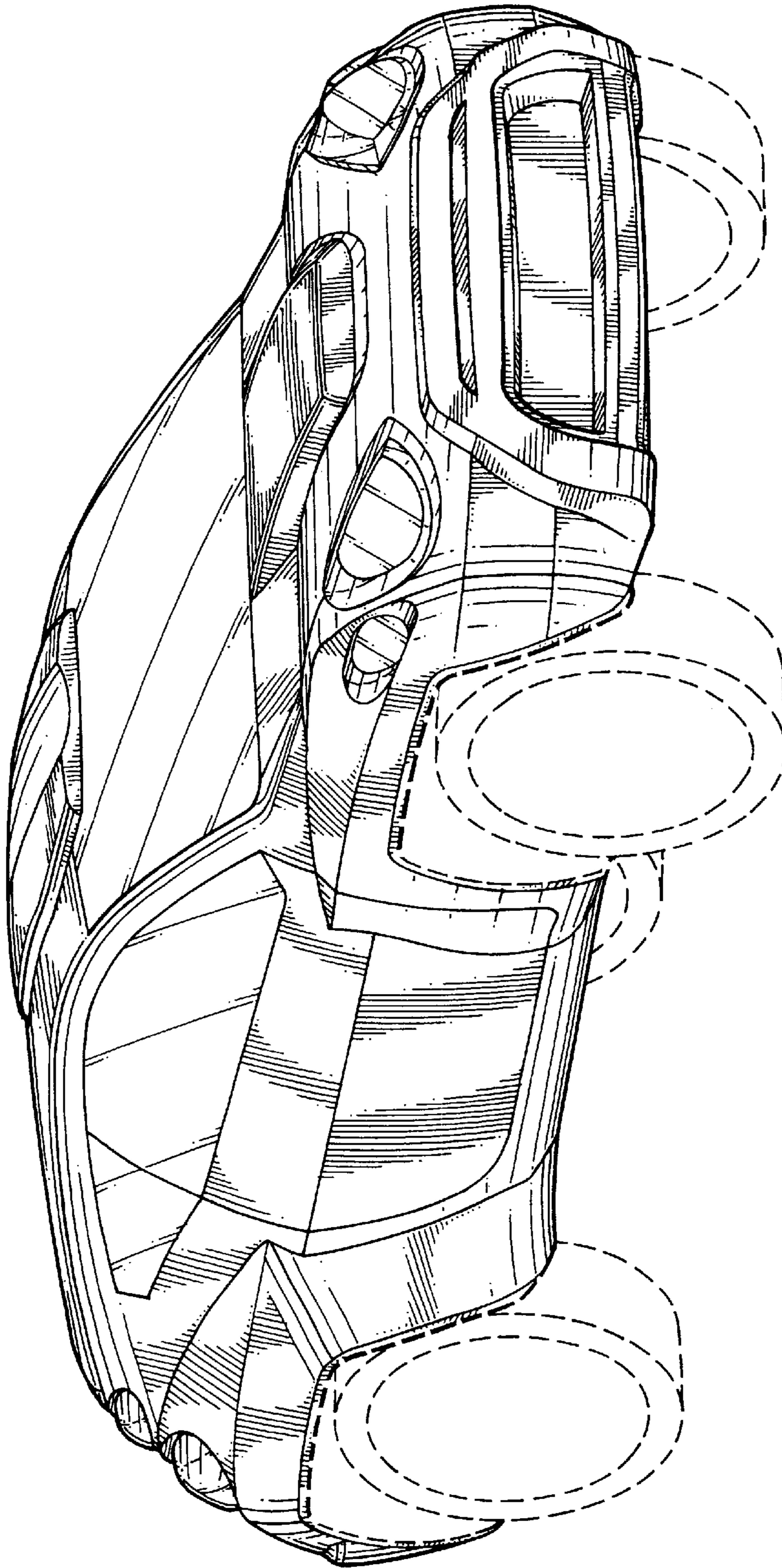

FIG.1

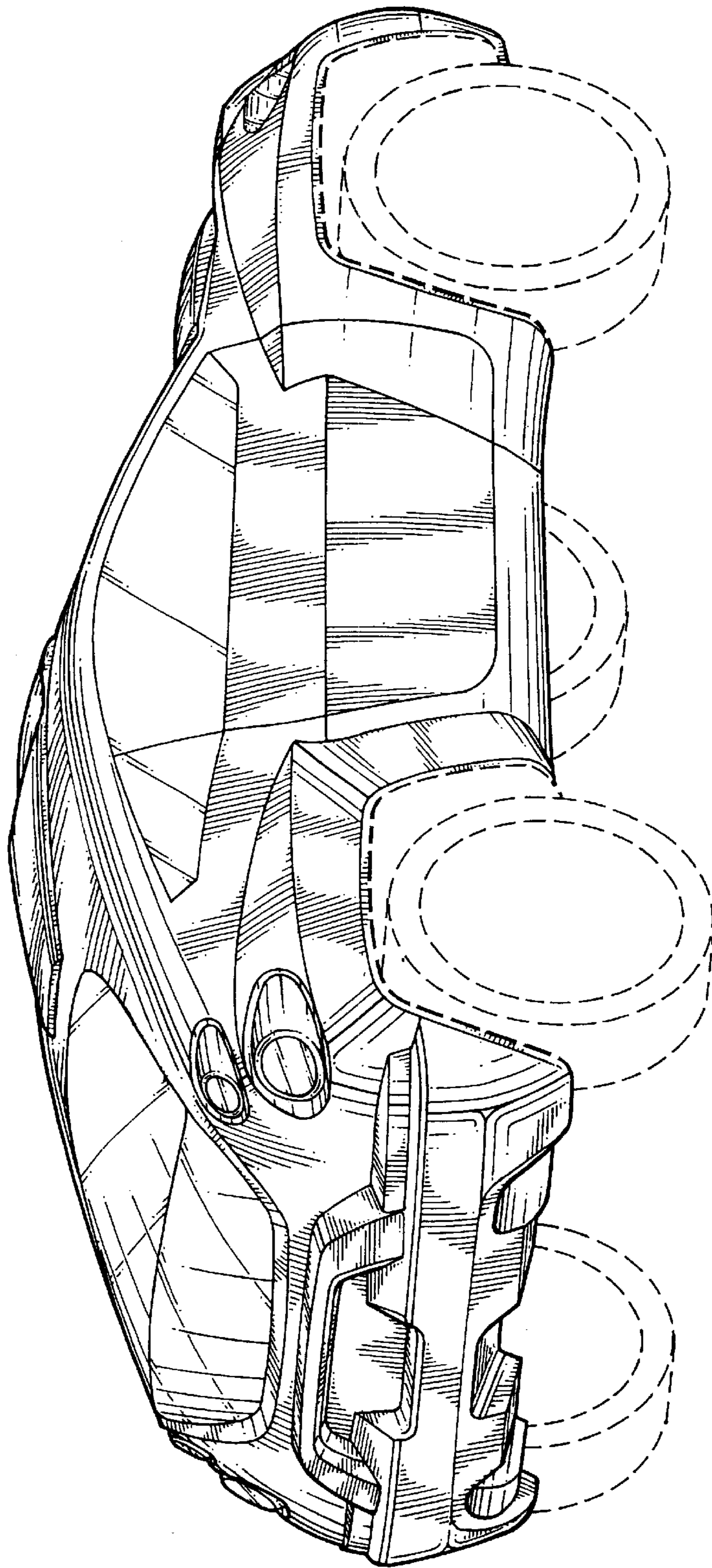

FIG.2

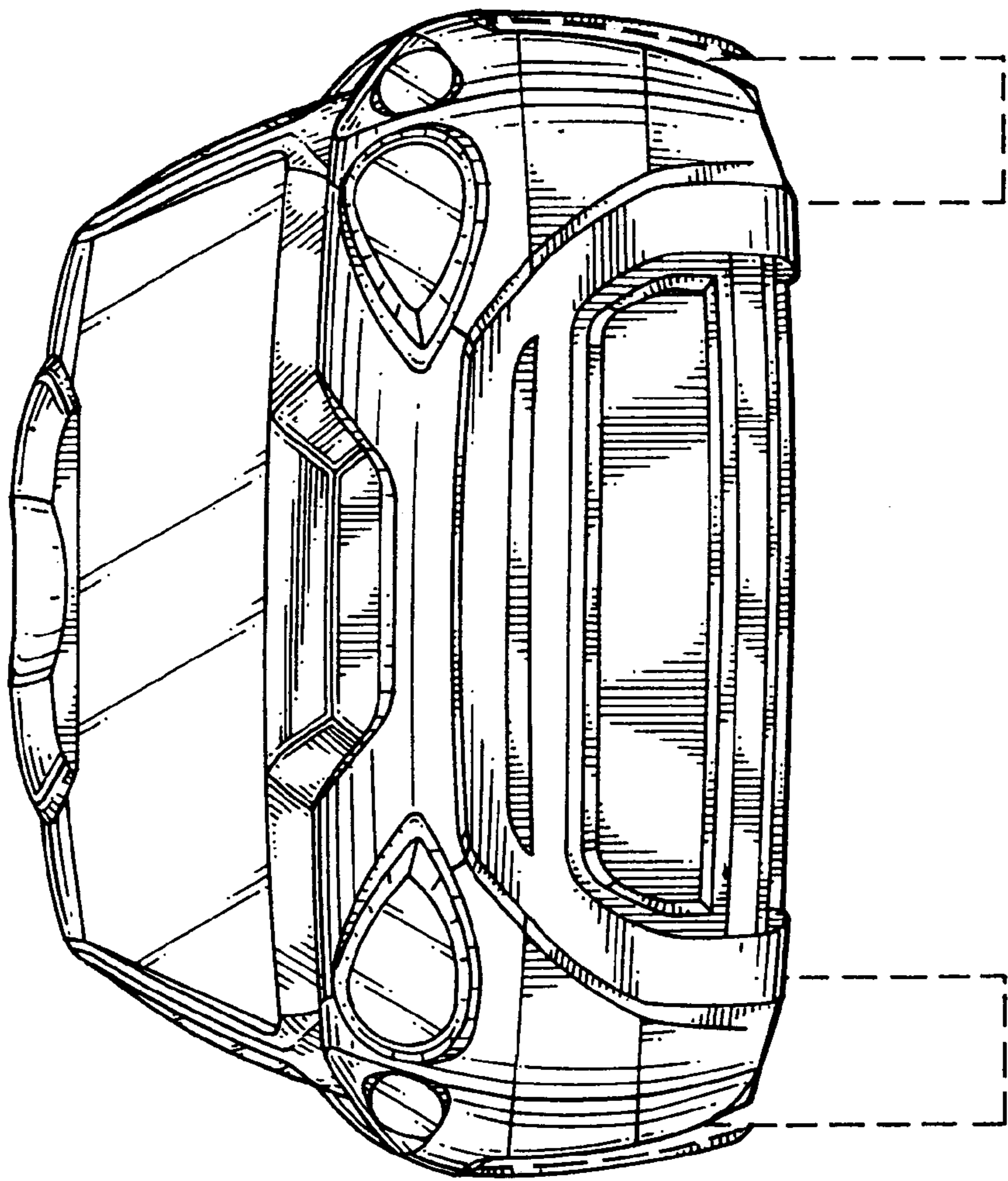

FIG.3

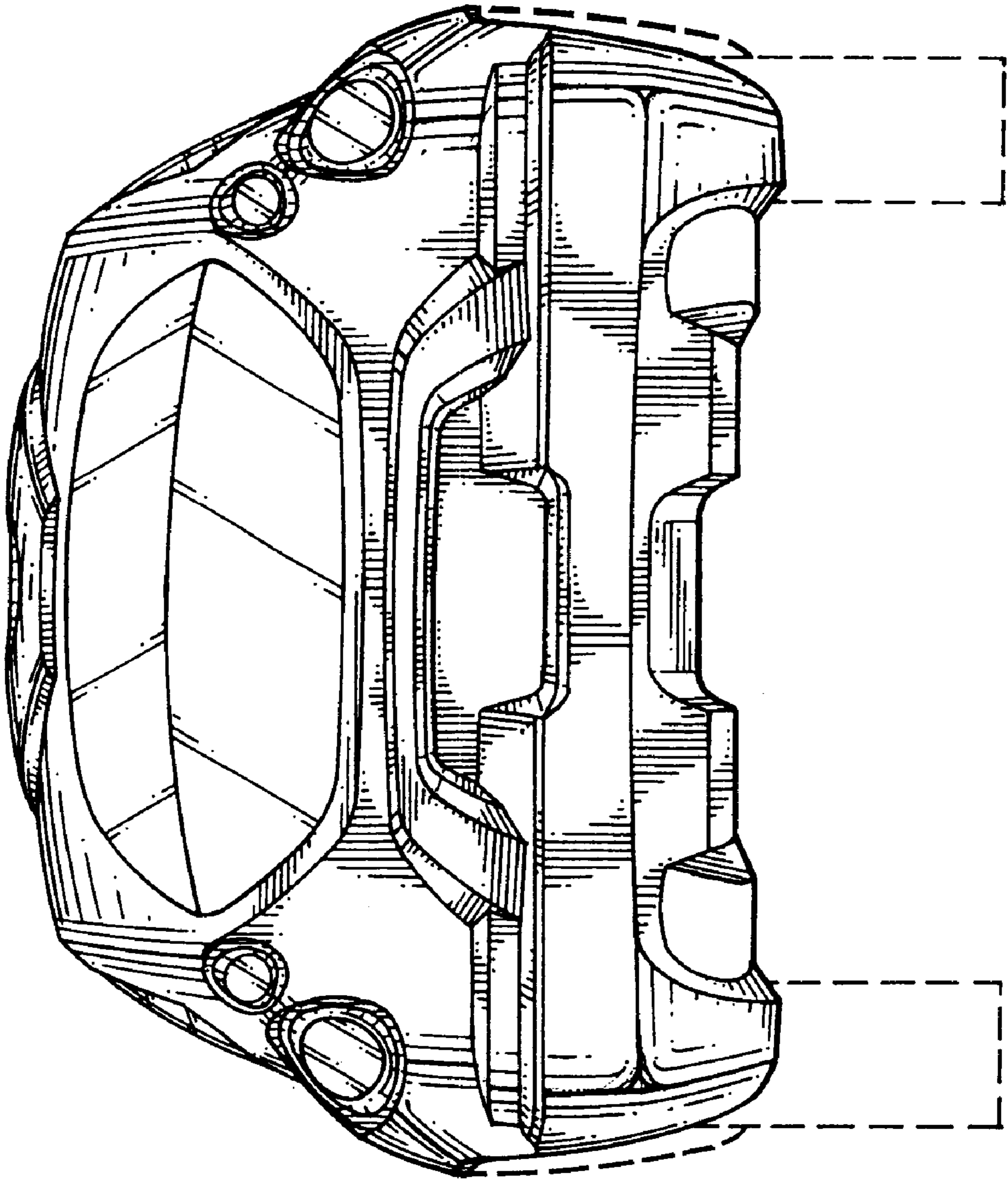

FIG.4

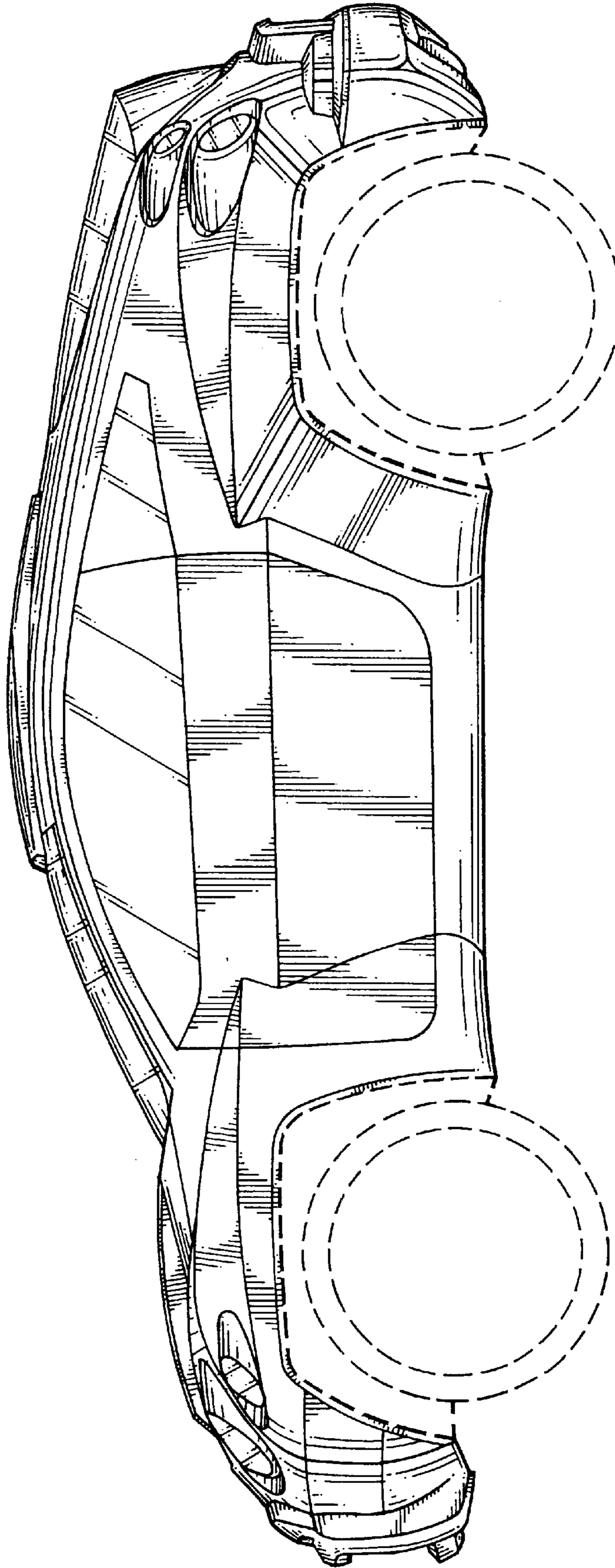

FIG.5

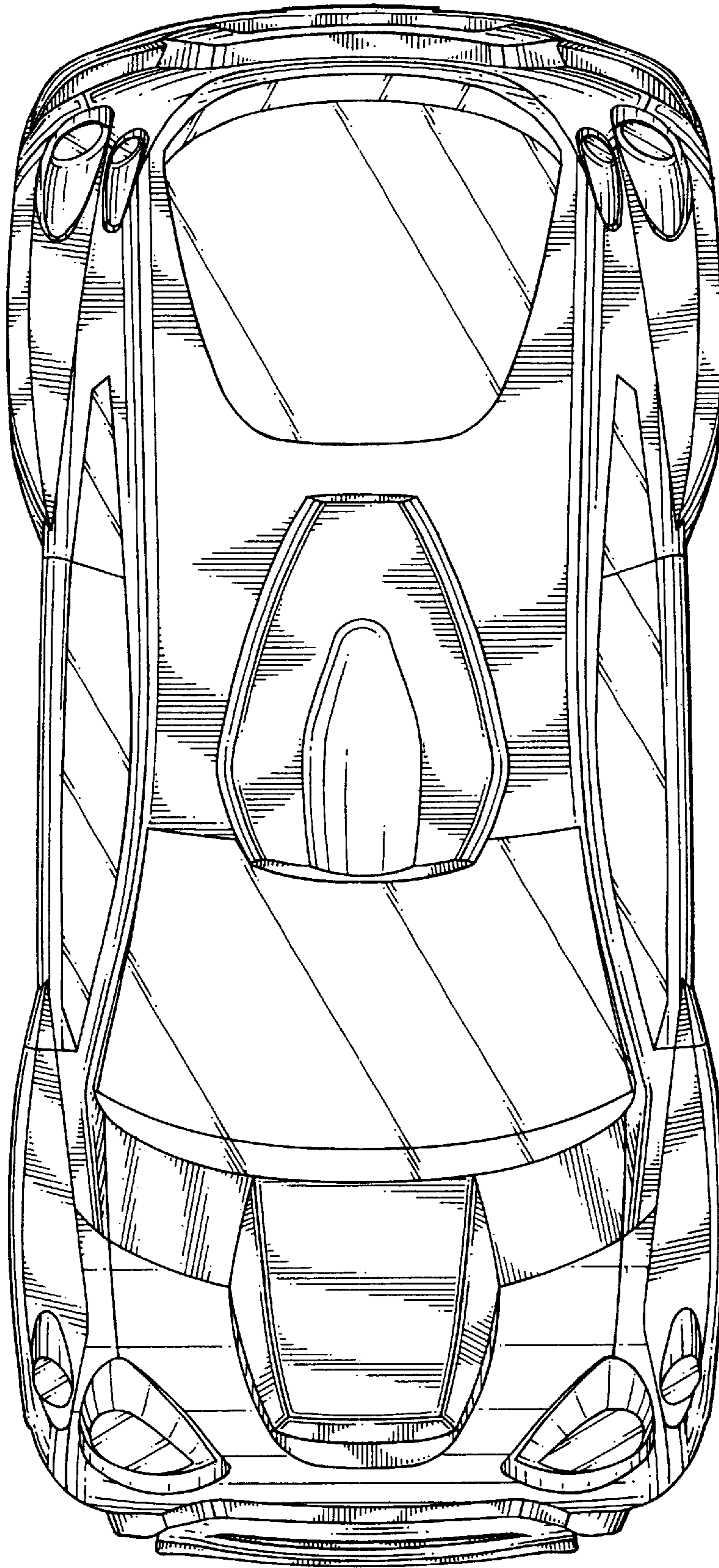

FIG.6

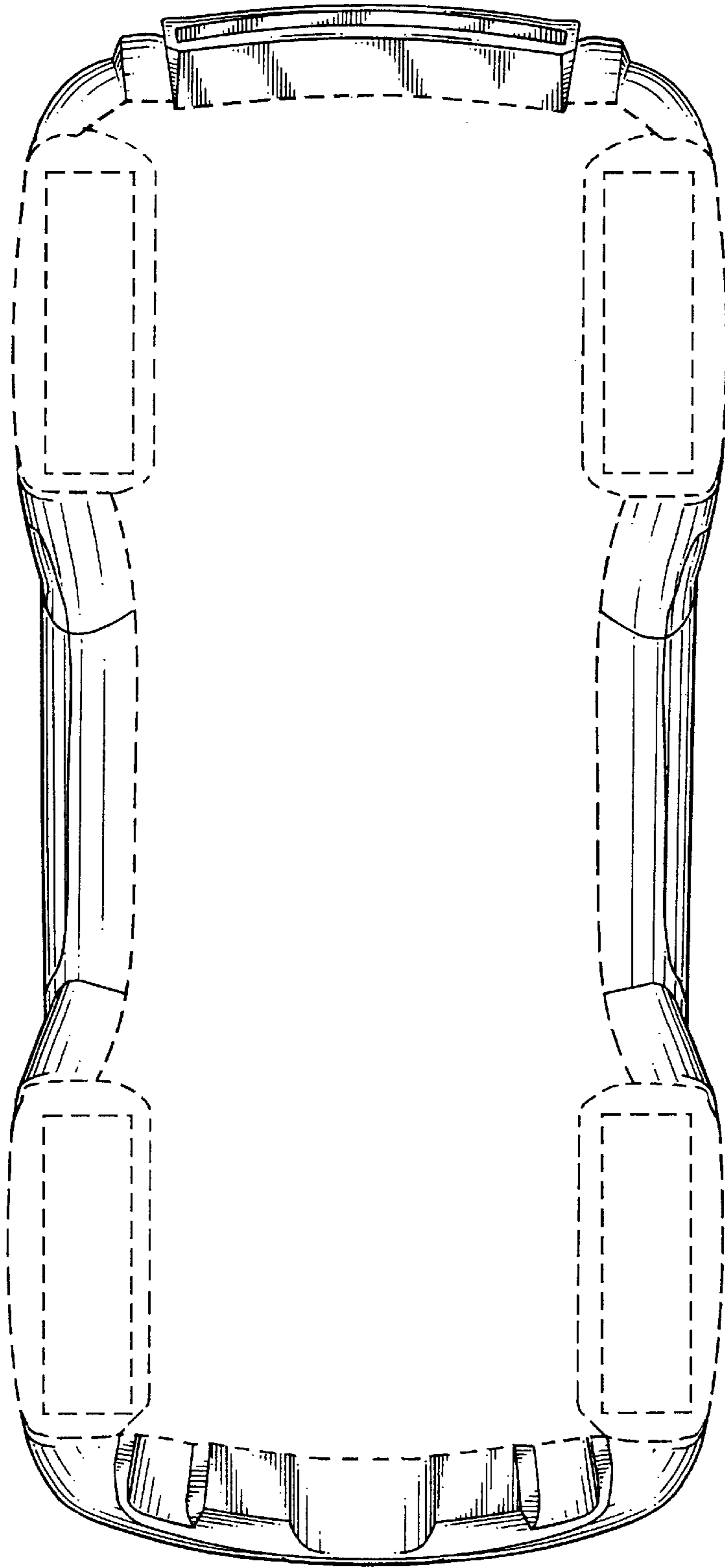

FIG.7