



US00D457091S

(12) **United States Design Patent** (10) **Patent No.:** **US D457,091 S**
Lai (45) **Date of Patent:** **** May 14, 2002**

(54) **JEWELRY SETTING**

(75) Inventor: **Danny S. Lai**, New York, NY (US)

(73) Assignee: **Gramercy Jewelry Manufacturing Corp.**, New York, NY (US)

(**) Term: **14 Years**

(21) Appl. No.: **29/143,255**

(22) Filed: **Jun. 11, 2001**

Related U.S. Application Data

(62) Division of application No. 29/127,597, filed on Aug. 7, 2000, now Pat. No. Des. 443,552.

(51) **LOC (7) Cl.** **11-01**

(52) **U.S. Cl.** **D11/91**

(58) **Field of Search** D11/1, 2, 7, 8, D11/26-27, 30-34, 36, 40, 48, 75, 79, 86, 89-92; 63/26-28, 29.1, 32, 12-15, 3, 4

(56) **References Cited**

U.S. PATENT DOCUMENTS

D114,649 S	5/1939	Simon
2,907,187 A	10/1959	Karp et al.
5,123,265 A	6/1992	Ramot
5,377,506 A	1/1995	Tranzer
5,520,017 A	5/1996	Vivat
D379,601 S	6/1997	Itzkowitz
D391,516 S	3/1998	Kothari

5,848,539 A	12/1998	Ouzounian
D403,611 S	1/1999	Lai
D411,134 S	6/1999	Lai
6,003,335 A	12/1999	Gurevich et al.
6,026,660 A	2/2000	Lai
D425,817 S	5/2000	Gurevich et al.
D427,934 S	6/2000	Lai
D430,061 S	* 8/2000	Chan D11/92
D432,448 S	* 10/2000	Lai D11/92

* cited by examiner

Primary Examiner—Louis S. Zarfaz

Assistant Examiner—Deanne Levy

(74) *Attorney, Agent, or Firm*—Baker Botts L.L.P.

(57) **CLAIM**

The ornamental design of a jewelry setting, as shown and described.

DESCRIPTION

FIG. 1 is a perspective view of a first embodiment of a jewelry setting of my new design; FIG. 2 is a top view of the jewelry setting shown in FIG. 1; FIG. 3 is a perspective view of a second embodiment of the jewelry setting of my new design; FIG. 4 is a top view of the jewelry setting shown in FIG. 3; FIG. 5 is a perspective view of a third embodiment of the jewelry setting of my new design; and, FIG. 6 is a top view of the jewelry setting shown in FIG. 5. The broken lines are provide for illustrative purposes only and form no part of the claimed design.

1 Claim, 3 Drawing Sheets

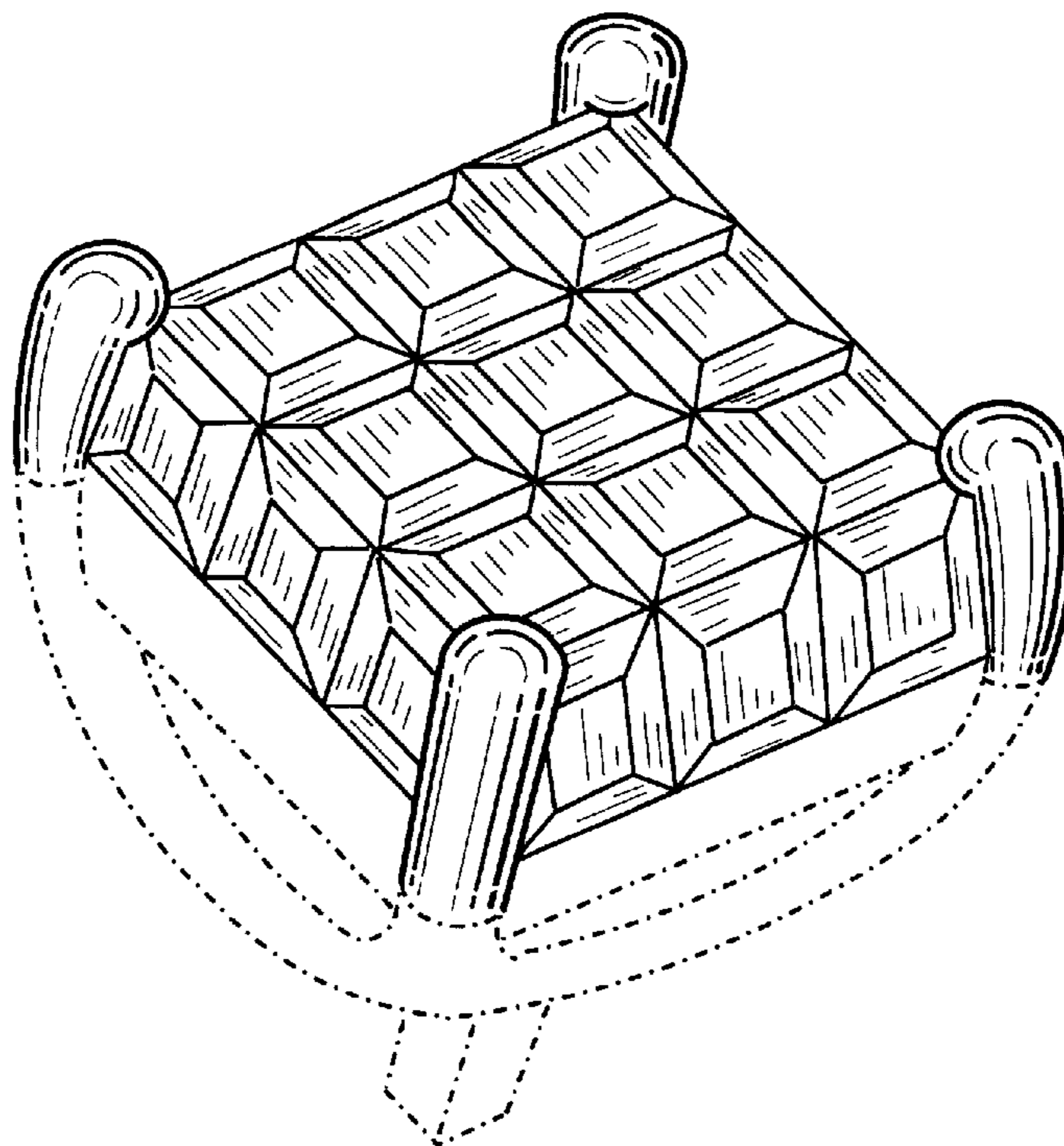

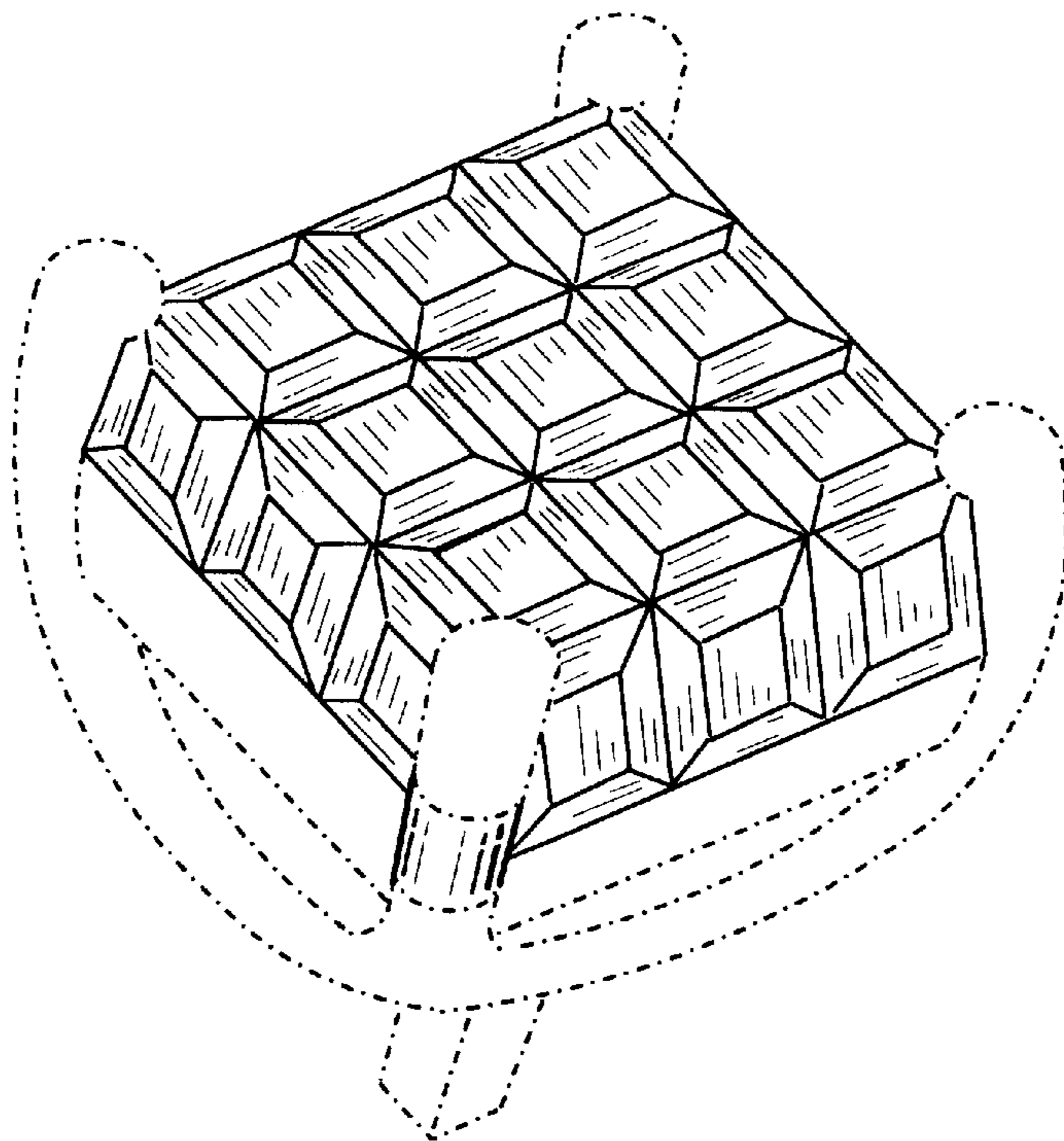

FIG. 1

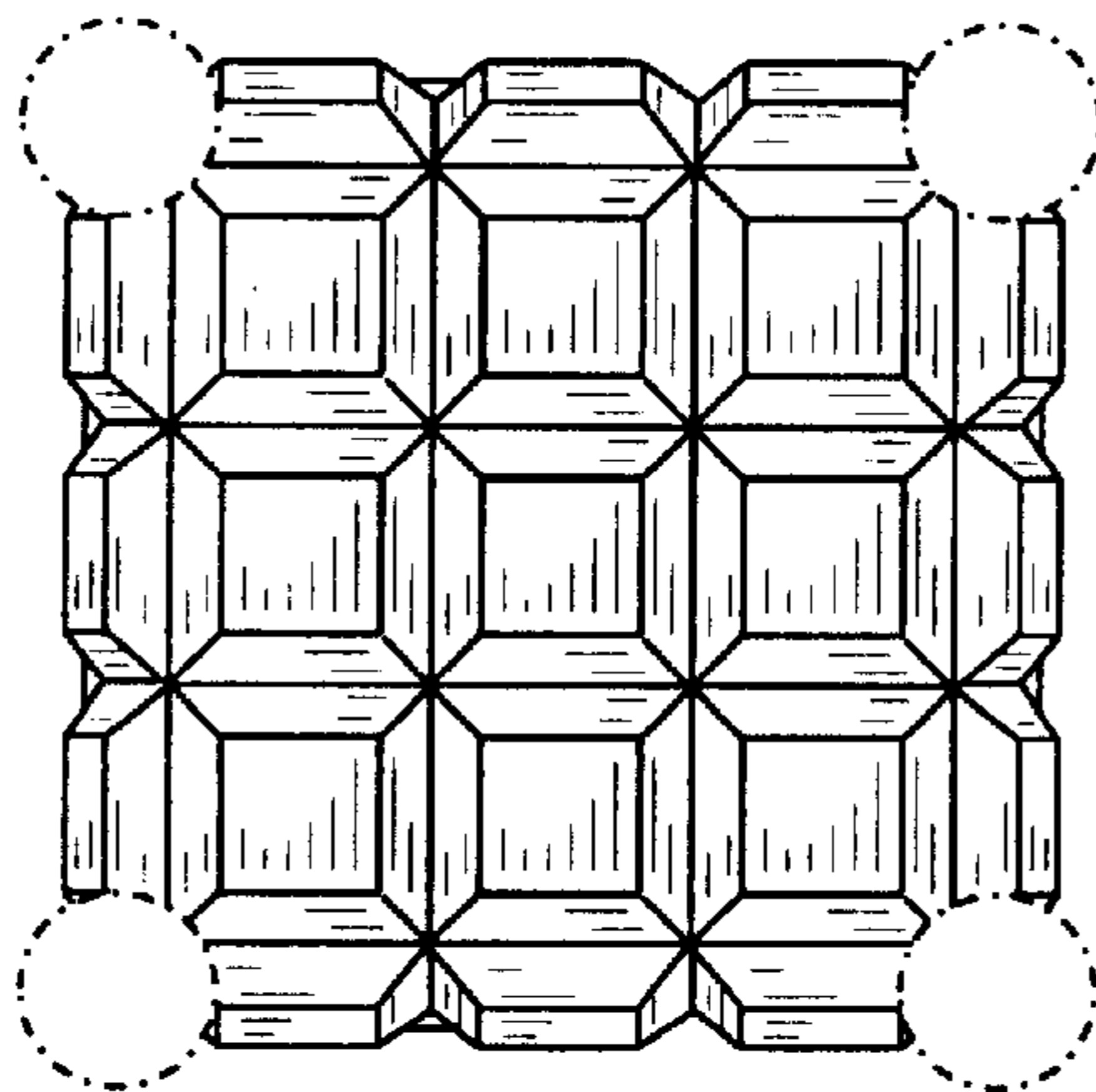

FIG. 2

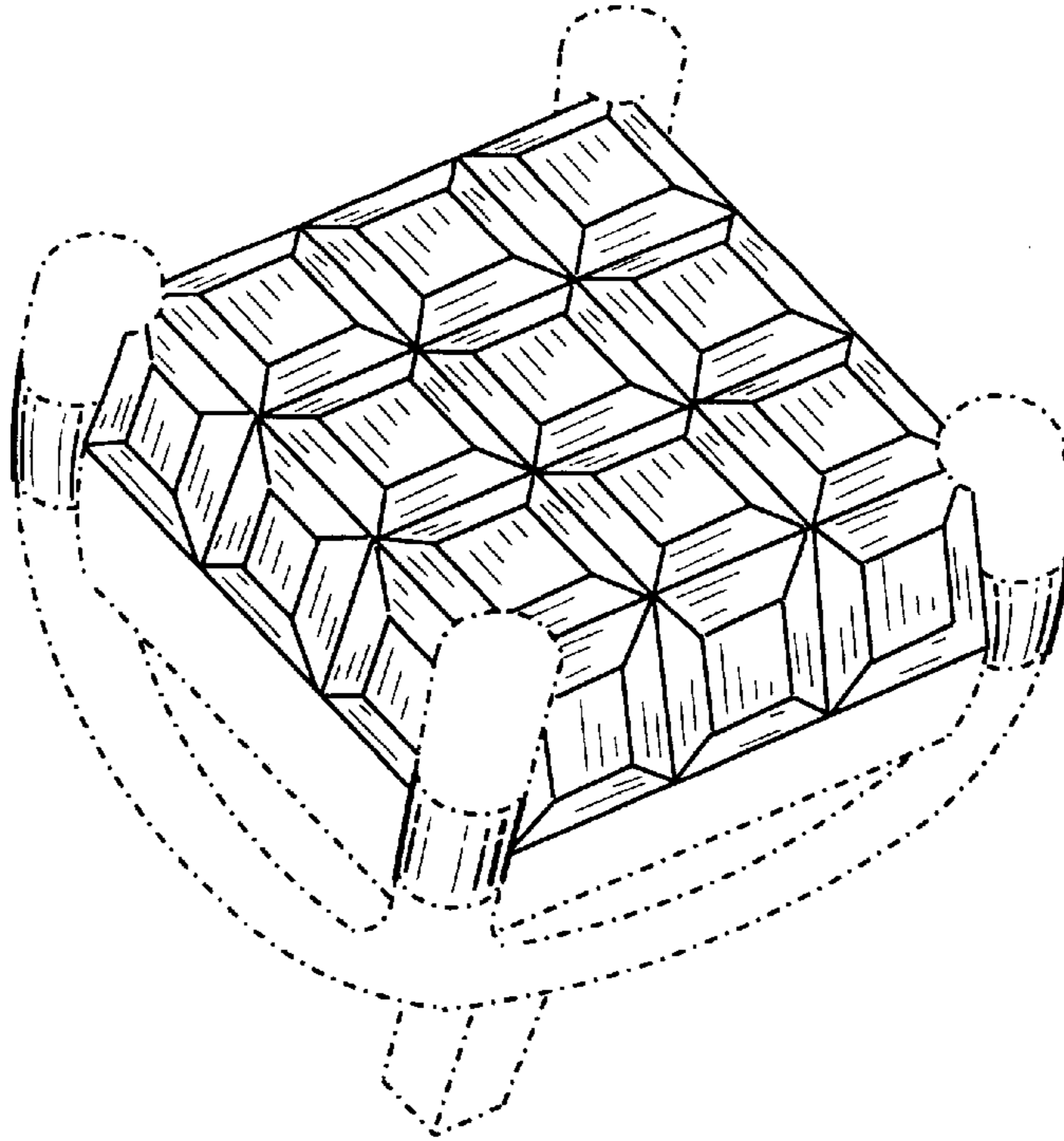

FIG. 3

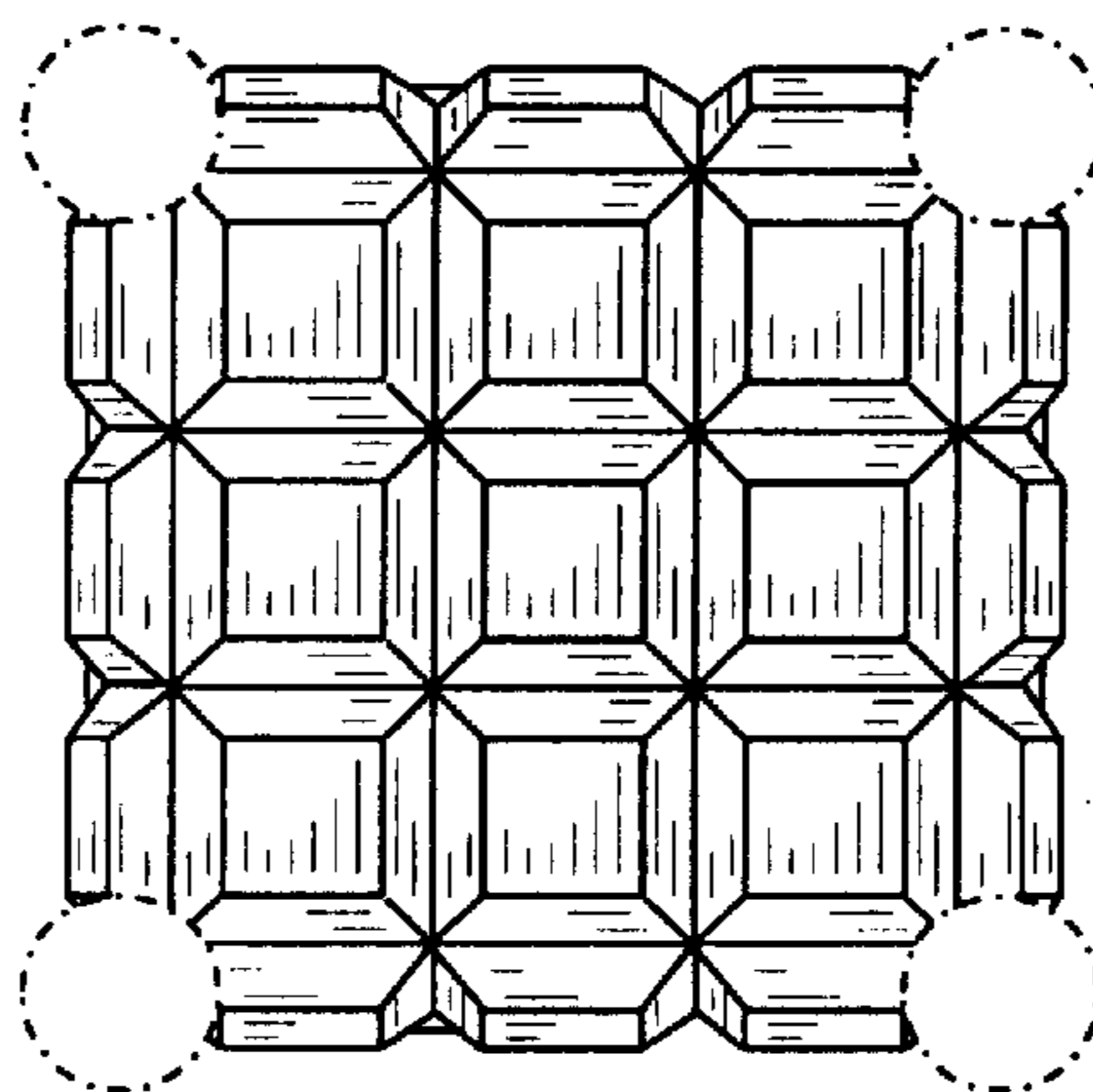

FIG. 4

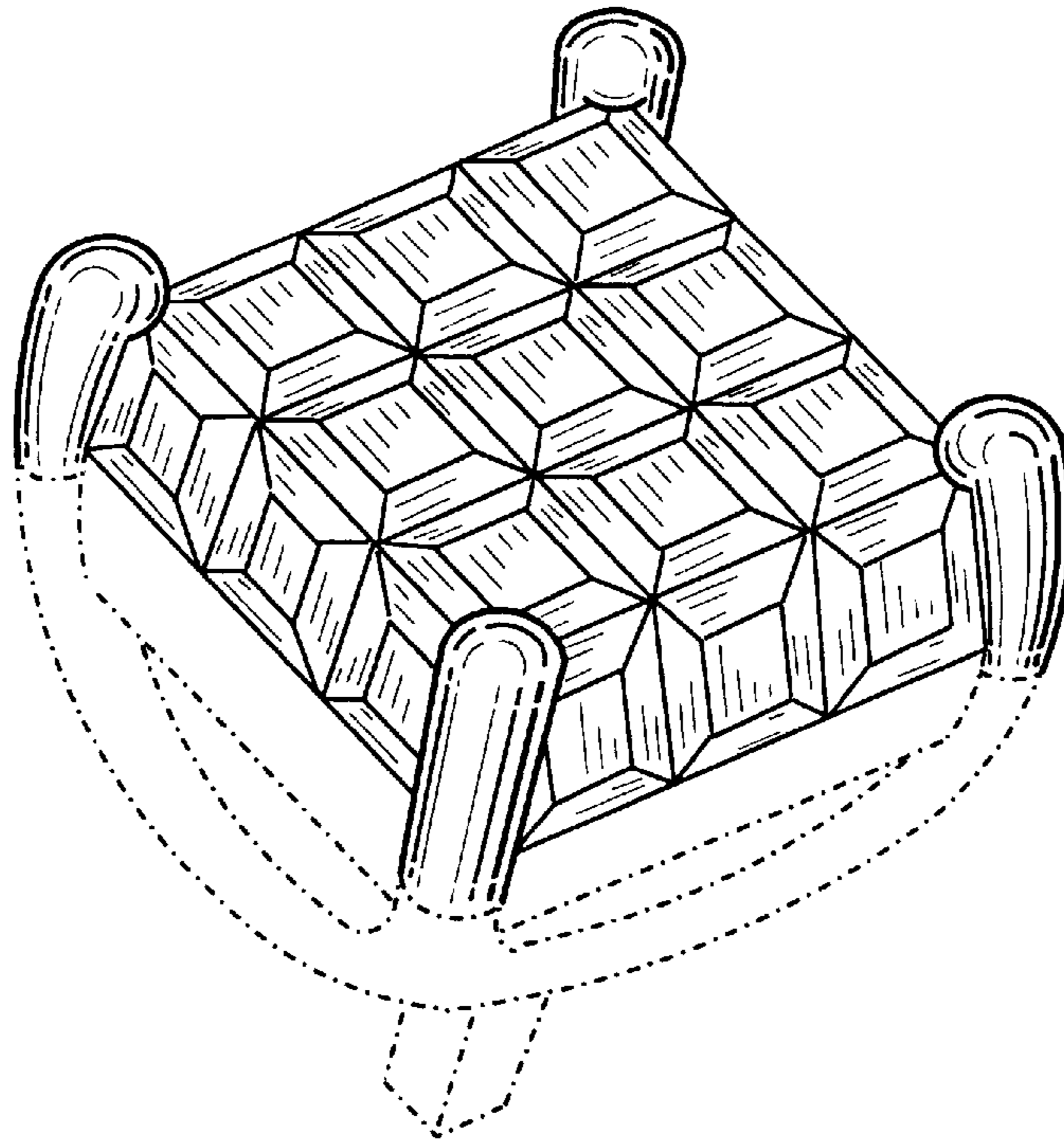

FIG. 5

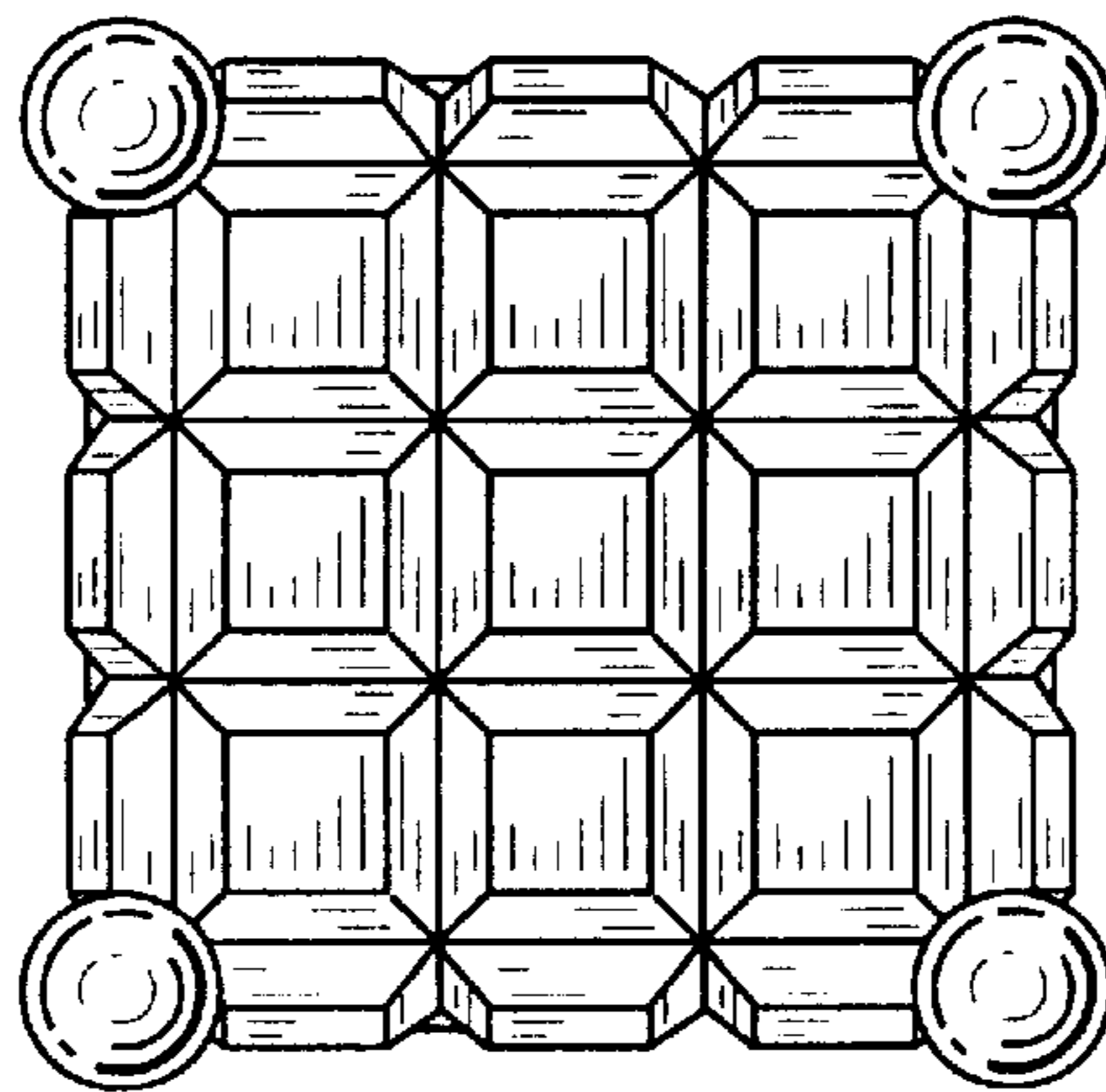

FIG. 6