



US00D456757S

(12) **United States Design Patent**
Schroeder

(10) **Patent No.:** **US D456,757 S**

(45) **Date of Patent:** **** May 7, 2002**

(54) **WHEEL**

(75) **Inventor:** **Anthony Schroeder**, Huntington Beach, CA (US)

(73) **Assignee:** **Honda Giken Kogyo Kabushiki Kaisha**, Tokyo (JP)

(**) **Term:** **14 Years**

(21) **Appl. No.:** **29/144,421**

(22) **Filed:** **Jul. 3, 2001**

(51) **LOC (7) Cl.** **12-16**

(52) **U.S. Cl.** **D12/211**

(58) **Field of Search** D12/204-211;
301/37.1, 64.1, 65

(56) **References Cited**

U.S. PATENT DOCUMENTS

D29,542 S	*	10/1898	Corscaden	D12/211
D235,431 S	*	6/1975	Scott	D12/211
D243,169 S	*	1/1977	Suzuki et al.	D12/205
D256,576 S	*	8/1980	Koch	D12/209
D282,924 S	*	3/1986	Inoue	D12/211
D361,547 S	*	8/1995	Weld	D12/211
D391,215 S	*	2/1998	Cervati	D12/209
D410,618 S	*	6/1999	Hussaini et al.	D12/211
D417,427 S	*	12/1999	Brown	D12/211
D421,417 S	*	3/2000	Weidhase	D12/209
D422,258 S	*	7/2000	Hale, Jr.	D12/211
D427,555 S	*	7/2000	Hall	D12/209

D428,379 S	*	7/2000	Donikoglu	D12/211
D430,843 S	*	9/2000	Sands	D12/211
D432,973 S	*	10/2000	Fitzgerald	D12/209
D433,659 S	*	11/2000	Frizzi	D12/211
D437,577 S	*	2/2001	Iacovelli	D12/209
D440,933 S	*	4/2001	Vian	D12/209

* cited by examiner

Primary Examiner—Stacia Cadmus

(74) *Attorney, Agent, or Firm*—Banner & Witcoff, Ltd.

(57) **CLAIM**

The ornamental design for a wheel, as shown and described.

DESCRIPTION

FIG. 1 is an elevational view of a wheel showing one embodiment of my new design;

FIG. 2 is a perspective view thereof;

FIG. 3 is a cross-sectional view taken through line 3—3 in FIG. 1.

FIG. 4 is an elevational view of a portion of a wheel showing a second embodiment of my new design; and,

FIG. 5 is a perspective view of the portion of a wheel of FIG. 4.

In FIGS. 1-3, the non-illustrated opposite side of the wheel forms no part of the claimed design. In FIGS. 4-5, any remaining portion of the wheel not illustrated forms no part of the claimed design. Additionally, the broken line showing of the central hub element in FIGS. 1-5 is for illustrative purposes only and also forms no part of the claimed design.

1 Claim, 3 Drawing Sheets

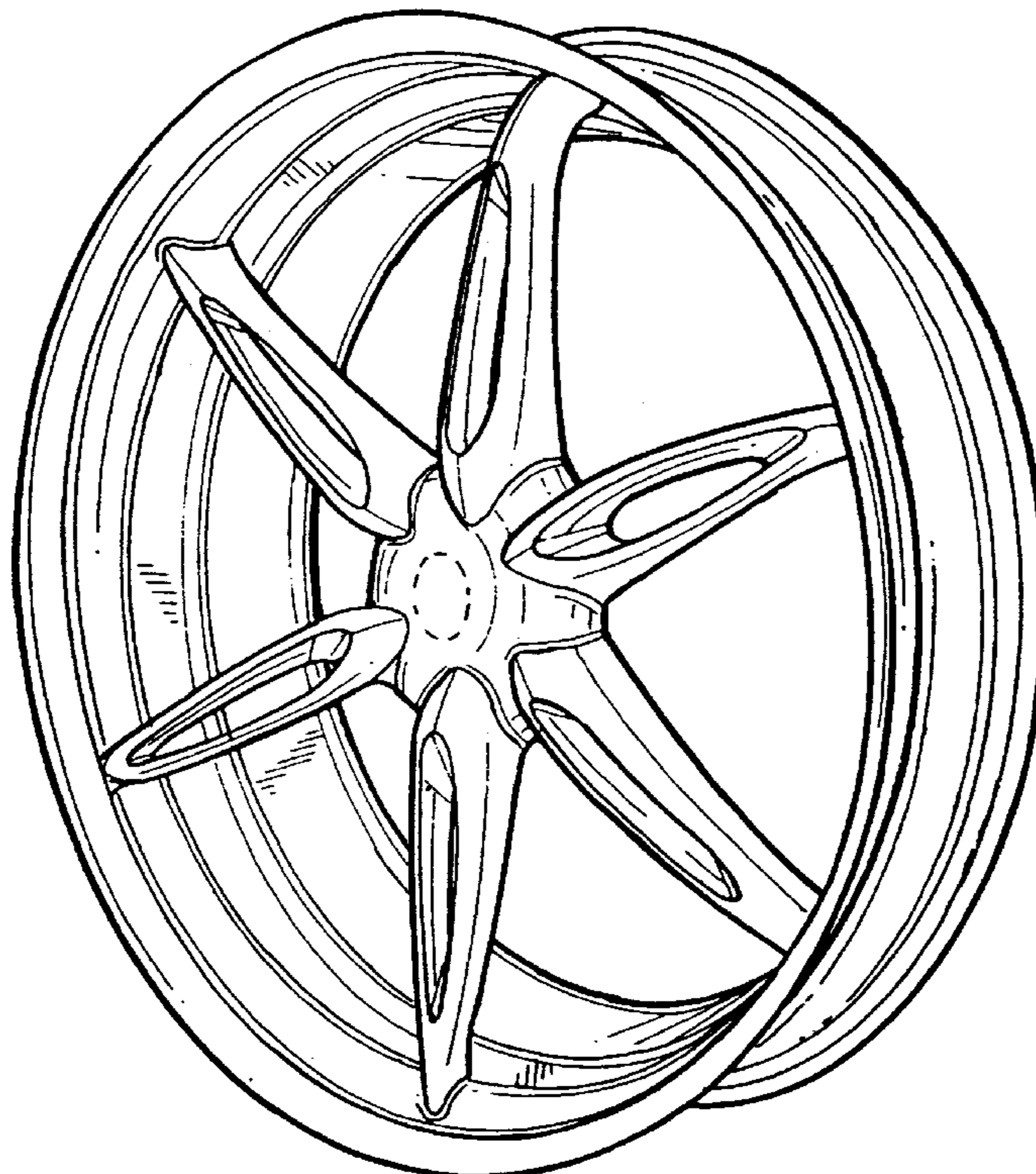

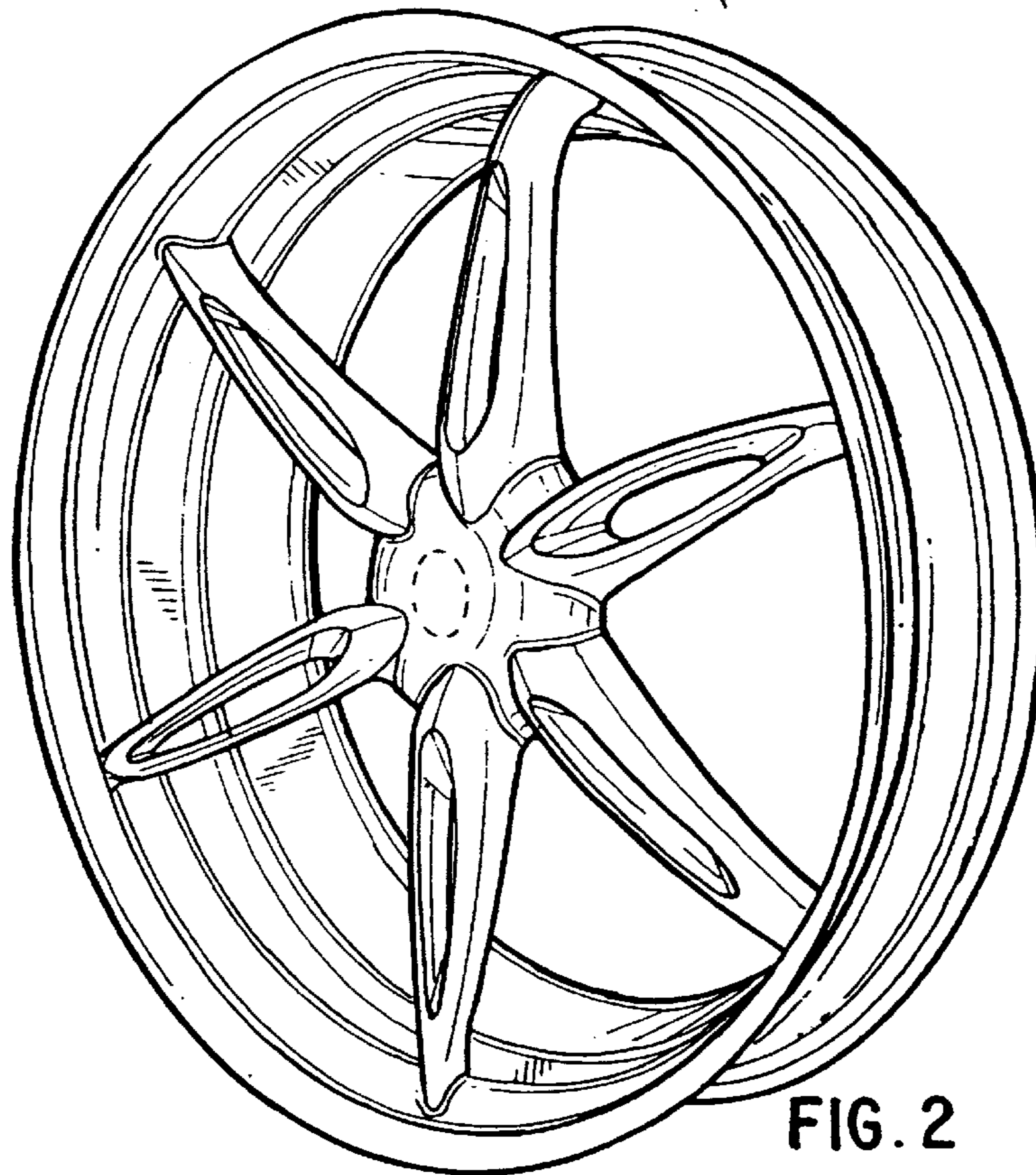
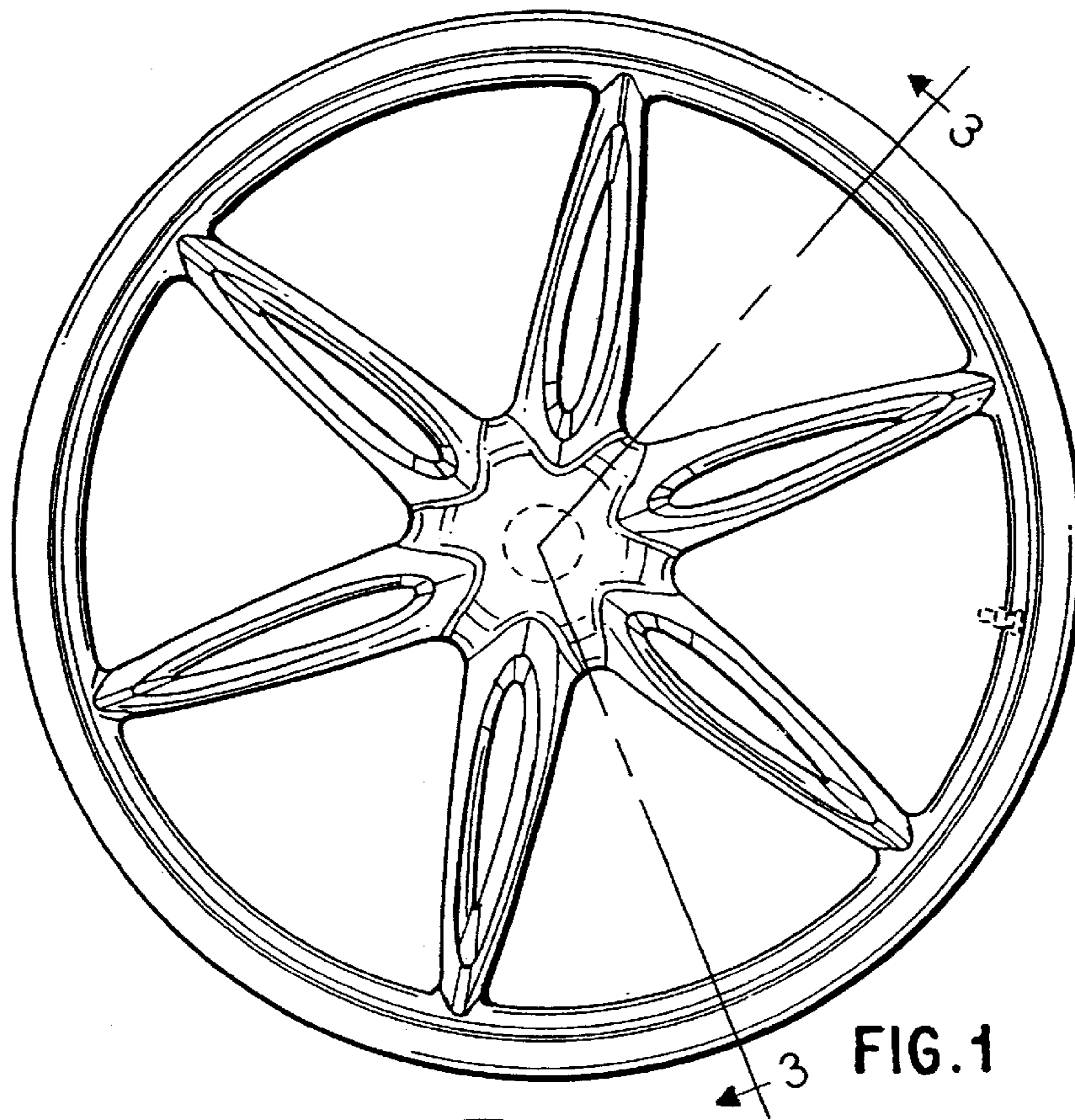

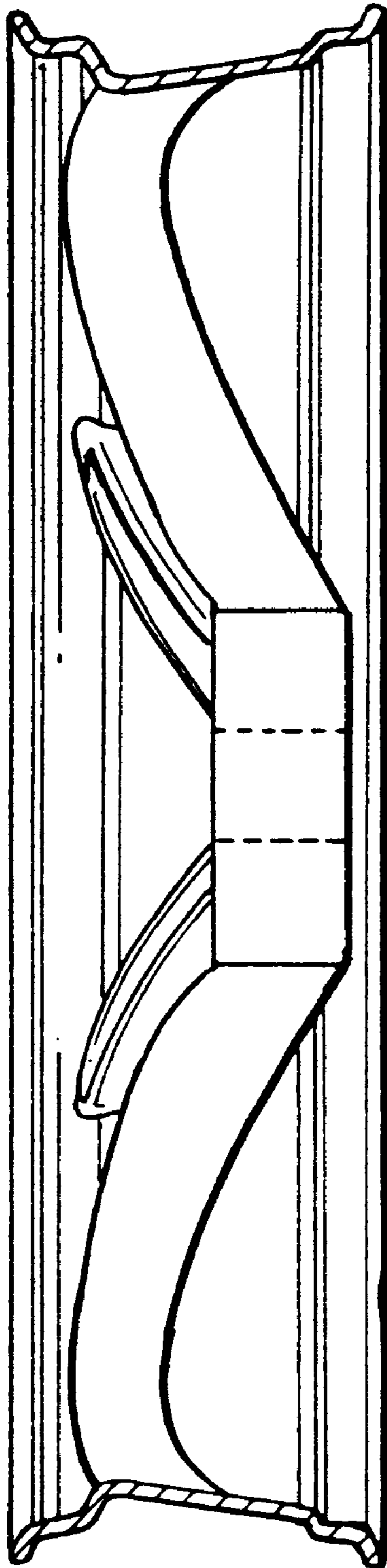

FIG. 3

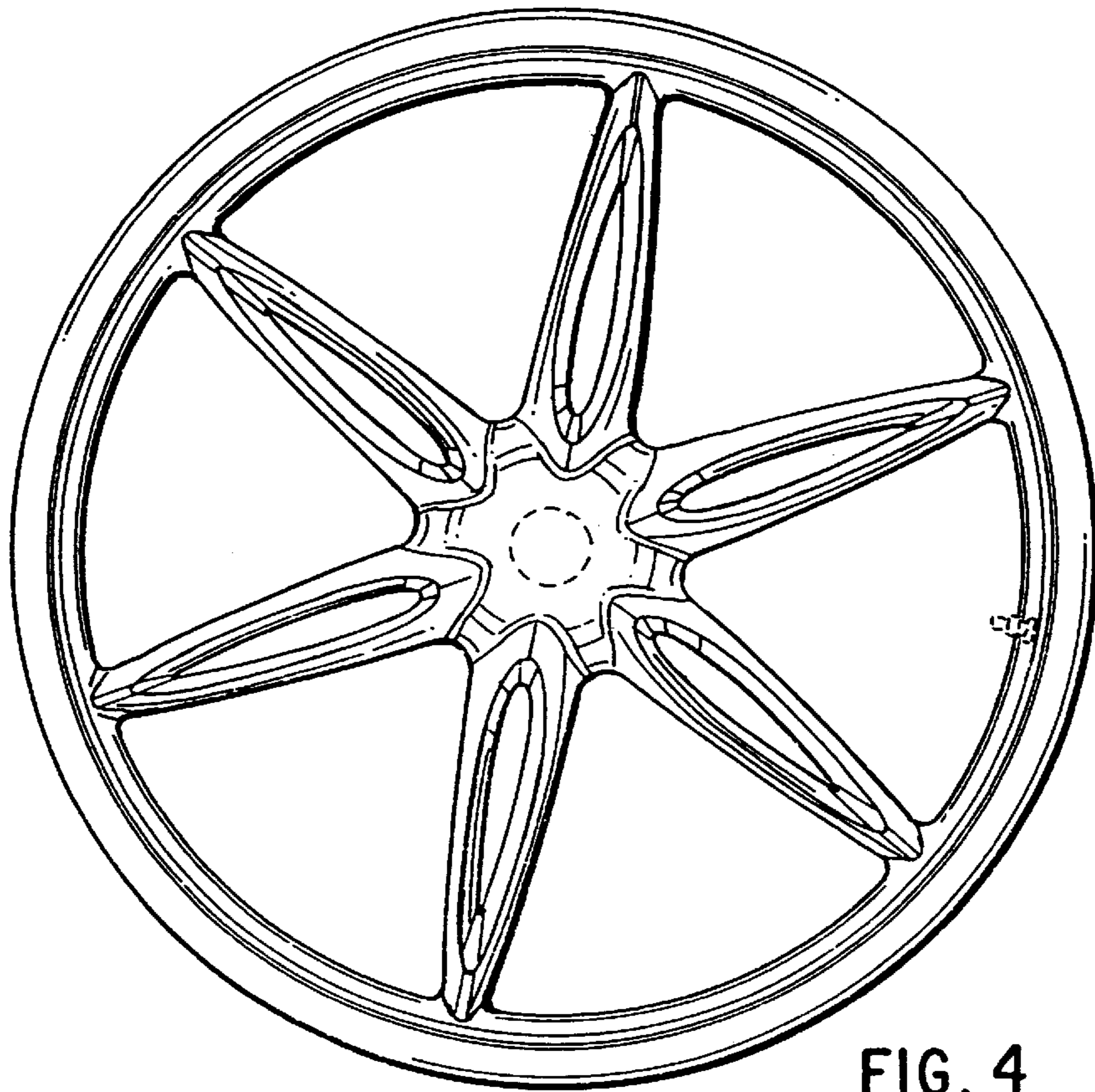

FIG. 4

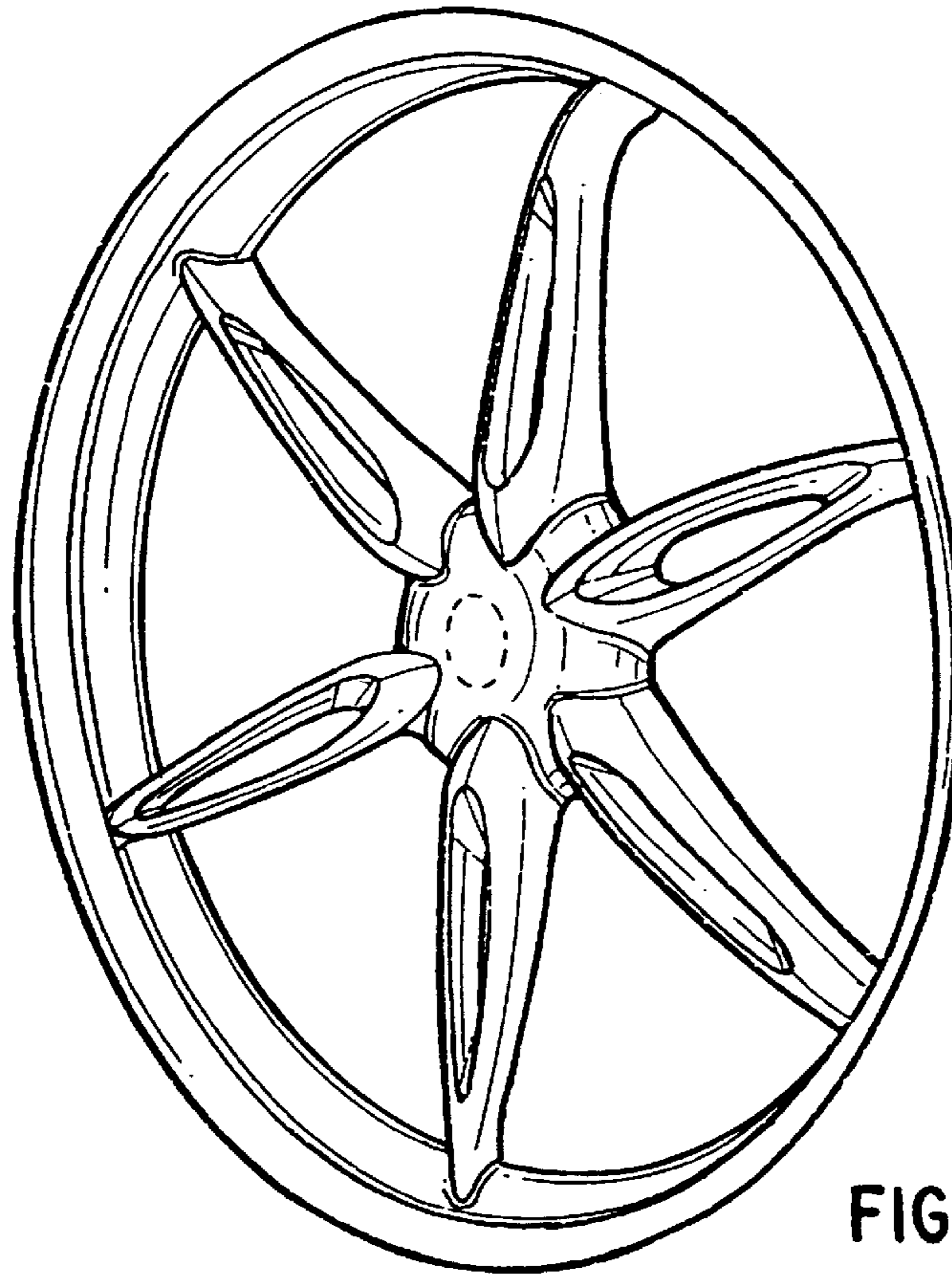

FIG. 5