



US00D456748S

(12) **United States Design Patent**
Keating et al.

(10) **Patent No.:** **US D456,748 S**

(45) **Date of Patent:** **** May 7, 2002**

(54) **MOTORCYCLE**

(75) Inventors: **Michael Keating**, Redondo Beach;
Yasuhisa Ishikawa, West Covina, both
of CA (US)

(73) Assignee: **Honda Giken Kogyo Kabushiki**
Kaisha, Tokyo (JP)

(**) Term: **14 Years**

(21) Appl. No.: **29/138,074**

(22) Filed: **Mar. 7, 2001**

(51) **LOC (7) Cl.** **12-11**

(52) **U.S. Cl.** **D12/110**

(58) **Field of Search** D12/110; 180/219

(56) **References Cited**

U.S. PATENT DOCUMENTS

D339,089 S * 9/1993 Gibbons et al. D12/110
D417,173 S * 11/1999 Yamaguchi et al. D12/110

OTHER PUBLICATIONS

Cycle World, Oct. 1997, custom motorcycle by Mike Mal-
donado, pp. 56-59.*

* cited by examiner

Primary Examiner—Alan P. Douglas

Assistant Examiner—Linda Brooks

(74) *Attorney, Agent, or Firm*—Banner & Witcoff, Ltd.

(57) **CLAIM**

The ornamental design for a motorcycle, as shown and
described.

DESCRIPTION

FIG. 1 is a frontal perspective view of a motorcycle showing
our new design;

FIG. 2 is a rear perspective view thereof;

FIG. 3 is a side elevational view of one side thereof;

FIG. 4 is a side elevational view of the other side thereof;

FIG. 5 is a front elevational view thereof;

FIG. 6 is a rear elevational view thereof; and,

FIG. 7 is a top plan view thereof.

The broken line showing of the wheels, tires and brake
rotors is for illustrative purposes only and forms no part of
the claimed design. The unillustrated bottom view forms no
part of the claimed design.

1 Claim, 6 Drawing Sheets

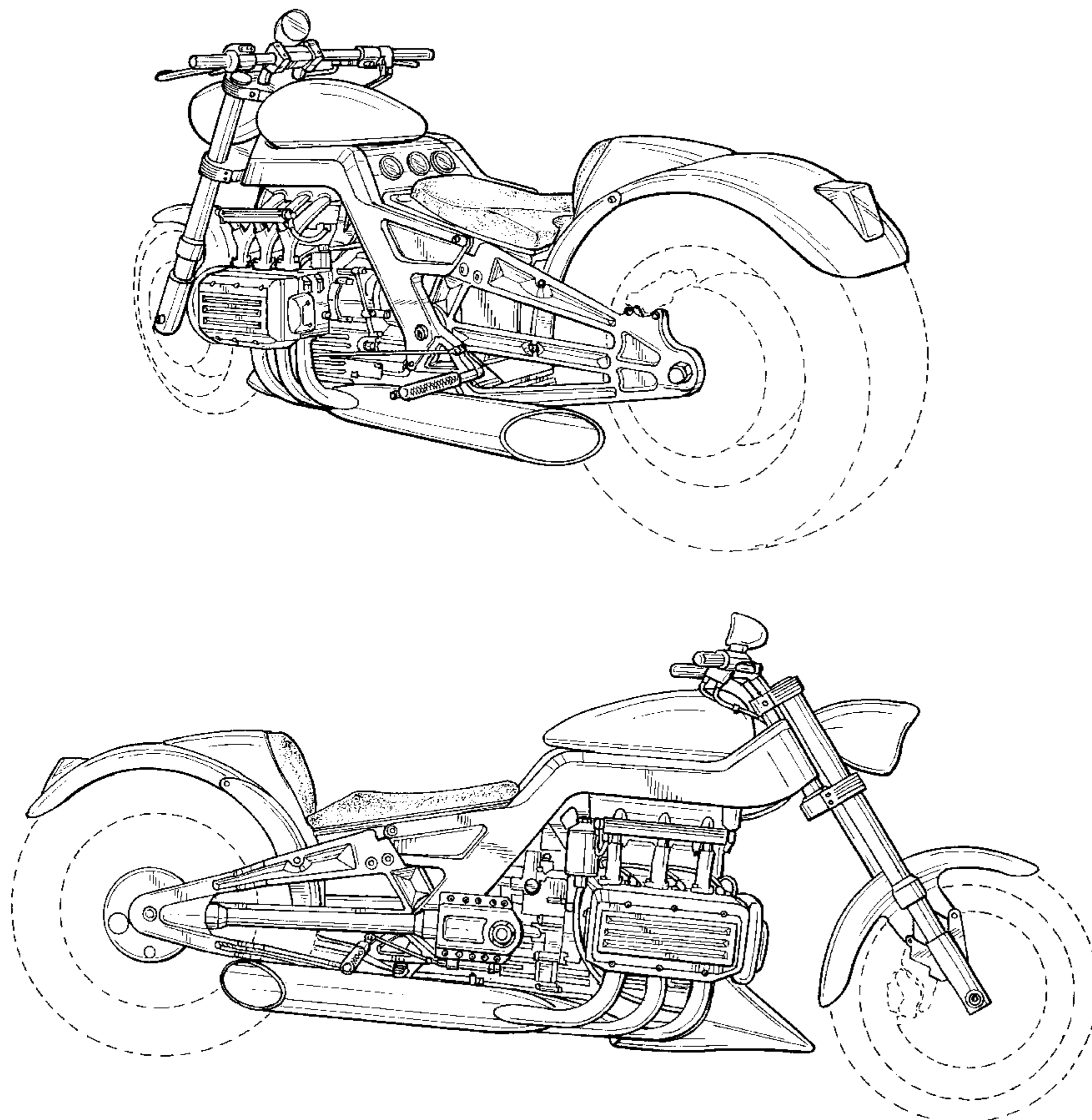

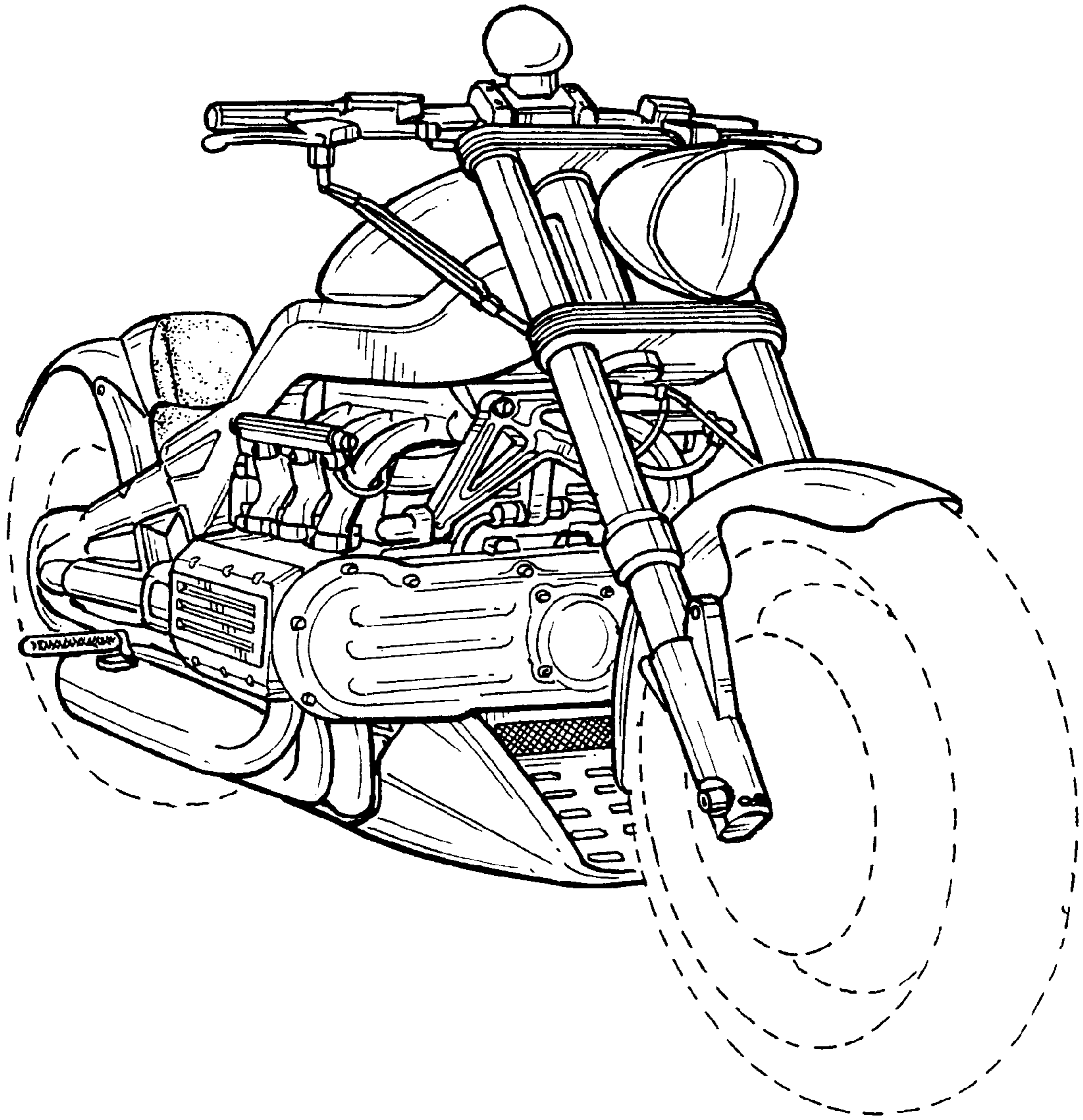

FIG. 1

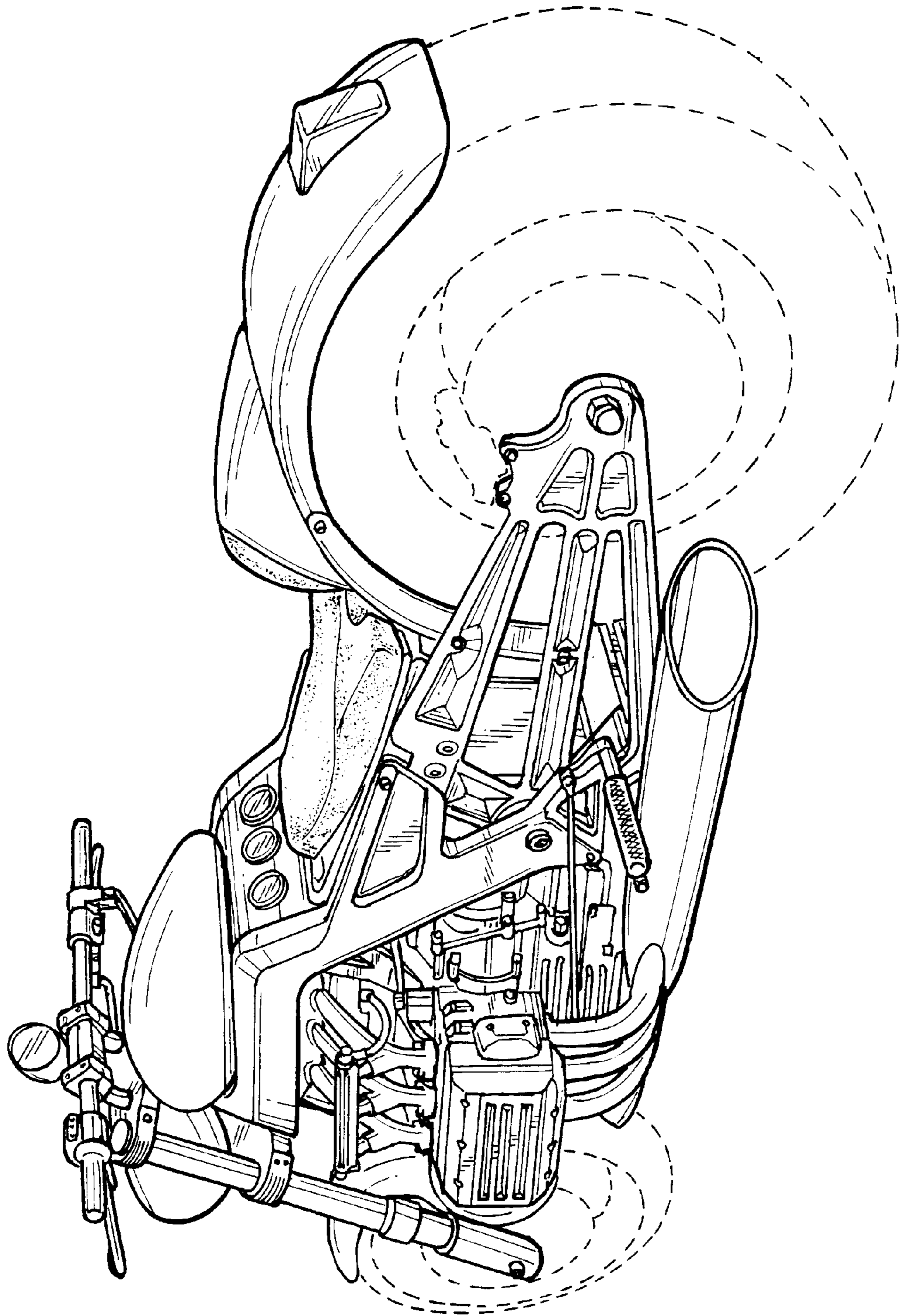

FIG. 2

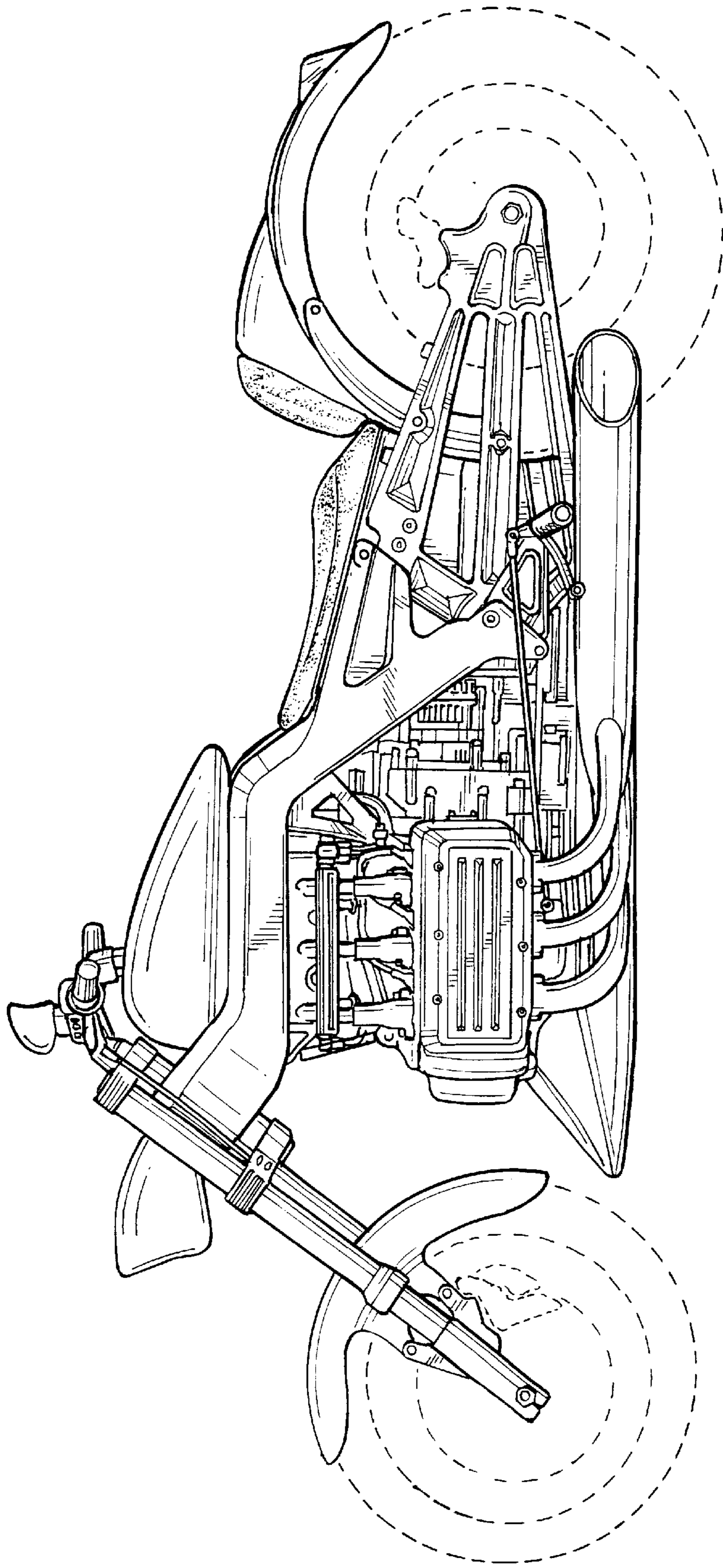

FIG. 3

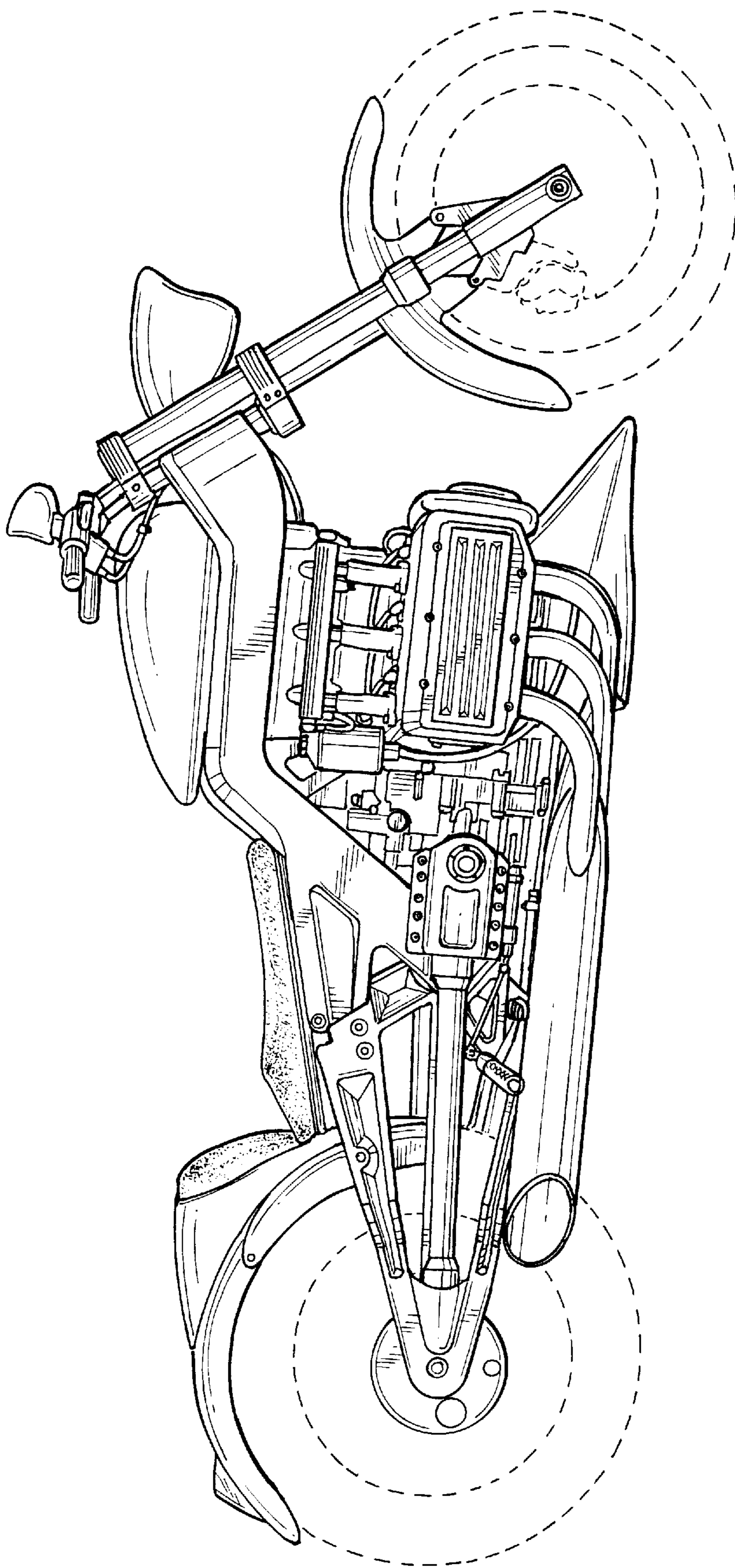

FIG. 4

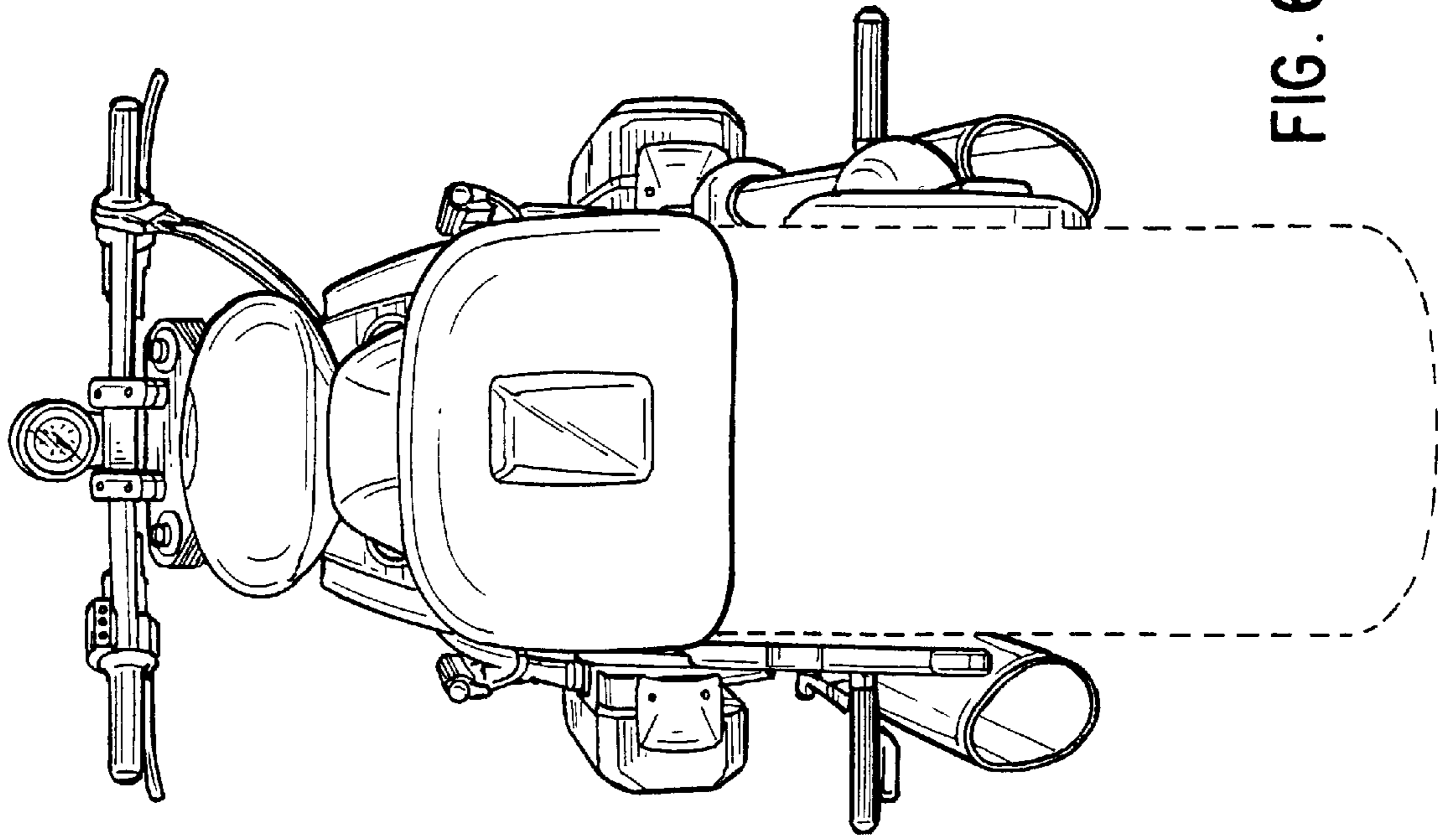

FIG. 6

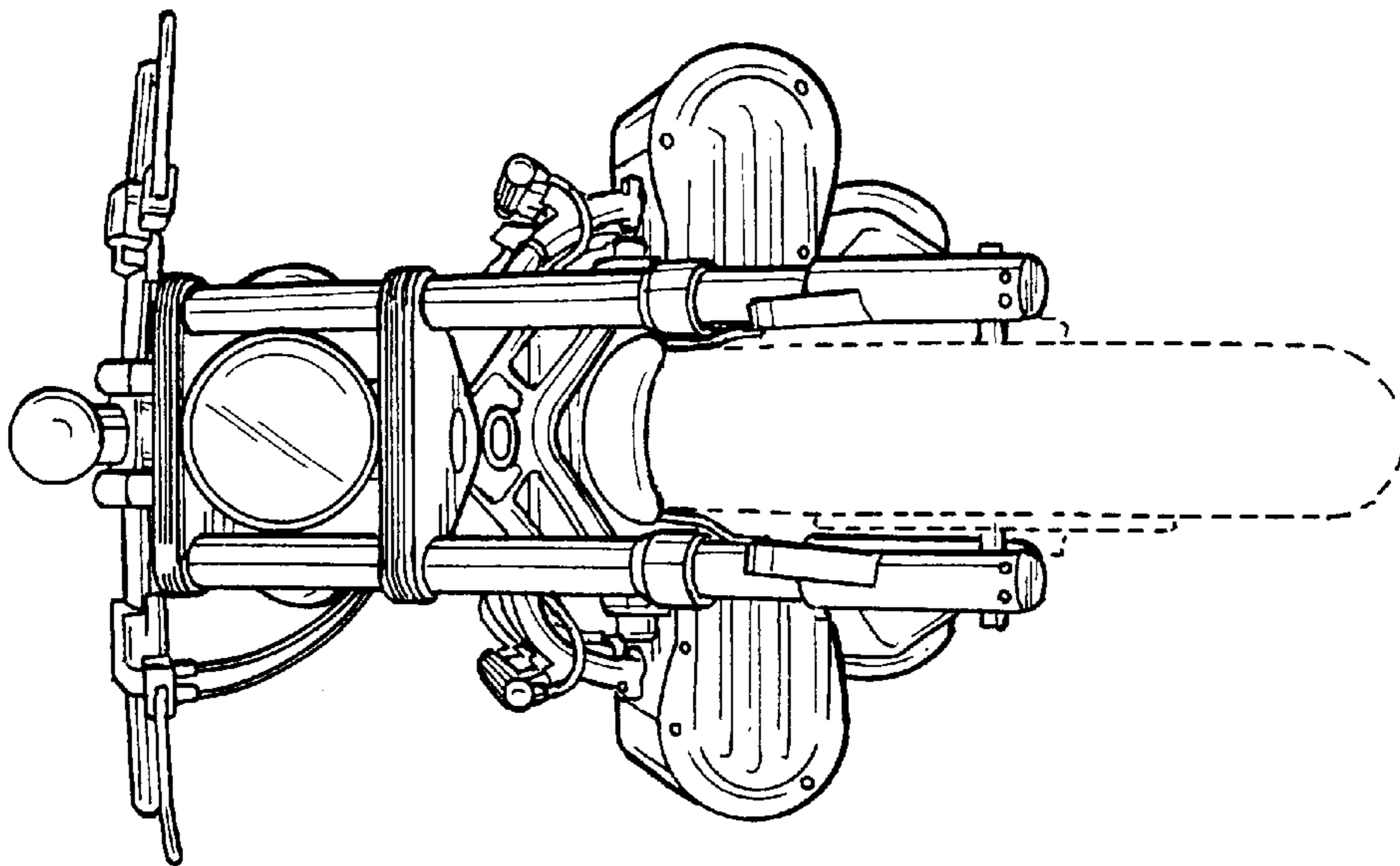

FIG. 5

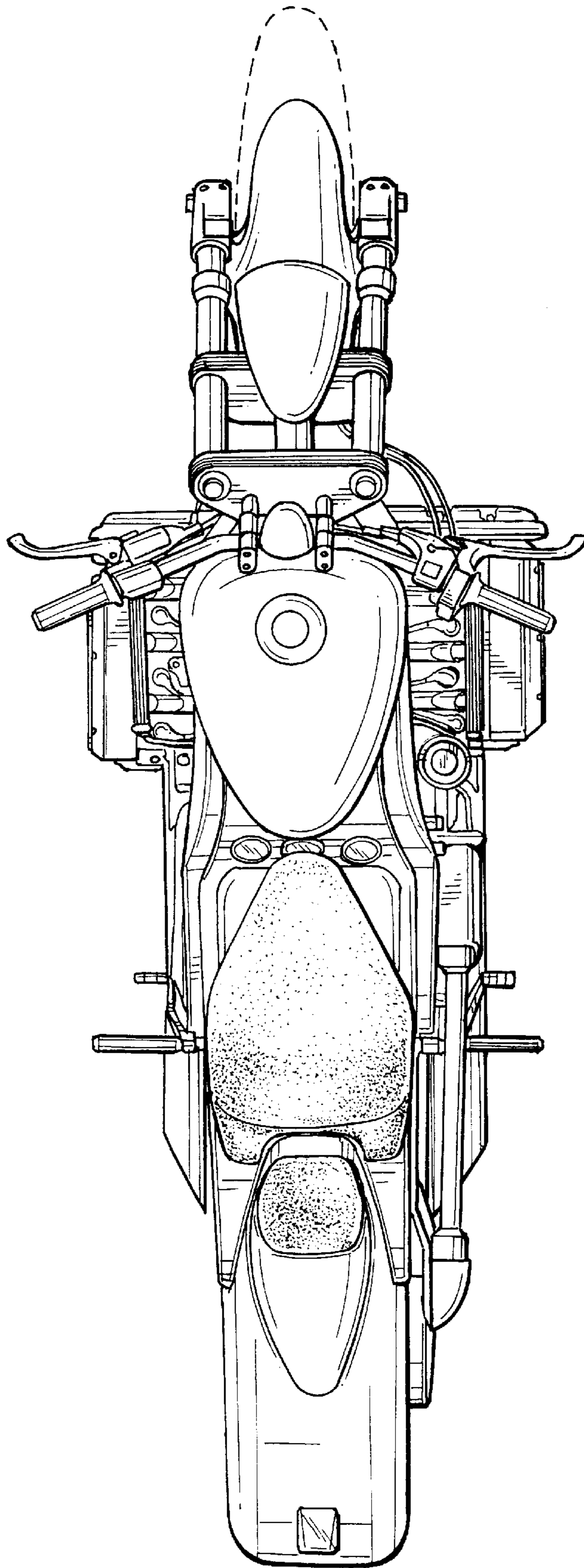

FIG. 7