



US00D456699S

(12) **United States Design Patent**  
**Nakanishi**

(10) **Patent No.:** **US D456,699 S**

(45) **Date of Patent:** **\*\* May 7, 2002**

(54) **CLIP FOR FASTENING A MOUNTING MEMBER TO AN AUTOMOBILE**

JP 596075 11/1982

\* cited by examiner

(75) Inventor: **Hideaki Nakanishi**, Toyohashi (JP)

*Primary Examiner*—Alan P. Douglas

*Assistant Examiner*—Clare E. Heflin

(73) Assignee: **Emhart LLC**, Newark, DE (US)

(74) *Attorney, Agent, or Firm*—Edward D. Murphy

(\*\*) Term: **14 Years**

(57) **CLAIM**

(21) Appl. No.: **29/141,062**

The ornamental design for a clip for fastening a mounting member to an automobile, as shown and described.

(22) Filed: **Apr. 27, 2001**

**DESCRIPTION**

(51) **LOC (7) Cl.** ..... **08-08**

(52) **U.S. Cl.** ..... **D8/382; D8/386**

(58) **Field of Search** ..... D8/382, 384–393;  
411/500, 508–511, 455, 908, 913, 923;  
24/297, 703

FIG. 1 is a perspective view of a clip of the present invention;

FIG. 2 is a front elevational view thereof, the rear elevational view being a mirror image of the front;

FIG. 3 is a right side elevational view thereof, the left side being a mirror image of the right side;

FIG. 4 is a top plan view thereof;

FIG. 5 is a bottom plan view thereof;

FIG. 6 is a sectional view taken along line 6—6 of FIG. 2;

FIG. 7 is a sectional view taken along line 7—7 of FIG. 2;

FIG. 8 is a front elevational view, similar to FIG. 2, in which the clip is shown connecting the broken line representation of a trim board to the body of an automobile; and,

FIG. 9 is a front elevational view, similar to FIG. 2, in which the clip is shown connecting the broken line representation of a trim board to another body of an automobile.

The broken line representation of the trim board and the body of an automobile in FIGS. 8 and 9 are for illustrative purposes only and form no part of the claimed design.

(56) **References Cited**

**U.S. PATENT DOCUMENTS**

3,272,059	A	*	9/1966	Lyday et al.	
3,550,217	A	*	12/1970	Collyer	
3,745,612	A	*	7/1973	Seckerson	411/509
D268,006	S	*	2/1983	Wollar	D8/393
D293,883	S	*	1/1988	Hirohata	D8/386
D297,613	S	*	9/1988	Yokoyama et al.	D8/382
D297,615	S	*	9/1988	Nakama	D8/382
4,987,656	A	*	1/1991	Sato	24/297
5,573,362	A	*	11/1996	Asami et al.	411/509
5,689,863	A	*	11/1997	Sinozaki	24/297

**FOREIGN PATENT DOCUMENTS**

JP 521547 9/1979

**1 Claim, 5 Drawing Sheets**

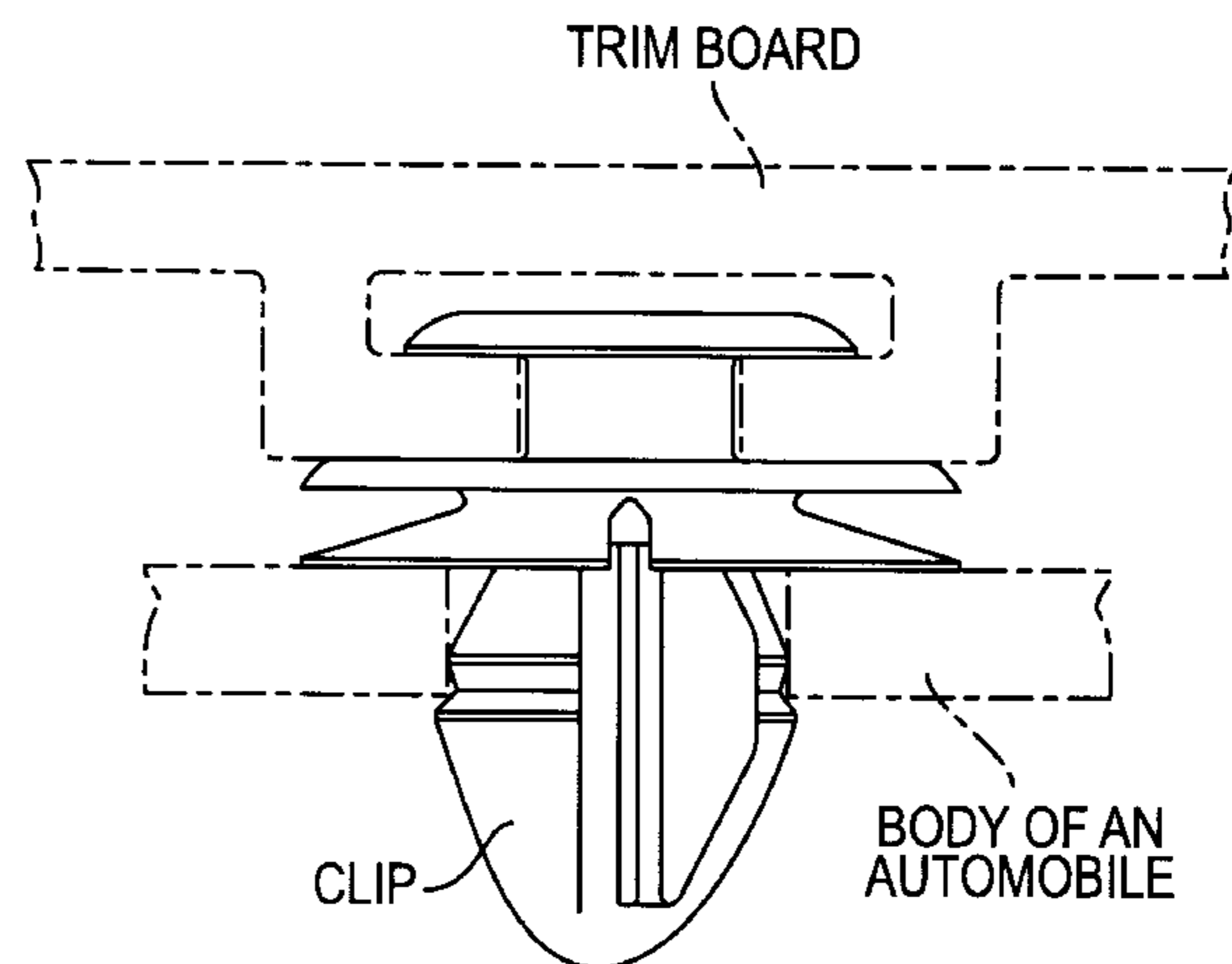
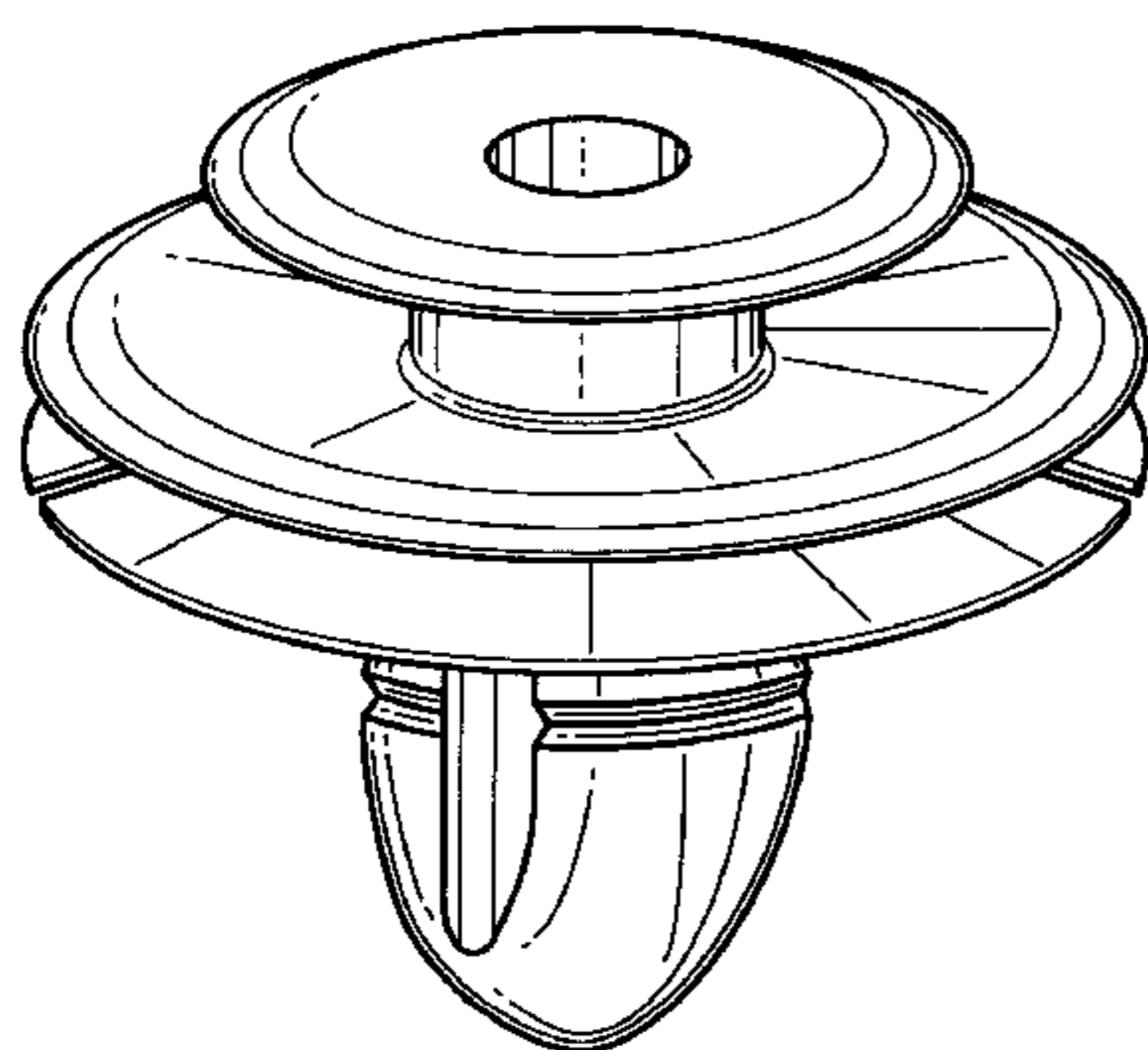

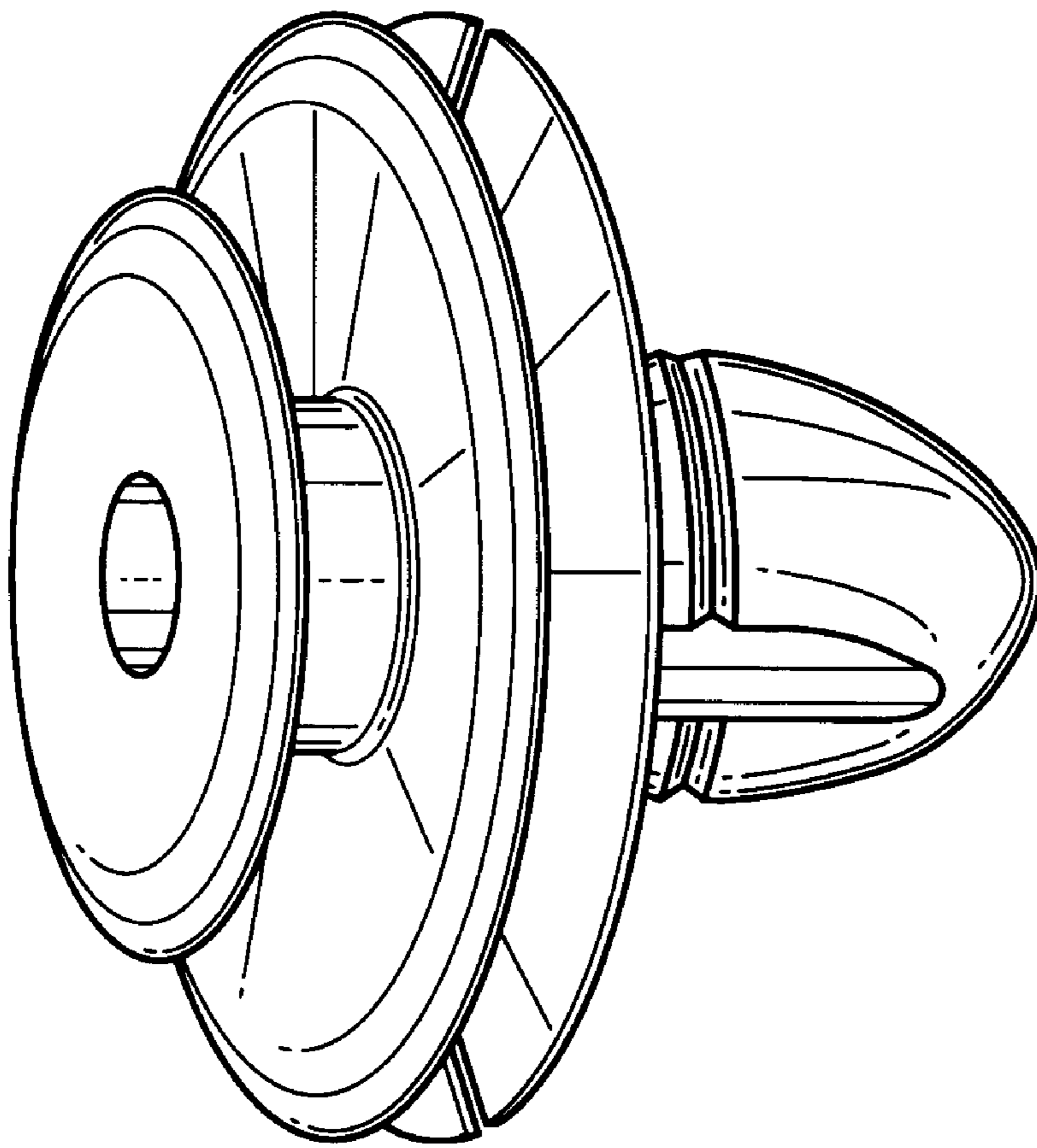

FIG. 1

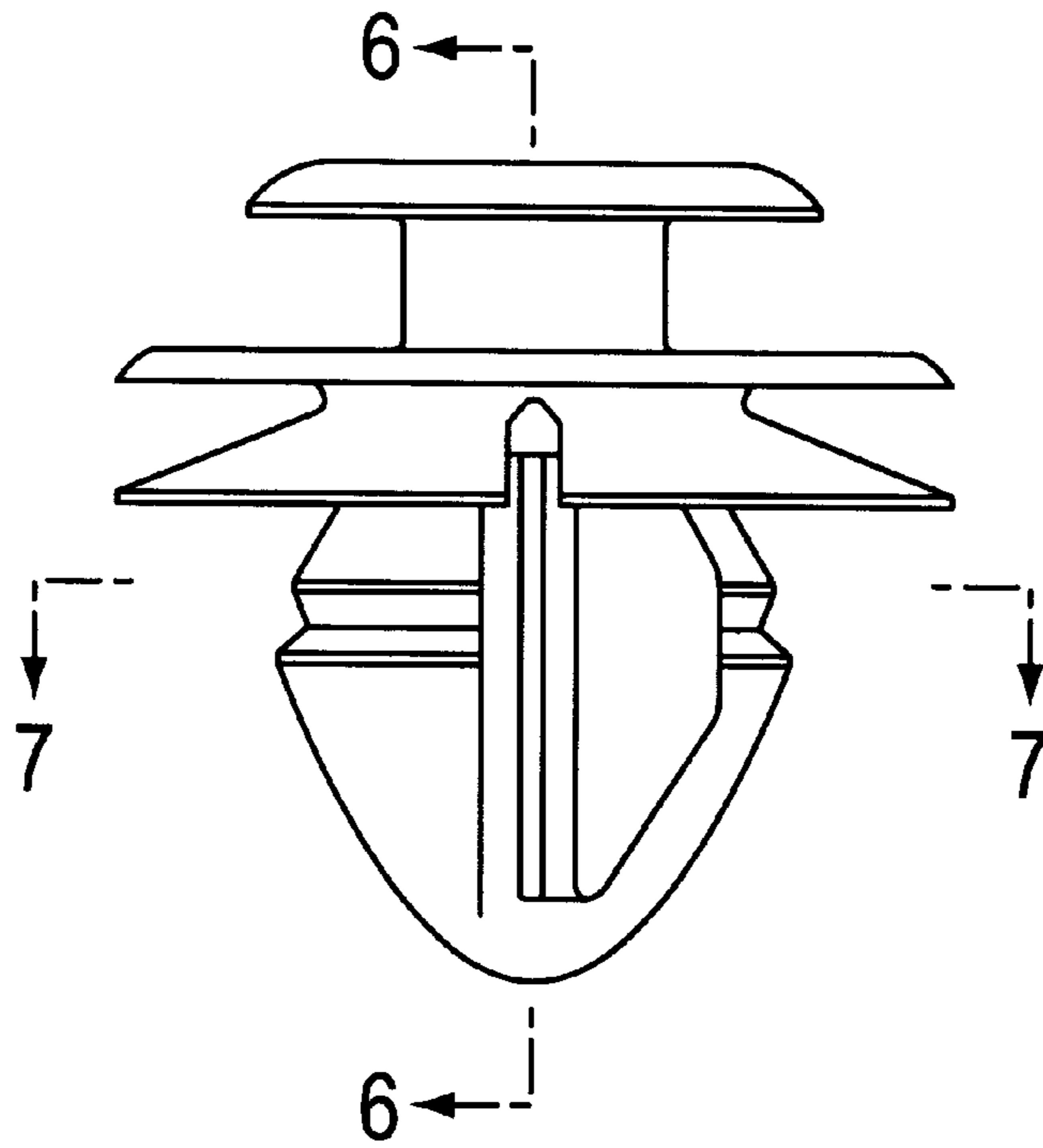

FIG. 2

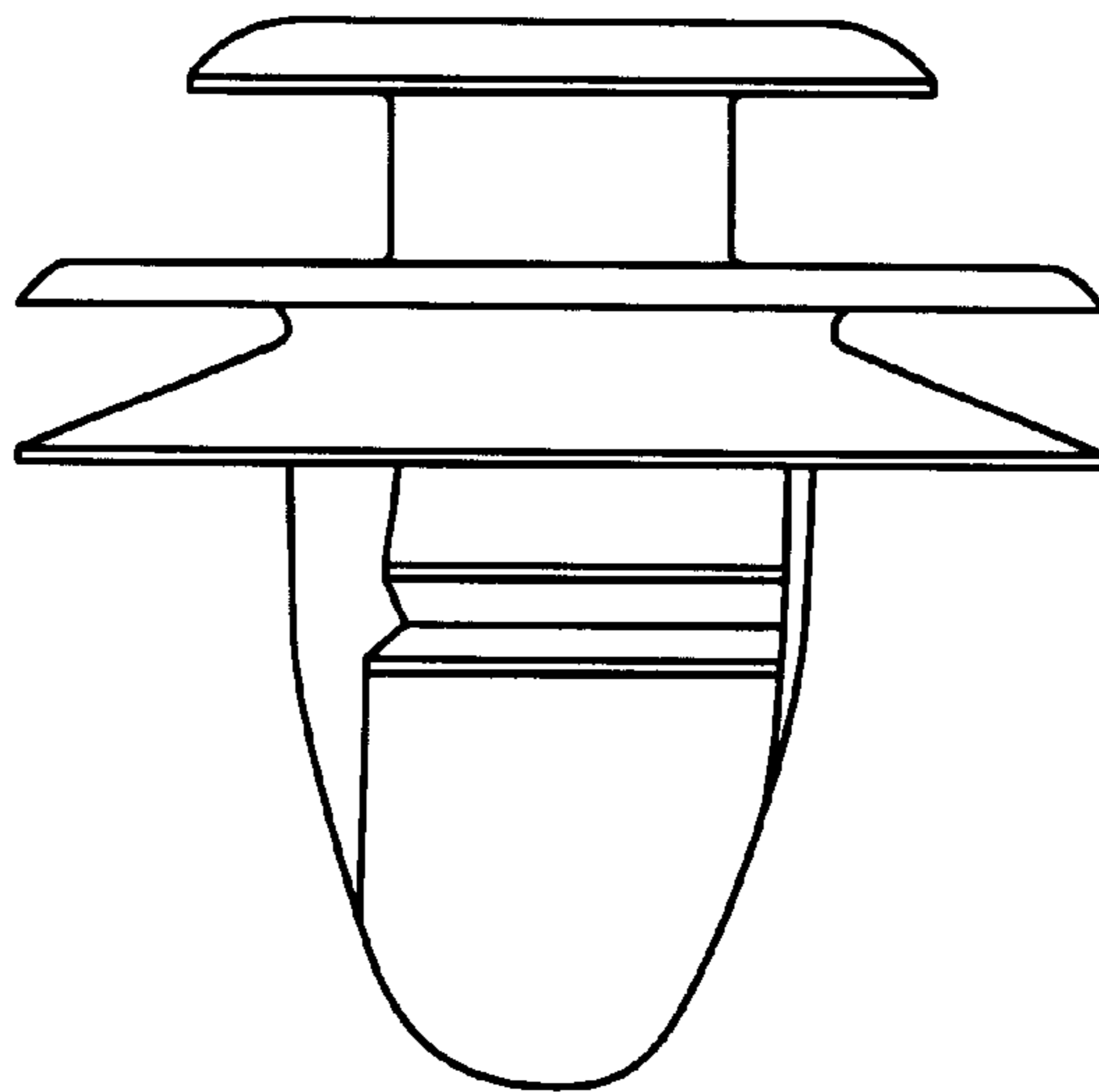

FIG. 3

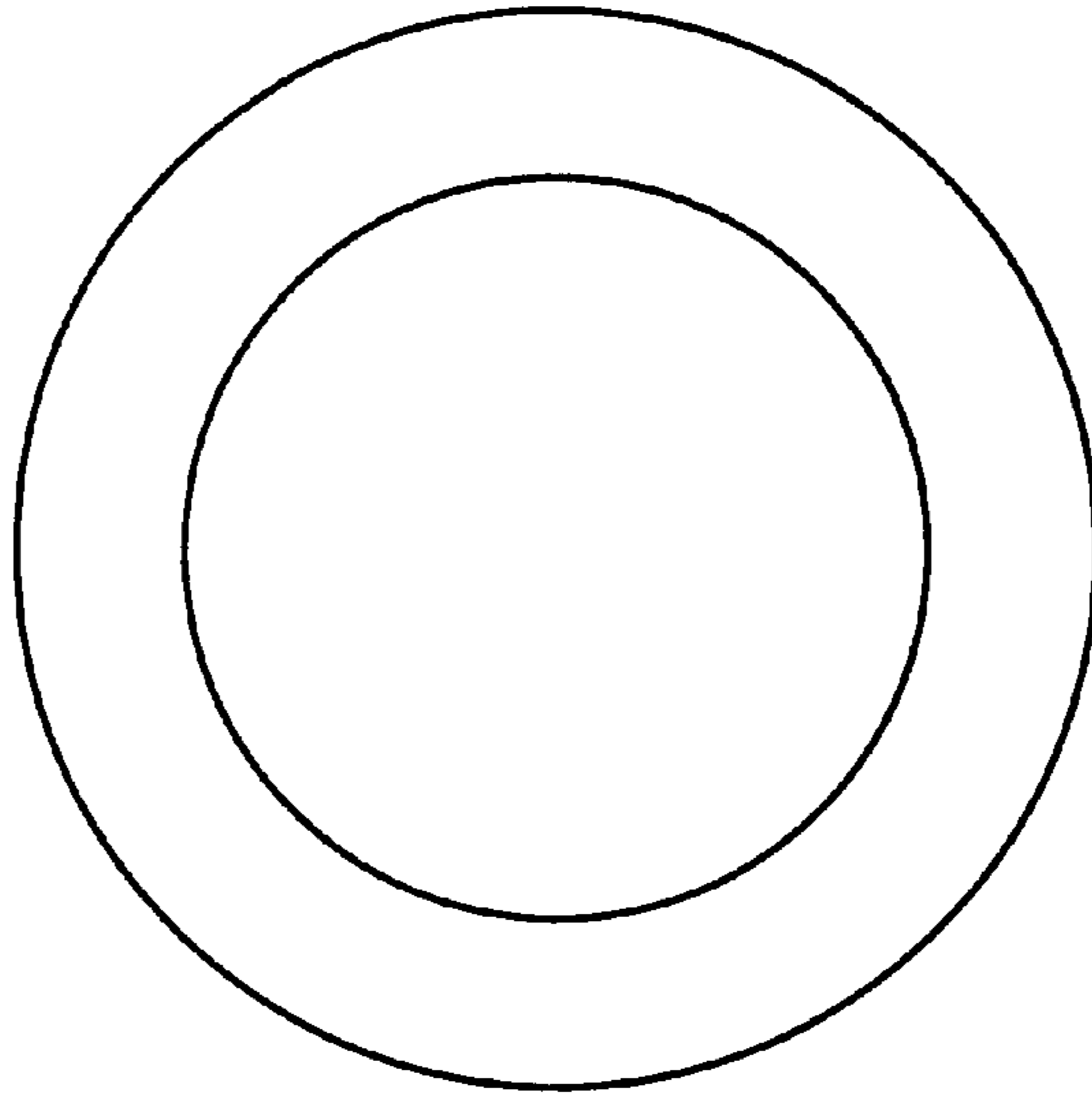

FIG. 4

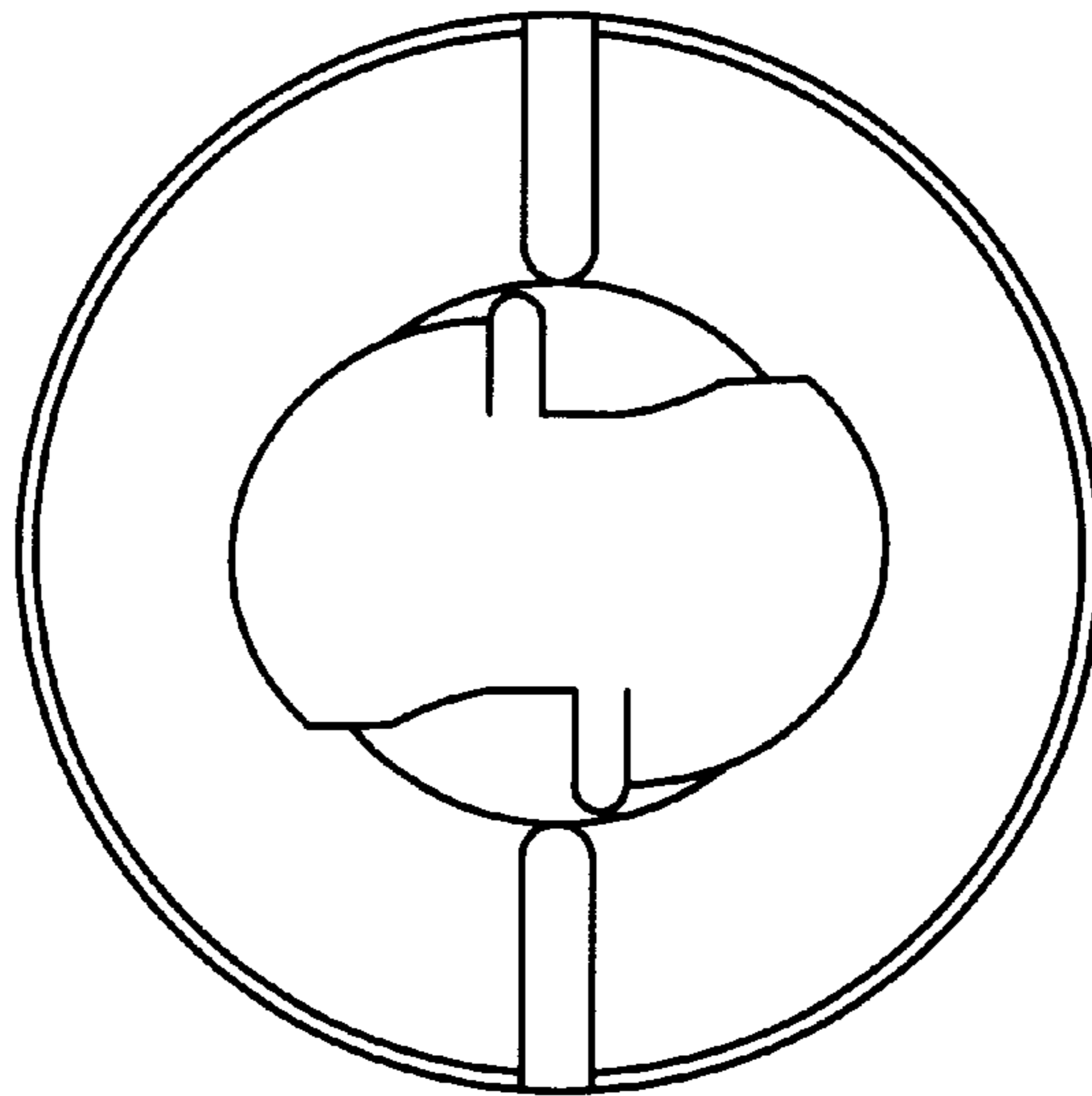

FIG. 5

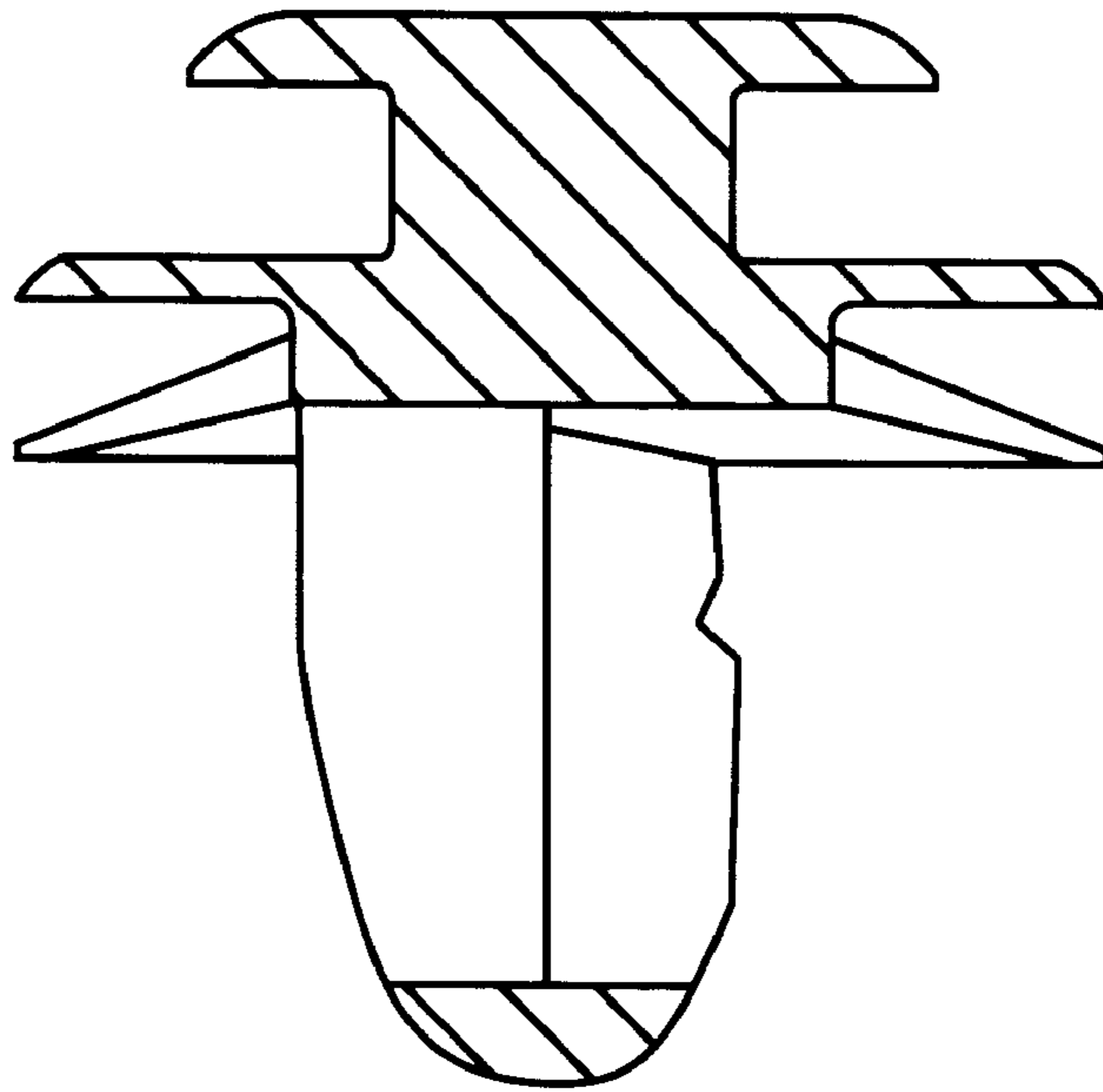

FIG. 6

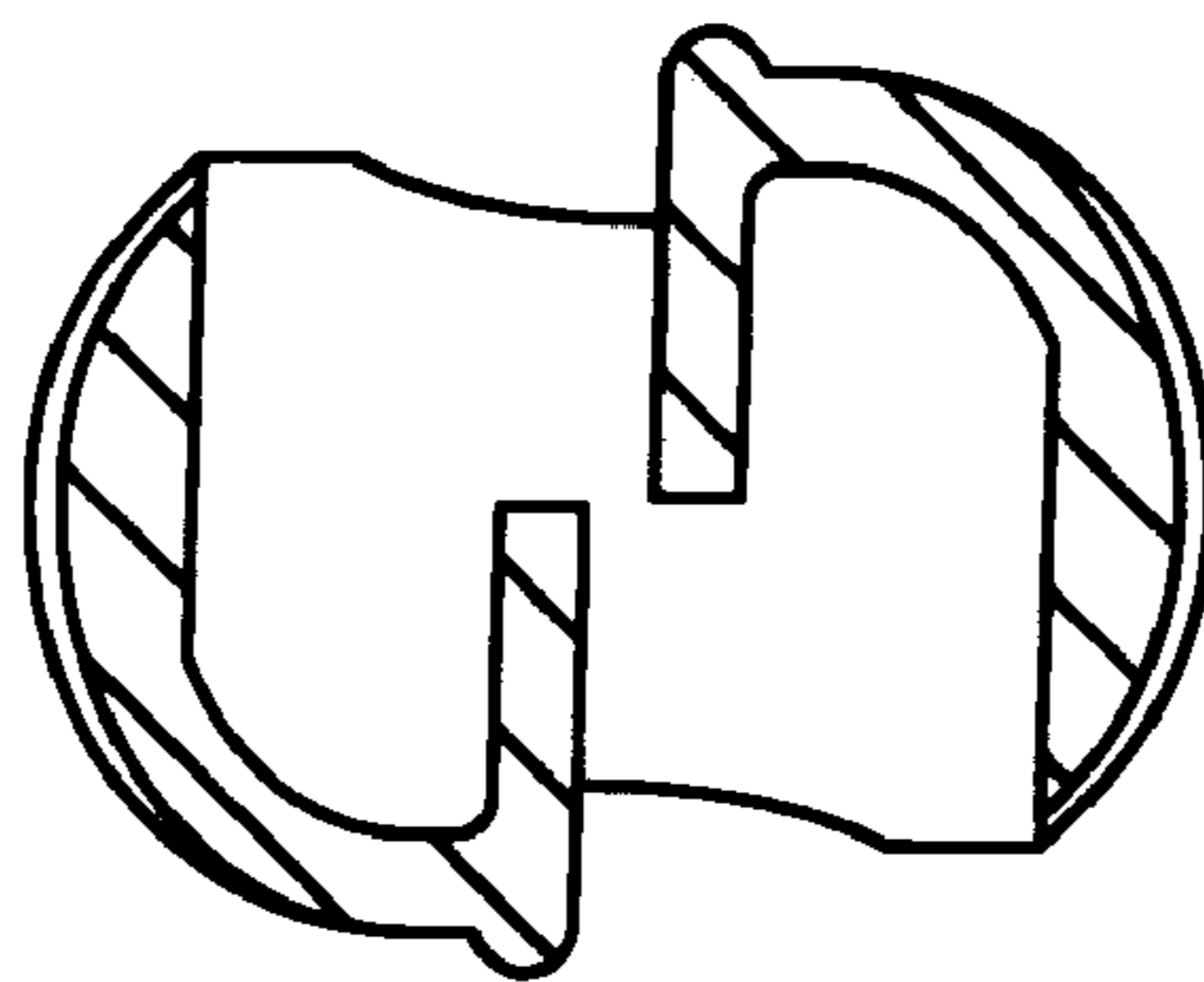

FIG. 7

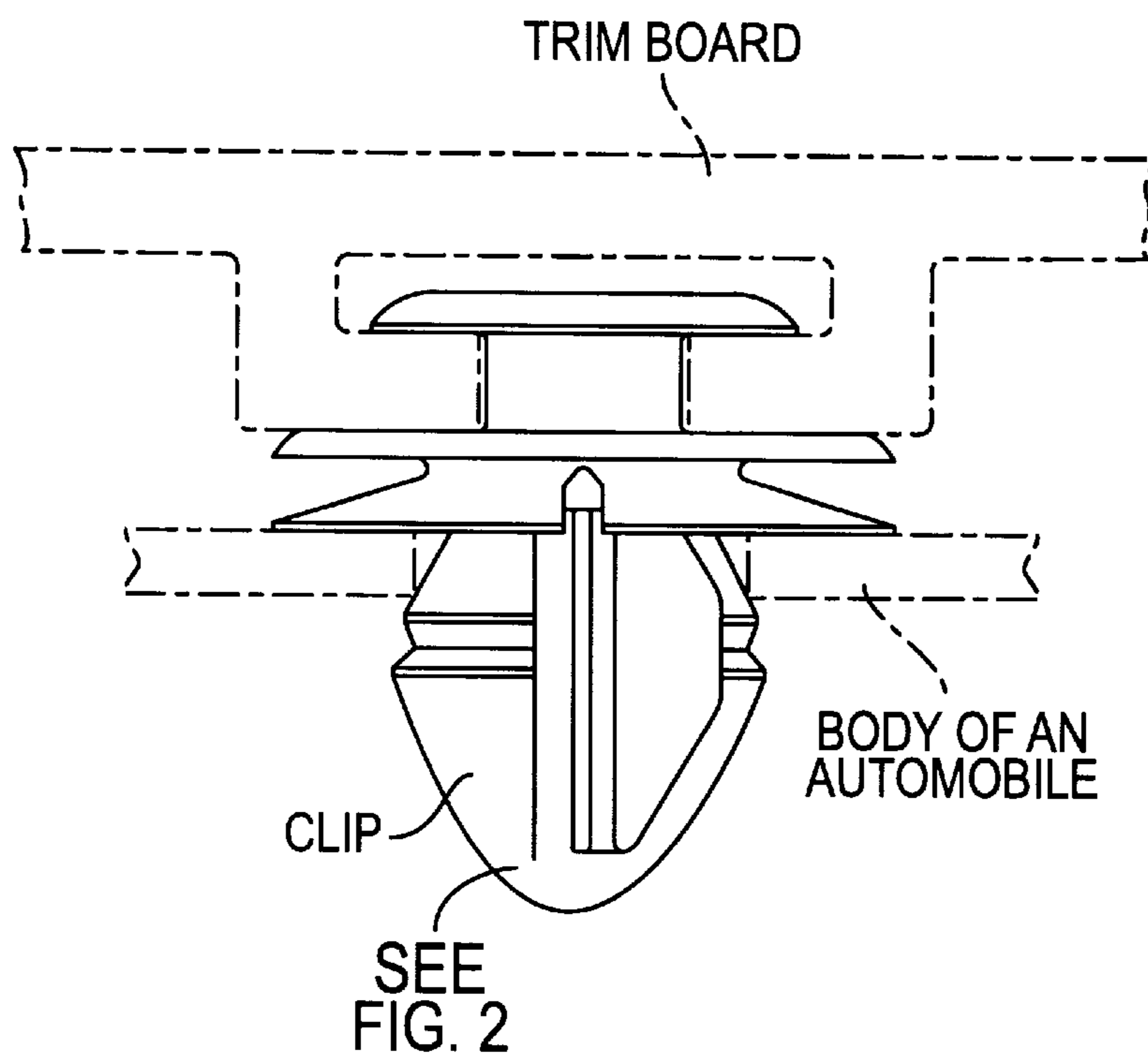

FIG. 8

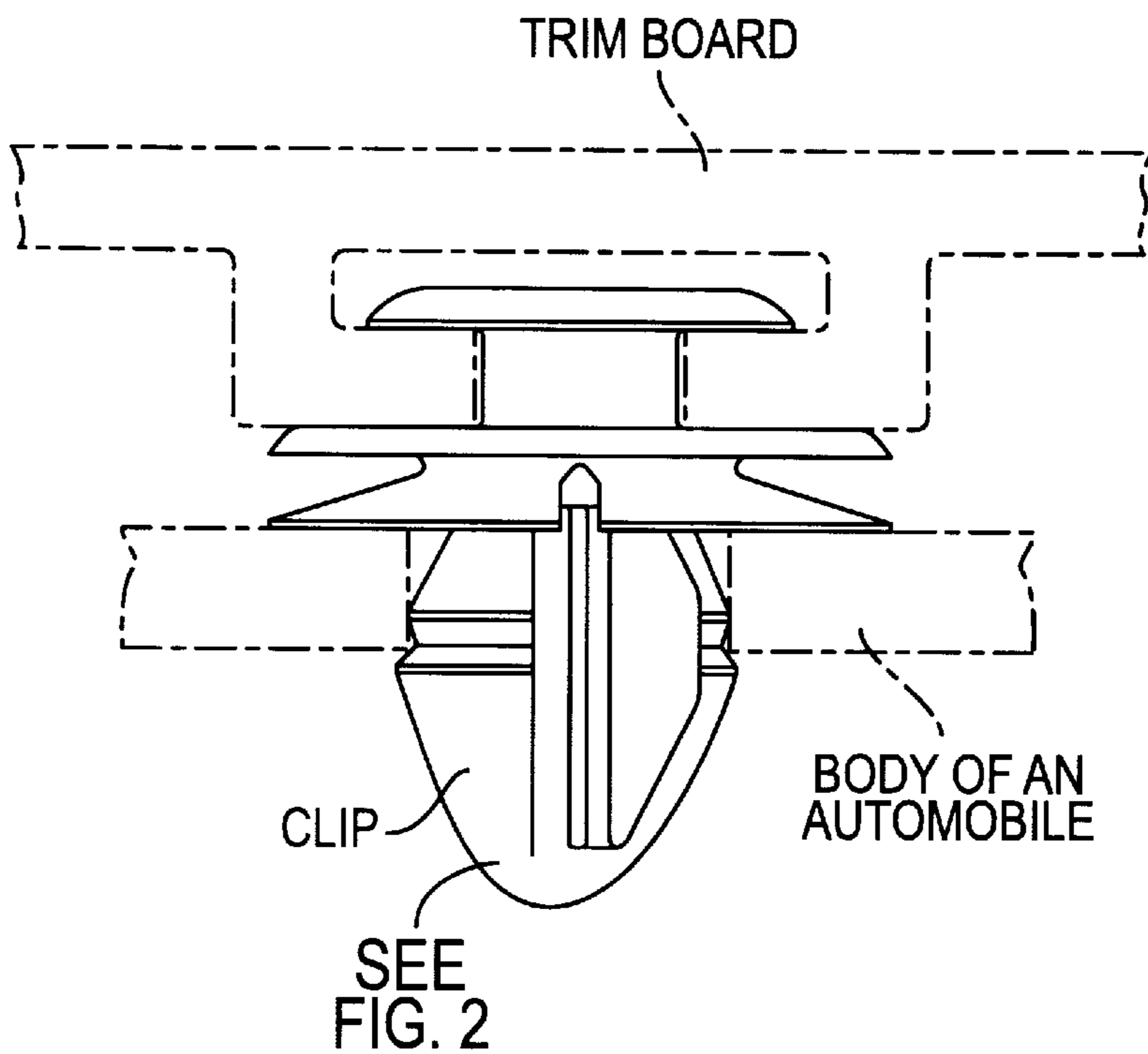

FIG. 9