



US00D456547S

(12) **United States Design Patent**
Leen

(10) **Patent No.:** **US D456,547 S**

(45) **Date of Patent:** **** Apr. 30, 2002**

(54) **SCALLOP STYLE LANDSCAPE LIGHT**

D395,726 S * 6/1998 Pink et al. D26/68

(76) Inventor: **Monte A. Leen**, 11730 NE. 12th St.,
Bellevue, WA (US) 98005

* cited by examiner

(**) Term: **14 Years**

Primary Examiner—Alan P. Douglas

Assistant Examiner—Linda Brooks

(74) *Attorney, Agent, or Firm*—Dean A. Craine

(21) Appl. No.: **29/137,643**

(57) **CLAIM**

(22) Filed: **Feb. 26, 2001**

The ornamental design for a scallop style landscape light, as shown and described.

(51) **LOC (7) Cl.** **26-05**

(52) **U.S. Cl.** **D26/67**

(58) **Field of Search** D26/67-71, 85-87,
D26/92-112; 362/183, 431, 153, 153.1,
276

DESCRIPTION

FIG. 1 is a perspective view of the scallop style landscape light.

FIG. 2 is a front elevation view of the invention.

FIG. 3 is a right side elevation view of the invention.

FIG. 4 is a top plan view of the invention; and,

FIG. 5 is a bottom plan view of the invention.

(56) **References Cited**

U.S. PATENT DOCUMENTS

D391,384 S * 2/1998 Lerch D26/67

1 Claim, 3 Drawing Sheets

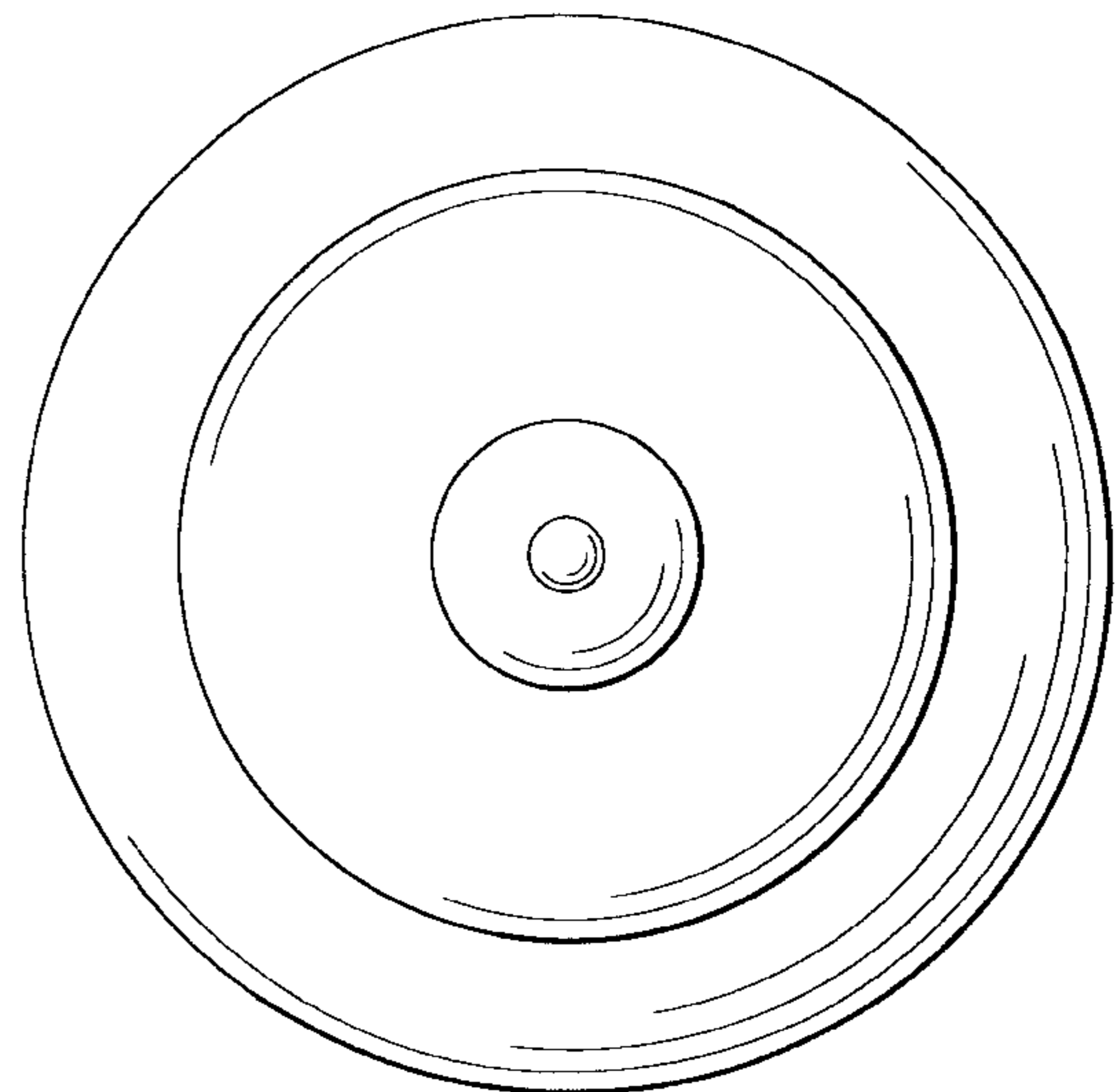
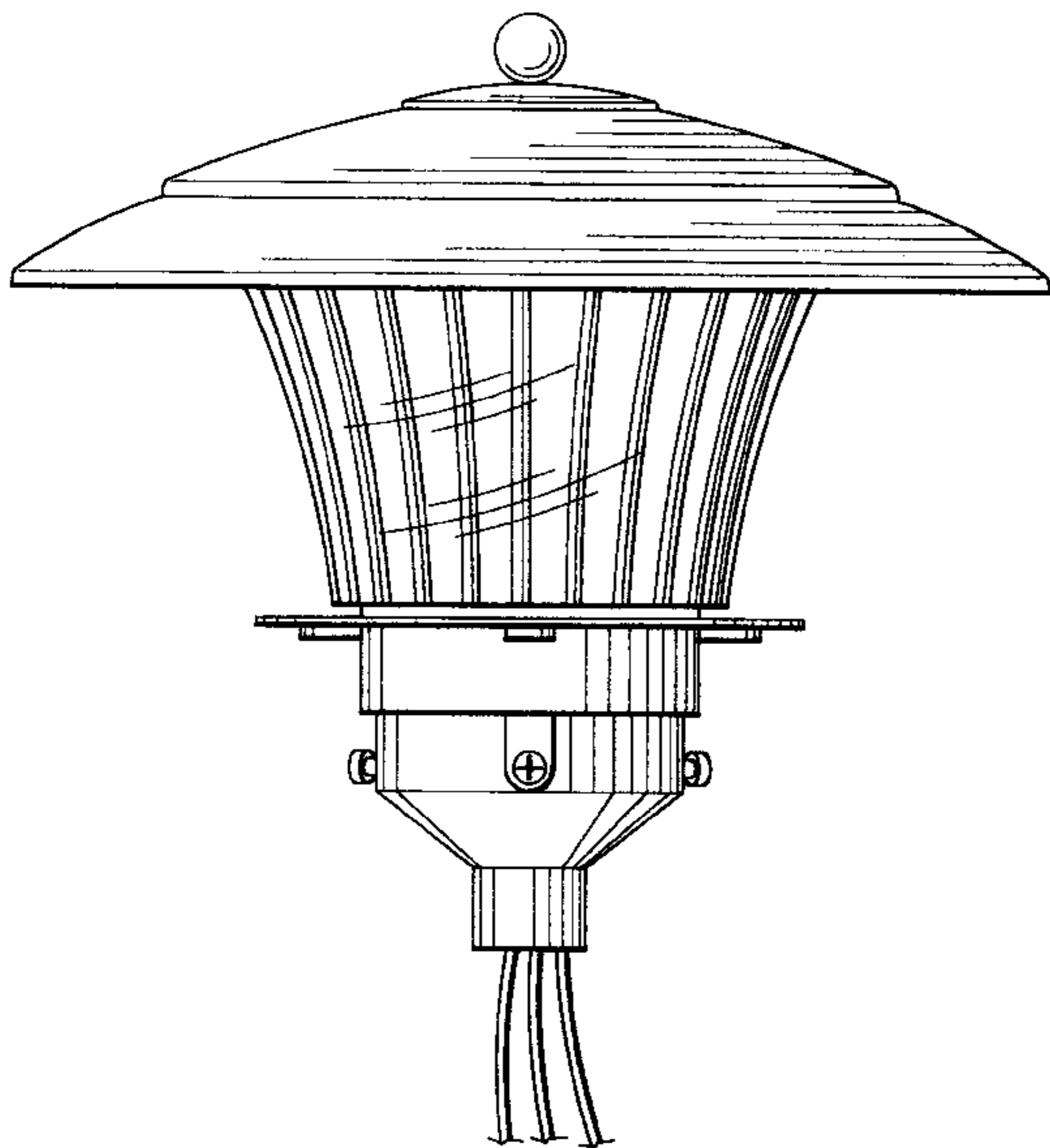

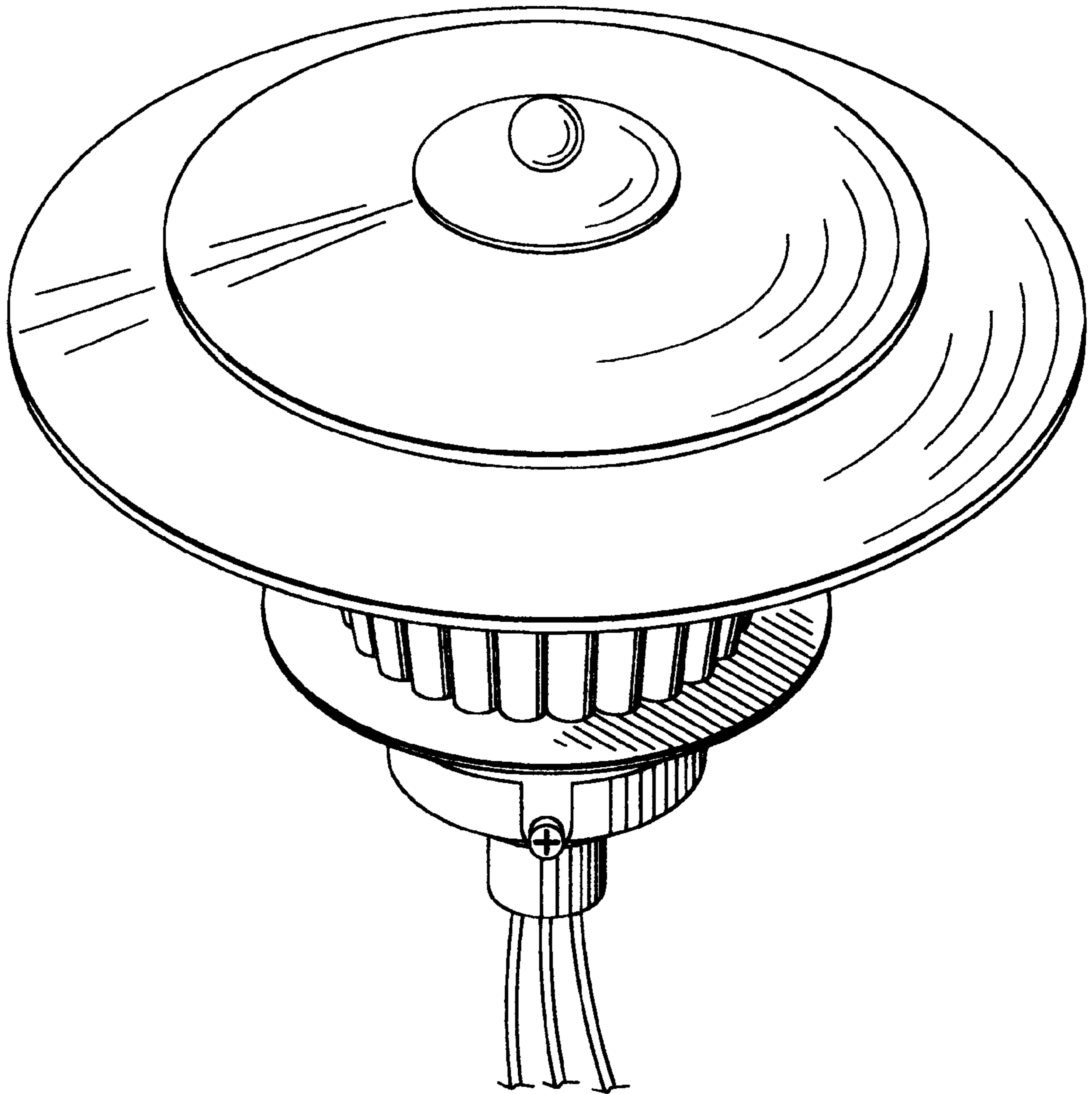
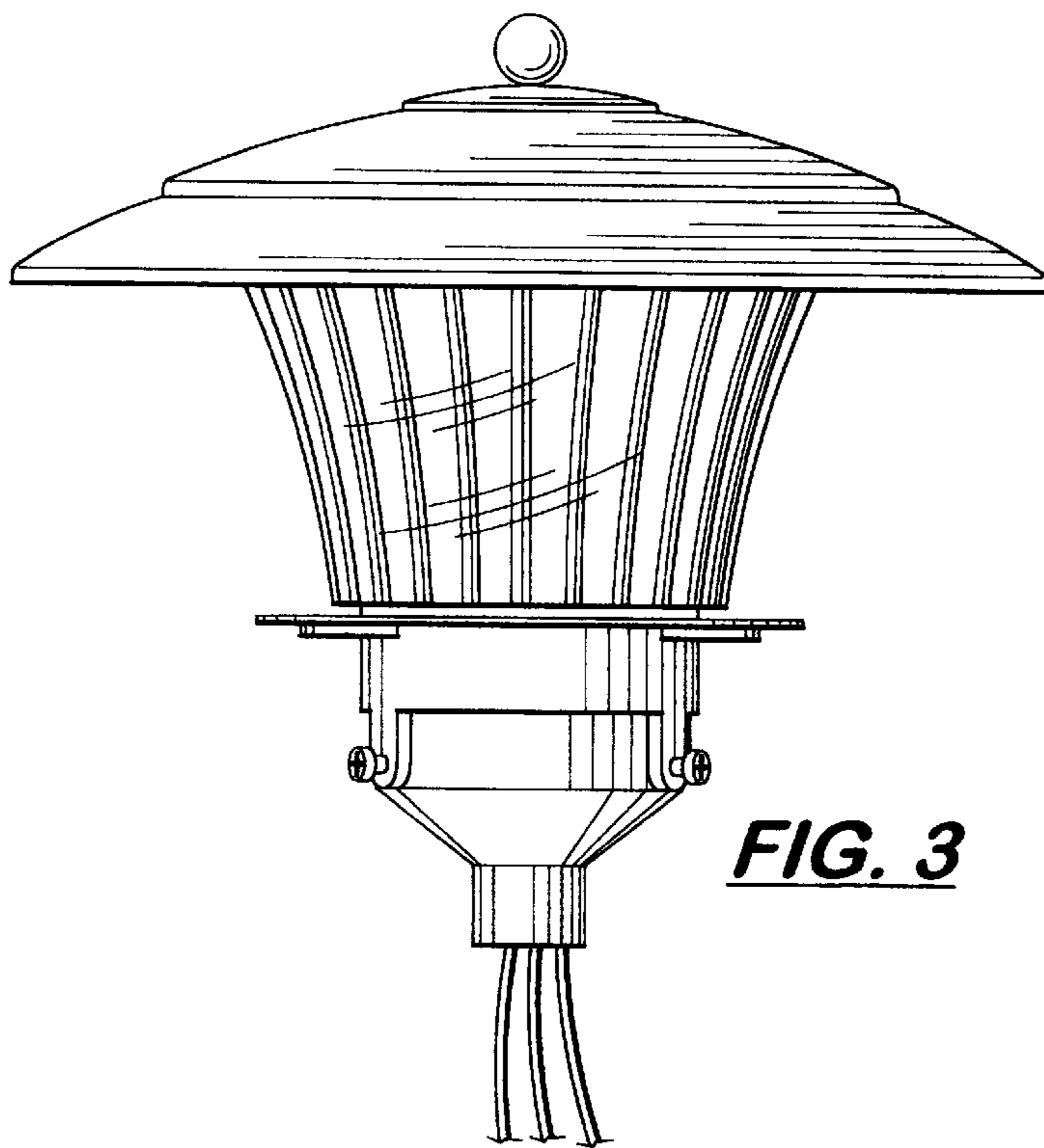
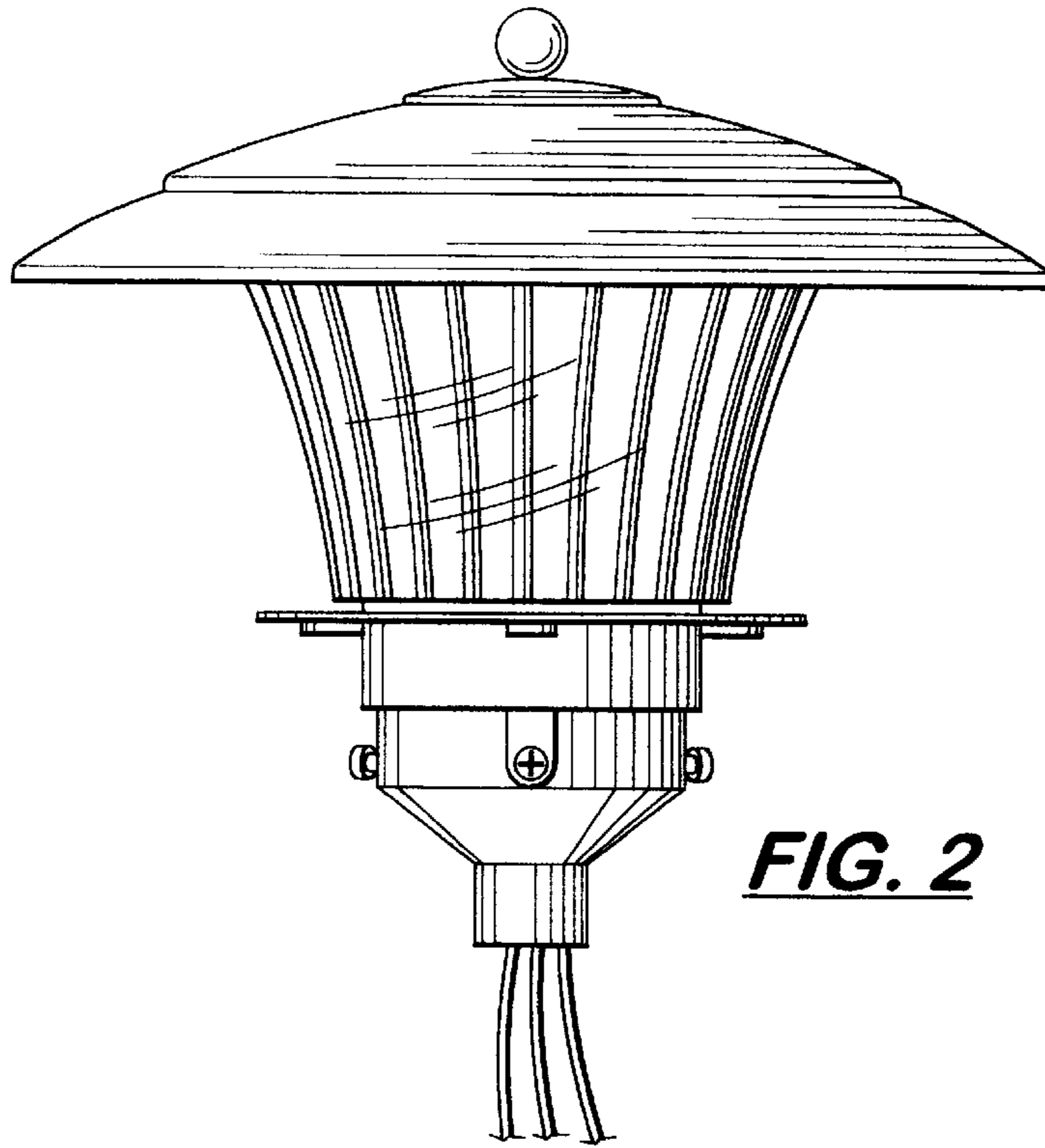

FIG. 1



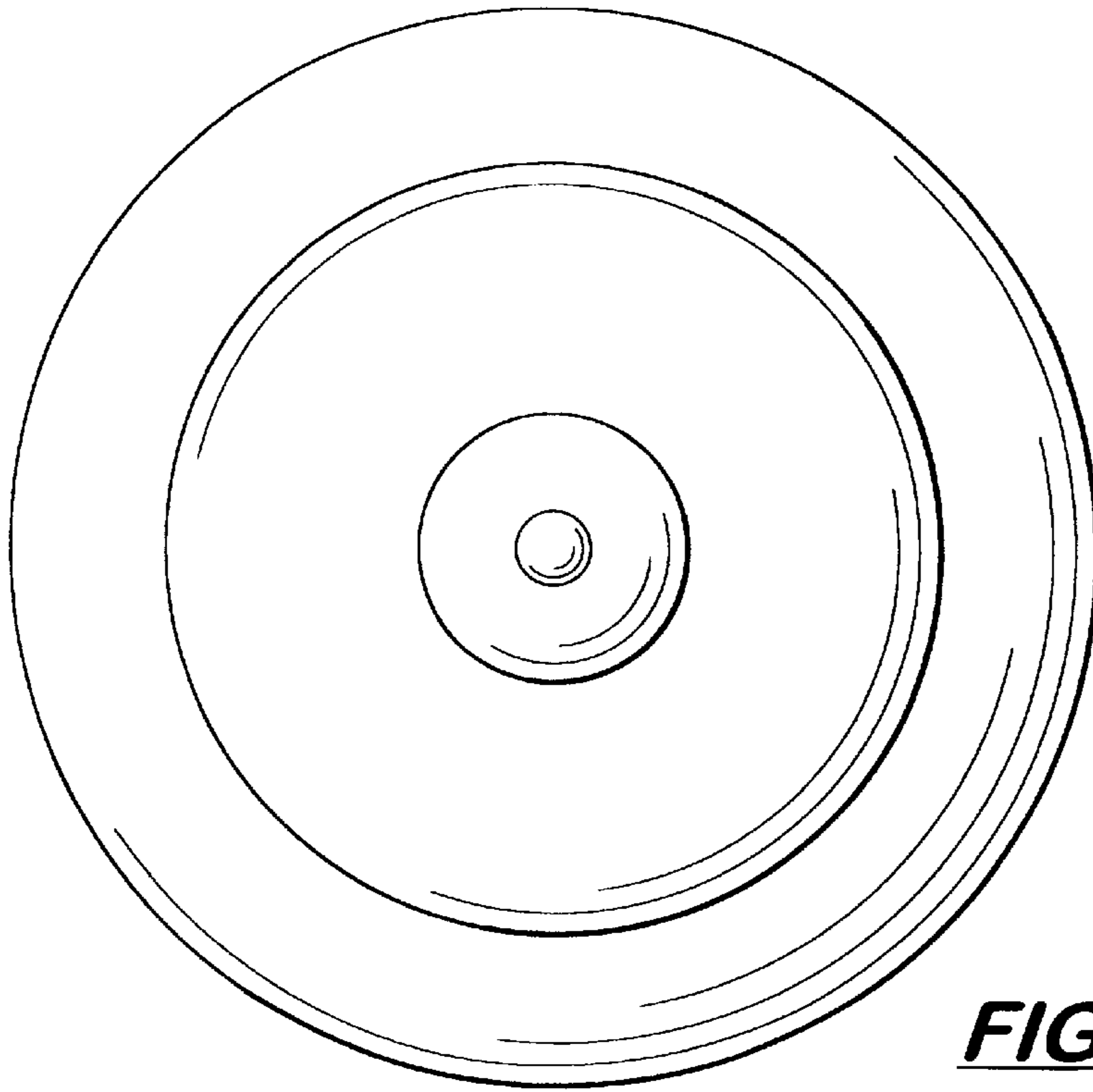

FIG. 4

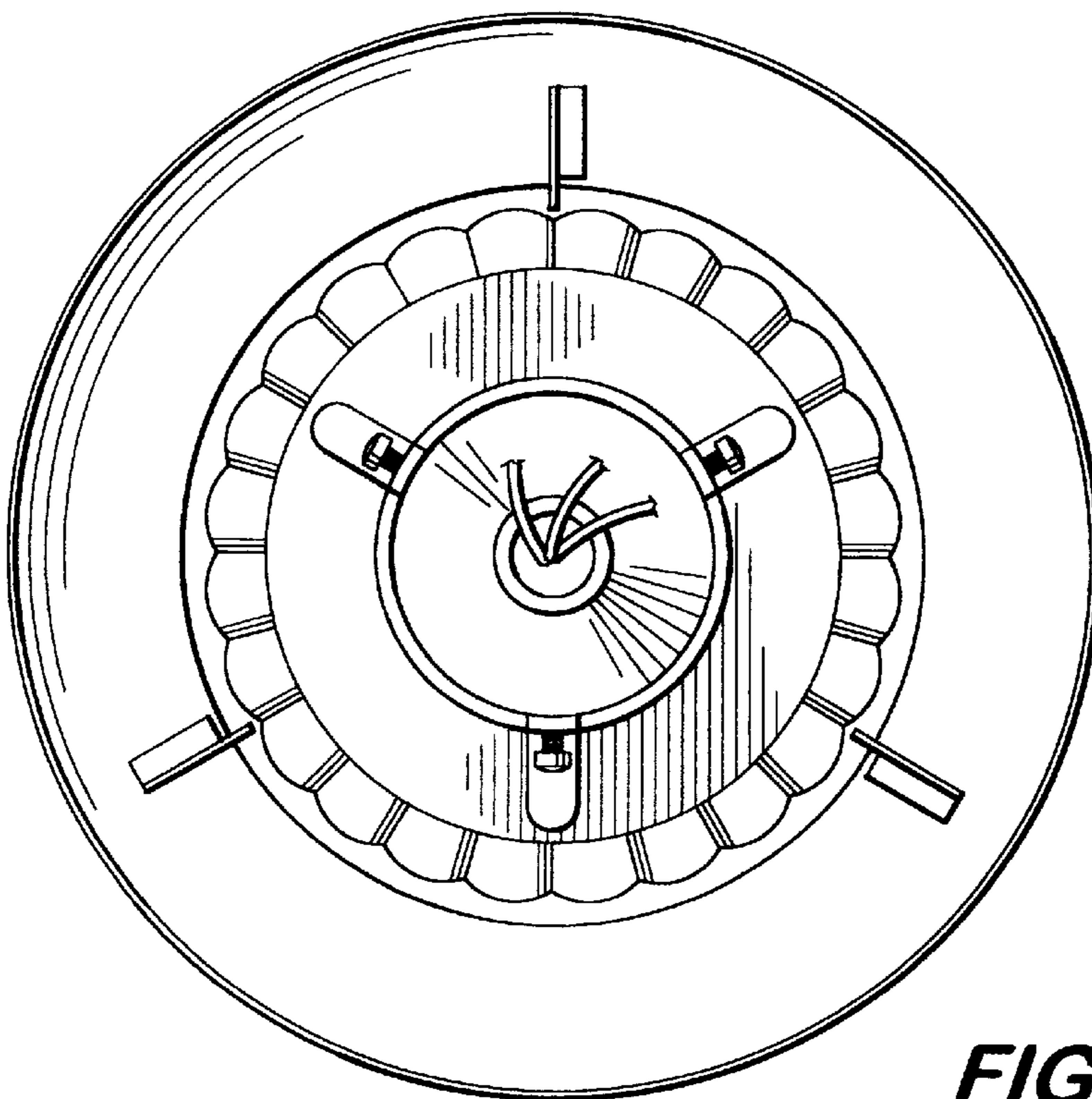

FIG. 5