



US00D456337S

(12) **United States Design Patent**
Sankrithi et al.

(10) **Patent No.:** **US D456,337 S**

(45) **Date of Patent:** **** Apr. 30, 2002**

(54) **BLENDED WING AND MULTIPLE BODY AIRPLANE CONFIGURATION**

D146,072 S * 12/1946 Bowers D12/342
D273,005 S * 3/1984 McComas D12/335

(75) Inventors: **Mithra M. K. V. Sankrithi**, Federal Way; **Steven J. Wald**; **Gary R. Thomas**, both of Seattle, all of WA (US)

* cited by examiner

Primary Examiner—Marcus A. Jackson
(74) *Attorney, Agent, or Firm*—Conrad O. Gardner

(73) Assignee: **The Boeing Company**, Seattle, WA (US)

(57) **CLAIM**

The ornamental design for a blended wing and multiple-body airplane configuration, as shown and described.

(**) Term: **14 Years**

DESCRIPTION

(21) Appl. No.: **29/139,037**

FIG. 1 is a top, front isometric view of the aircraft, with the broken line showing for illustrative purposes and forming no part of the claimed design;

(22) Filed: **Mar. 23, 2001**

FIG. 2 is a top plan view of the aircraft;

(51) **LOC (7) Cl.** **12-07**

(52) **U.S. Cl.** **D12/335**

(58) **Field of Search** D12/335, 338, D12/343, 344; 244/12.3

FIG. 3 is a bottom plan view of the aircraft;

FIG. 4 is a left side elevation view of the aircraft;

FIG. 5 is a right side elevation view of the aircraft;

FIG. 6 is a front elevation view of the aircraft; and,

FIG. 7 is a rear elevation view of the aircraft.

(56) **References Cited**

U.S. PATENT DOCUMENTS

D139,438 S * 11/1944 Hughes et al. D12/335

1 Claim, 3 Drawing Sheets

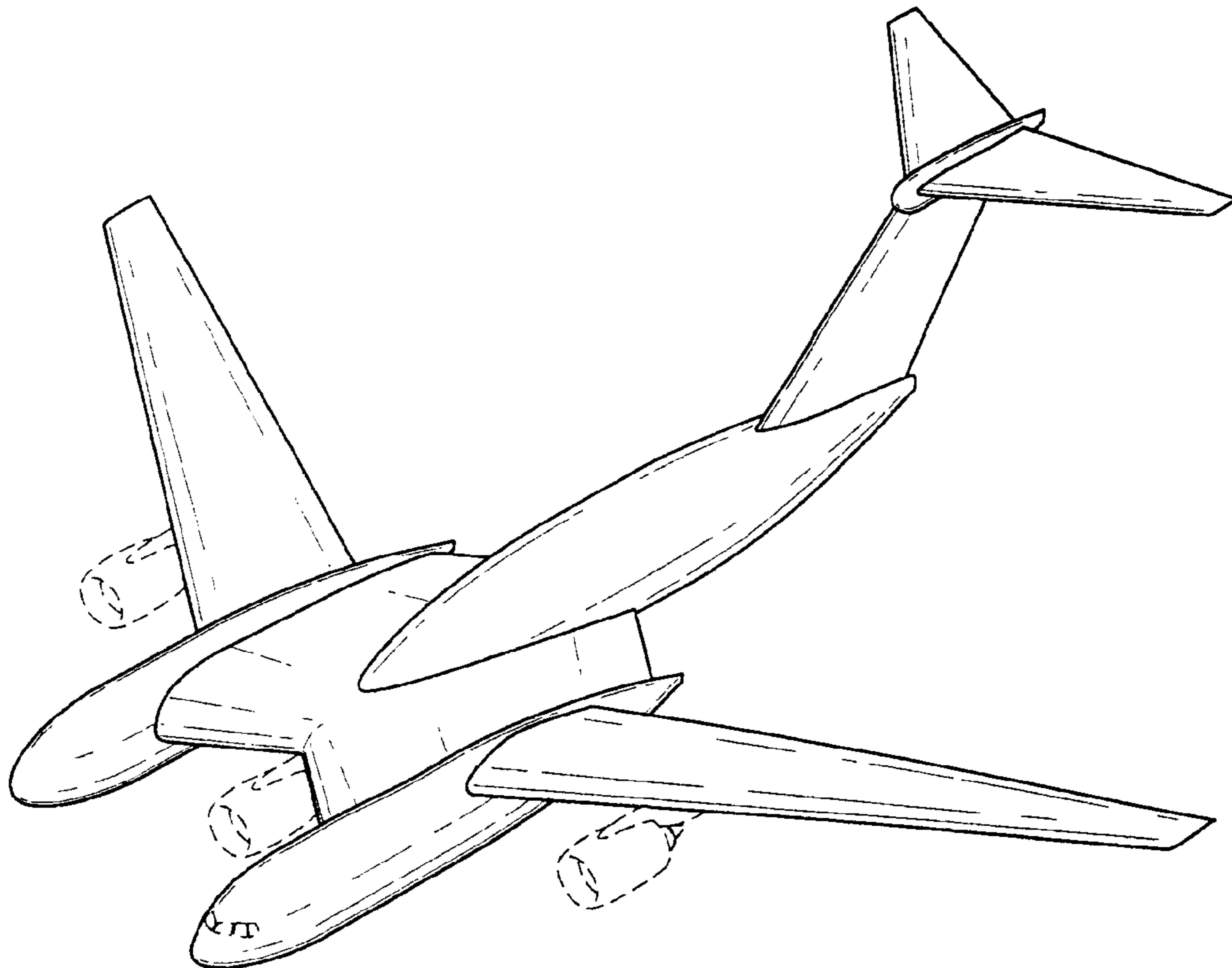

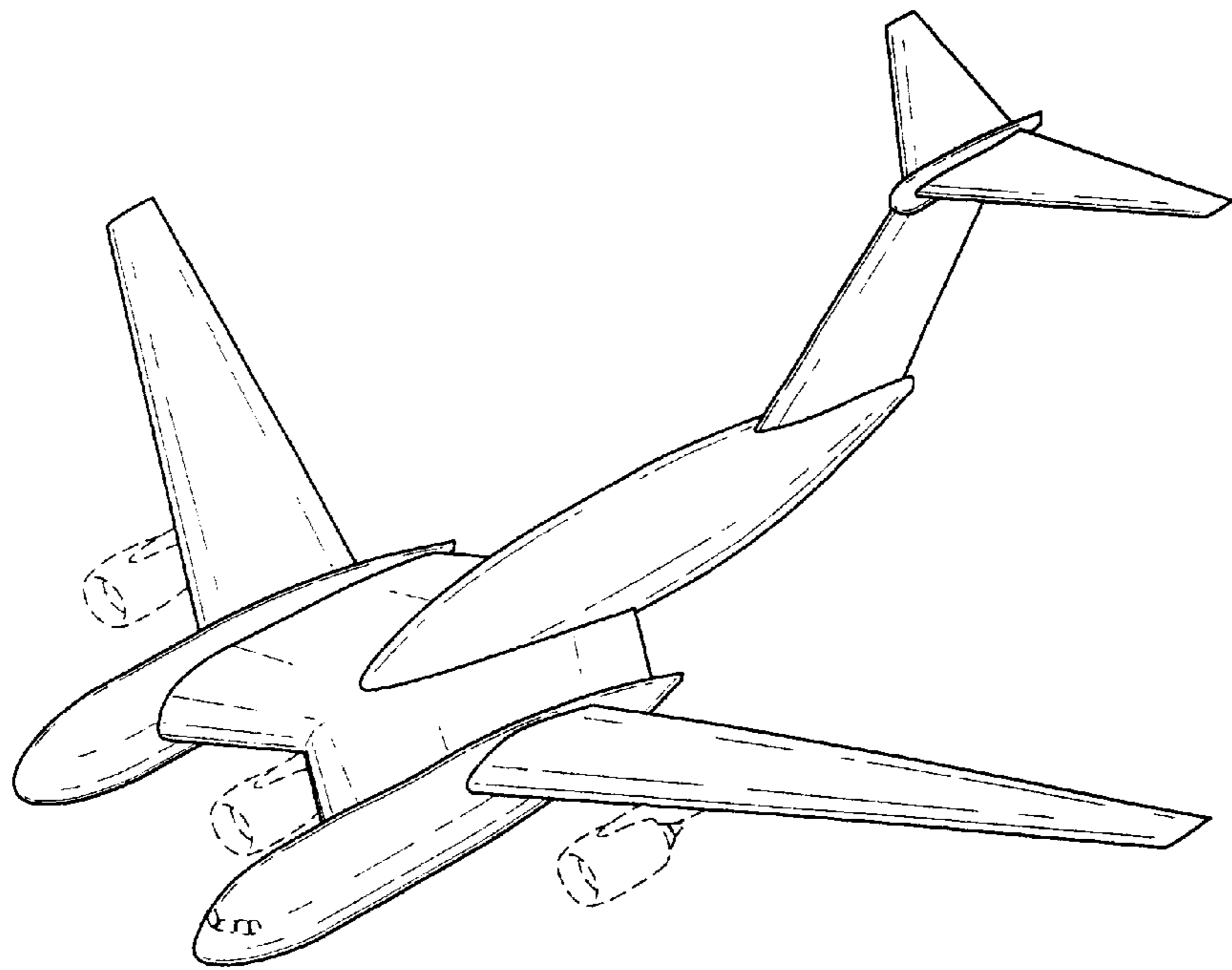

Fig. 1

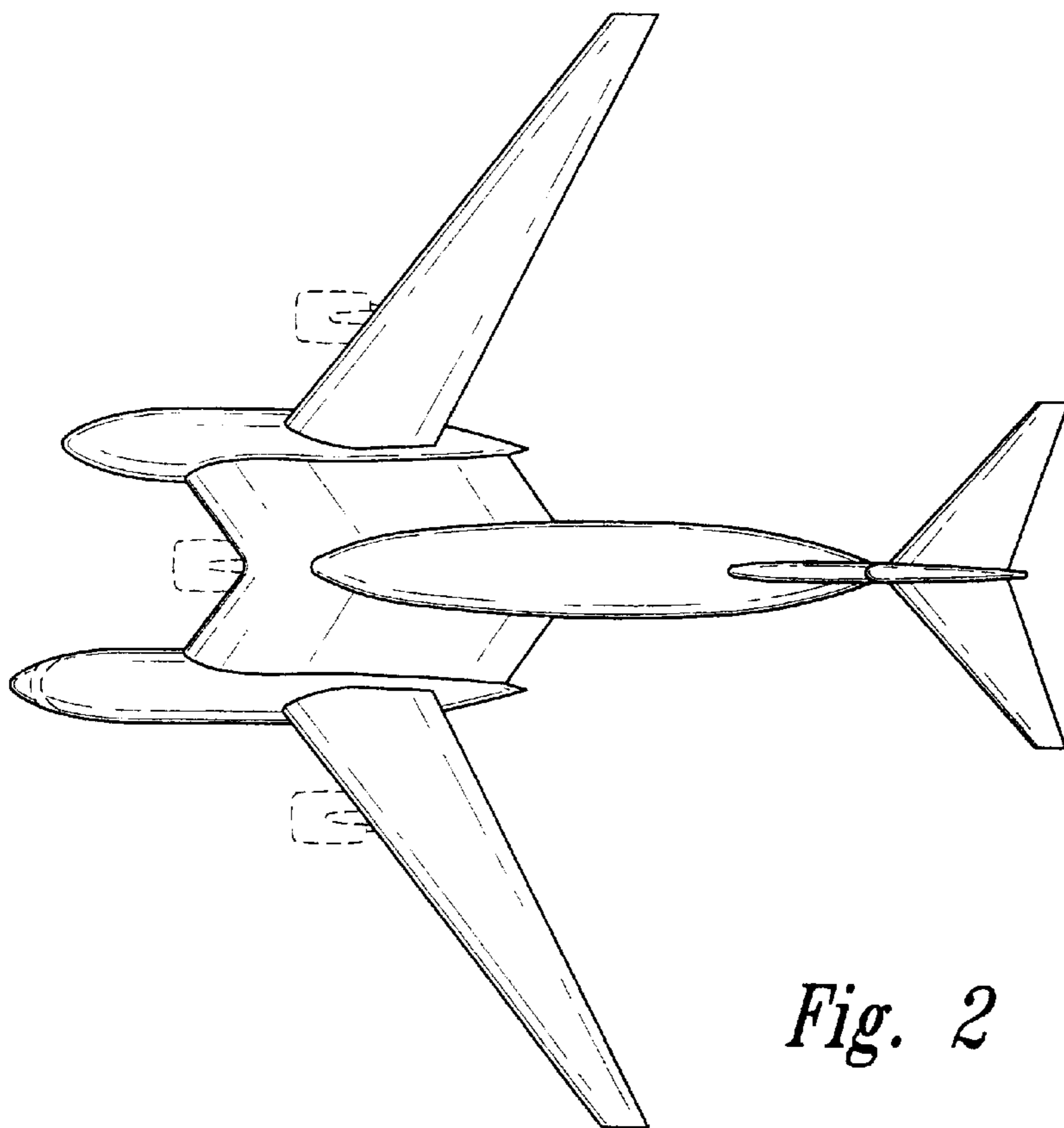

Fig. 2

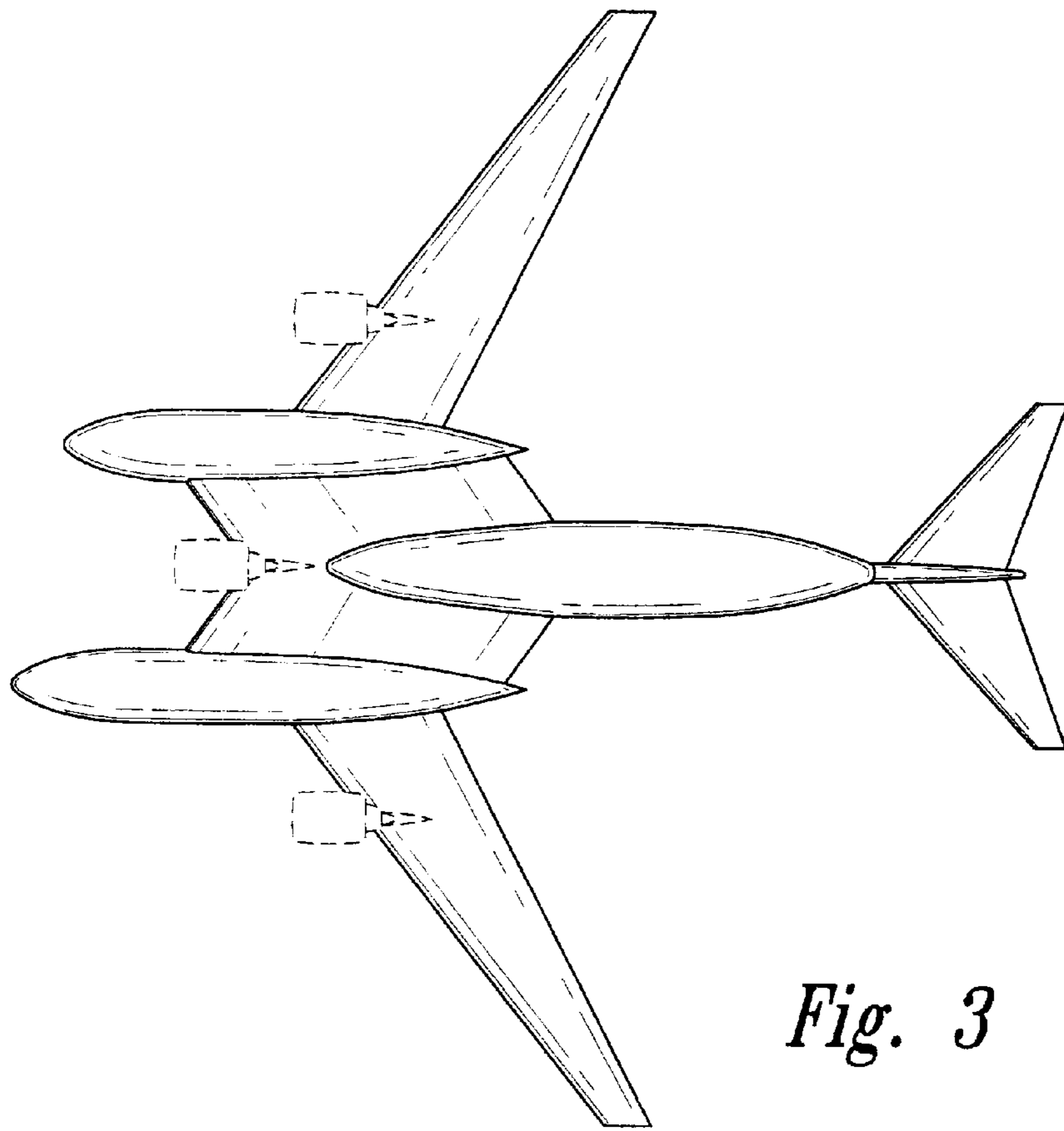

Fig. 3

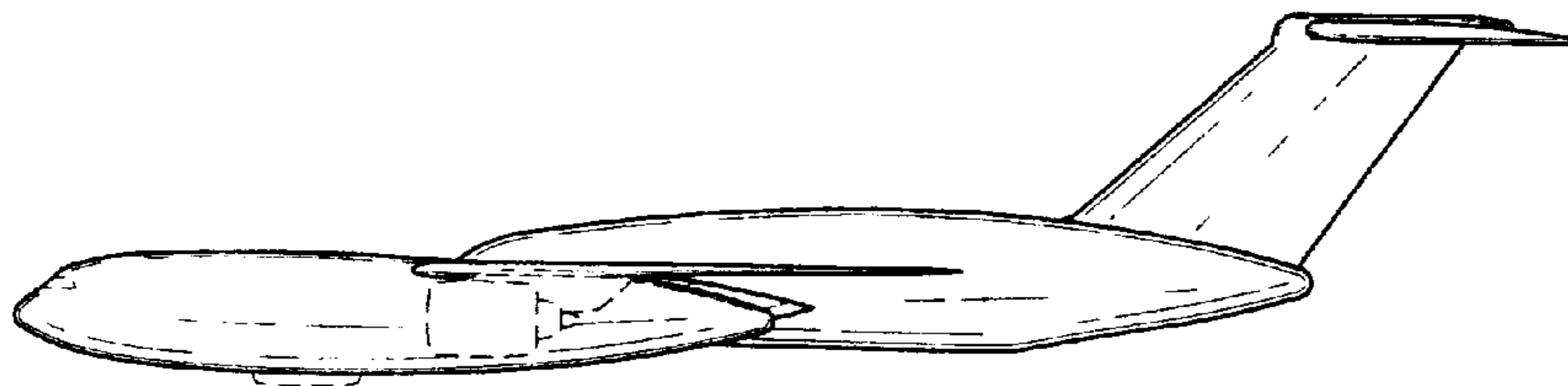

Fig. 4

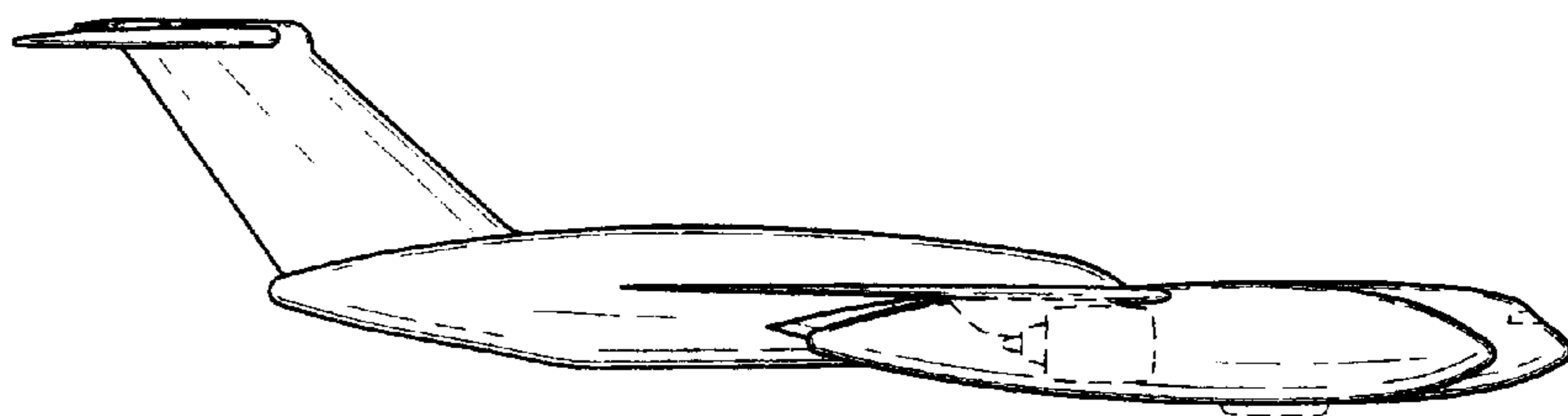

Fig. 5

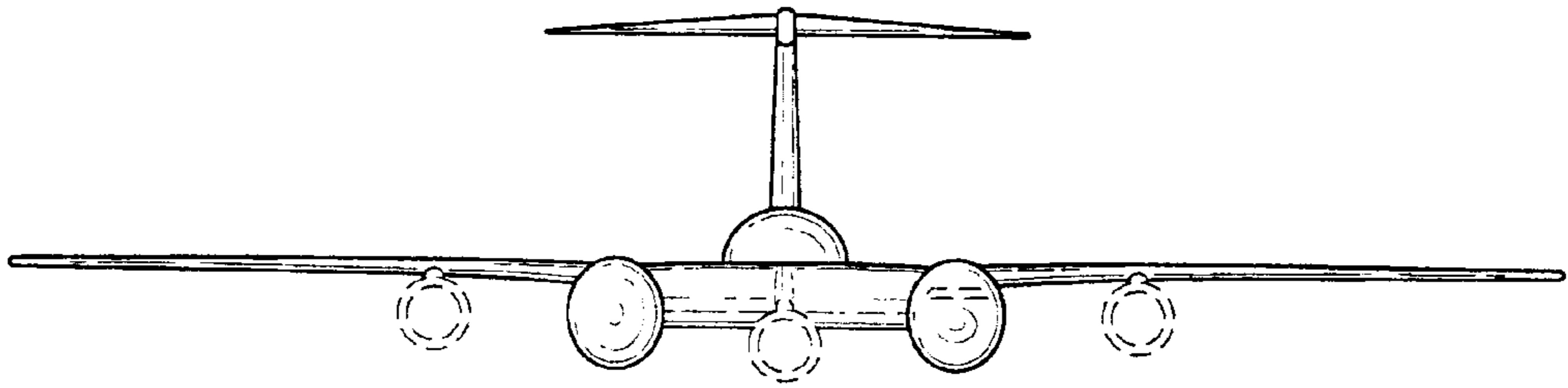

Fig. 6

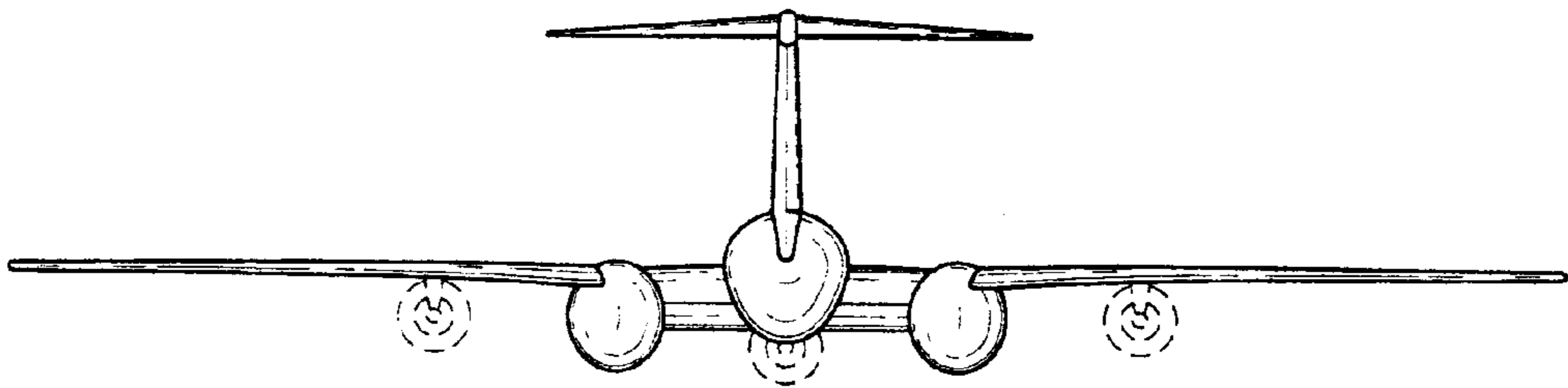

Fig. 7