



US00D456237S

(12) **United States Design Patent**  
**Sokurenko et al.**

(10) **Patent No.:** **US D456,237 S**

(45) **Date of Patent:** **\*\* Apr. 30, 2002**

(54) **SWELL LATCH**

D413,056 S 8/1999 Sokurenko et al.  
6,109,669 A \* 8/2000 Pinkow

(75) Inventors: **William E. Sokurenko**, Glen Mills;  
**Eric D. Hyp**, Aspers, both of PA (US)

**FOREIGN PATENT DOCUMENTS**

(73) Assignee: **Southco, Inc.**, Concordville, PA (US)

EP 480534 A1 4/1992

(\*\*) Term: **14 Years**

**OTHER PUBLICATIONS**

(21) Appl. No.: **29/123,586**

(22) Filed: **May 19, 2000**

(51) **LOC (7) Cl.** ..... **08-06**

(52) **U.S. Cl.** ..... **D8/307; D8/306**

(58) **Field of Search** ..... D8/300–302, 306,  
D8/321, 331, 338, 341, 307; 292/113, 66,  
336.3, 257, 256.75, DIG. 36, DIG. 49,  
DIG. 60

Southco Handbook 2000, “Push to Close Latch” pp. 108 and 109, 2000, Pennsylvania 19331.\*

Southco Fasteners Handbook 40, “Swell Latches”, p. J3, 1990, Pennsylvania 19331.\*

Southco Fasteners Handbook 40, “Swell Latches” p. J2, 1990, Pennsylvania, 19331.

Southco Fasteners handbook 40, “Fractional–Turn Fastener”, p. J12, 1990, Pennsylvania, 19331.

\* cited by examiner

*Primary Examiner*—B. J. Bullock

(74) *Attorney, Agent, or Firm*—Paul & Paul

(56) **References Cited**

**U.S. PATENT DOCUMENTS**

- 1,931,850 A 10/1933 Moore
- 2,094,779 A 10/1937 Donaldson
- 2,319,504 A 5/1943 Holtman
- 2,691,543 A 10/1954 Morand
- 3,429,199 A 2/1969 Kenyon
- 3,847,423 A 11/1974 Gley
- 4,540,206 A 9/1985 Frame et al.
- 4,729,584 A 3/1988 Beckerer, Jr.
- D324,636 S \* 3/1992 Schlack et al.
- 5,127,684 A 7/1992 Klotz et al.
- D352,885 S 11/1994 Holtman
- 5,368,347 A 11/1994 Holtman et al.
- D357,395 S \* 4/1995 Ziemer et al.
- D370,620 S \* 6/1996 Ziemer
- 5,590,921 A 1/1997 Holtman et al.

(57) **CLAIM**

I claim the ornamental design for a swell latch, as shown and described.

**DESCRIPTION**

FIG. 1 is a perspective view of the swell latch of the present invention.

FIG. 2 is a top plan view of the swell latch of FIG. 1.

FIG. 3 is a side view of the swell latch of FIG. 1.

FIG. 4 is a front view of the swell latch of FIG. 1.

FIG. 5 is the back view of the swell latch of FIG. 4; and,

FIG. 6 is a bottom view of the swell latch of FIG. 1.

**1 Claim, 1 Drawing Sheet**

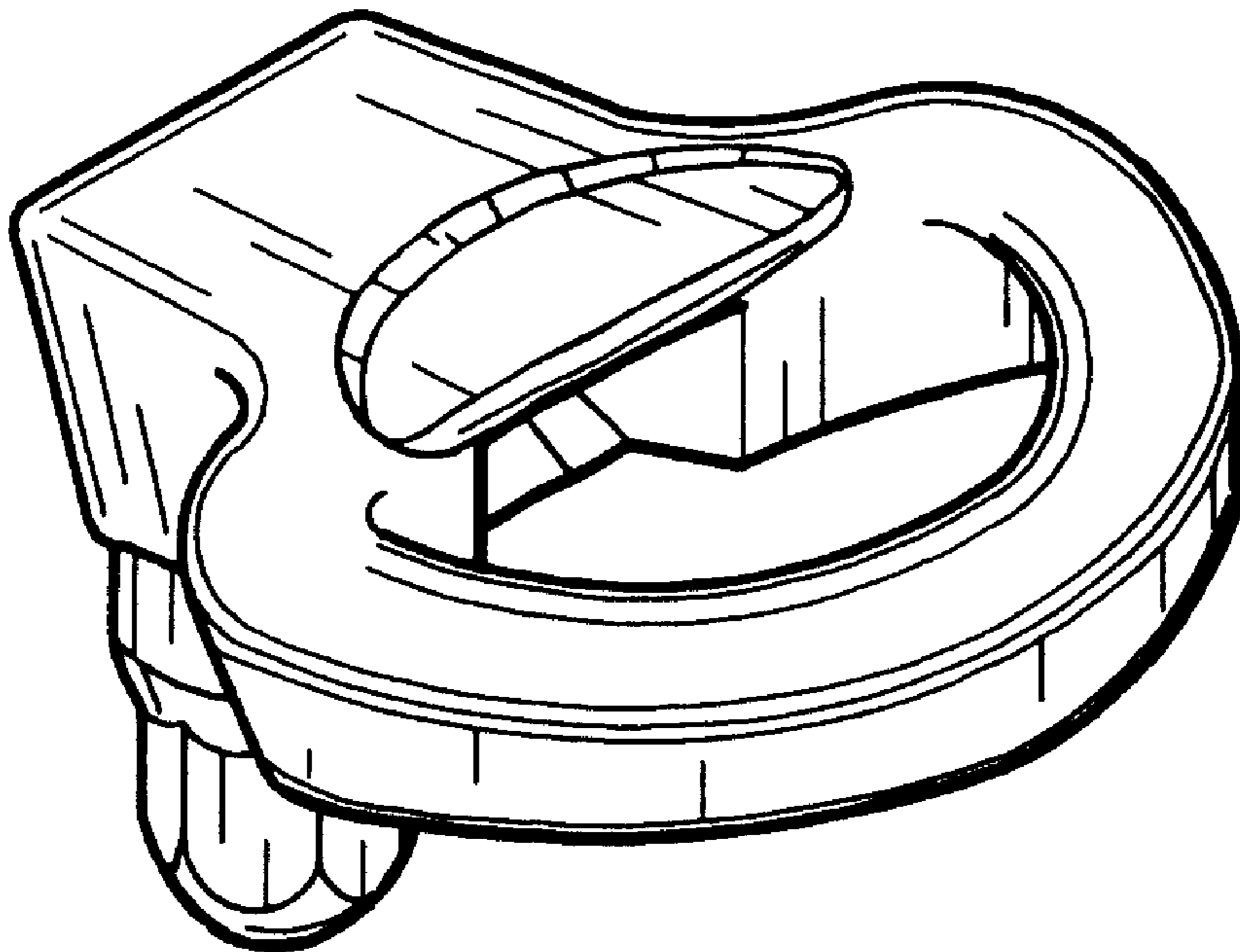

FIG. 1

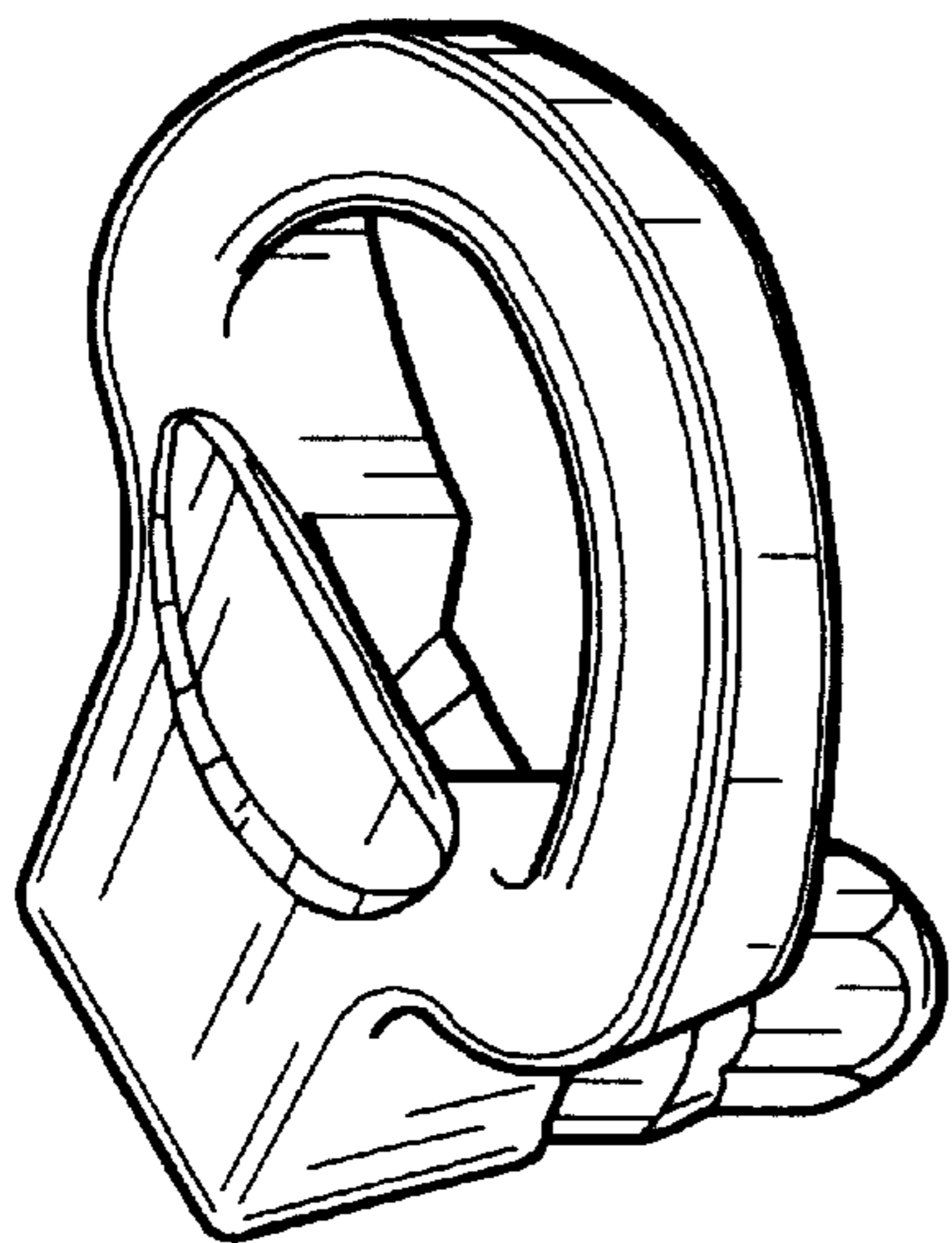

FIG. 2

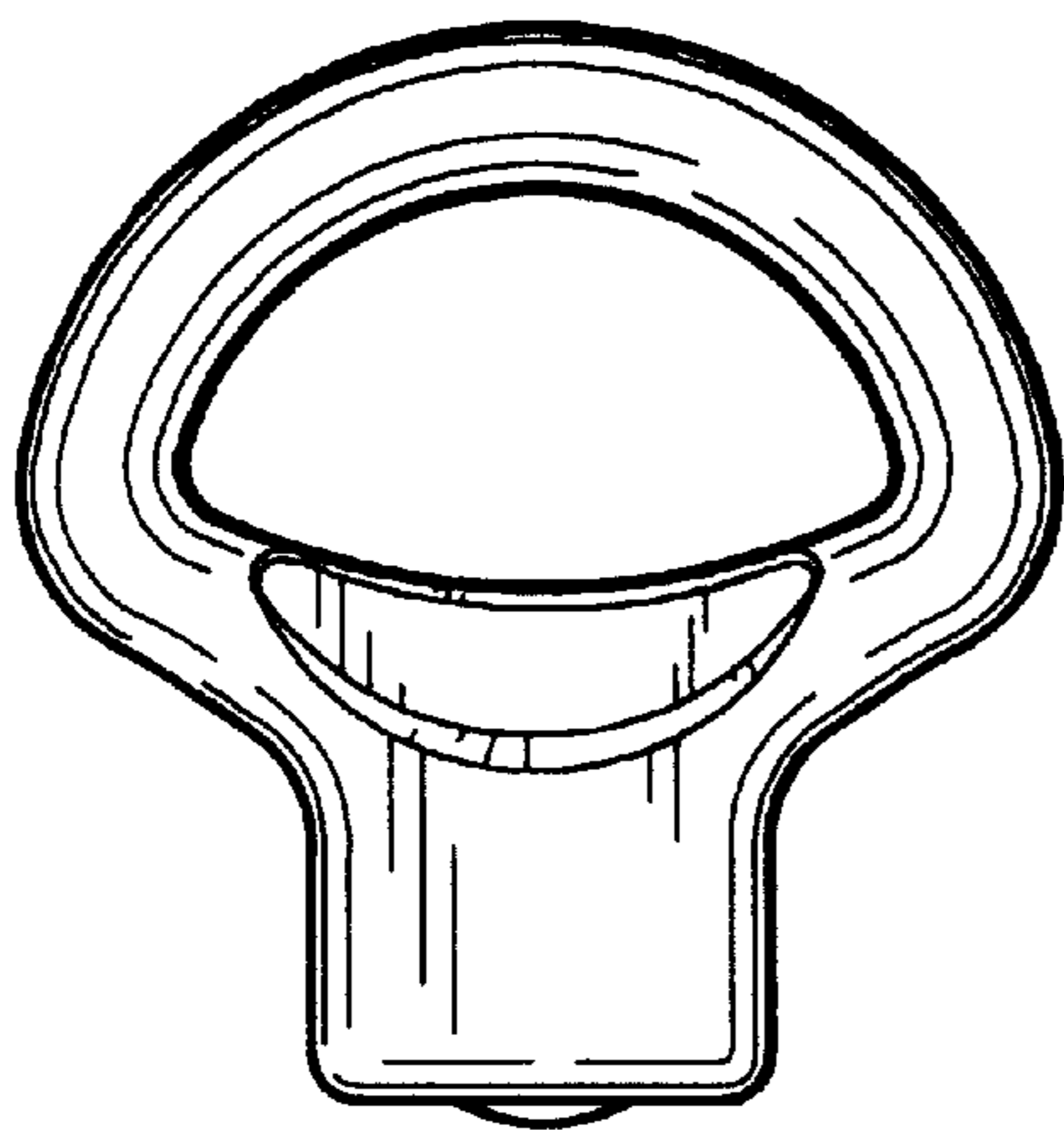

FIG. 3

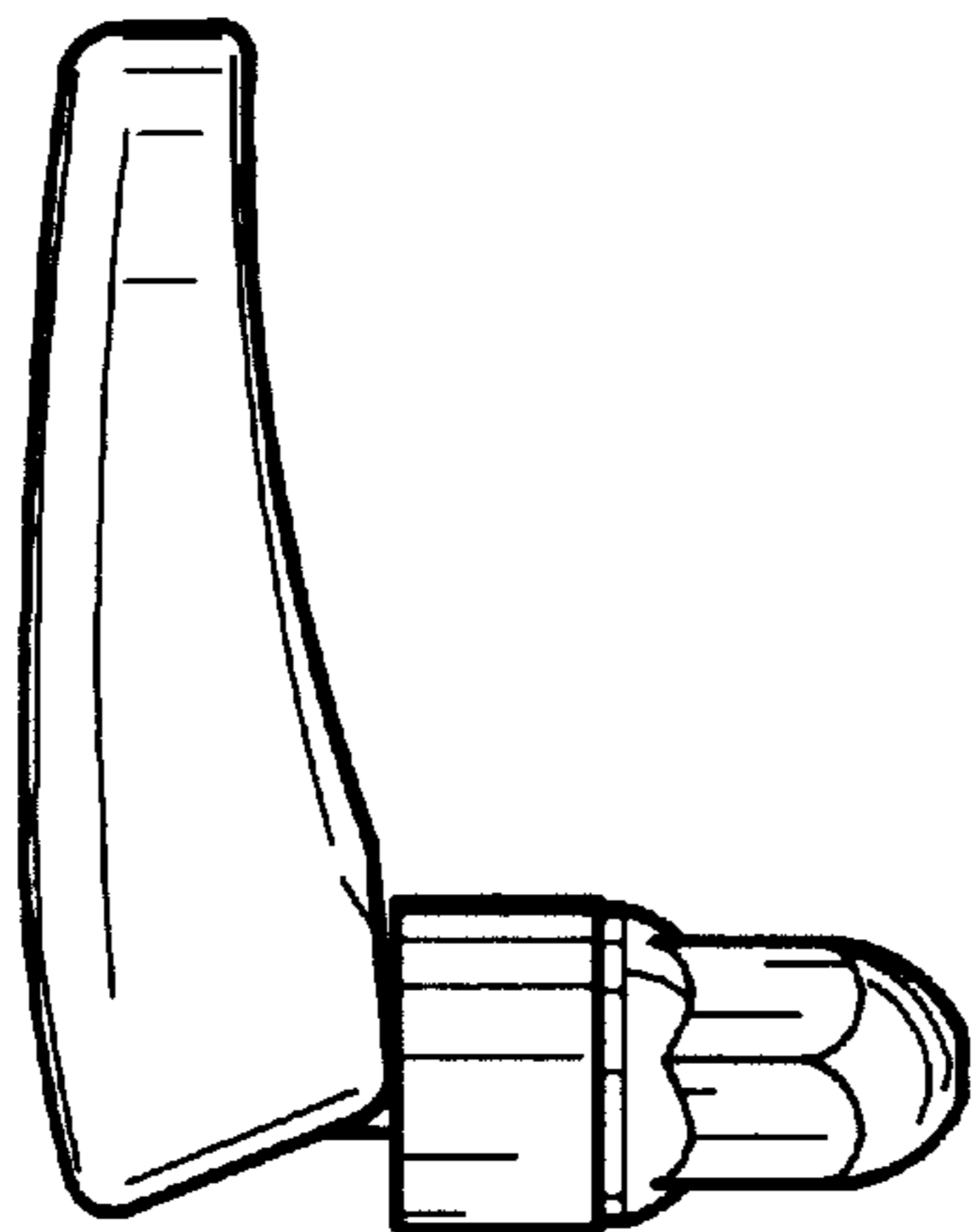

FIG. 4

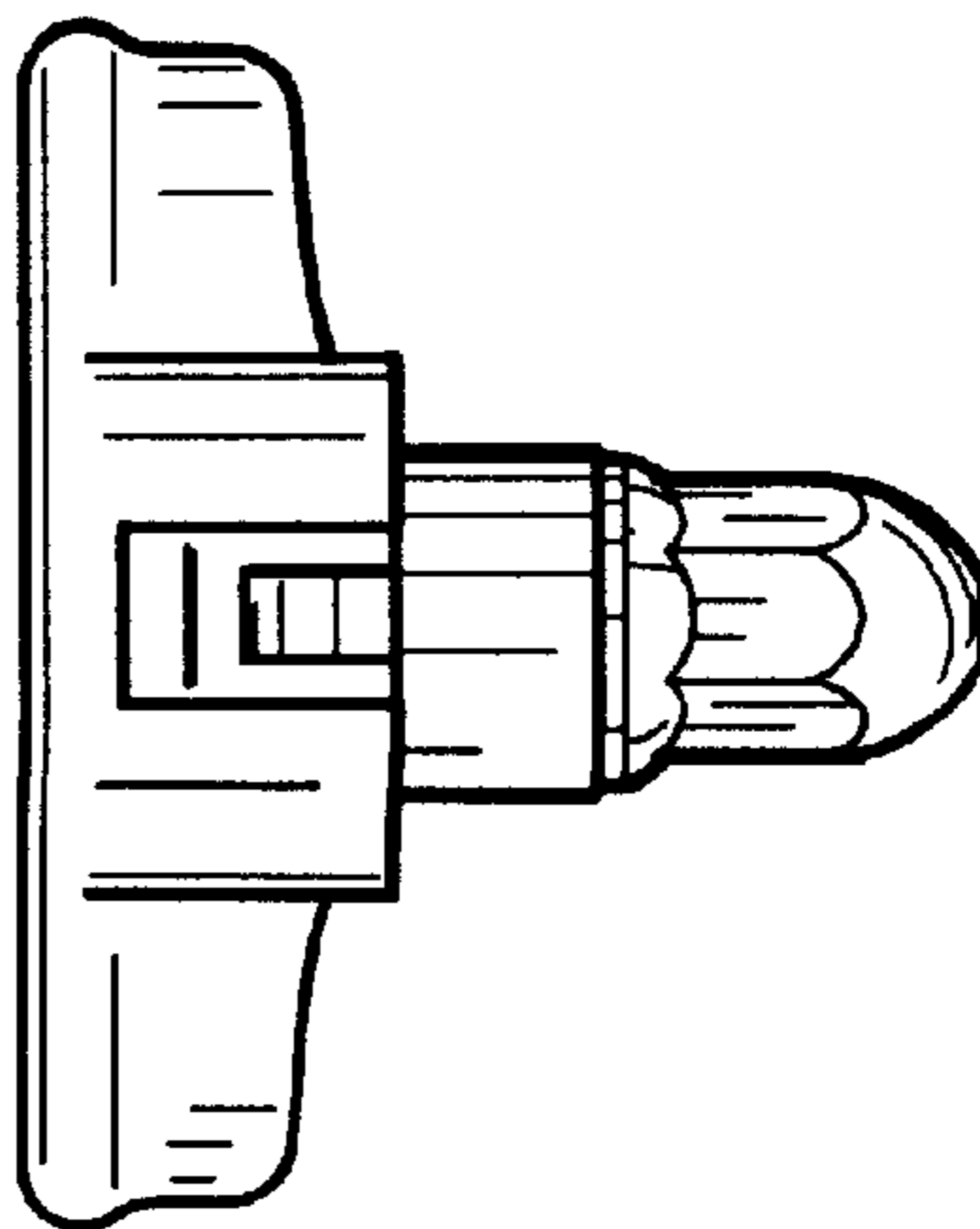

FIG. 5

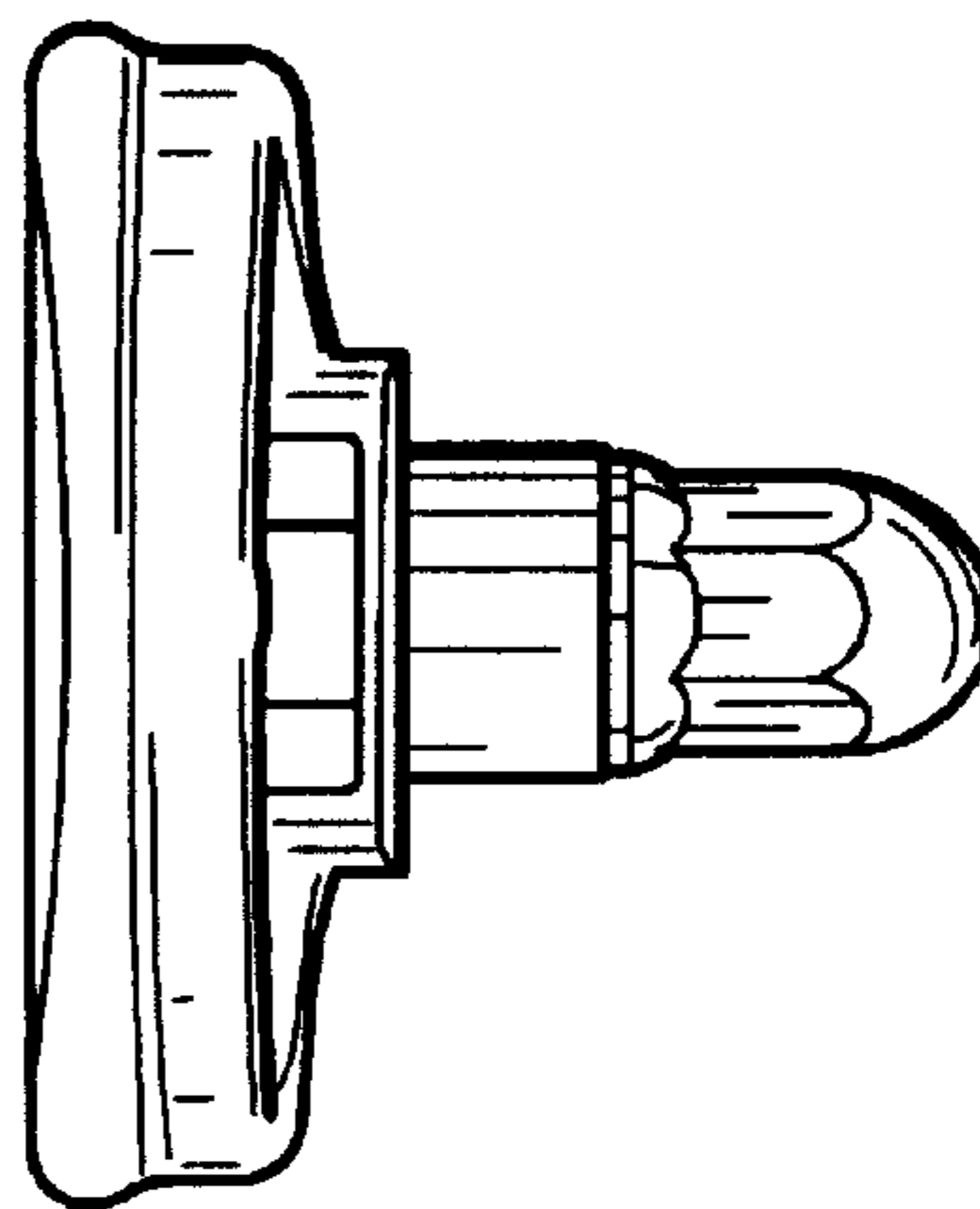

FIG. 6

