



US00D456085S

(12) **United States Design Patent**  
**O'Brien**

(10) **Patent No.: US D456,085 S**

(45) **Date of Patent: \*\* \*Apr. 23, 2002**

(54) **SERVICE STATION CANOPY**

(75) Inventor: **Michael J. O'Brien**, Naperville, IL (US)

(73) Assignee: **BP p.l.c.**, London (GB)

(\* ) Notice: This patent is subject to a terminal disclaimer.

(\*\* ) Term: **14 Years**

(21) Appl. No.: **29/126,735**

(22) Filed: **Jul. 21, 2000**

(51) **LOC (7) Cl.** ..... **25-02**

(52) **U.S. Cl.** ..... **D25/56**

(58) **Field of Search** ..... D25/56; 135/87, 135/88.01, 90, 121, 908, 115; 52/90.1, 91.1, 23

(56) **References Cited**

**U.S. PATENT DOCUMENTS**

3,143,827	A	*	8/1964	Showalter, Sr.	.....	D25/56
D302,820	S	*	8/1989	Bass	.....	D25/56
D402,771	S	*	12/1998	Broudy	.....	D25/56
D403,083	S	*	12/1998	Poelvoorde et al.	.....	D25/56

**OTHER PUBLICATIONS**

Existing Amoco Station, Landor, Nov. 18, 1999.  
BP Oil Europe Mobile Network Reimaging Level Of Treatment, M1/1R, Dec. 1996.

BP Oil Europe Mobil Network Reimaging Level of Treatment, M5, Dec. 1996.

BP Oil Retail Visual Standards, Level 1, revised 1998.

BP Oil Retail Visual Standards, Level 2, revised 1998.

BP Oil Retail Visual Standards, Level 4, revised 1998.

\* cited by examiner

*Primary Examiner*—Doris Clark

(74) *Attorney, Agent, or Firm*—Thomas W. Tolpin; Ekkehard Schoettle

(57) **CLAIM**

The ornamental design for a service station canopy, substantially as shown and described.

**DESCRIPTION**

FIG. 1 is a perspective view of a service station canopy in accordance with the present design;

FIG. 2 is a side elevational view of the service station canopy of FIG. 1;

FIG. 3 is a front elevational view of the service station canopy of FIG. 1;

FIG. 4 is a top plan view of the service station canopy of FIG. 1; and,

FIG. 5 is a bottom plan view of the service station canopy of FIG. 1.

All broken lines illustrated in the drawings designate environmental structure.

**1 Claim, 3 Drawing Sheets**

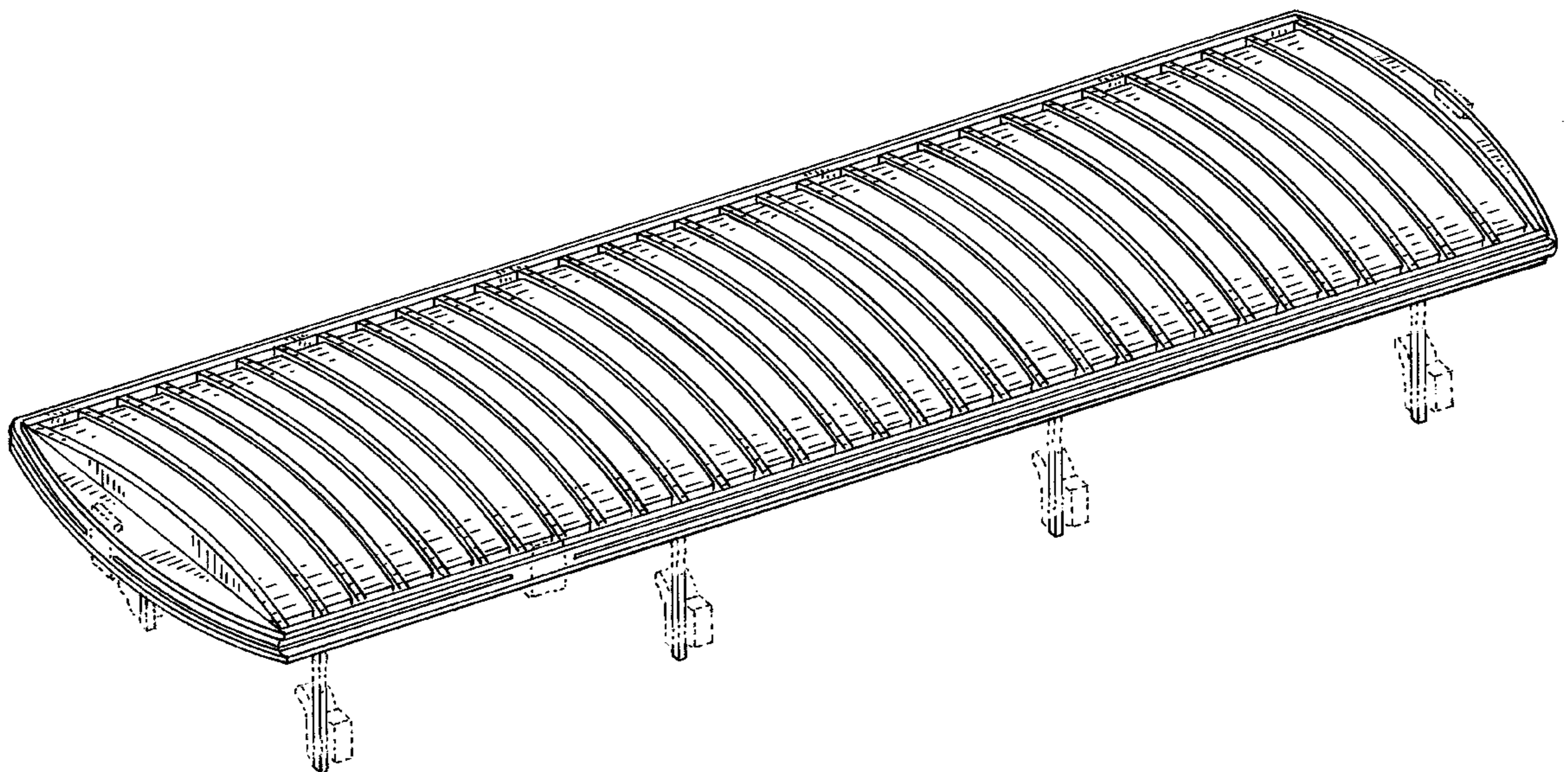

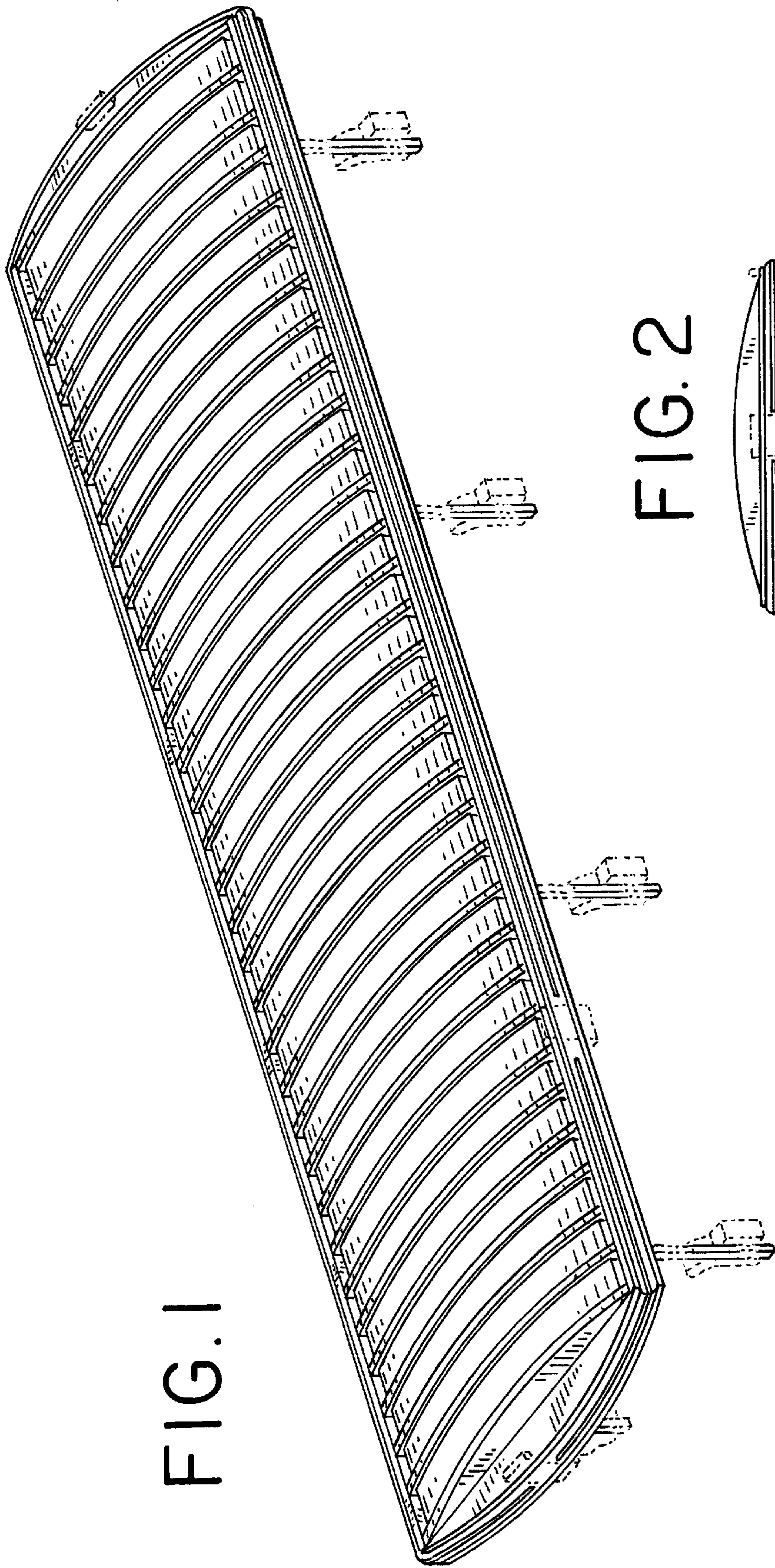

FIG. 2

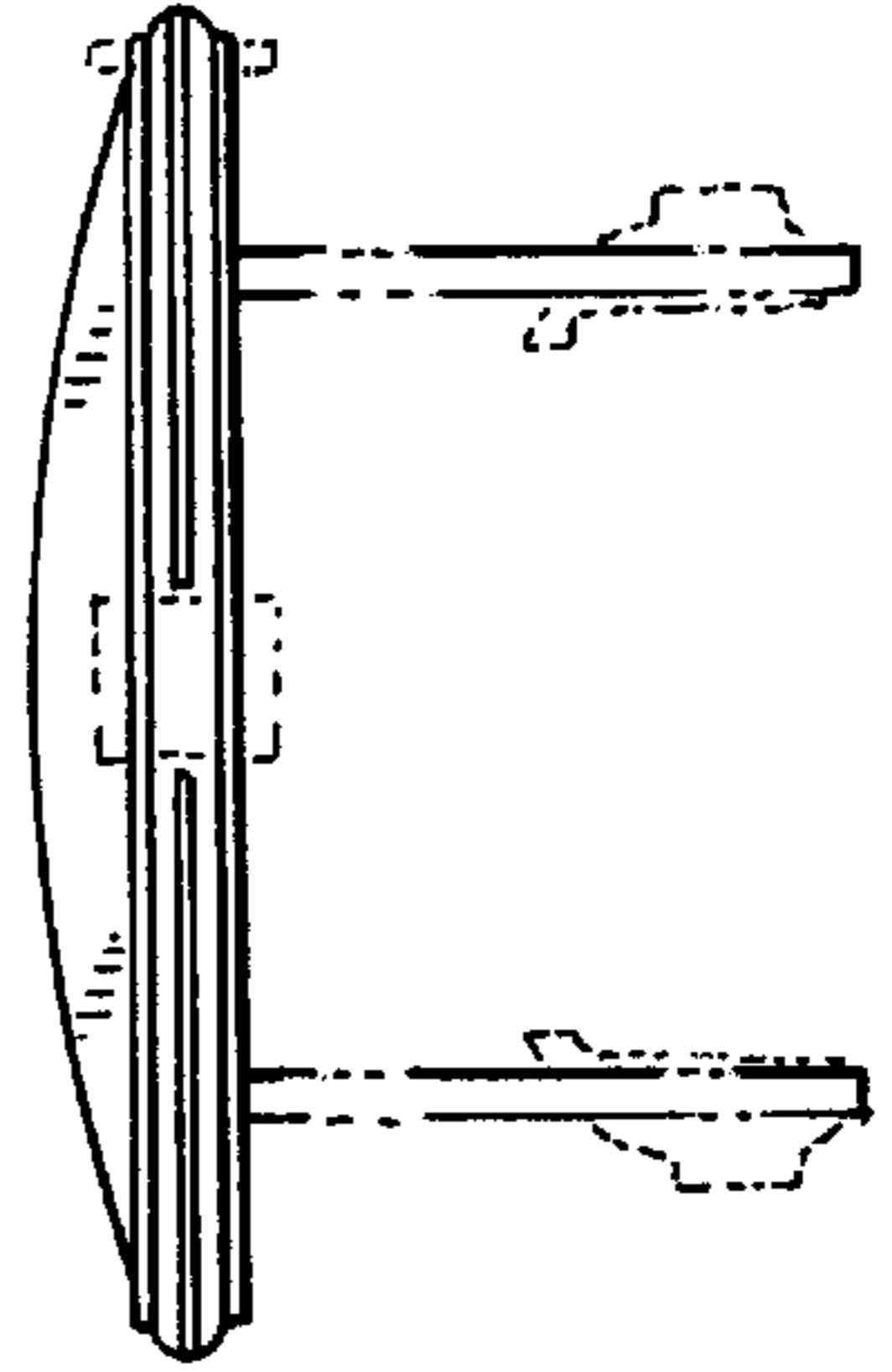

FIG. 3

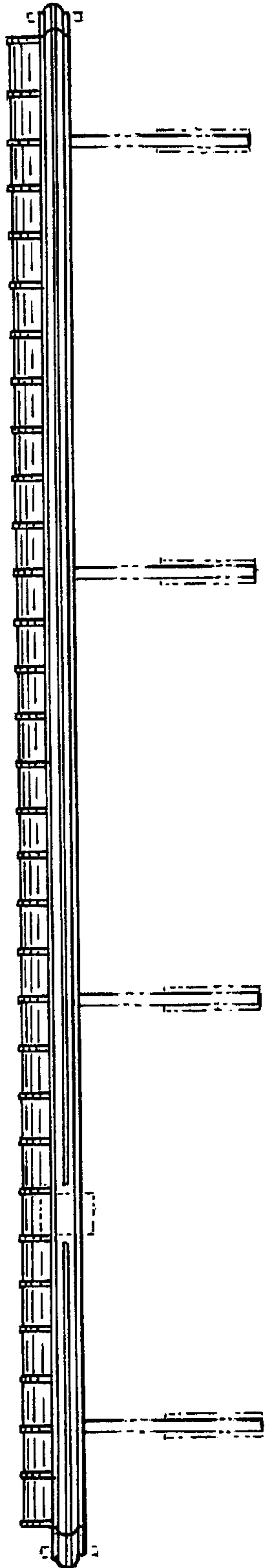

FIG. 4

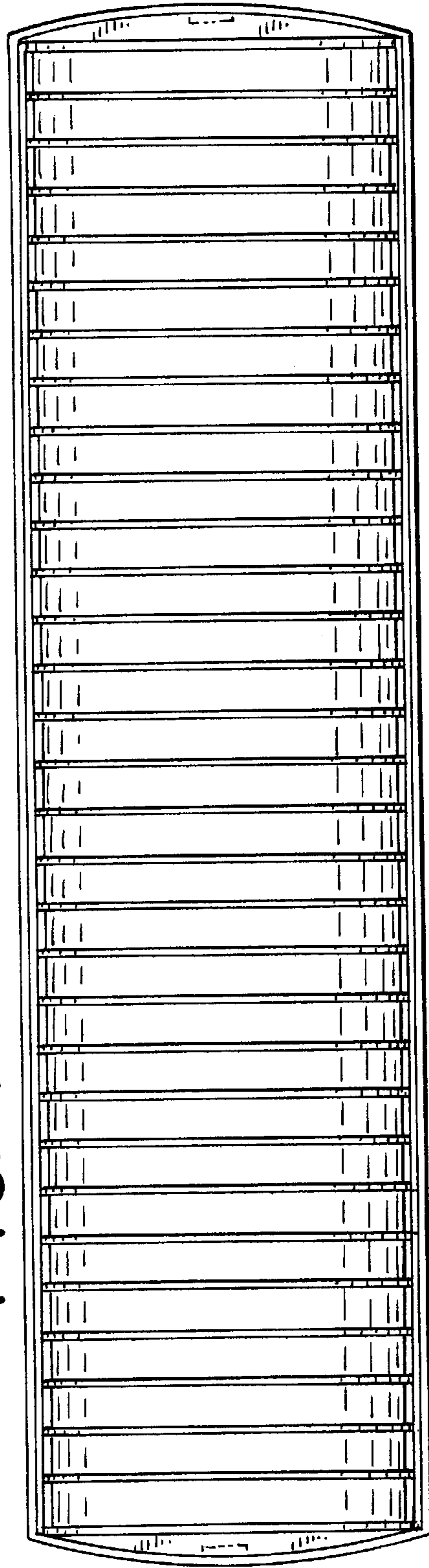

FIG. 5

