



US00D455992S

(12) **United States Design Patent**  
**Chung**

(10) **Patent No.:** **US D455,992 S**

(45) **Date of Patent:** **\*\* Apr. 23, 2002**

(54) **AUTOMOTIVE WHEEL**

(75) **Inventor:** **Suny Chung**, Placentia, CA (US)

(73) **Assignee:** **MKW Alloy, Inc.**, City of Industry, CA (US)

(\*\*) **Term:** **14 Years**

(21) **Appl. No.:** **29/148,400**

(22) **Filed:** **Sep. 20, 2001**

(51) **LOC (7) Cl.** ..... **12-16**

(52) **U.S. Cl.** ..... **D12/209**

(58) **Field of Search** ..... **D12/204-211;**  
**301/37.1, 64.1, 65**

(56) **References Cited**

**U.S. PATENT DOCUMENTS**

D368,464 S	*	4/1996	Morley et al.	.....	D12/209
D420,967 S	*	2/2000	Sacco et al.	.....	D12/209
D432,484 S	*	10/2000	Chung	.....	D12/211
D432,972 S	*	10/2000	Chung	.....	D12/209

D436,573 S	*	1/2001	Neeper	.....	D12/211
D438,504 S	*	3/2001	Muzzarelli	.....	D12/211
D446,493 S	*	8/2001	Sulahian et al.	.....	D12/211
D451,066 S	*	11/2001	Pfeiffer et al.	.....	D12/211
D451,467 S	*	12/2001	Chung	.....	D12/211

\* cited by examiner

*Primary Examiner*—Stacia Cadmus

(74) *Attorney, Agent, or Firm*—G. Donald Weber, Jr.

(57) **CLAIM**

The ornamental design for an automotive wheel, as shown and described.

**DESCRIPTION**

FIG. 1 is an oblique view of the automotive wheel of the instant invention; and,

FIG. 2 is a side elevation view of the automotive wheel of the instant invention.

The broken line showing of environment is for illustrative purposes and forms no part of the claimed design.

**1 Claim, 1 Drawing Sheet**

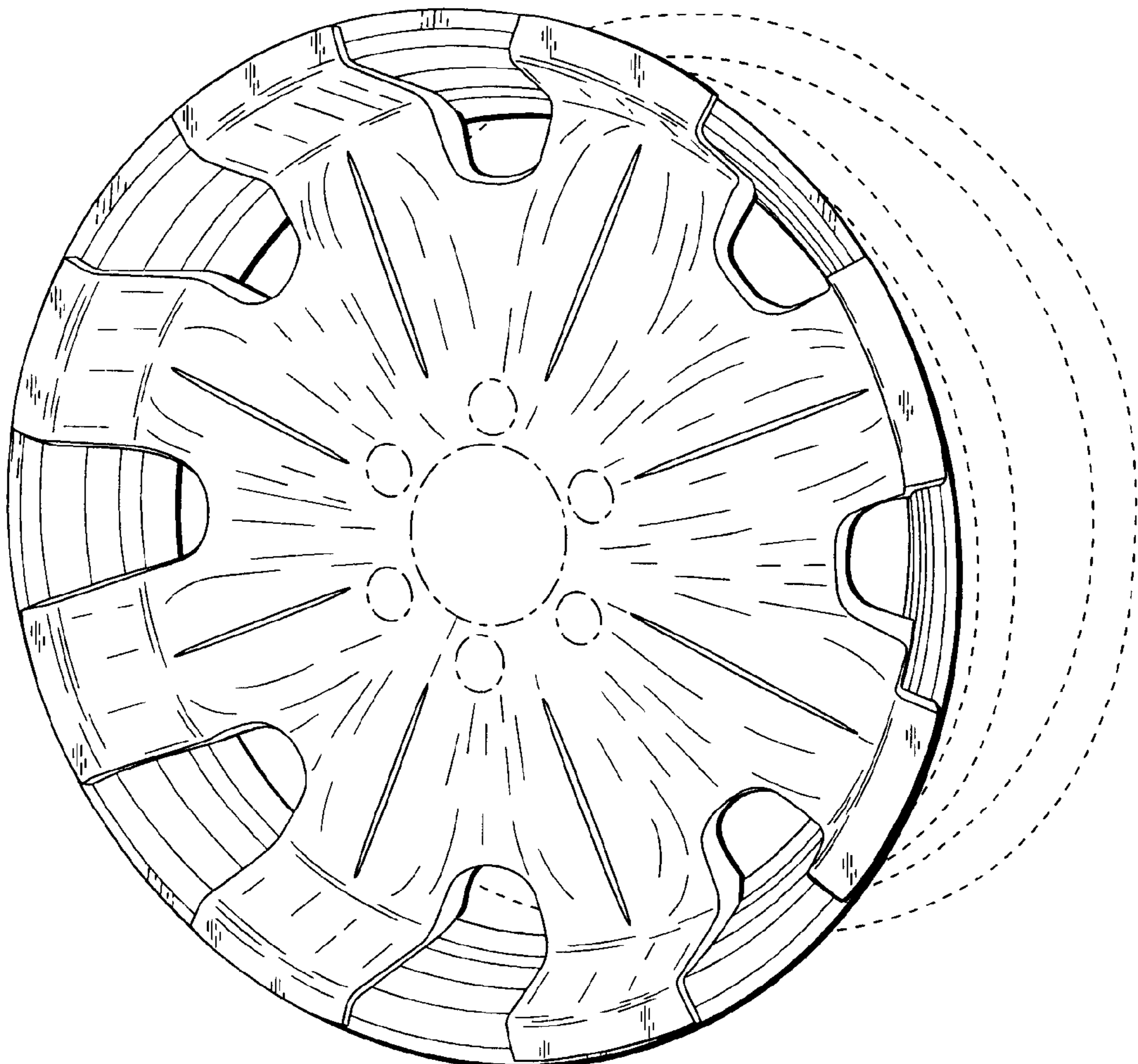

*Fig. 1*

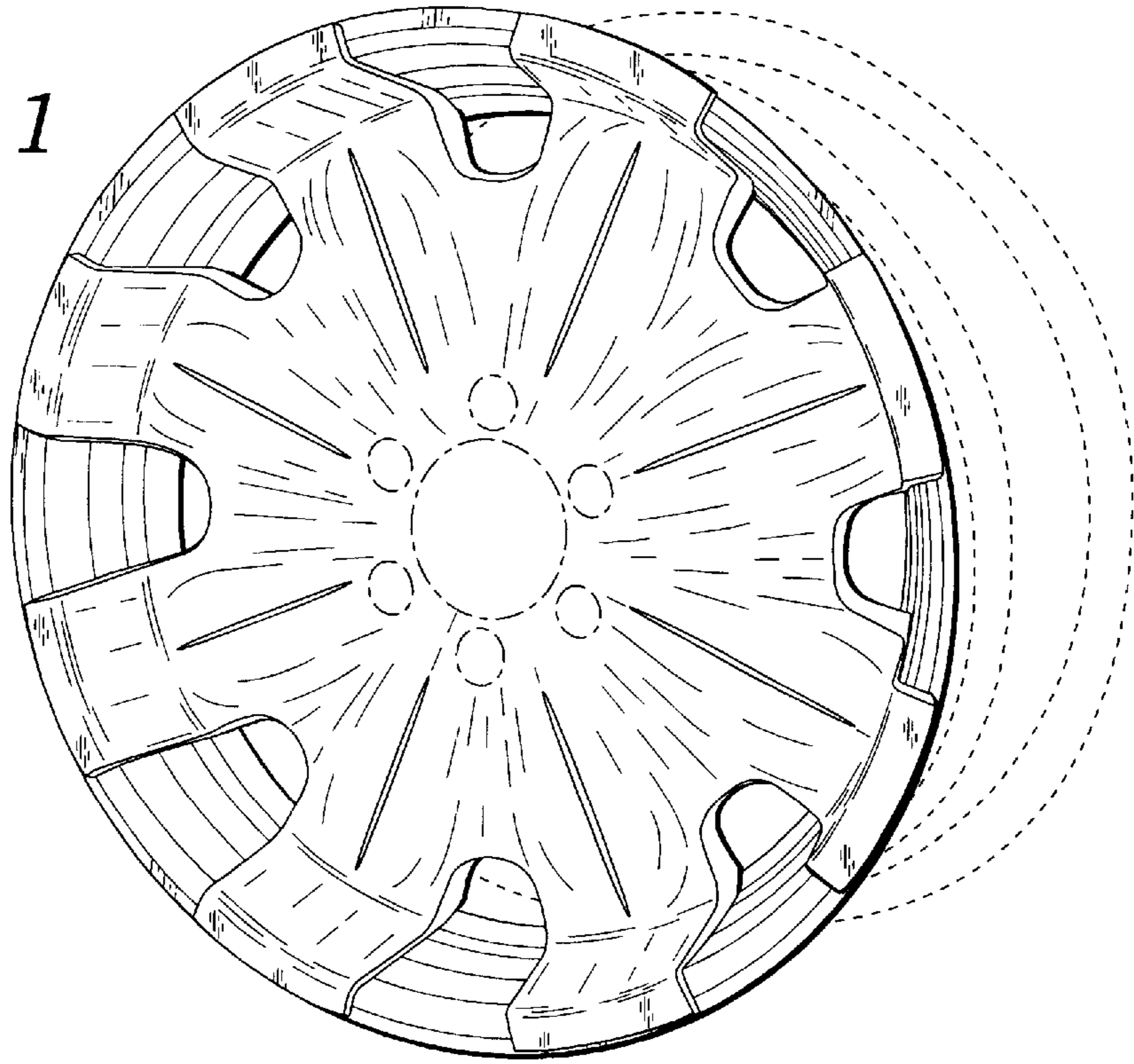

*Fig. 2*

