



US00D455919S

(12) **United States Design Patent**  
**Stewart**

(10) **Patent No.:** **US D455,919 S**

(45) **Date of Patent:** **\*\* Apr. 23, 2002**

(54) **SEAT FRAME**

Landscape Forms Inc. 1995, p. 11, bench at top right.

(75) Inventor: **Kipp Stewart**, Carmel, CA (US)

\* cited by examiner

(73) Assignee: **Landscape Forms, Inc.**, Kalamazoo, MI (US)

*Primary Examiner*—Janice E. Seeger

(\*\*) Term: **14 Years**

(74) *Attorney, Agent, or Firm*—Heslin Rothenberg Farley & Mesiti P.C.

(21) Appl. No.: **29/148,301**

(57) **CLAIM**

(22) Filed: **Sep. 18, 2001**

The ornamental design for a seat frame, as shown and described.

**Related U.S. Application Data**

**DESCRIPTION**

(62) Division of application No. 29/130,231, filed on Sep. 29, 2000, now Pat. No. Des. 450,952.

(51) **LOC (7) Cl.** ..... **06-06**

(52) **U.S. Cl.** ..... **D6/499; D6/500**

(58) **Field of Search** ..... D6/349, 350, 351–353, D6/370, 355, 381, 337, 364, 495–499, 500, 387, 382; 297/461, 462, 195.11, 423.1, 423.11, 423.39, 423.41, 423.42, 423.43

FIG. 1 is an isometric view of a first embodiment of the seat frame of my design;

FIG. 2 is a top plan view thereof;

FIG. 3 is a front elevational view thereof;

FIG. 4 is a left side elevational view thereof, the right side elevational view being a mirror image thereof;

FIG. 5 is a back elevational view thereof;

FIG. 6 is a bottom plan view thereof;

FIG. 7 is an isometric view of a second embodiment which view differs from FIG. 1 only by the broken line showing of side arms; and,

FIG. 8 is an isometric view of the first embodiment which view differs from FIG. 1 only by the broken line showing of a seat structure.

The broken line showing in the drawing figures is for illustrative purposes only and forms no part of the claimed design.

(56) **References Cited**

**U.S. PATENT DOCUMENTS**

2,353,220	A	7/1944	Charlop	.....	5/127
D299,595	S	* 1/1989	Shields	.....	D6/335
4,975,994	A	12/1990	Barmettler	.....	5/120
D386,322	S	11/1997	Maury	.....	D6/370
D450,952	S	* 11/2001	Stewart	.....	D6/499
D451,296	S	* 12/2001	Stewart	.....	D6/370

**OTHER PUBLICATIONS**

Sling Console Table, Bradford Stewart & Company, Palo Alto, CA, 1995, 2 pp.

Poolside Collection, Bradford Stewart & Company, Oakland, CA, 1996, 2pp.

**1 Claim, 8 Drawing Sheets**

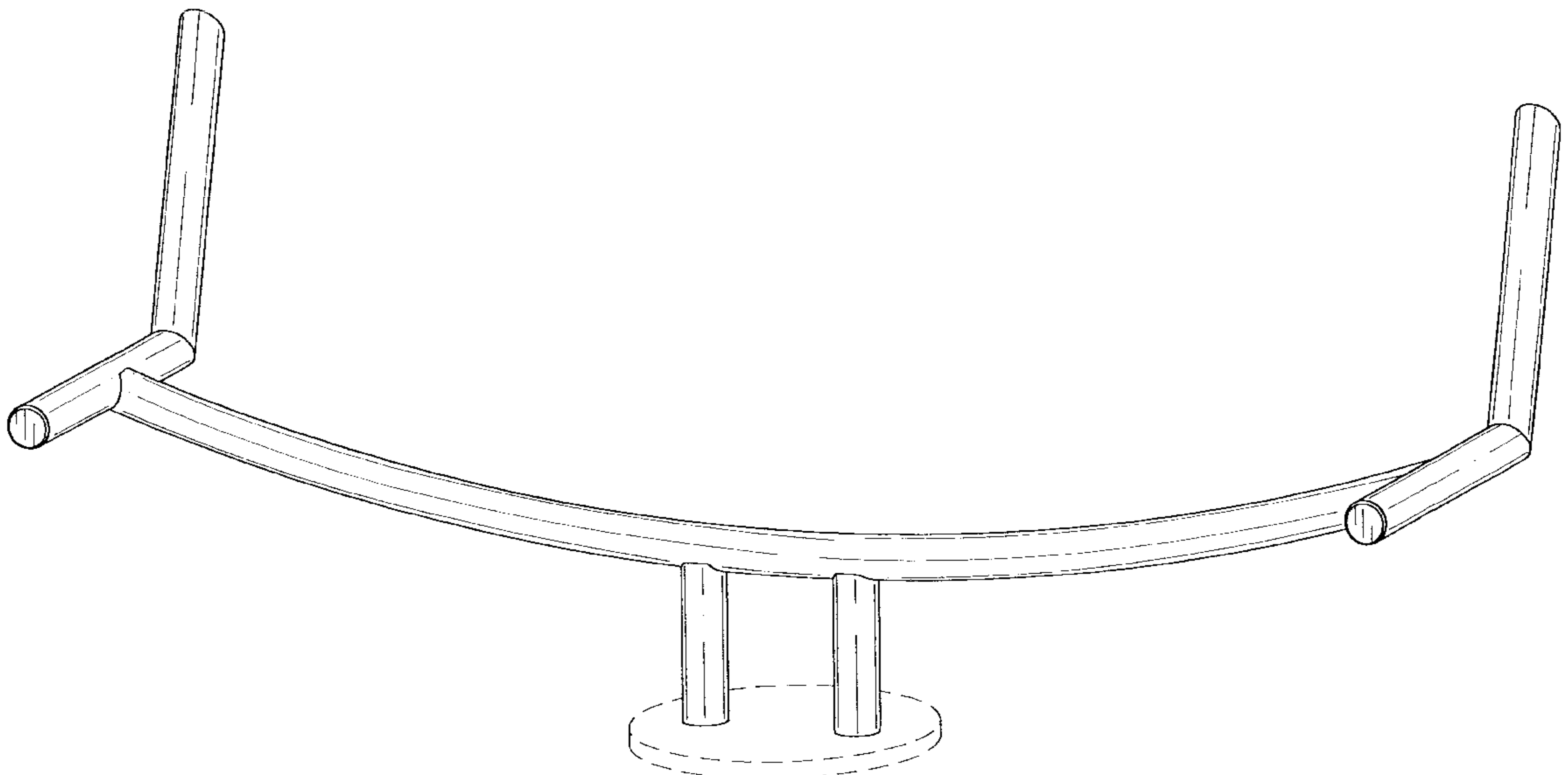

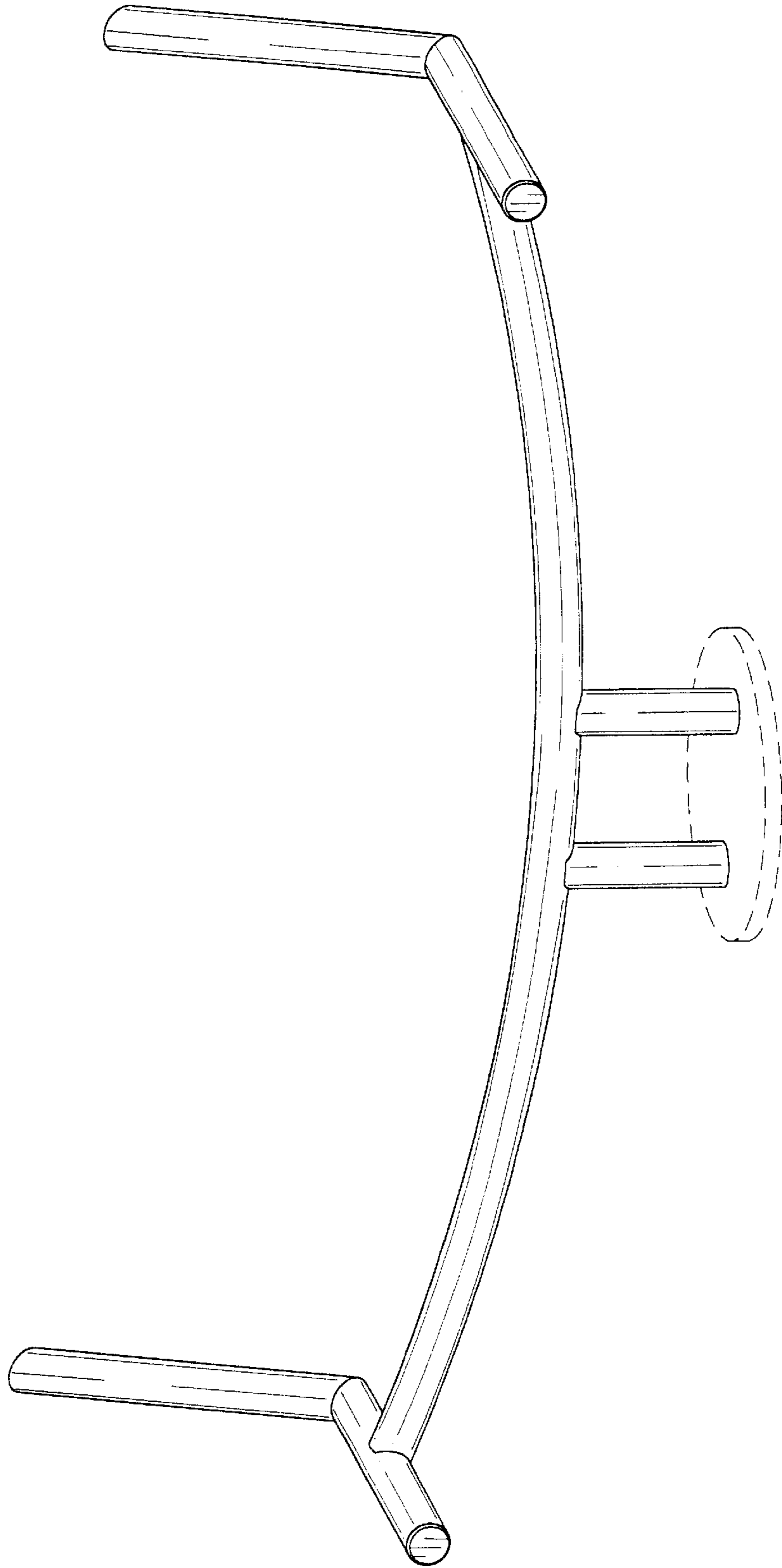

FIG. 1

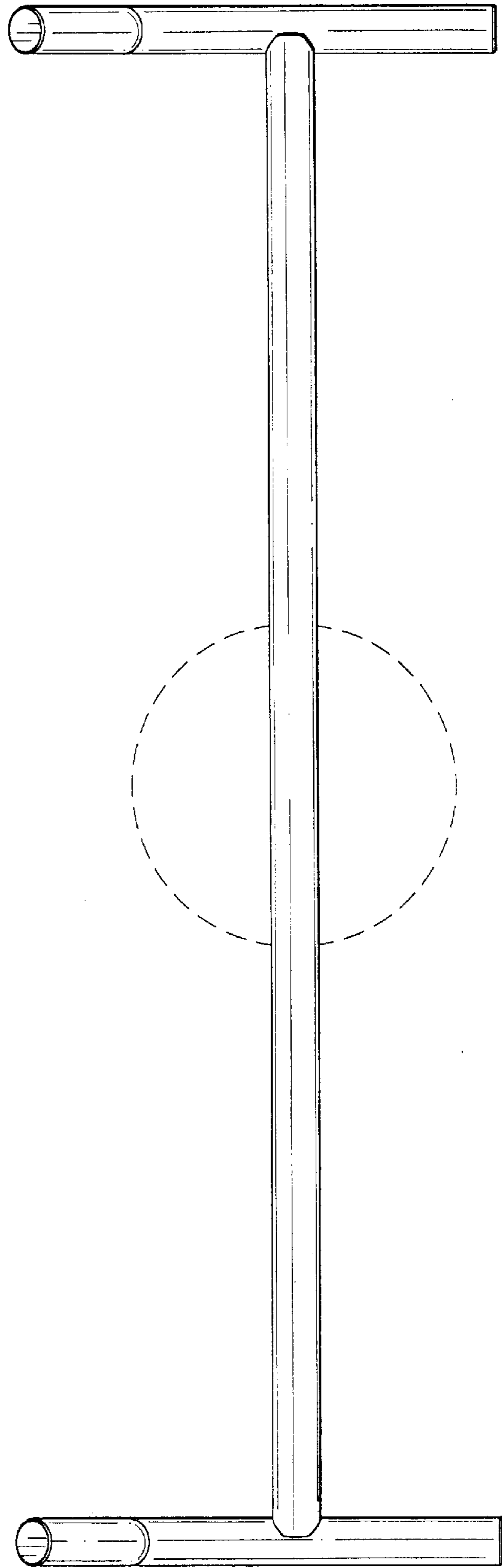
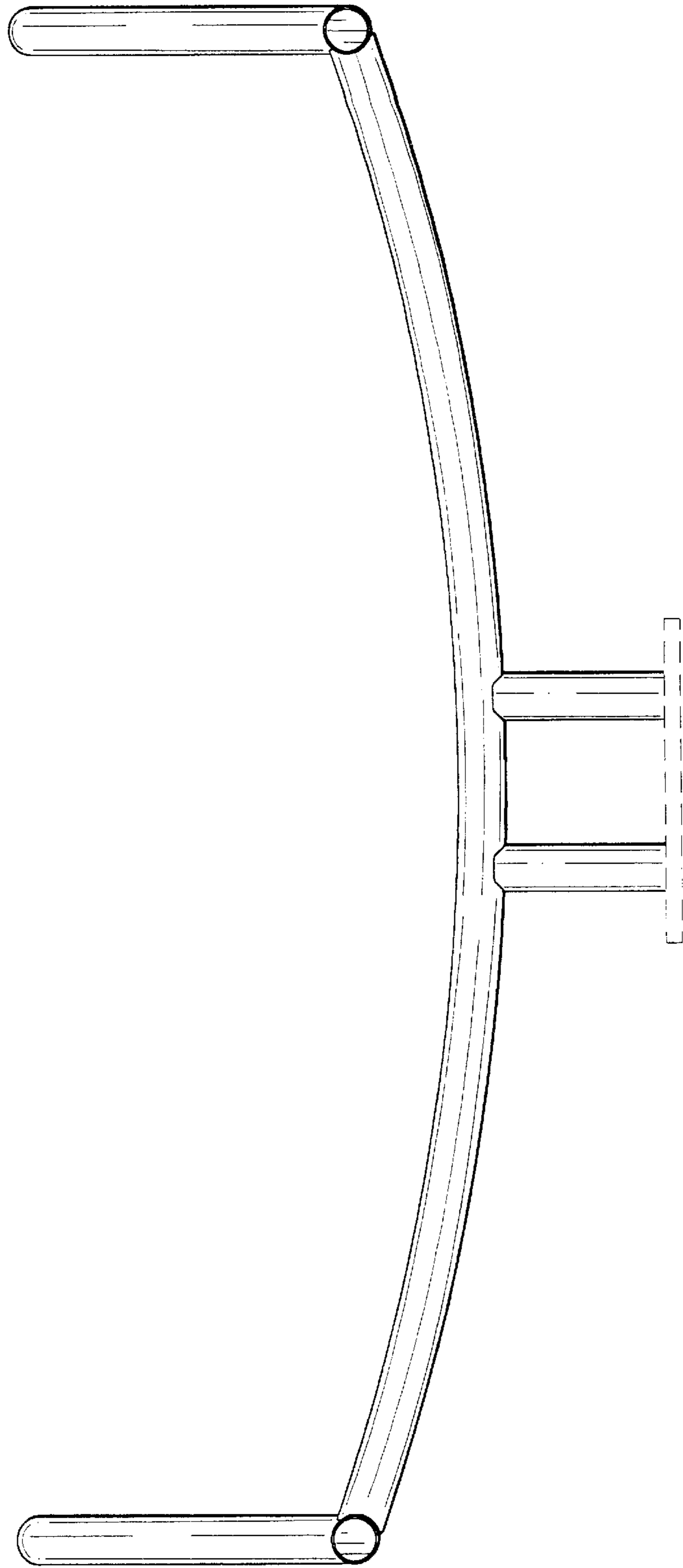

FIG. 2

FIG. 3



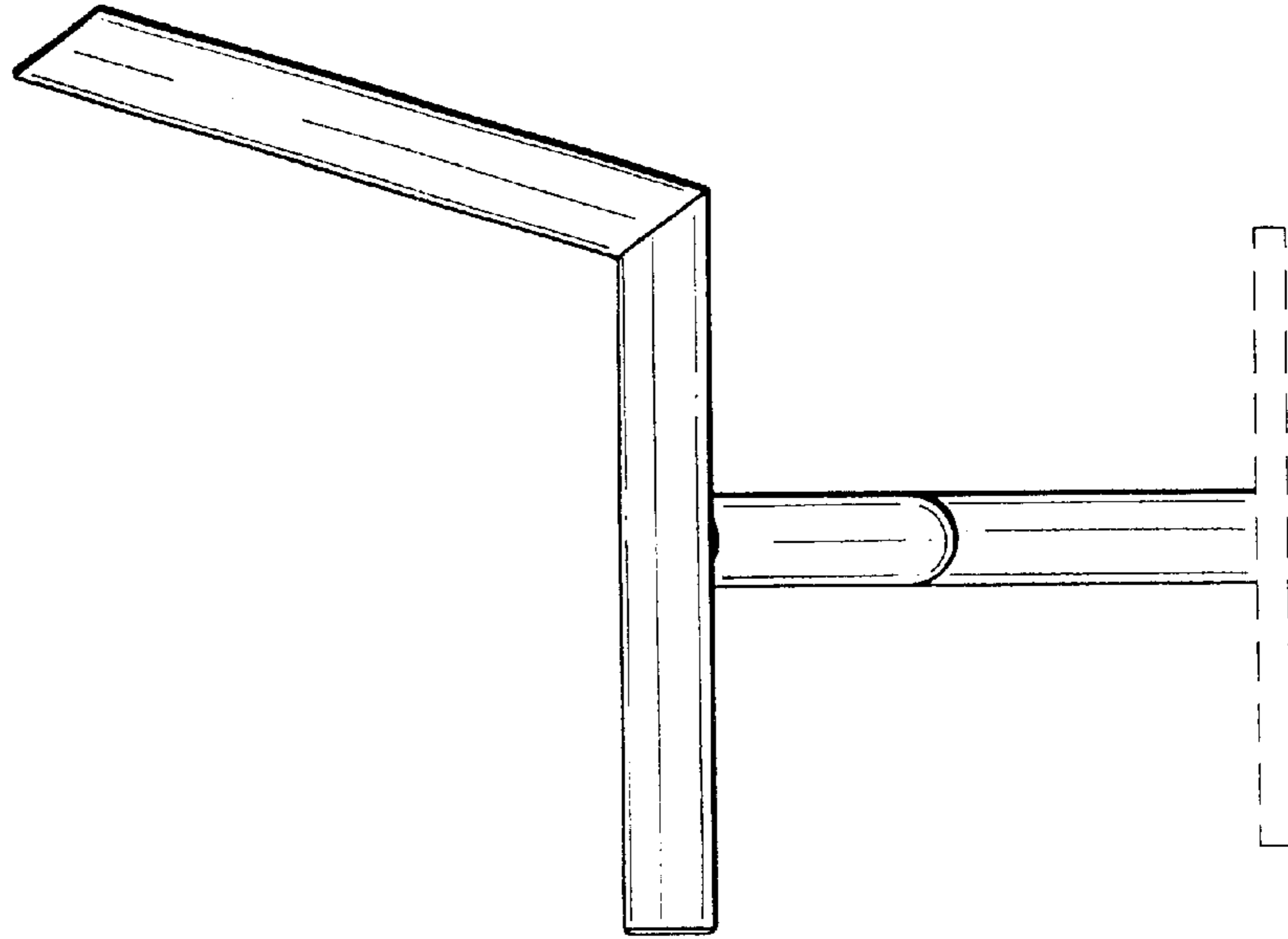

FIG. 4

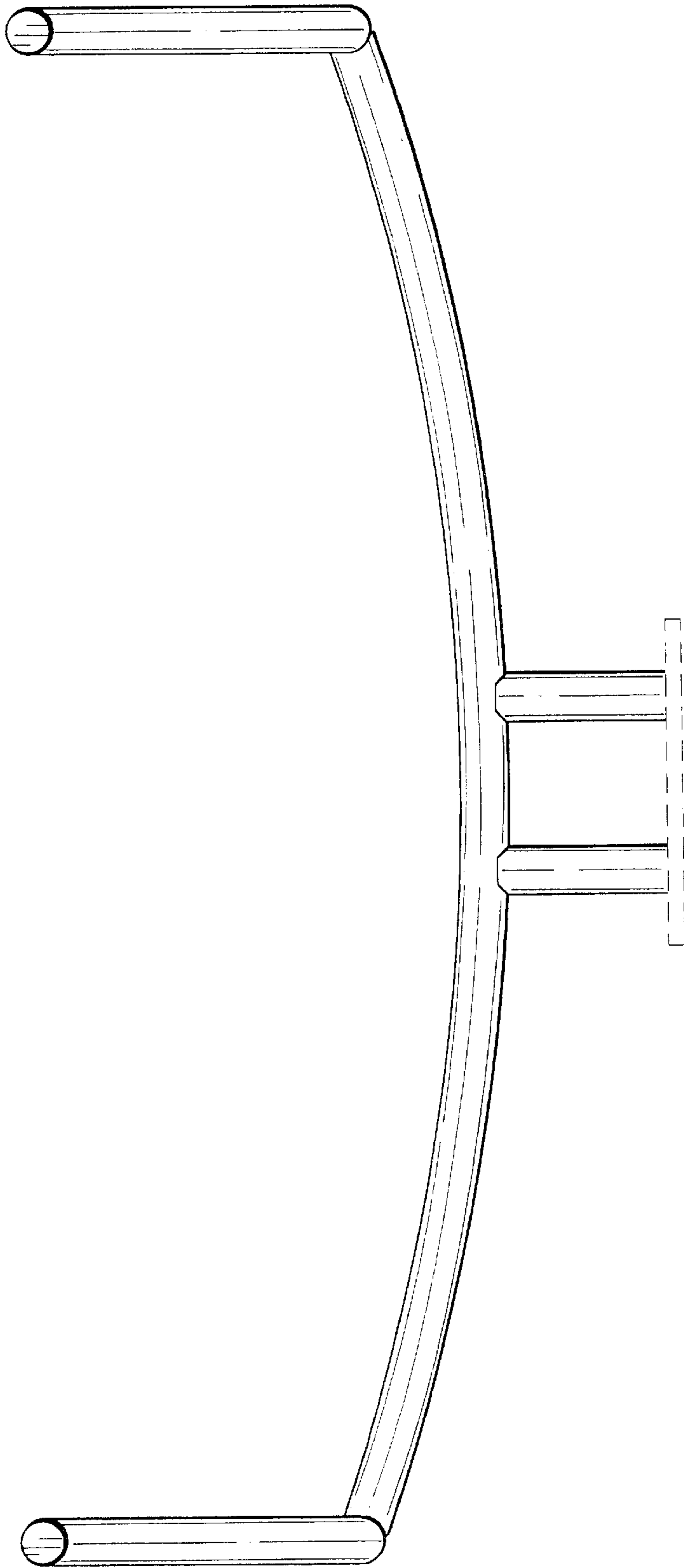

FIG. 5

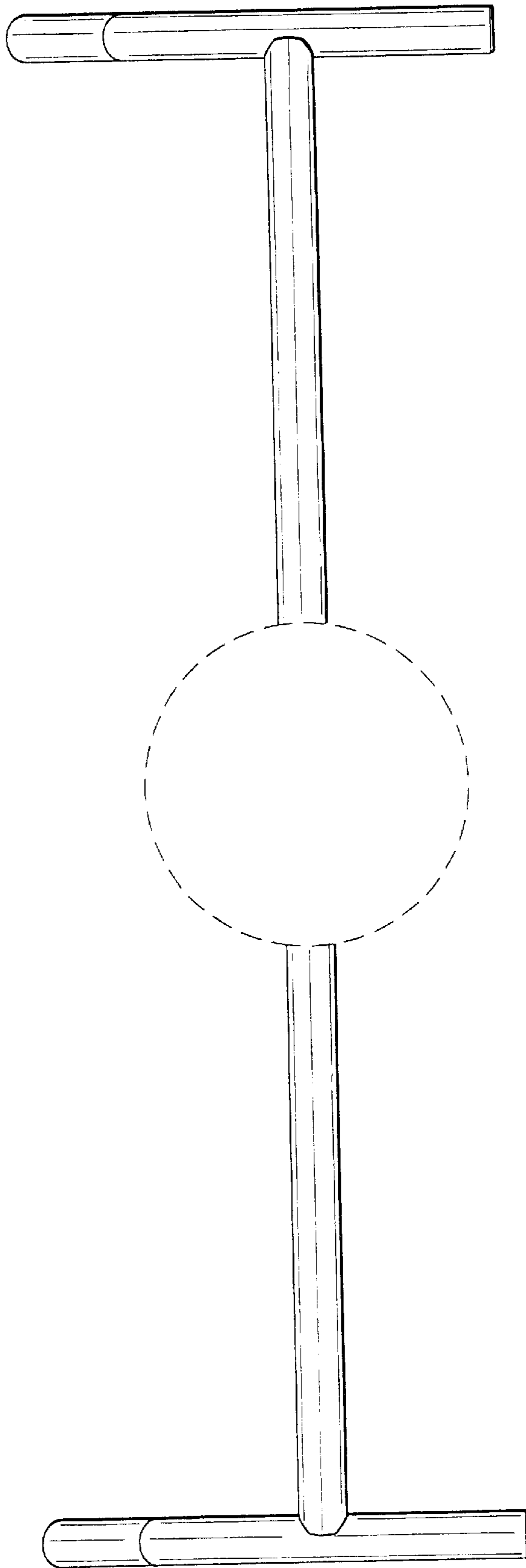

FIG. 6

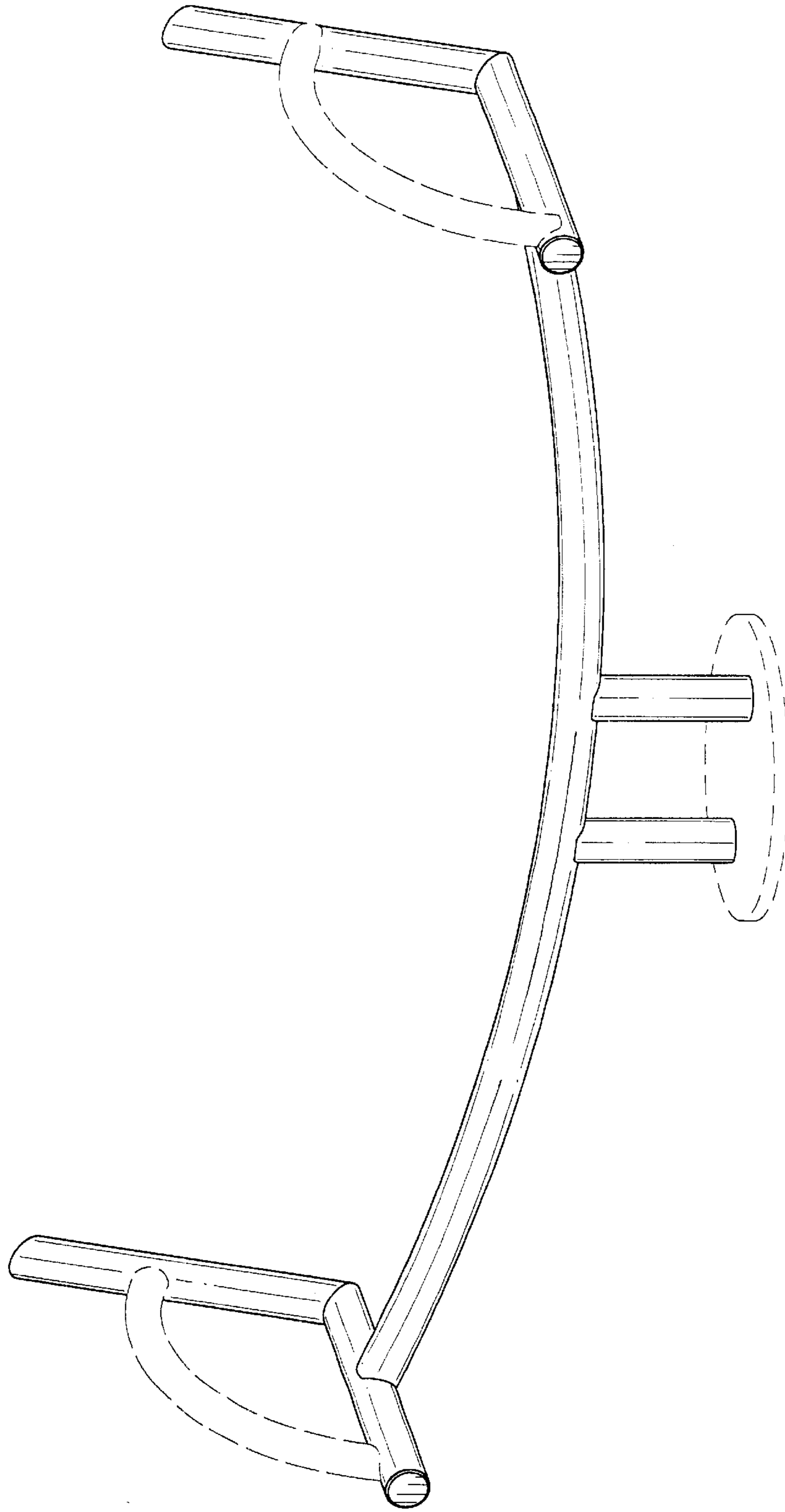

FIG. 7



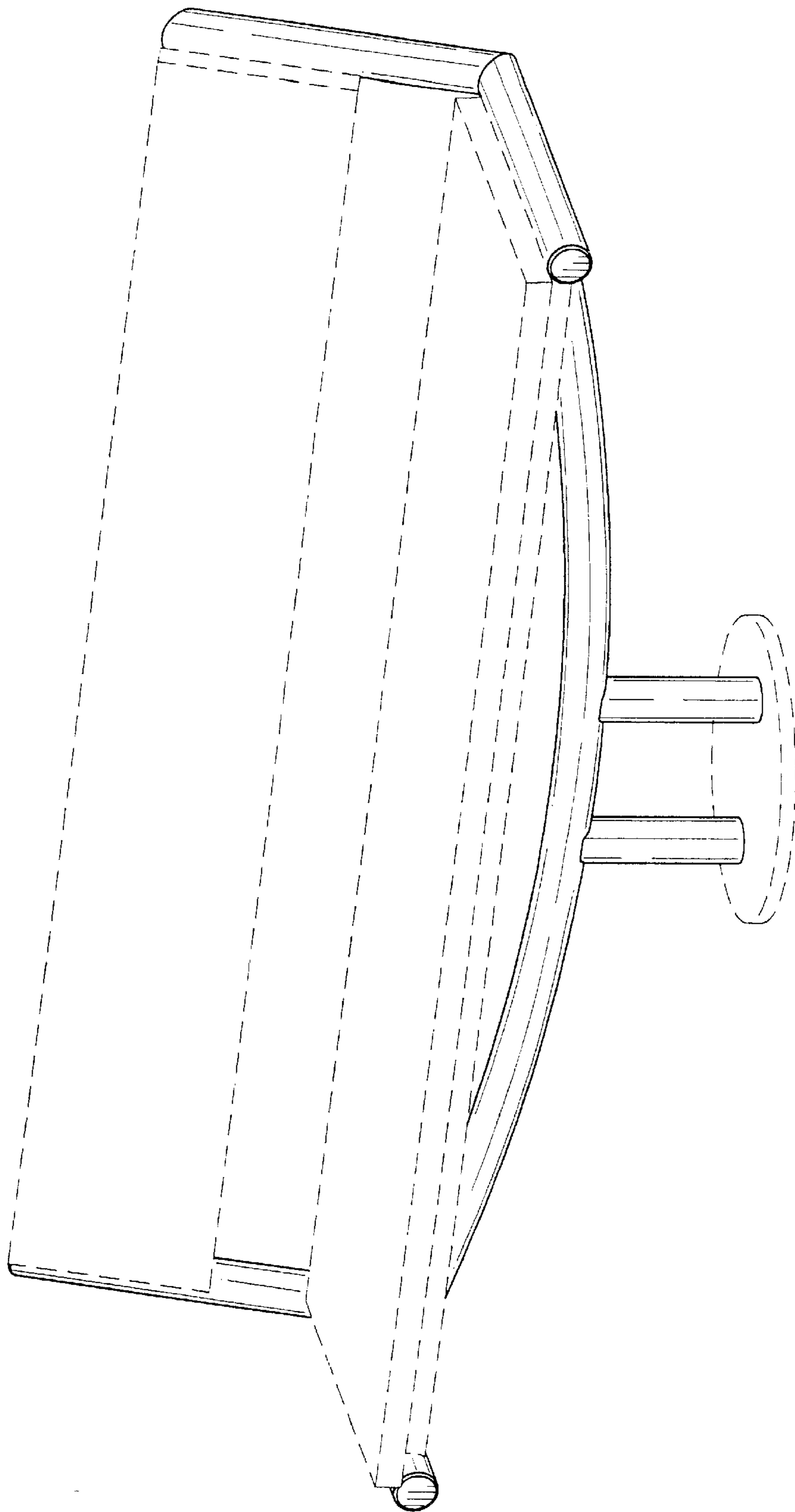

FIG. 8