



US00D455678S

(12) **United States Design Patent**
Schroeder et al.

(10) **Patent No.:** **US D455,678 S**

(45) **Date of Patent:** **** Apr. 16, 2002**

(54) **MOTORCYCLE**

(75) Inventors: **Anthony Schroeder**, Huntington Beach; **Tetsuya Nakazawa**, Rancho Palos Verdes; **Michael Keating**; **Ramon Meneses**, both of Redondo Beach, all of CA (US)

(73) Assignee: **Honda Giken Kogyo Kabushiki Kaisha**, Tokyo (JP)

(**) Term: **14 Years**

(21) Appl. No.: **29/144,425**

(22) Filed: **Jul. 3, 2001**

(51) **LOC (7) Cl.** **12-11**

(52) **U.S. Cl.** **D12/110**

(58) **Field of Search** **D12/110; 180/219**

(56) **References Cited**

U.S. PATENT DOCUMENTS

D382,835 S	*	8/1997	Abe et al.	D12/110
D387,017 S	*	12/1997	Wakita et al.	D12/110
D422,244 S	*	4/2000	Heinrich et al.	D12/110

* cited by examiner

Primary Examiner—Alan P. Douglas

Assistant Examiner—Linda Brooks

(74) *Attorney, Agent, or Firm*—Banner & Witcoff, Ltd.

(57) **CLAIM**

The ornamental design for a motorcycle, as shown and described.

DESCRIPTION

FIG. 1 is a right front perspective view of a motorcycle showing our new design;

FIG. 2 is a right rear perspective view thereof;

FIG. 3 is an elevational view of the right side thereof;

FIG. 4 is a left front perspective view thereof;

FIG. 5 is a left rear perspective view thereof;

FIG. 6 is a front view thereof;

FIG. 7 is a rear view thereof;

FIG. 8 is a top plan view thereof; and,

FIG. 9 is an elevational view of the left side thereof.

The broken line showings of the tires are for illustrative purposes only and form no part of the claimed design.

1 Claim, 8 Drawing Sheets

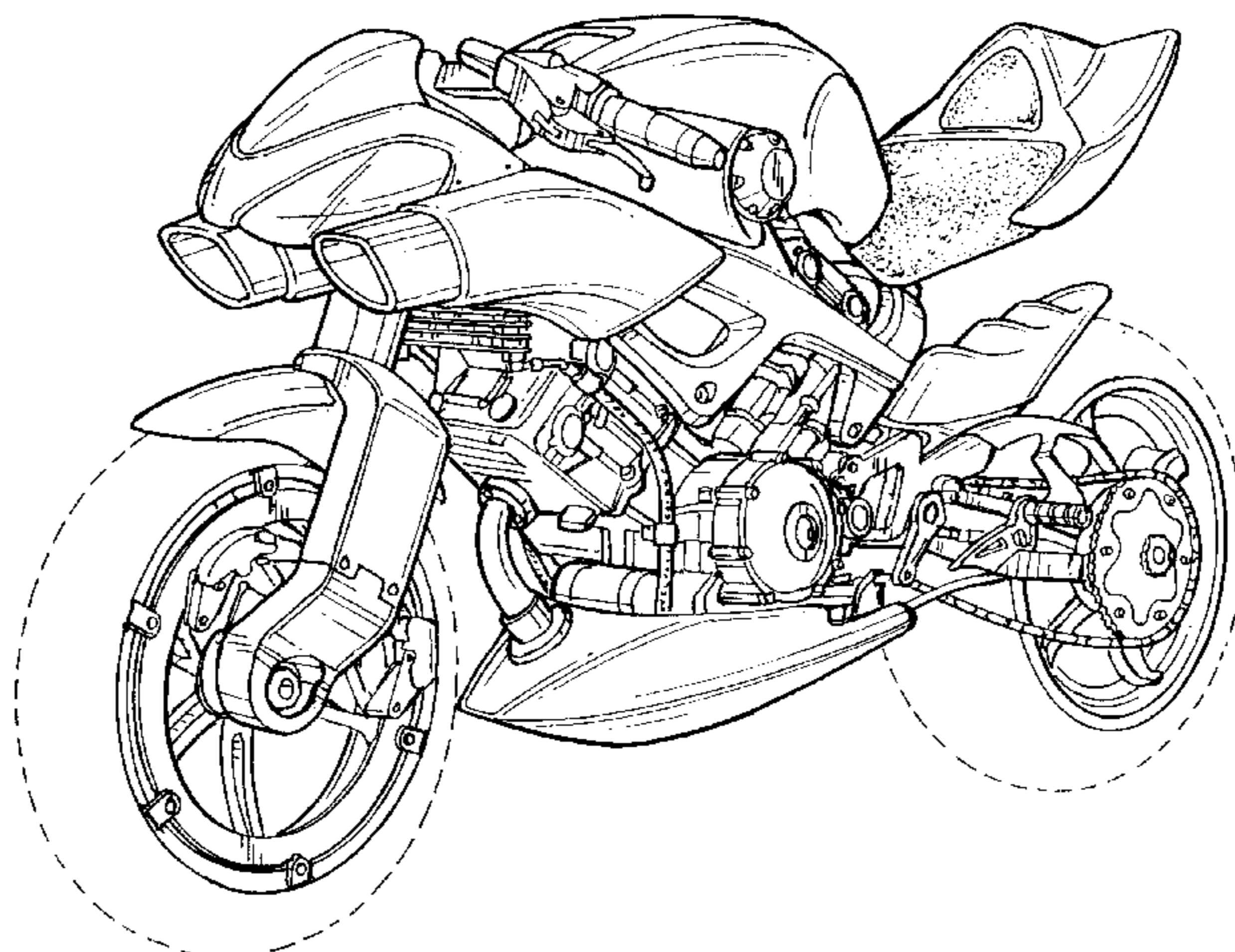
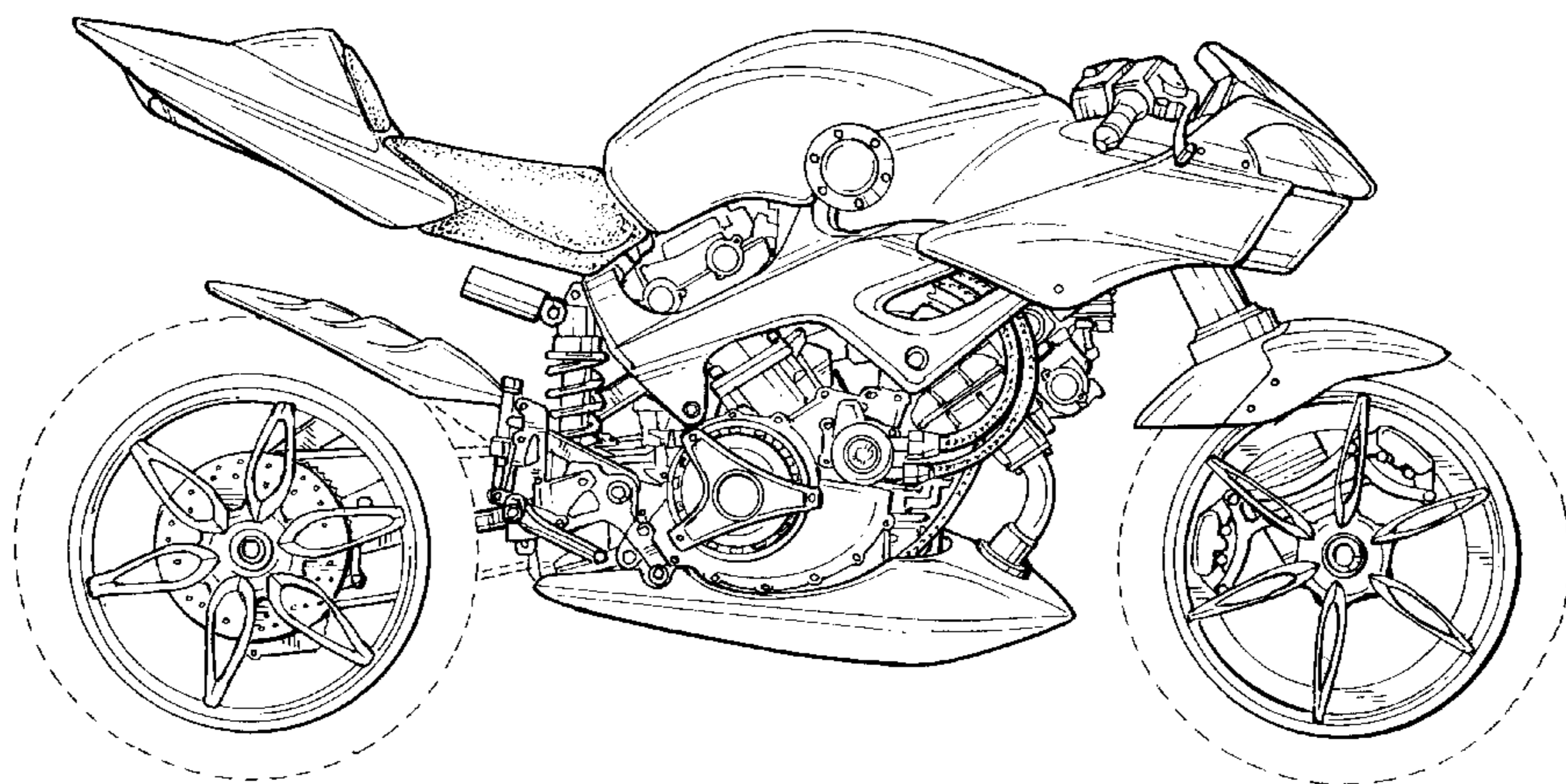

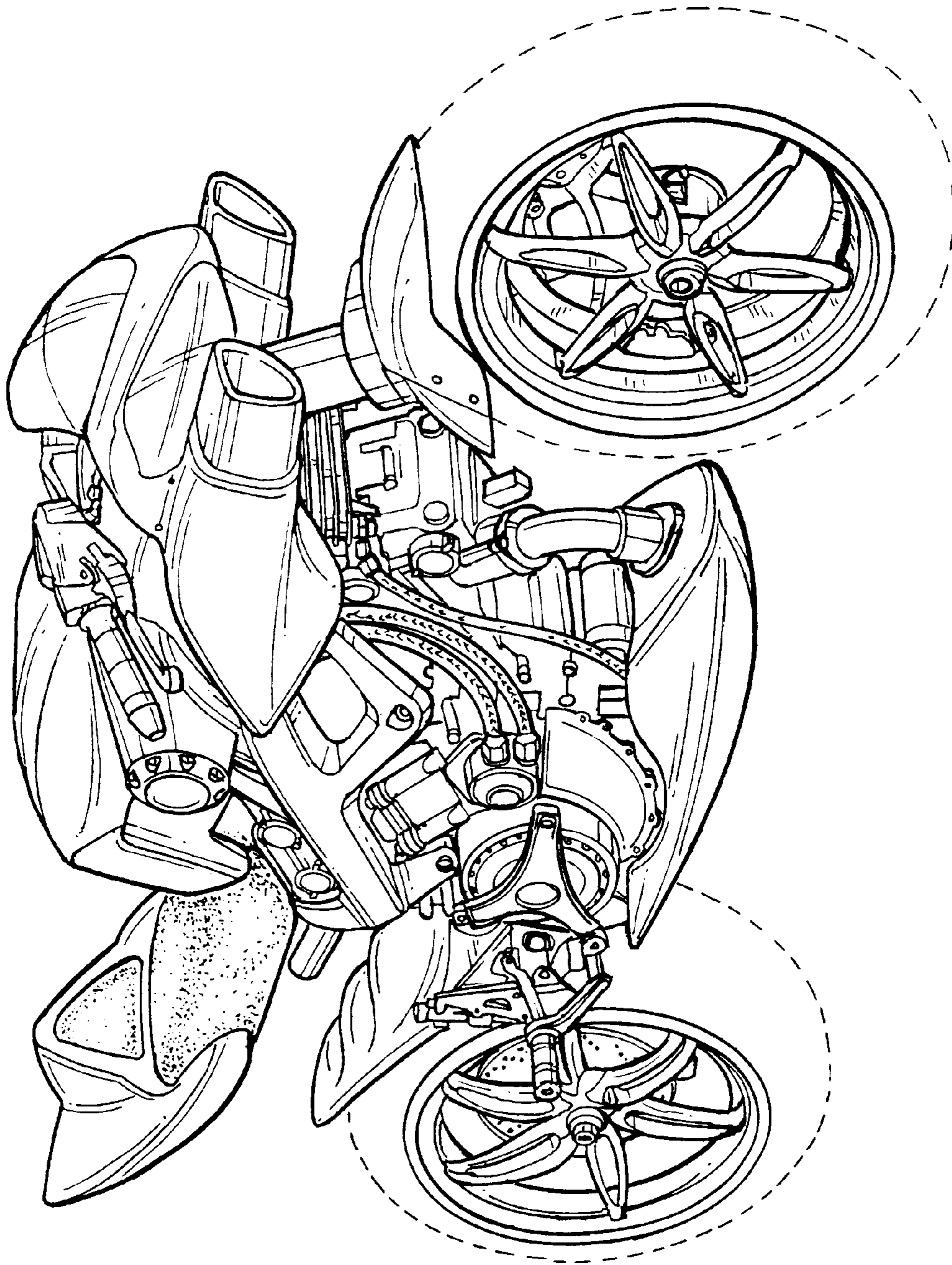

FIG. 1

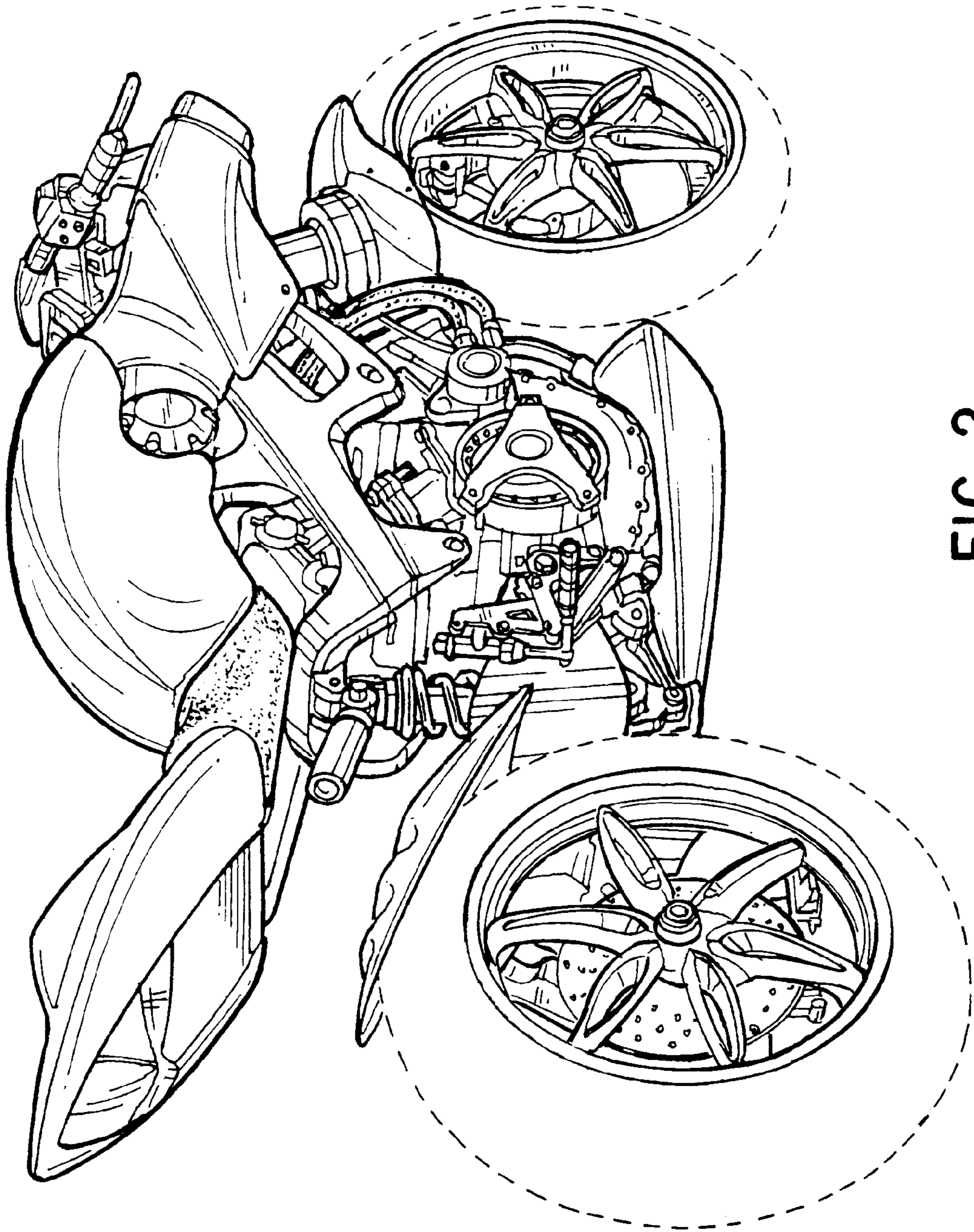

FIG. 2

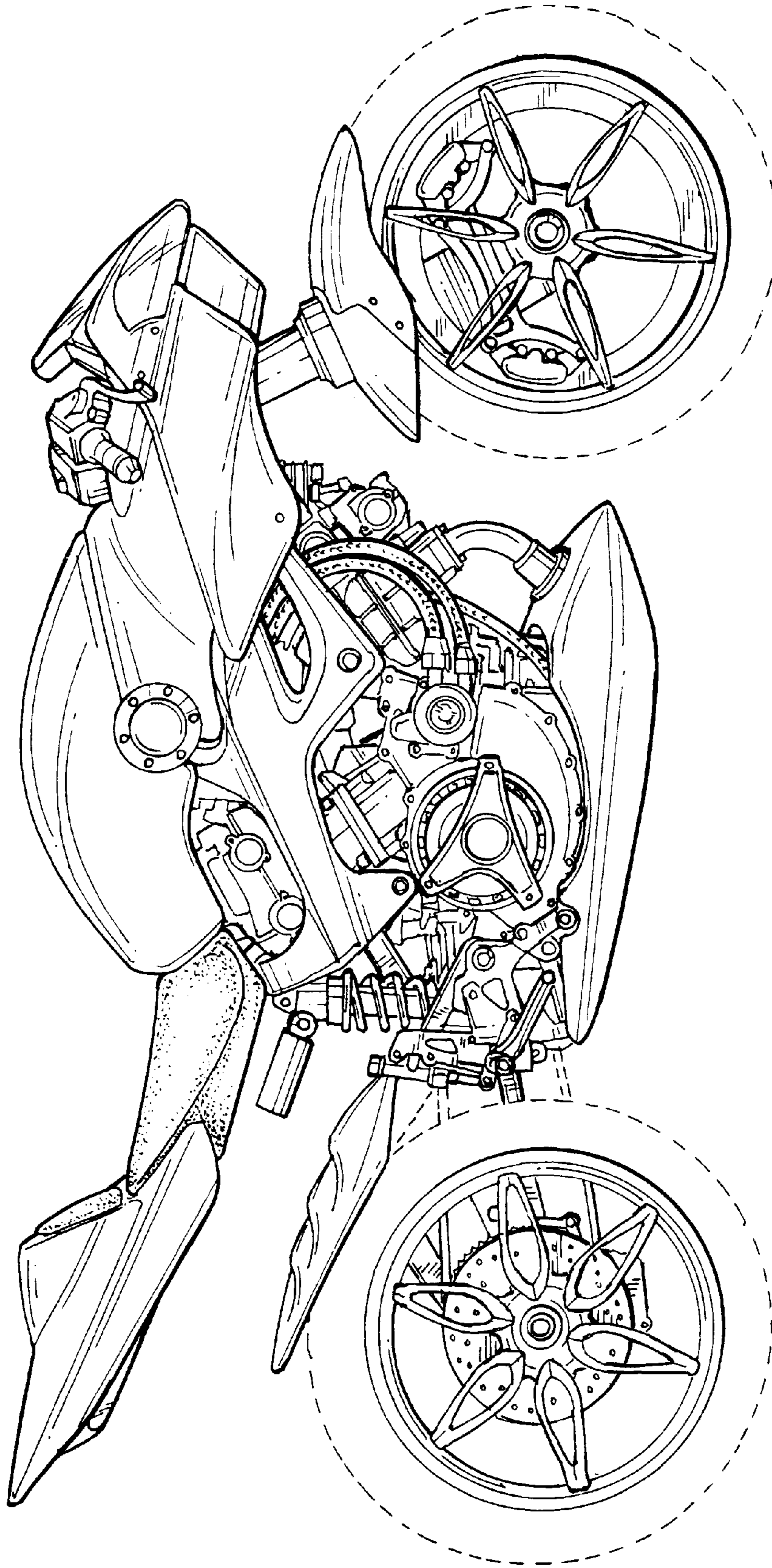

FIG. 3

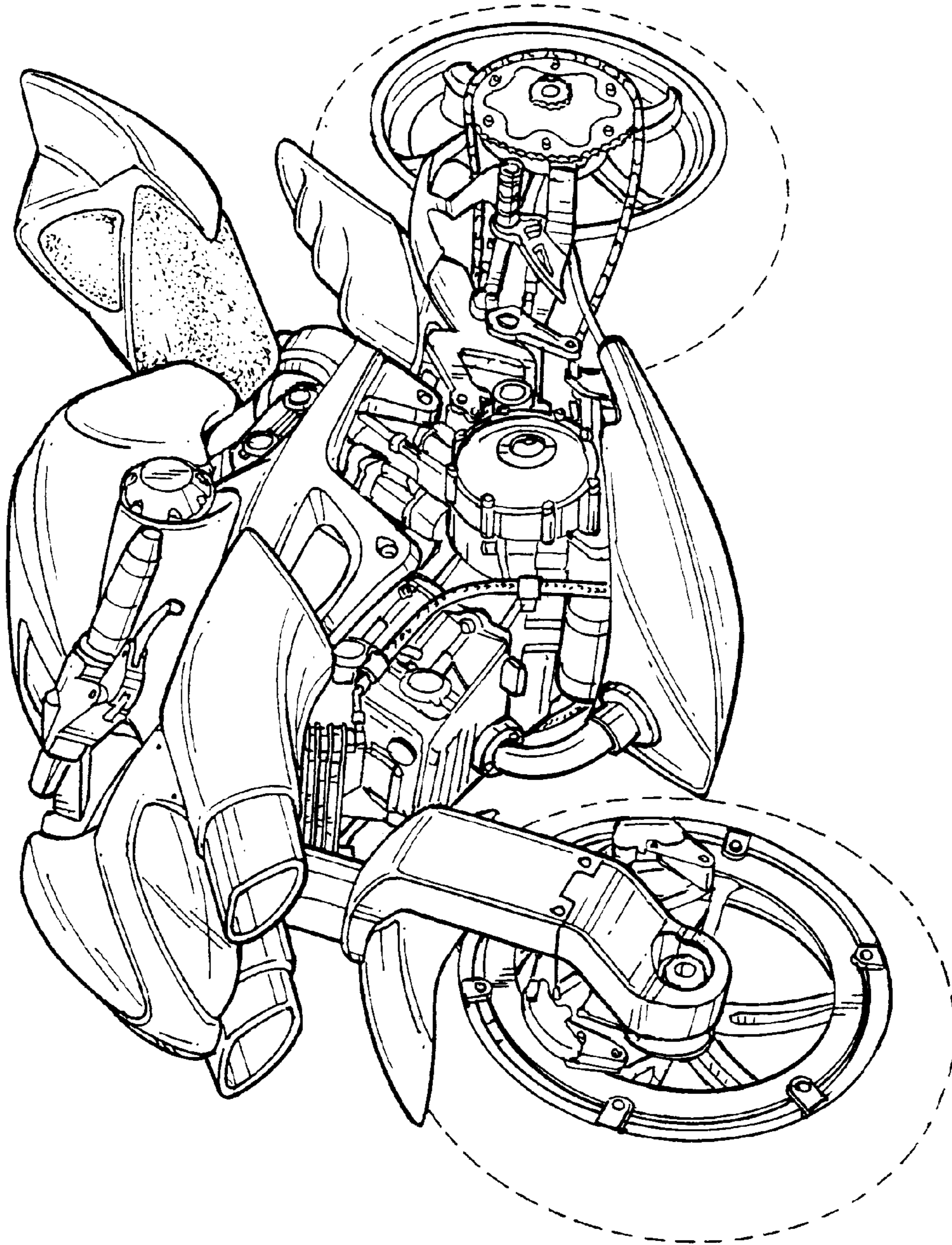

FIG. 4

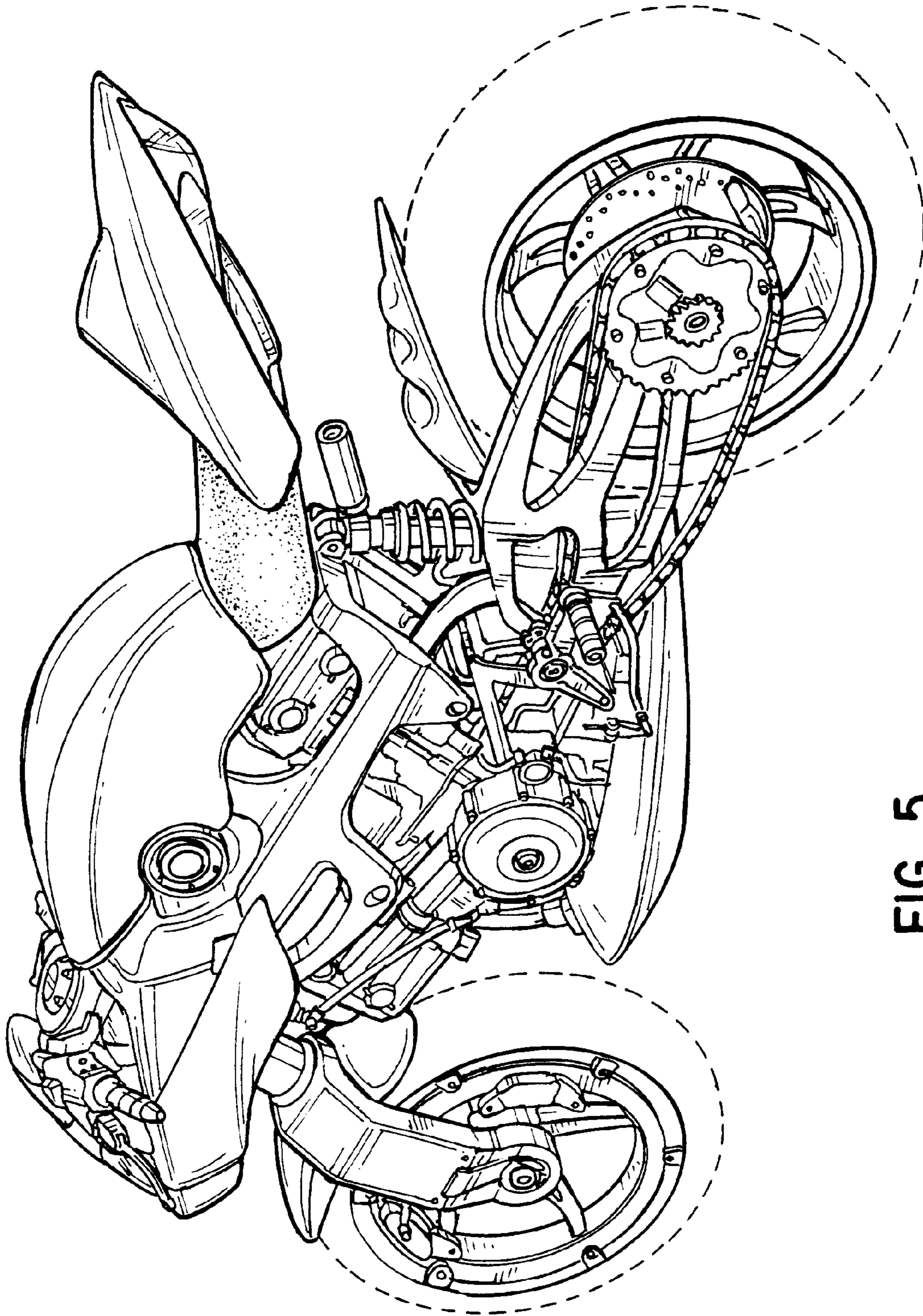

FIG. 5

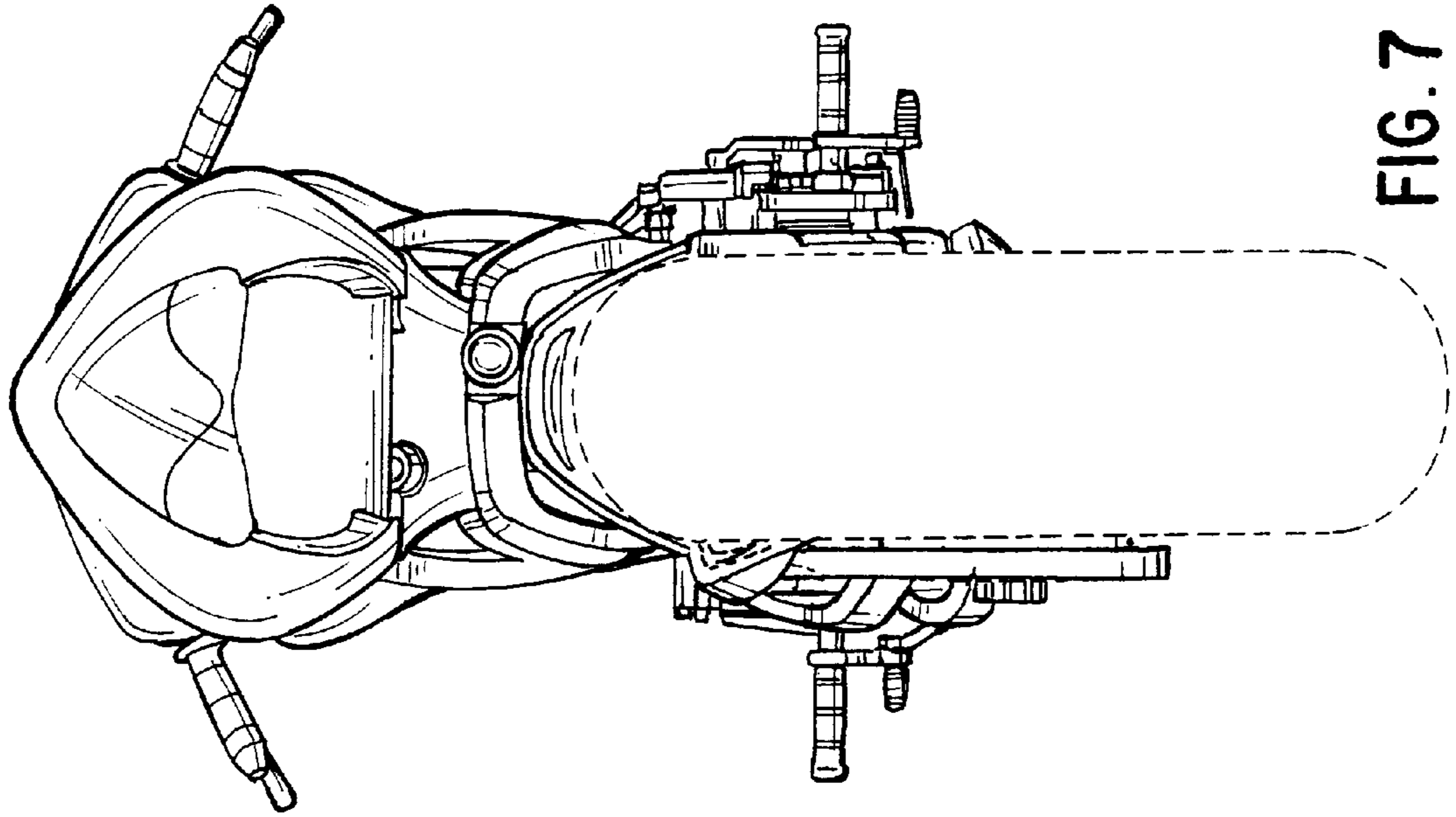

FIG. 7

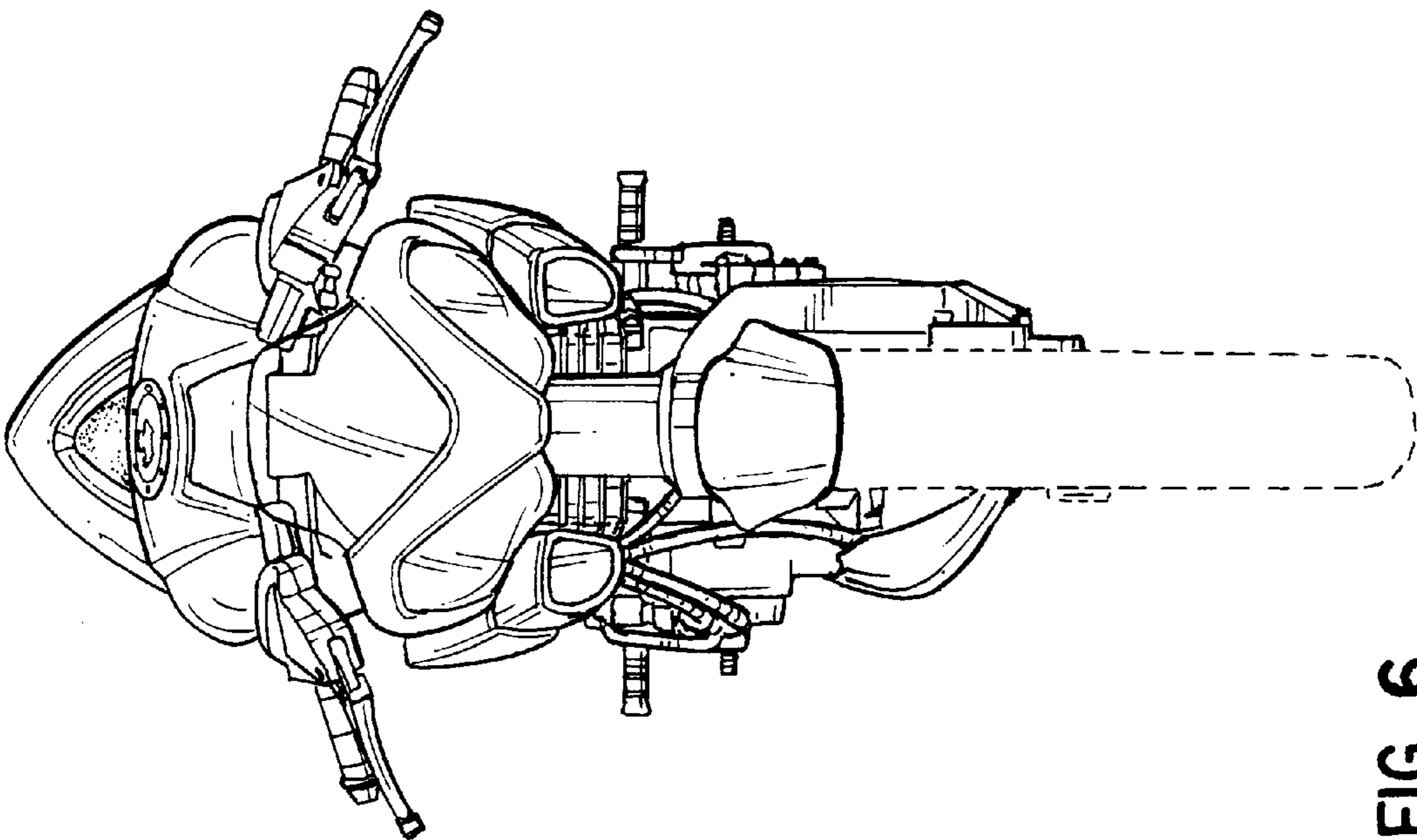

FIG. 6

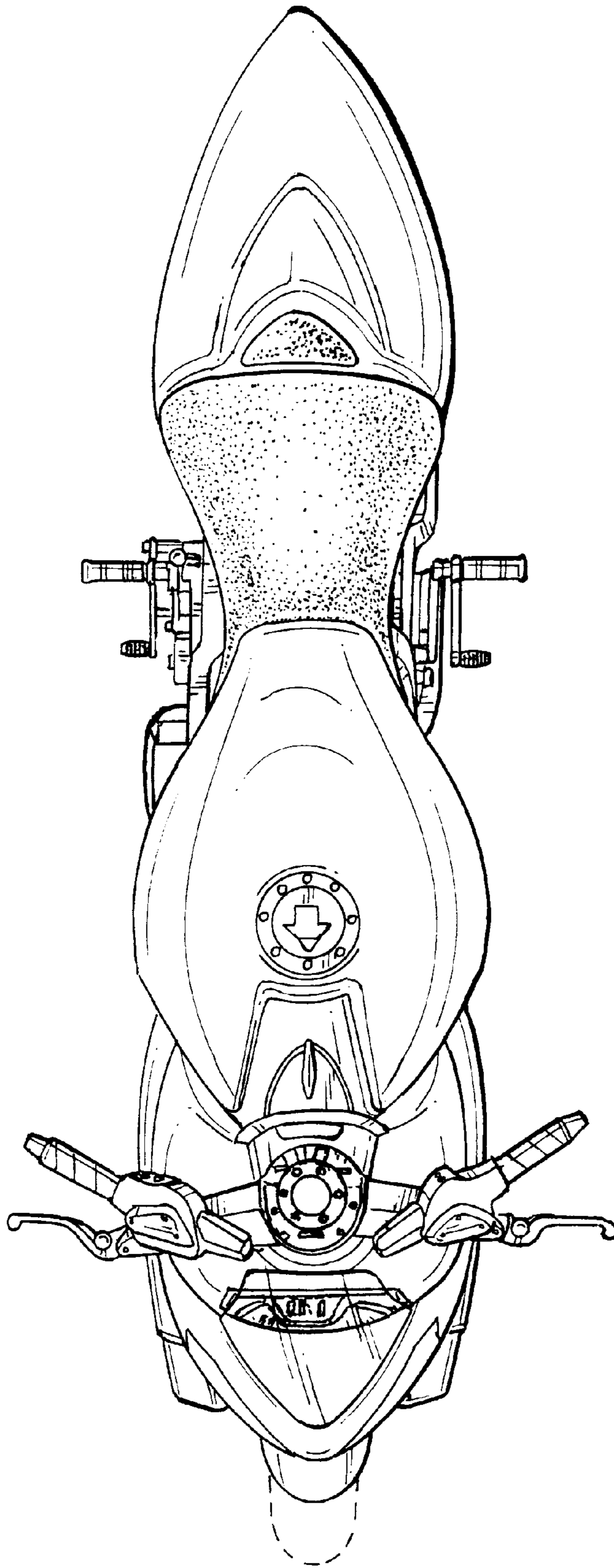

FIG. 8

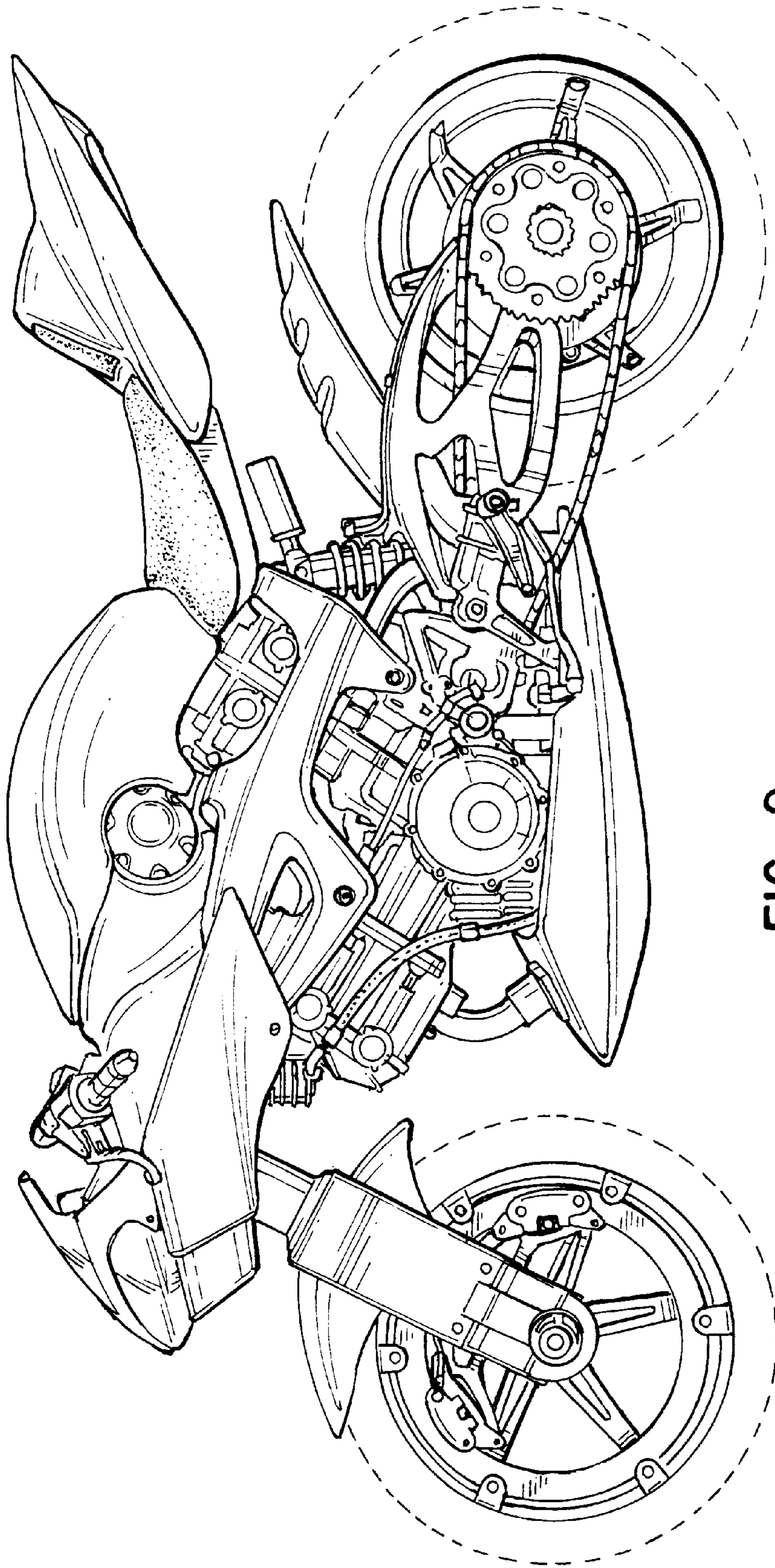

FIG. 9