



US00D455610S

(12) **United States Design Patent**  
**Bridges**

(10) **Patent No.:** **US D455,610 S**

(45) **Date of Patent:** **\*\* Apr. 16, 2002**

(54) **BEVERAGE MUG**

(75) Inventor: **John A. Bridges**, Nashville, TN (US)

(73) Assignee: **Aladdin Industries, L.L.C.**, Nashville, TN (US)

(\*\*) Term: **14 Years**

(21) Appl. No.: **29/146,856**

(22) Filed: **Aug. 20, 2001**

(51) **LOC (7) Cl.** ..... **07-01**

(52) **U.S. Cl.** ..... **D7/536; D7/533**

(58) **Field of Search** ..... **D7/536, 533, 523, D7/509; 220/736, 23.8, 738, 719, 695, 711, 696, 256, 710.5, 630, 737, 501; 215/396, 10; 210/474; 206/520; 219/432; 62/457.3**

(56) **References Cited**

**U.S. PATENT DOCUMENTS**

2,215,691	A	*	9/1940	East	.....	220/501
D254,463	S	*	3/1980	Wilson	.....	D7/536
D279,948	S	*	8/1985	Weernink	.....	D7/536
5,029,720	A	*	7/1991	Bridges	.....	220/737
5,154,306	A		10/1992	Wyatt		
D334,322	S	*	3/1993	Huang	.....	D7/536
D334,869	S	*	4/1993	Mills	.....	D7/605
D338,591	S		8/1993	Wyatt et al.		
5,249,703	A	*	10/1993	Karp	.....	220/719
5,294,014	A		3/1994	Wyatt et al.		
5,312,013	A		5/1994	Bridges		
D351,314	S	*	10/1994	Sokolski et al.	.....	D7/536
5,398,842	A	*	3/1995	Sokolski et al.	.....	220/630
5,414,312	A		5/1995	Mueller		
D362,156	S		9/1995	Goto et al.		
D362,369	S		9/1995	Bridges		
D363,414	S		10/1995	Goto et al.		
D363,641	S		10/1995	Goto et al.		
D363,642	S		10/1995	Goto et al.		
D363,665	S		10/1995	Goto et al.		
D363,666	S		10/1995	Goto et al.		
D366,186	S		1/1996	Kato		
D371,049	S	*	6/1996	Cuthbertson et al.	.....	D7/536

D371,936	S		7/1996	Goto et al.		
D398,815	S		9/1998	Hatsumoto et al.		
D411,713	S		6/1999	Bridges		
6,065,609	A	*	5/2000	Lake	.....	210/474
D444,929	S	*	7/2001	Cox	.....	D7/536 X

**OTHER PUBLICATIONS**

Aladdin ® “Don’t Loose Your Temperature!”, 1993.  
 Aladdin ® “Good Taste Comes in All Sizes”, 1993.  
 Aladdin ® “Customized Beverageware”, 1995.  
 “Insulated Travel Mugs for Spring/Summer” brochure, 1995 (2pp.).  
 “The Traveller™ Car Mug” Brochure, 1995.  
 “1996 Centennial Olympic Collection” brochure, 1995.  
 Aladdin ® “Stanley® Insulated Travel Mug” brochure, 1995.  
 Aladdin ® “Stanley”® “Newspaper Ad Slicks” brochure, 1995.  
 Aladdin ® “Foam Insulated Mugs” brochure, 1995.  
 Aladdin ® “Car Go” brochure, 1995 (2 pp.).  
 Aladdin ® “Chill Out” brochure, 1995 (2 pp.).  
 Aladdin ® “10 ’N 10” brochure, 1995 (pp. 1–8 and cover page).

\* cited by examiner

*Primary Examiner*—M. N. Pandozzi  
(74) *Attorney, Agent, or Firm*—Greenblum & Bernstein, P.L.C.

(57) **CLAIM**

The ornamental design for a beverage mug, as shown and described.

**DESCRIPTION**

FIG. 1 is a perspective view of my new design;  
 FIG. 2 is a front elevational view thereof;  
 FIG. 3 is a left side elevational view thereof;  
 FIG. 4 is a right side elevational view thereof;  
 FIG. 5 is a top plan view thereof;  
 FIG. 6 is a bottom plan view thereof; and,  
 FIG. 7 is a cross section taken along line 7—7 of FIG. 5.

**1 Claim, 7 Drawing Sheets**

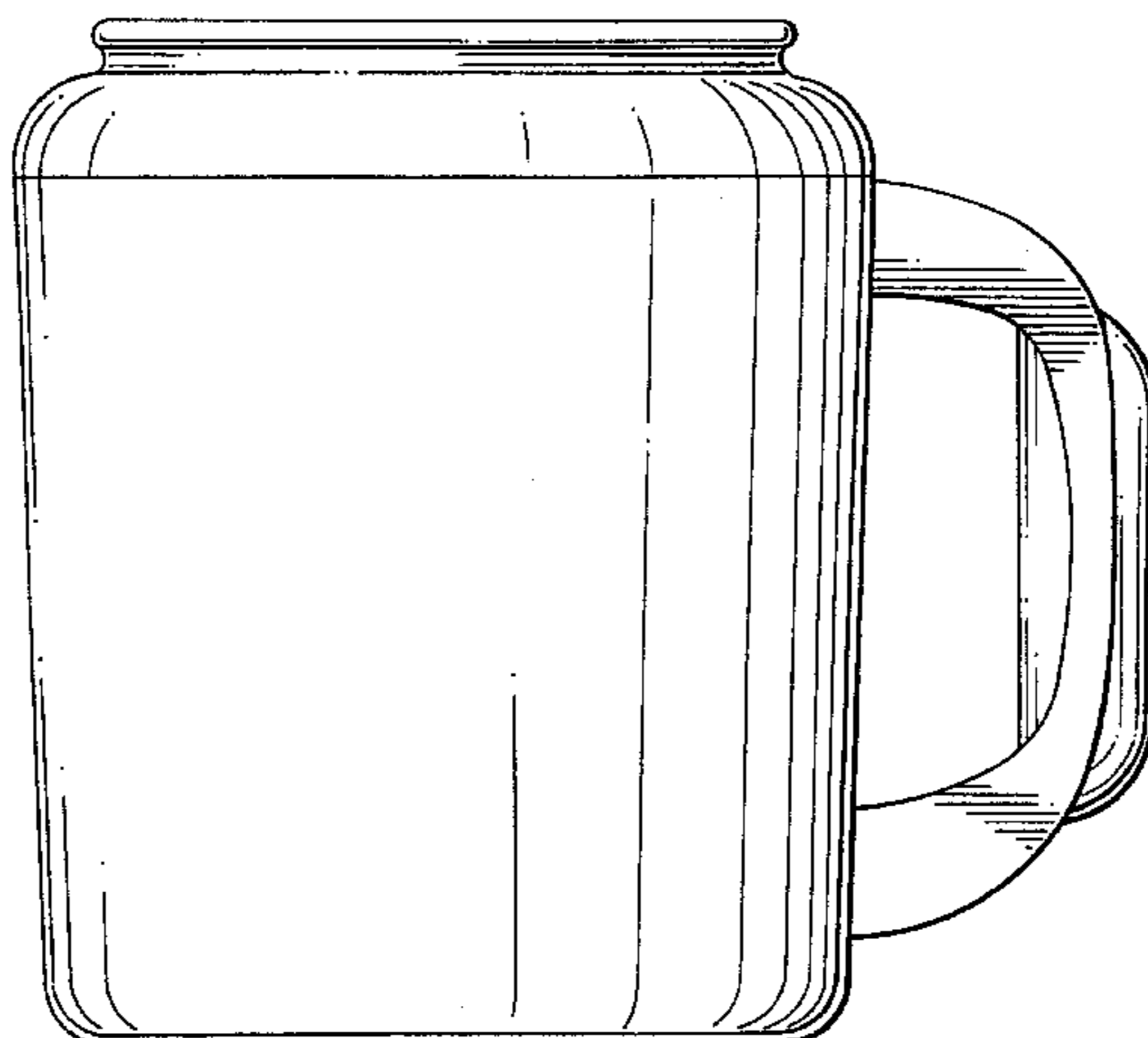

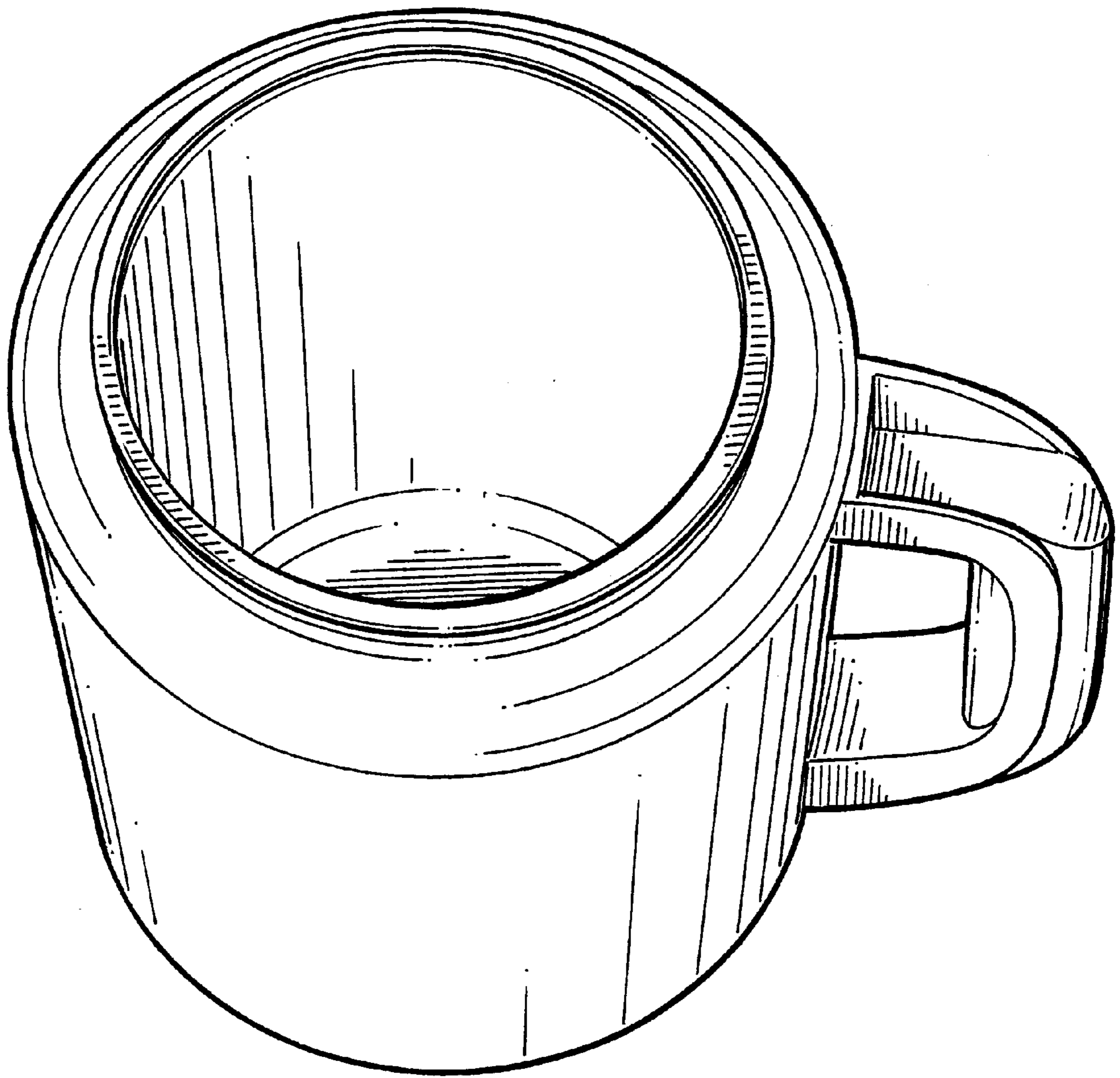

FIG. 1

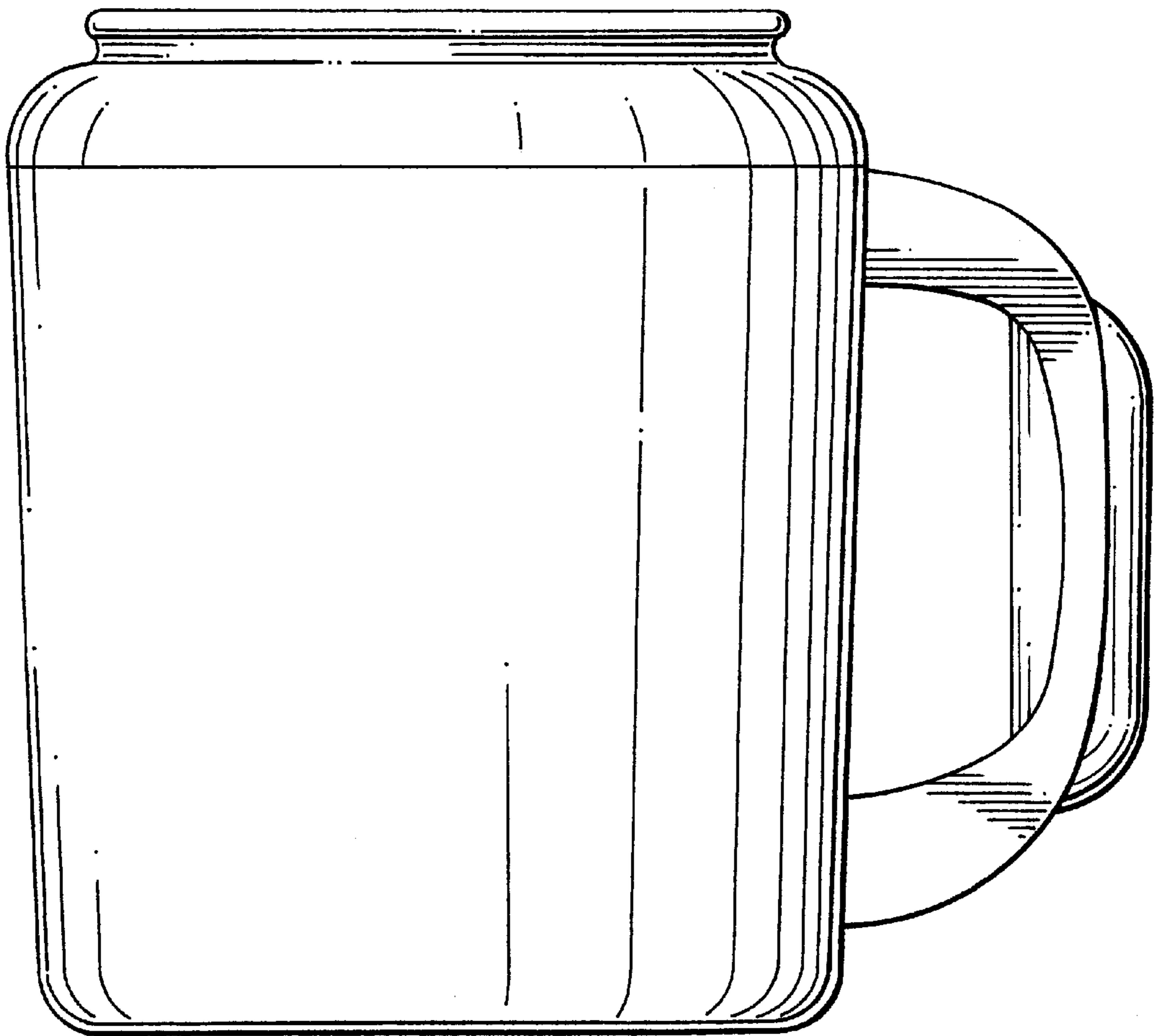

FIG. 2

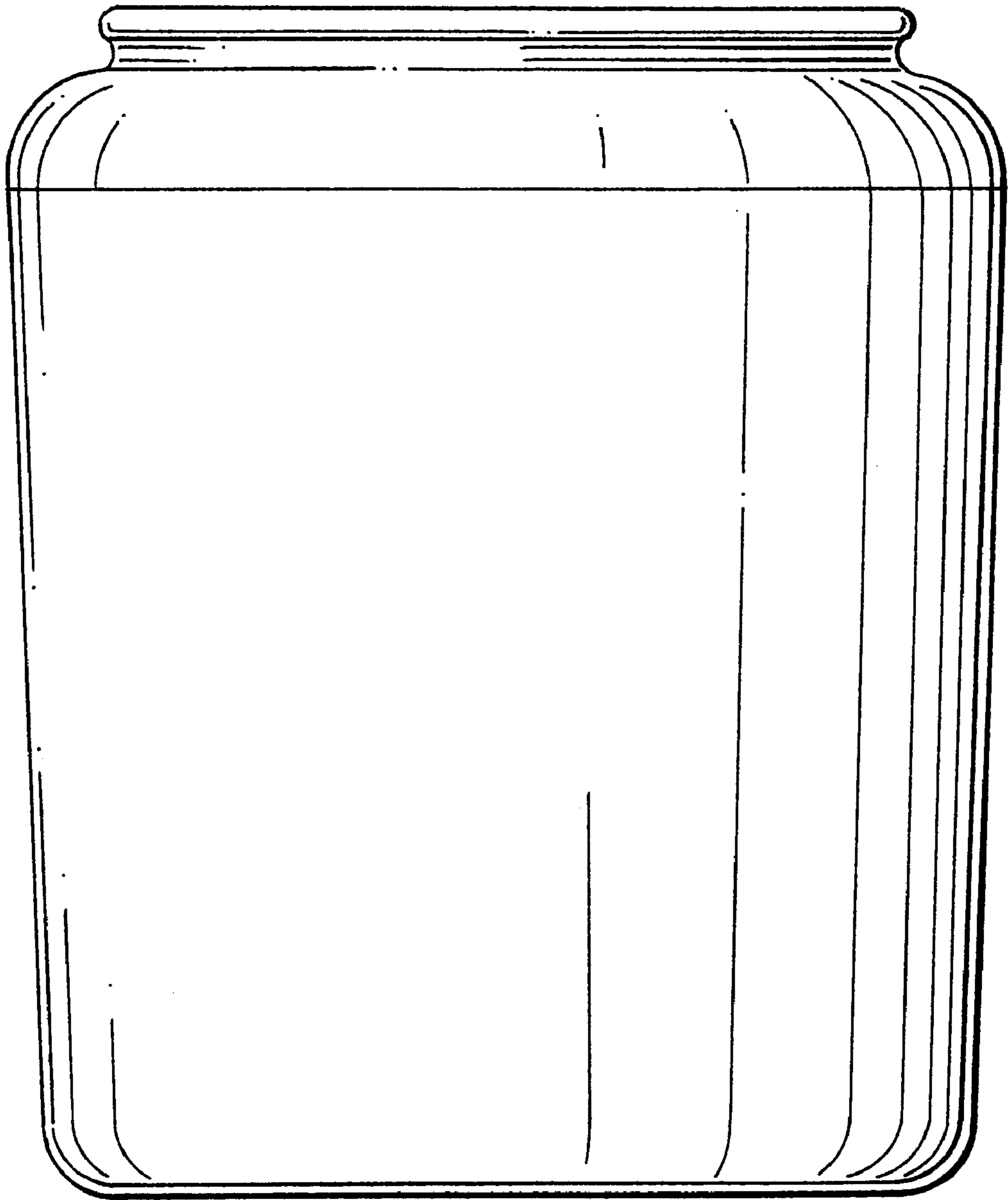

FIG. 3

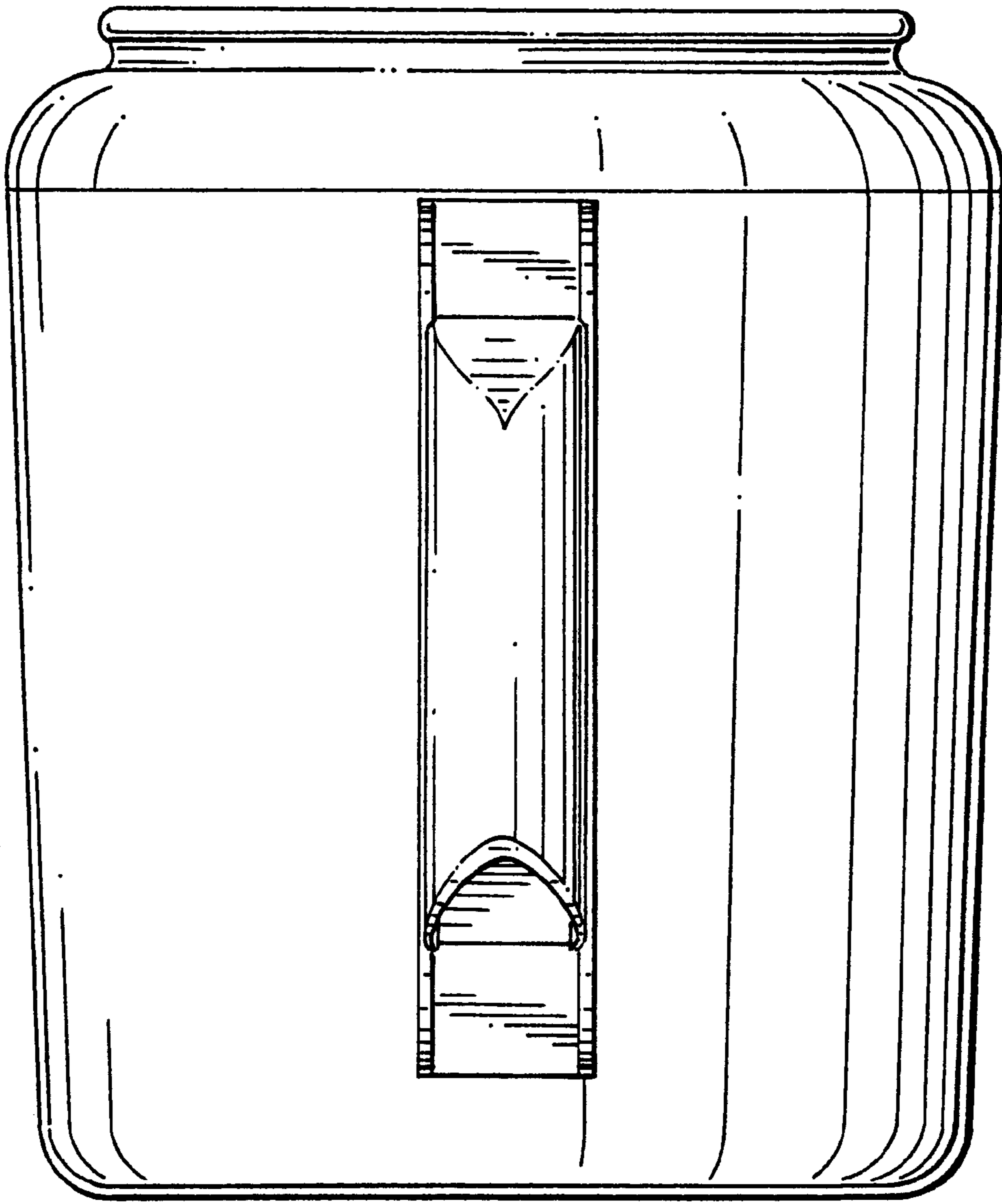

FIG. 4



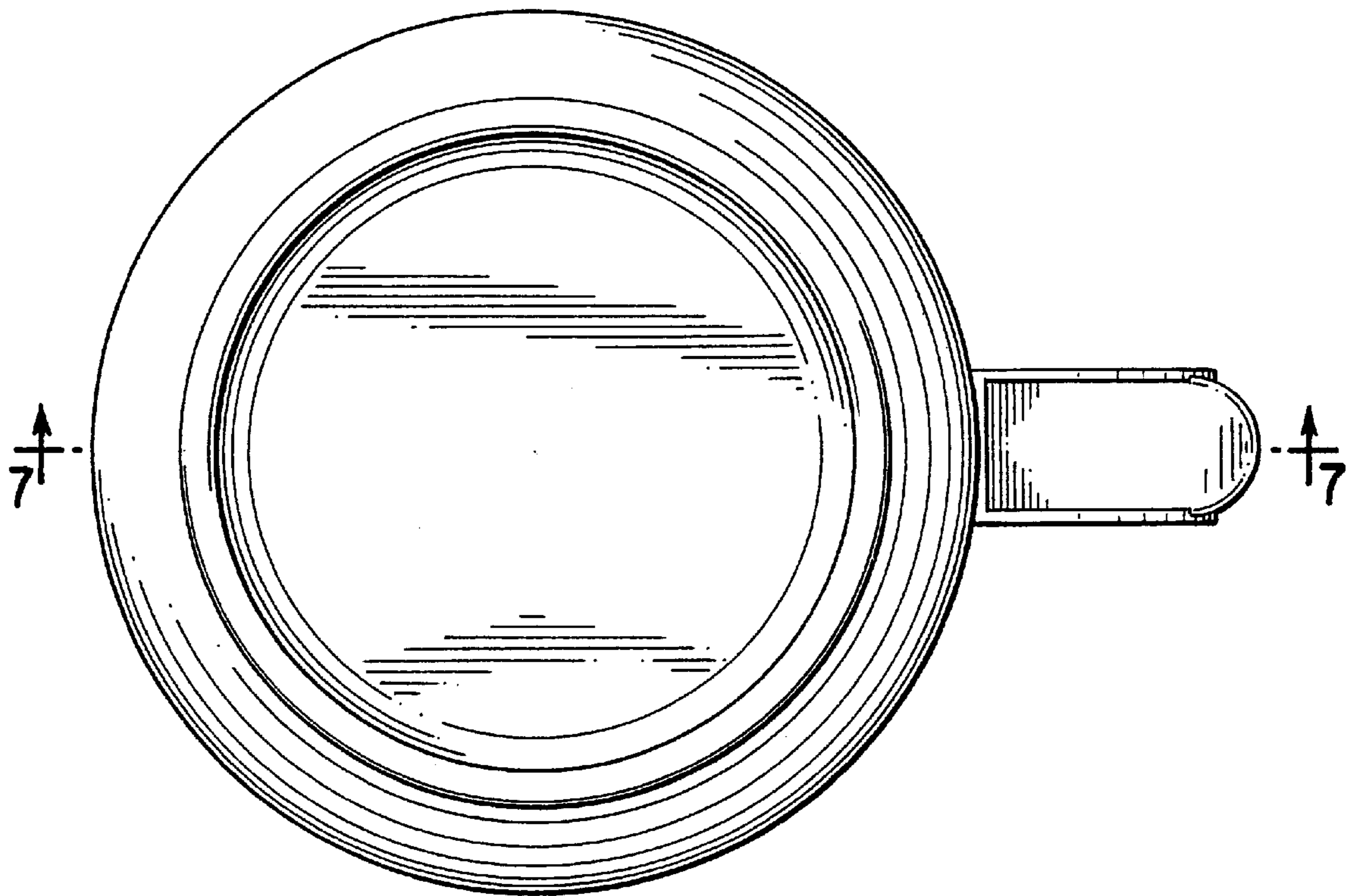

FIG. 5

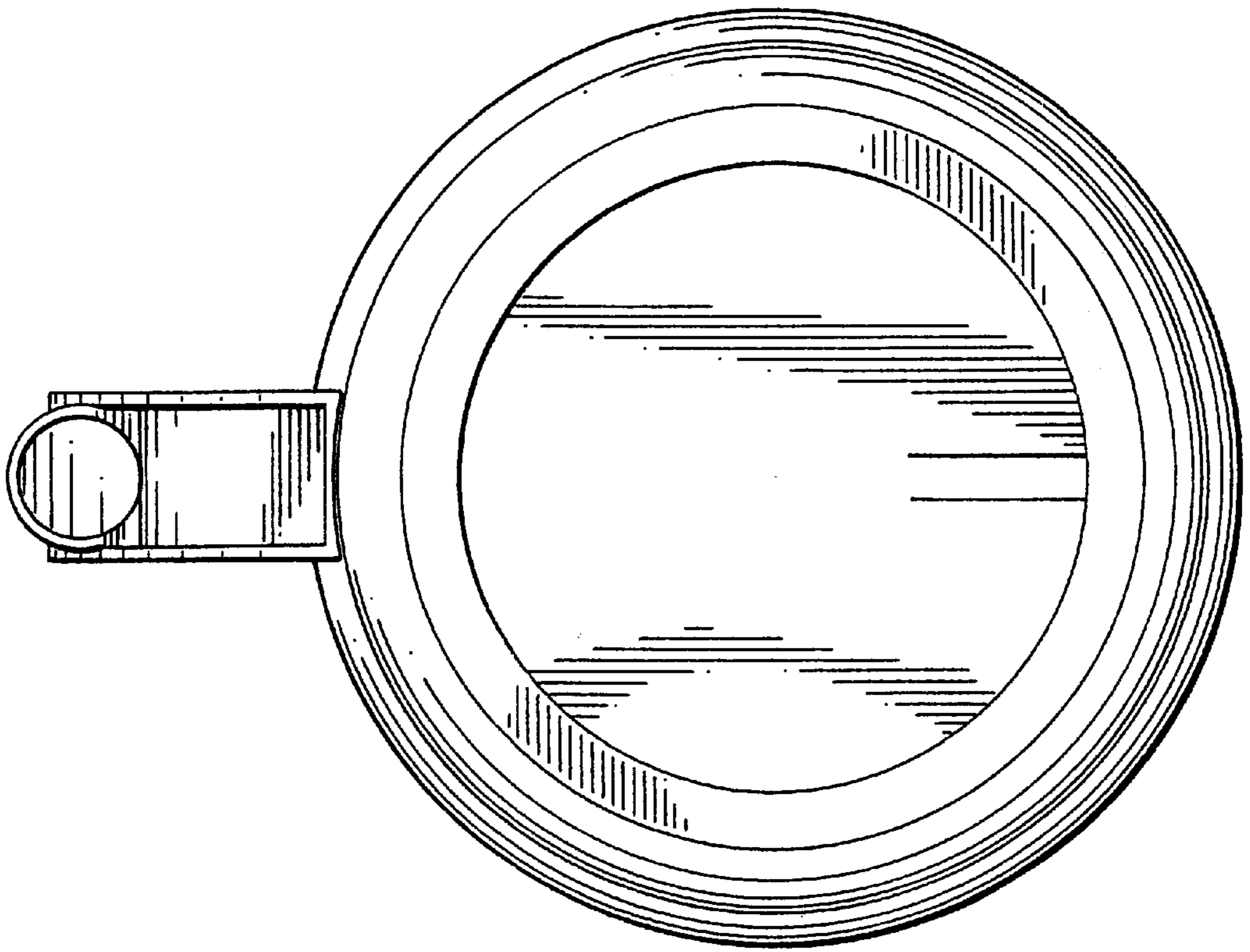

FIG. 6

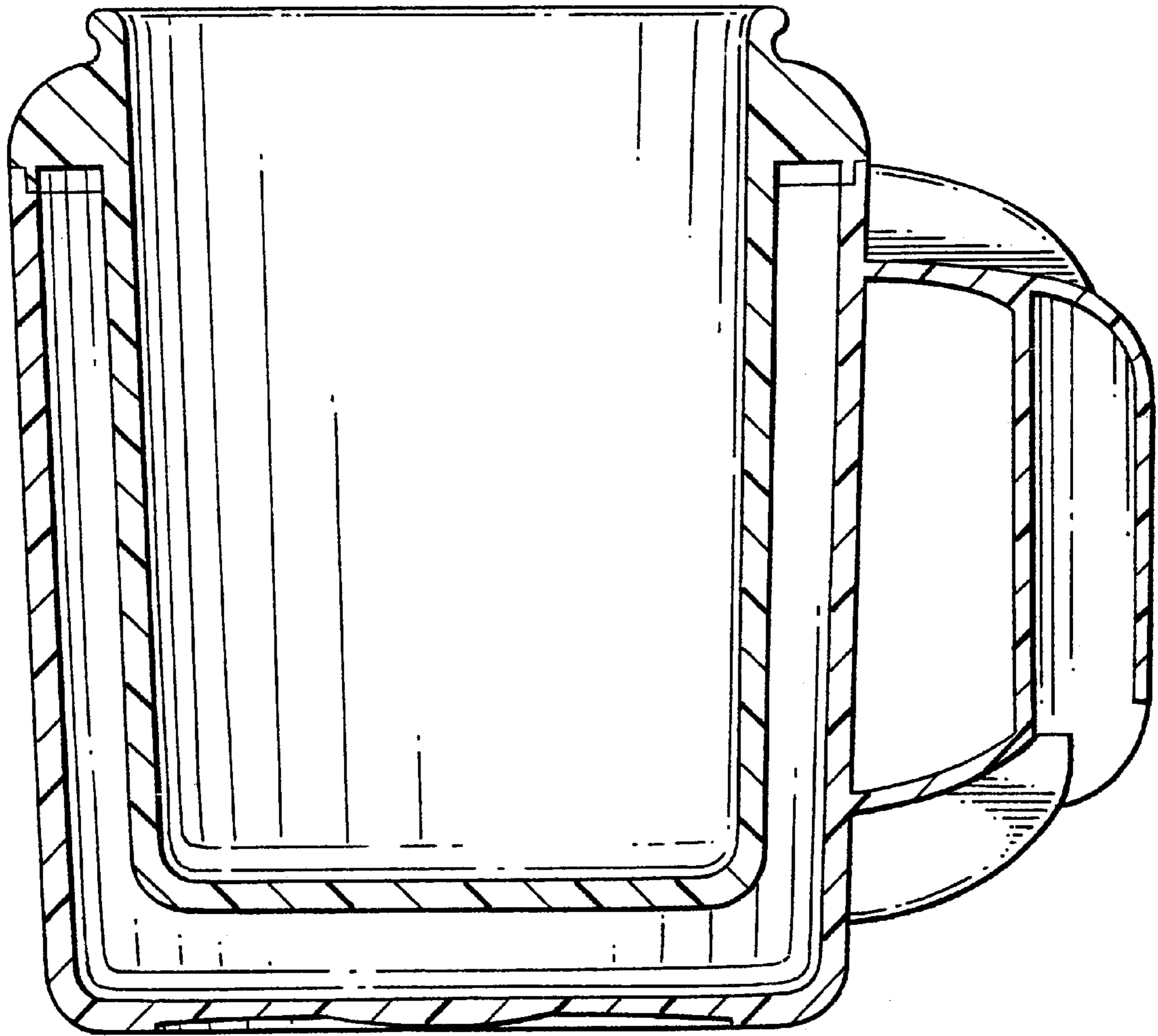

FIG. 7