



US00D455516S

(12) **United States Design Patent**
Casciani et al.

(10) **Patent No.:** **US D455,516 S**
(45) **Date of Patent:** **** Apr. 9, 2002**

(54) **LIGHTING FIXTURE**

(75) Inventors: **Stefano Casciani**, Milan (IT); **Susan Hakkarainen**, Doylestown, PA (US)

(73) Assignee: **Ivalo Lighting Inc.**, Doylestown, PA (US)

(**) Term: **14 Years**

(21) Appl. No.: **29/129,925**

(22) Filed: **Sep. 25, 2000**

(51) **LOC (7) Cl.** **26-05**

(52) **U.S. Cl.** **D26/76**

(58) **Field of Search** D26/75-79, 3,
D26/26, 118; 362/217, 218, 219, 220, 221,
222, 223

(56) **References Cited**

U.S. PATENT DOCUMENTS

2,429,141 A	*	10/1947	Taylor	D26/118 X
D149,655 S	*	5/1948	Lindahl	D26/75
4,876,633 A	*	10/1989	Engel et al.	362/223
D351,039 S	*	9/1994	Cole	D26/77

OTHER PUBLICATIONS

Lighting and Lamps, Aug. 1951, top, right Hall-Lite.*
Lighting, May 1954, fluorescent lamp. bottom right.*
Illuminotecnica, Nov./Dec. 1996, p. 201, bottom fluorescent lamp.*

* cited by examiner

Primary Examiner—Susan J. Lucas
(74) *Attorney, Agent, or Firm*—Ostrolenk, Faber, Gerb & Soffen, LLP

(57) **CLAIM**

The ornamental design for a lighting fixture, as shown and described.

DESCRIPTION

FIG. 1 is a perspective view of the of the first embodiment of the luminaire in an exemplary environment of use, namely as a ceiling fixture.

FIG. 2 is a perspective view of the under side of the luminaire shown in FIG. 1, showing a translucent blade that closes a longitudinal slot in the body.

FIG. 3 is a side view of the luminaire shown in FIG. 1.

FIG. 4 is a perspective view of one end of FIG. 3 as seen from above in which the body of the luminaire and a series of longitudinally spaced diffuser plates extending from the upper surface of the body are semi-circular.

FIG. 5 is a cross-sectional view of the luminaire taken along line 5—5 in FIG. 4.

FIG. 6 is a perspective view of a portion of the diffuser plate assembly shown in FIG. 4.

FIG. 7 is a perspective view similar to FIG. 4 showing a second embodiment of the luminaire of the present invention which differs from the first embodiment shown in FIGS. 1-6 in that the cross-section of the body is elliptical, and the individual diffuser plates are half-ellipses cut along the major axis thereof.

FIG. 8 is a cross-sectional view taken along line 8—8 in FIG. 7.

FIG. 9 is a perspective view similar to FIG. 6 showing a portion of the diffuser plate assembly of the second embodiment.

FIG. 10 is a perspective view similar to FIG. 4 showing a third embodiment of the luminaire of the present invention which differs from the first embodiment shown in FIGS. 1-6 in that the cross-section of the body is generally rectangular, and the individual diffuser plates are substantially rectangular.

FIG. 11 is a cross-sectional view taken along line 11—11 in FIG. 10.

FIG. 12 is a perspective view similar to FIG. 6 showing the diffuser plate assembly of the third embodiment.

FIG. 13 is a perspective view similar to FIG. 4 showing a fourth embodiment of the luminaire of the present invention which differs from the first embodiment shown in FIGS. 1-6 in that the cross-section of the body and the individual diffuser plates are in the shape of one-half of a geometric figure having more than four sides, e.g., half-octagons.

FIG. 14 is a cross-sectional view taken along line 14—14 in FIG. 13.

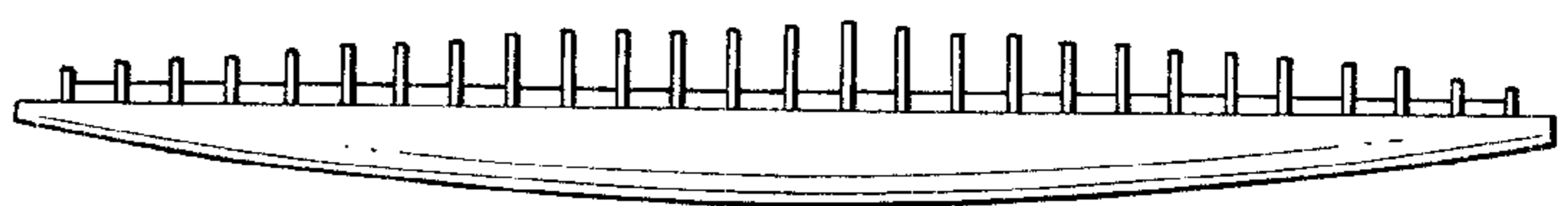
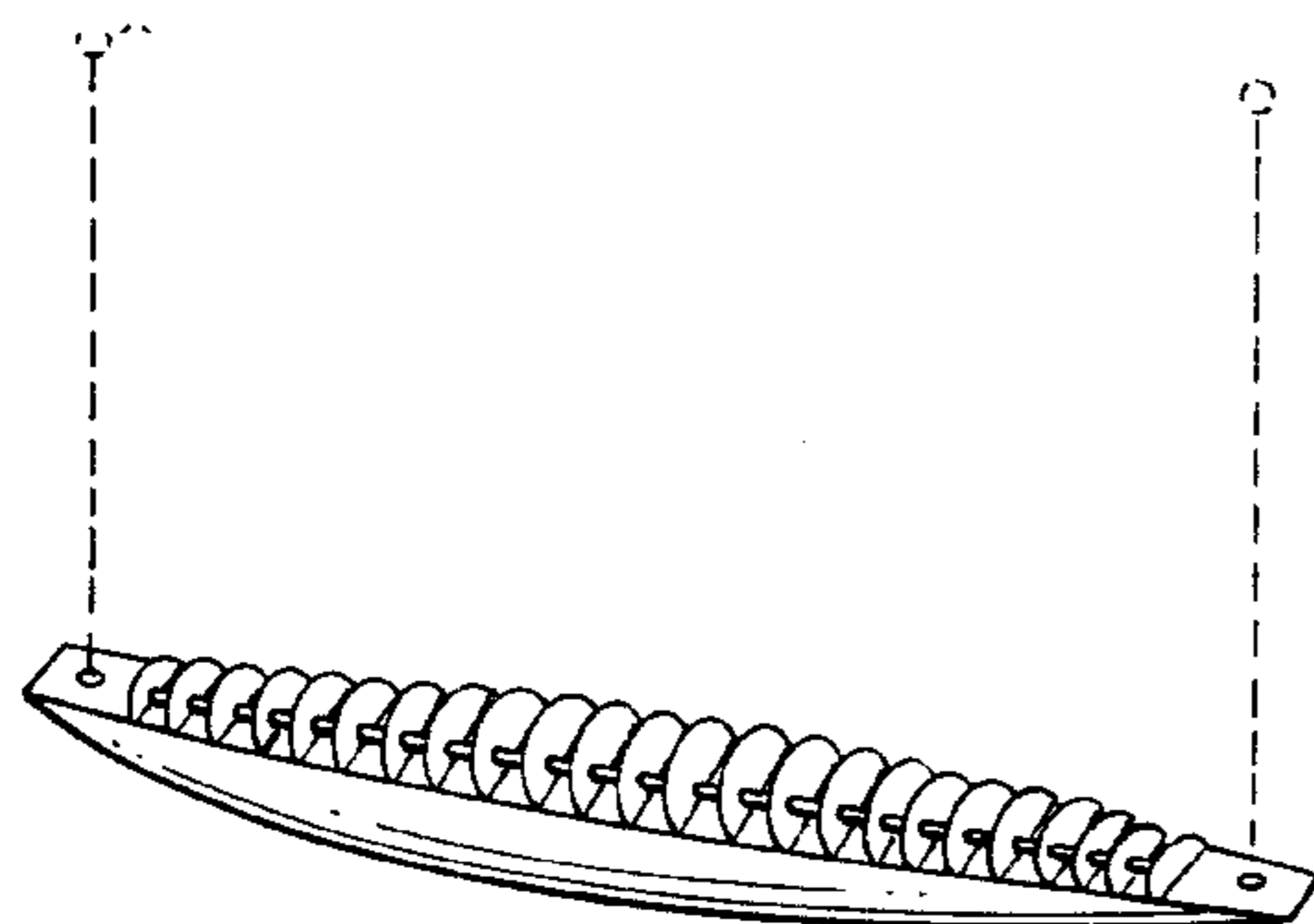

FIG. 15 is a perspective view similar to FIG. 6 showing a portion of the diffuser plate assembly of the fourth embodiment.

FIG. 16 is a perspective view similar to FIG. 4 showing a fifth embodiment of the luminare of the present invention which differs from the first embodiment shown in FIGS. 1–6 in that cross-section of the body is a truncated triangle and the individual diffuser plates are triangles.

FIG. 17 is a cross-sectional view taken along line 17—17 in FIG. 16.

FIG. 18 is a perspective view similar to FIG. 6 showing a portion of the diffuser plate assembly of the fifth embodiment.

FIG. 19 is a perspective view similar to FIG. 10 showing a sixth embodiment of the luminare of the present invention which differs from the third embodiment shown in FIGS. 10–12 in that the rectangular diffuser plates do not project beyond the open face of the body.

FIG. 20 is a cross-sectional view taken along line 20—20 in FIG. 19.

FIG. 21 is a perspective view similar to FIG. 12 showing the diffuser plate assembly of the sixth embodiment.

FIG. 22 is a perspective view similar to FIG. 4 showing a seventh embodiment of the luminare of the present invention which differs from the first embodiment shown in FIGS. 1–6 in that the cross-section of the body is trapezoidal and the individual diffuser plates are trapezoidal.

FIG. 23 is a cross-sectional view taken along line 23—23 in FIG. 22.

FIG. 24 is a perspective view similar to FIG. 6 showing a portion of the diffuser plate assembly of the seventh embodiment.

FIG. 25 is a top view showing an eighth embodiment of the luminare of the present invention which differs from the first embodiment shown in FIGS. 1–6 in that the diffuser plates have been replaced by a translucent flat plate which covers the body cavity, e.g., a screen.

FIG. 26 is a side view similar to FIG. 3 showing a ninth embodiment of the luminare of the present invention which differs from the first embodiment shown in FIGS. 1–6 in that the diffuser plates all project an equal distance above the body cavity.

FIG. 27 is a side view similar to FIG. 3 showing a tenth embodiment of the luminare of the present invention which differs from the ninth embodiment shown in FIG. 26 in that the diffuser plates project from the body cavity at an angle.

FIG. 28 is a cross-sectional view similar to FIG. 23 showing an eleventh embodiment of the luminare of the present invention which differs from the seventh embodiment shown in FIGS. 22–24 in that cross-section of the body and the individual diffuser plates are trapezoidal, but have concave, rather than straight sides.

FIG. 29 is a cross-sectional view similar to FIG. 28 showing a twelfth embodiment of the luminare of the present invention which differs from the eleventh embodiment shown in FIG. 28 in that the top of the body and the individual diffuser plates are trapezoidal, but have convex, rather than concave sides.

FIG. 30 is a perspective view similar to FIG. 2 showing a thirteenth embodiment of the luminare of the present invention which differs from the first embodiment shown in FIGS. 1–6 in that the blade which closes the longitudinal slot on the underside of the body projects outwardly beyond the slot.

FIG. 31 is a cross-sectional view taken along line 31—31 in FIG. 30.

FIG. 32 is a perspective view similar to FIG. 2 showing a fourteenth embodiment of the luminare of the present invention which differs from the thirteenth embodiment shown in FIGS. 30 and 31 in that the diffuser that closes the longitudinal slot is recessed within the slot.

FIG. 33 is a cross-sectional view taken along line 33—33 in FIG. 32.

FIG. 34 is a cross-sectional view similar to FIG. 31 showing a fifteenth embodiment of the luminare of the present invention which differs from the thirteenth embodiment shown in FIGS. 30 through 31 in that the diffuser that closes the longitudinal slot is formed of transversely spaced longitudinally extending convex ribs separated by a longitudinally extending concave slot.

FIG. 35 is a cross-sectional view similar to FIG. 31 showing a sixteenth embodiment of the luminare of the present invention which differs from the thirteenth embodiment shown in FIGS. 30 and 31 in that the diffuser blade has a longitudinally extending triangular notch on the projecting face thereof.

FIG. 36 is a cross-sectional view similar to FIG. 31 showing a seventeenth embodiment of the luminare of the present invention which differs from the thirteenth embodiment shown in FIGS. 30 and 31 in that the diffuser blade has a plurality of transversely spaced longitudinal ribs on the projecting face thereof.

FIG. 37 is a cross-sectional view similar to FIG. 31 showing an eighteenth embodiment of the luminare of the present invention which differs from the seventeenth embodiment shown in FIG. 36 in that the diffuser blade has a plurality of longitudinally extending sawtooth-shaped ribs on the downwardly projecting face thereof.

FIG. 38 is a cross-sectional view similar to FIG. 5 showing a nineteenth embodiment of the luminare of the present invention which differs from the first embodiment shown in FIGS. 1–6 in that the bottom face of the rectangular body includes a pair of spaced longitudinal slots each closed by a diffuser plate.

FIG. 39 is a cross-sectional view similar to FIG. 23 showing a twentieth embodiment of the luminare of the present invention which differs from the seventh embodiment shown in FIGS. 22–24 in that the bottom face of the trapezoidal body includes a pair of spaced longitudinal slots, each closed by a diffuser plate.

FIG. 40 is a cross-sectional view similar to FIG. 29 showing a twenty-first embodiment of the luminare of the present invention which differs from the twelfth embodiment shown in FIG. 29 in that the bottom face of the body includes a pair of spaced longitudinal slots, each closed by a diffuser plate.

FIG. 41 is a perspective view similar to FIG. 2 showing a twenty-second embodiment of the luminare of the present invention which differs from the first embodiment shown in FIGS. 1–6 in that the undersurface of the body includes a series of radial bores therethrough creating point sources of illumination along the length of the body.

FIG. 42 is a perspective view similar to FIG. 41 showing a twenty-third embodiment of the luminaire of the present invention which differs from the twenty-second embodiment shown in FIG. 41 in that the diffuser blade covering the slot in the undersurface of the body includes a series of radial bores therethrough creating point sources of illumination along the length thereof.

FIG. 43 is a perspective view similar to FIG. 41 showing a twenty-fourth embodiment of the luminaire of the present invention which differs from the twenty-third embodiment shown in FIG. 42 in that the diffuser blade covering the slot in the undersurface of the body includes a series of longi

tudinally spaced transverse slots therethrough creating line sources of illumination along the length thereof; and,

FIG. 44 cross-sectional view similar to FIG. 5 showing a twenty-fifth embodiment of the luminaire of the present invention which differs from the first embodiment shown in FIGS. 1-6 in that the body of the luminaire and the diffuser plates are not of like configuration, e.g., the body is semi-circular and the diffuser plates are triangular.

1 Claim, 10 Drawing Sheets

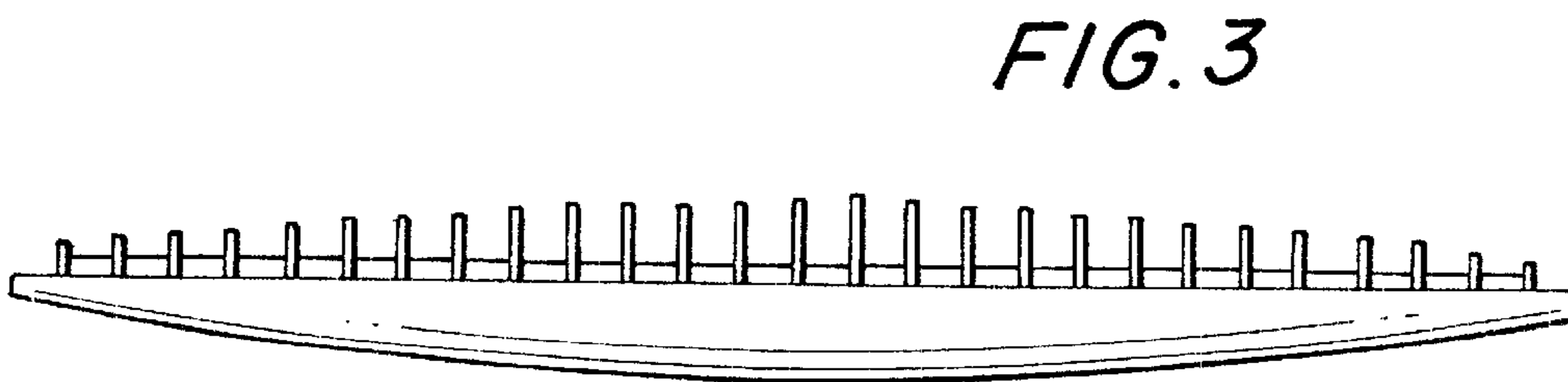
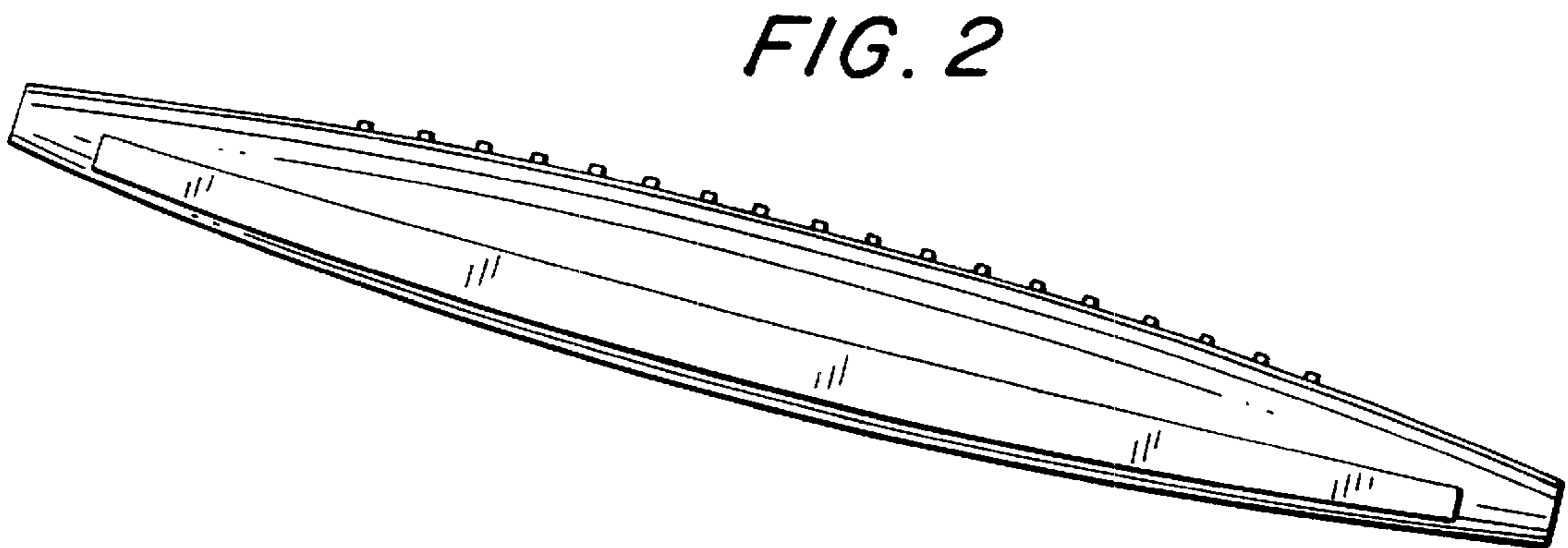
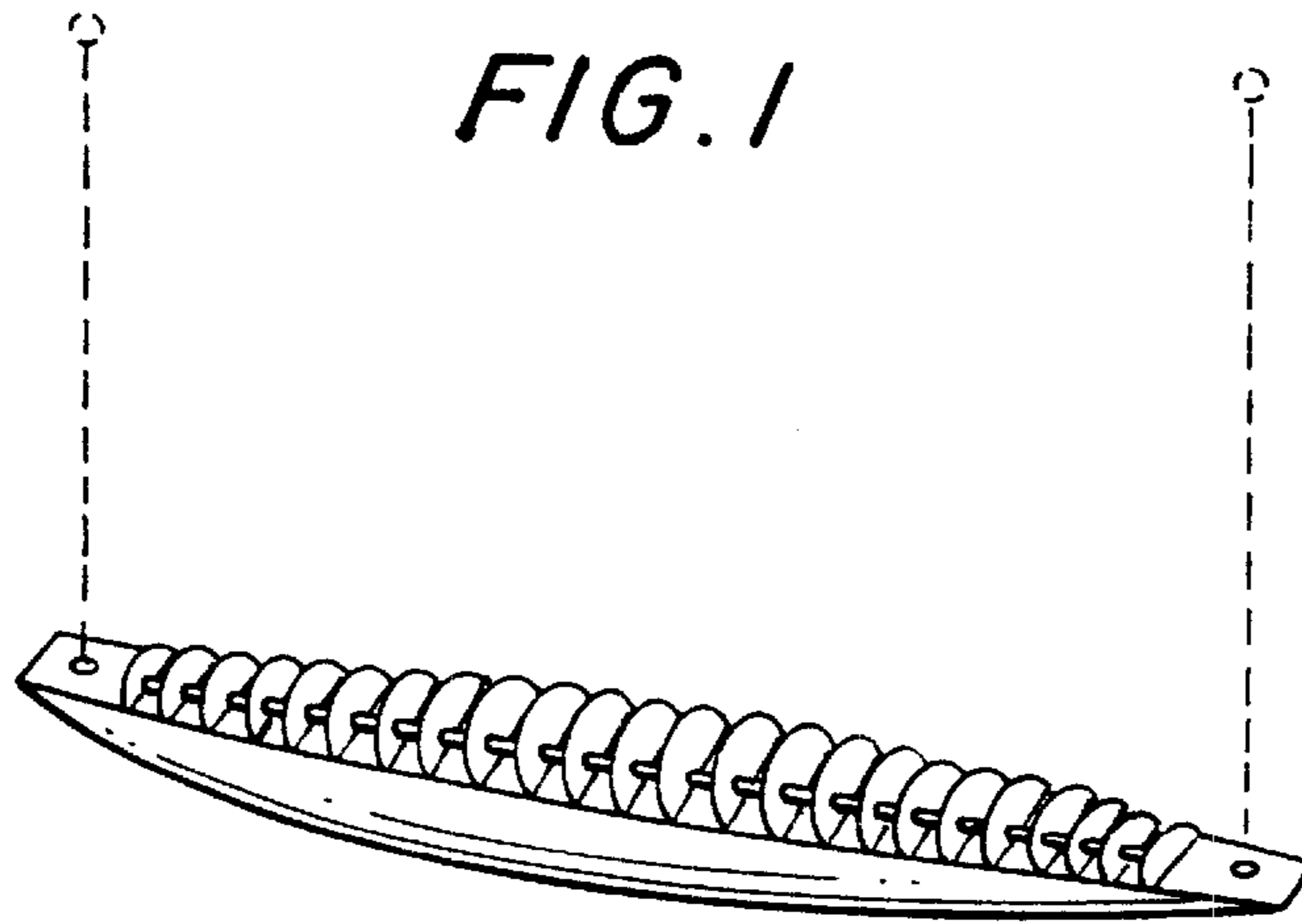

FIG. 4

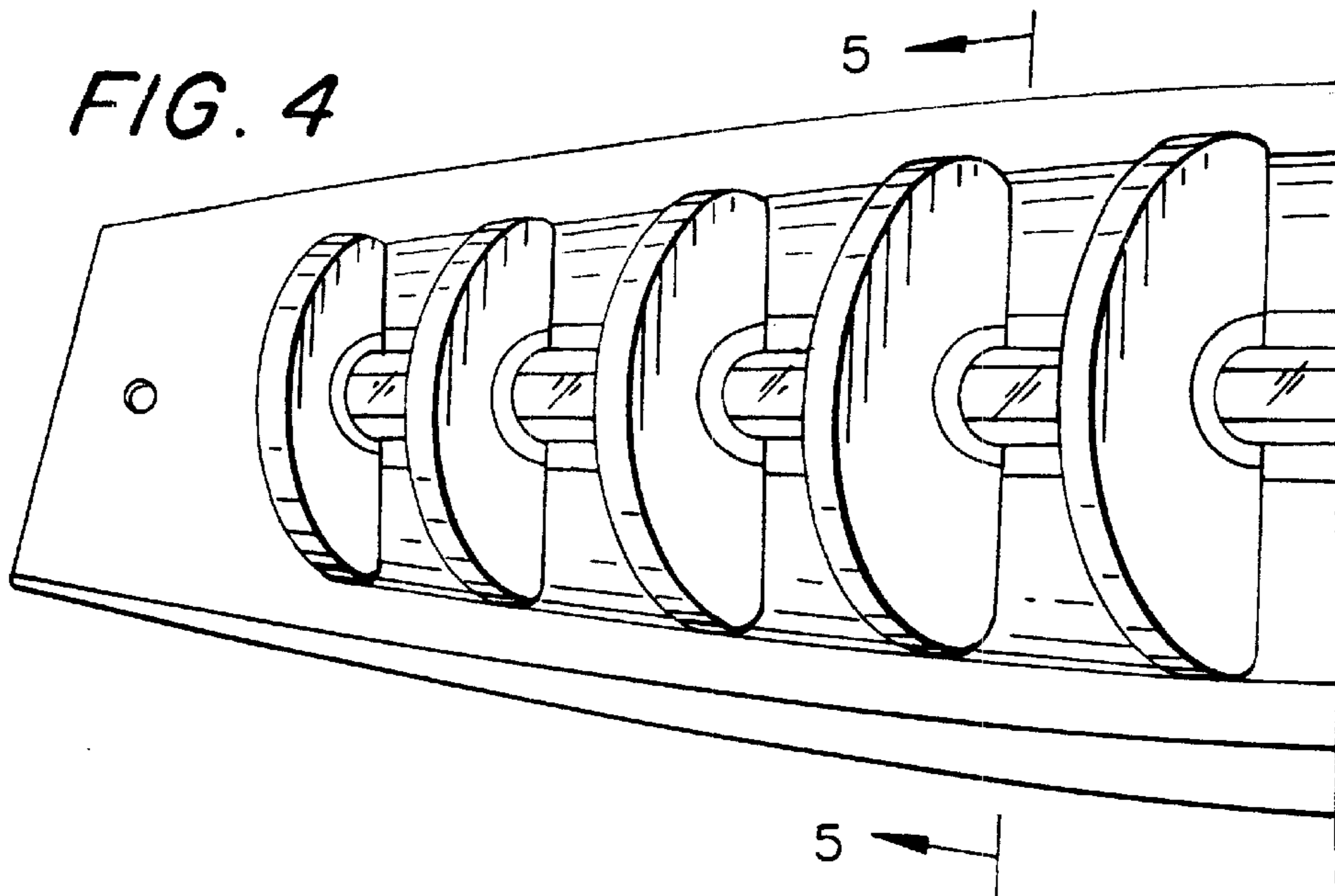

FIG. 5

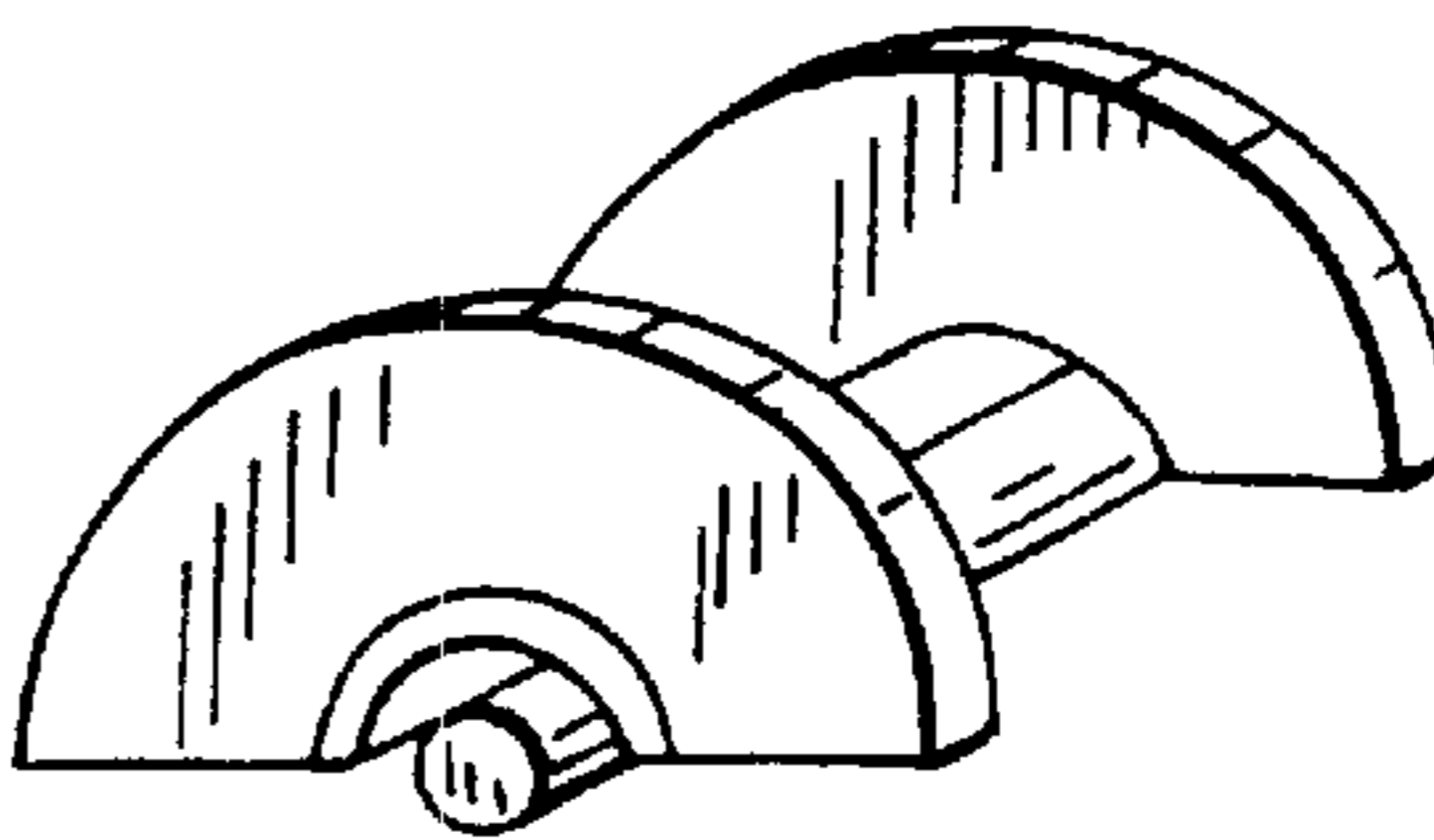
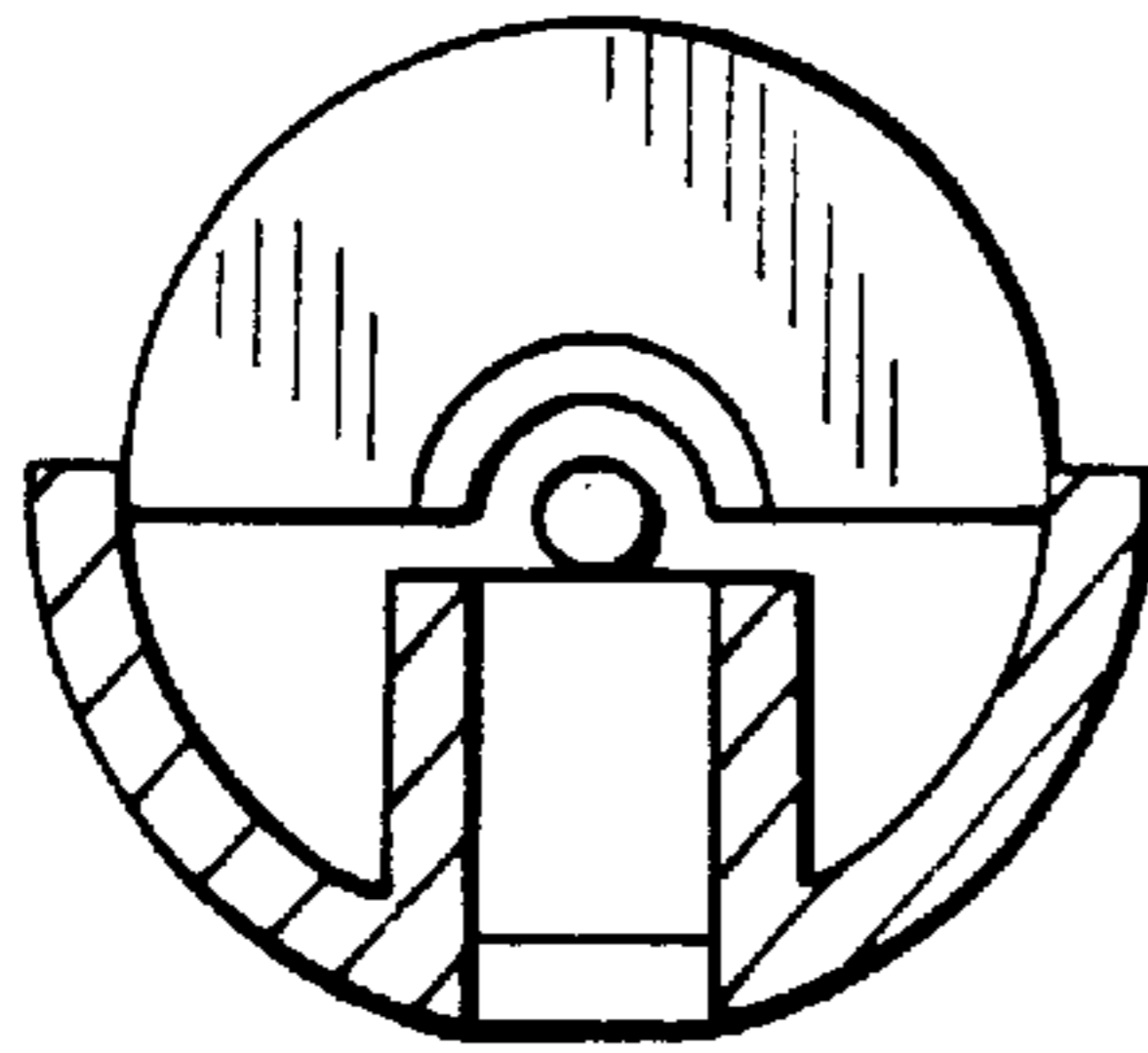
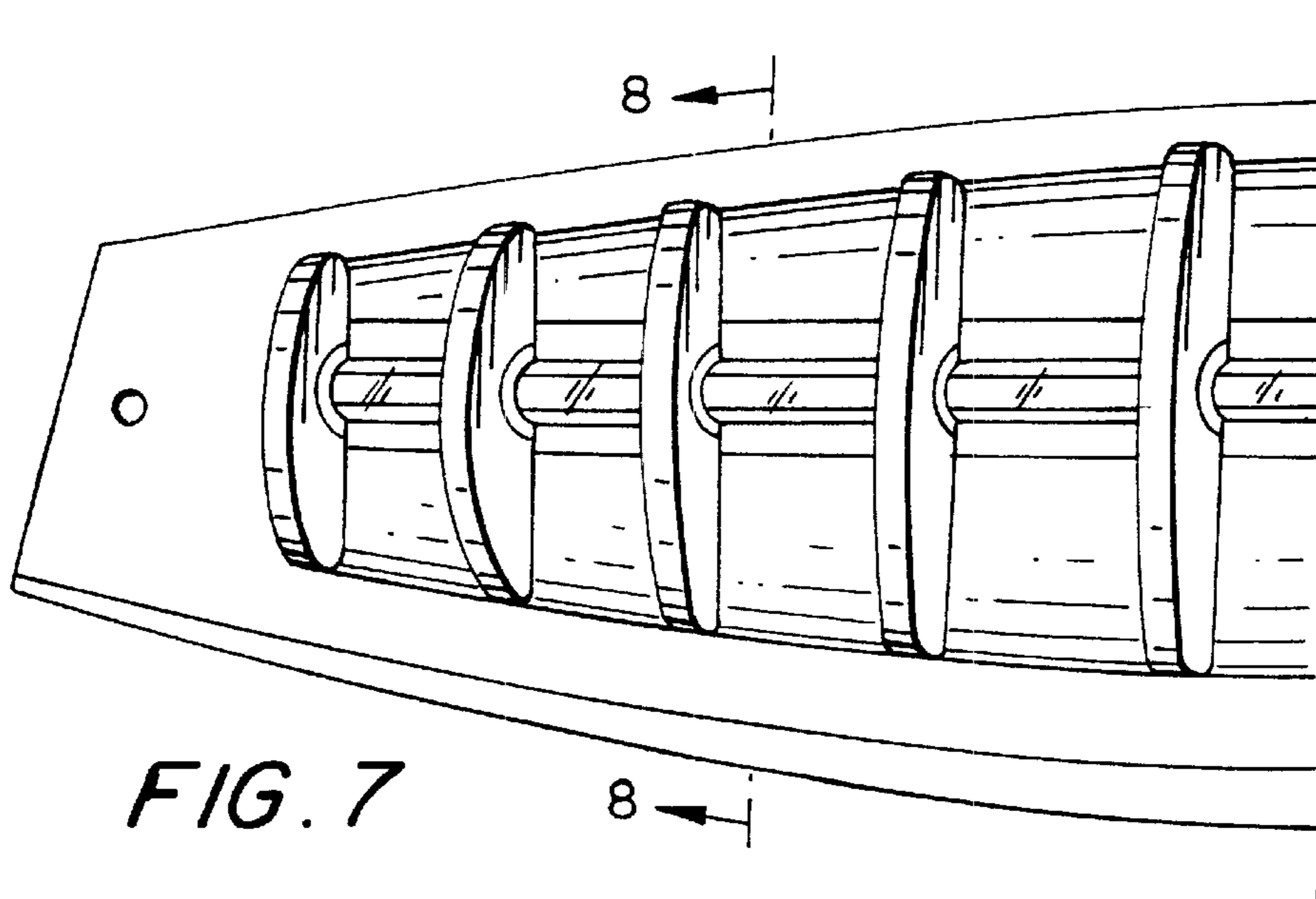
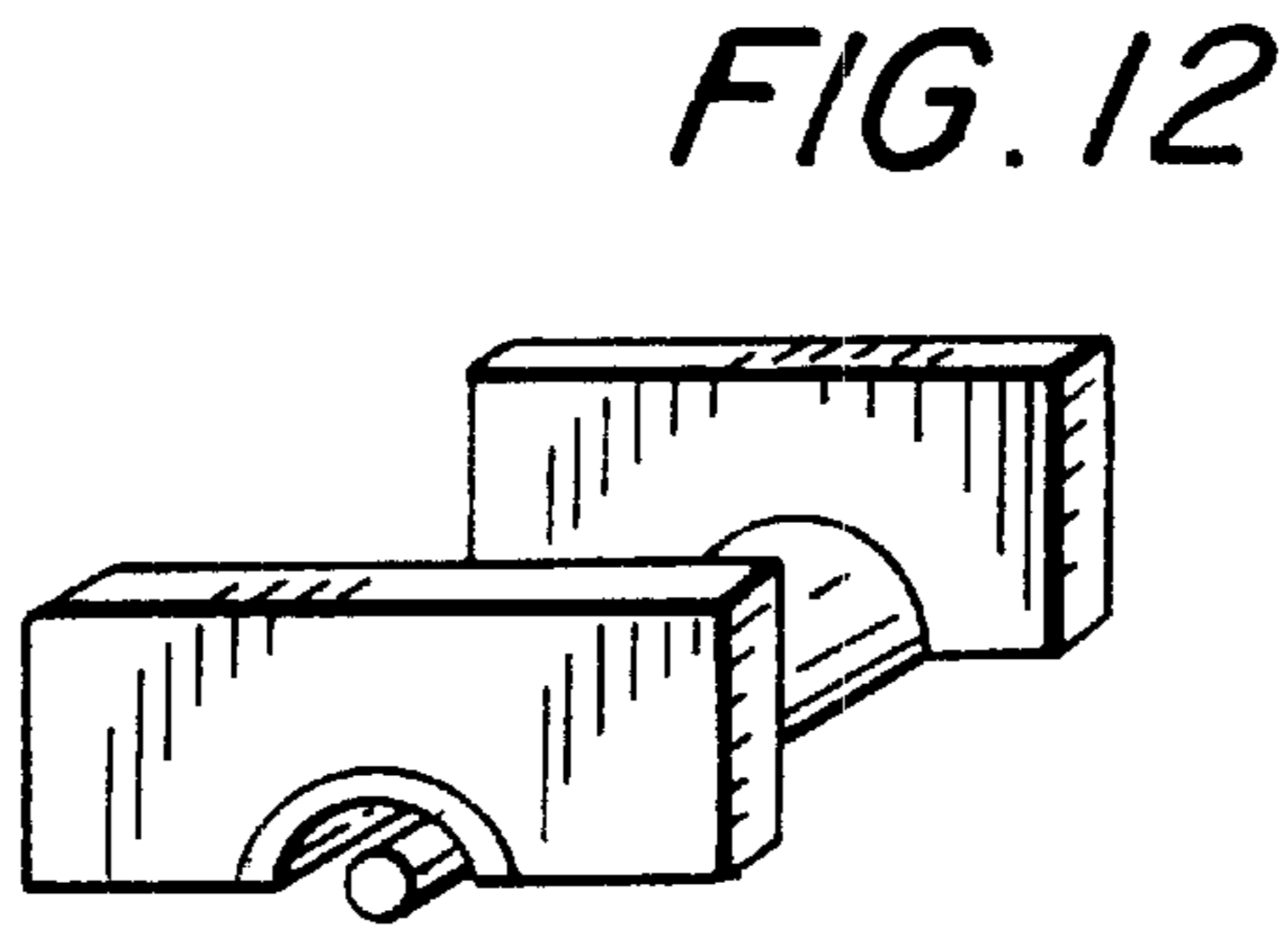
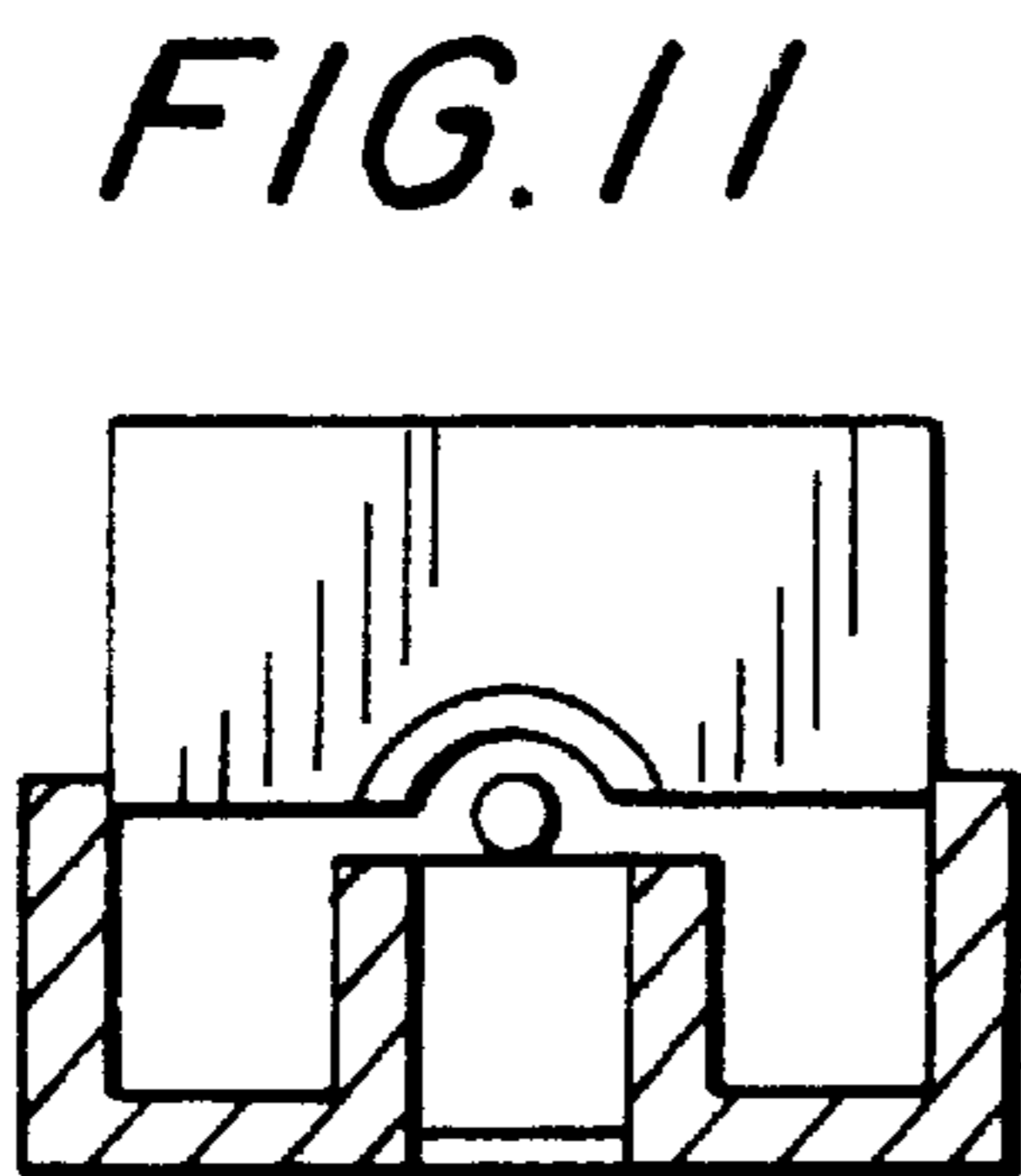
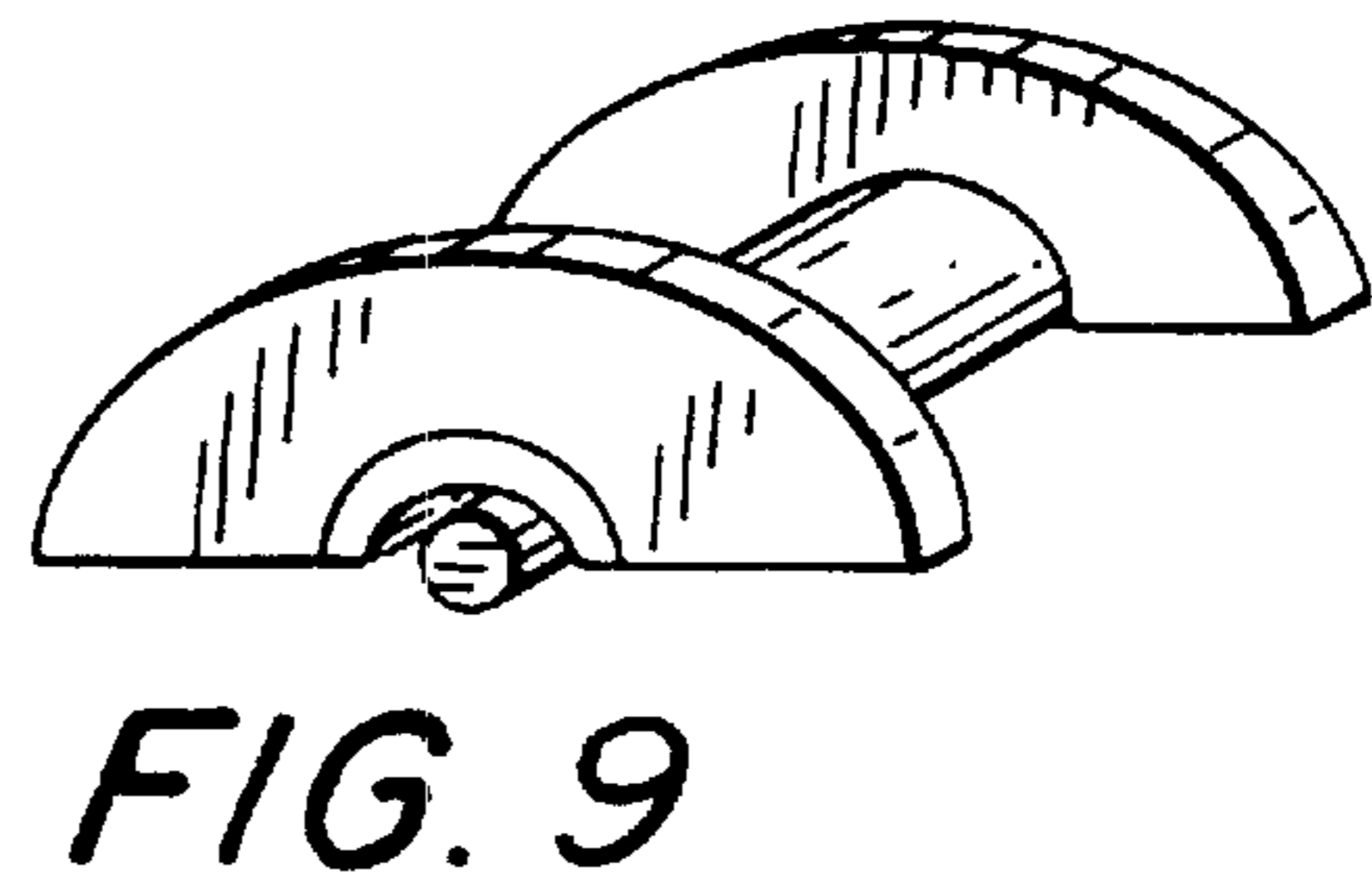
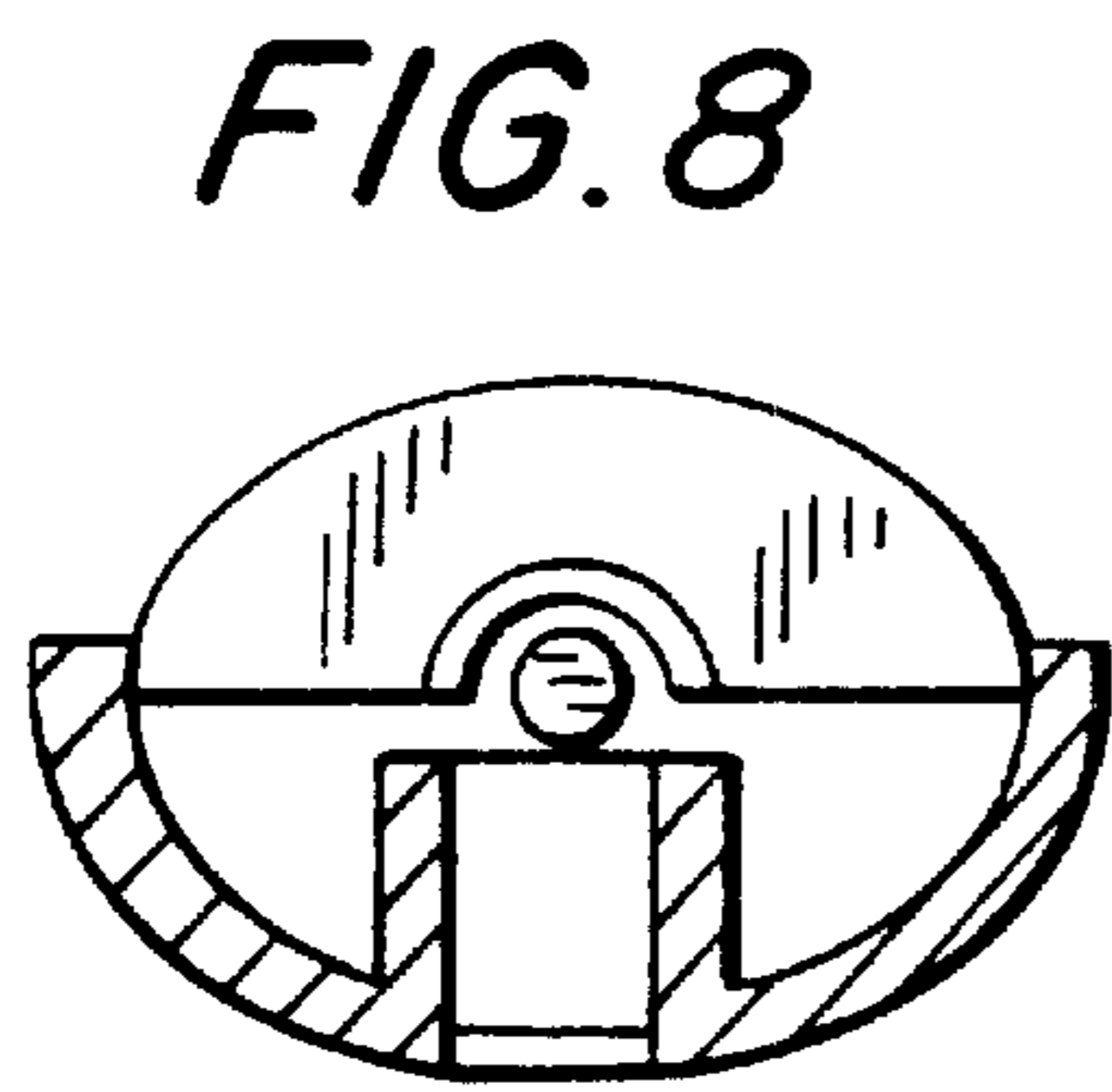
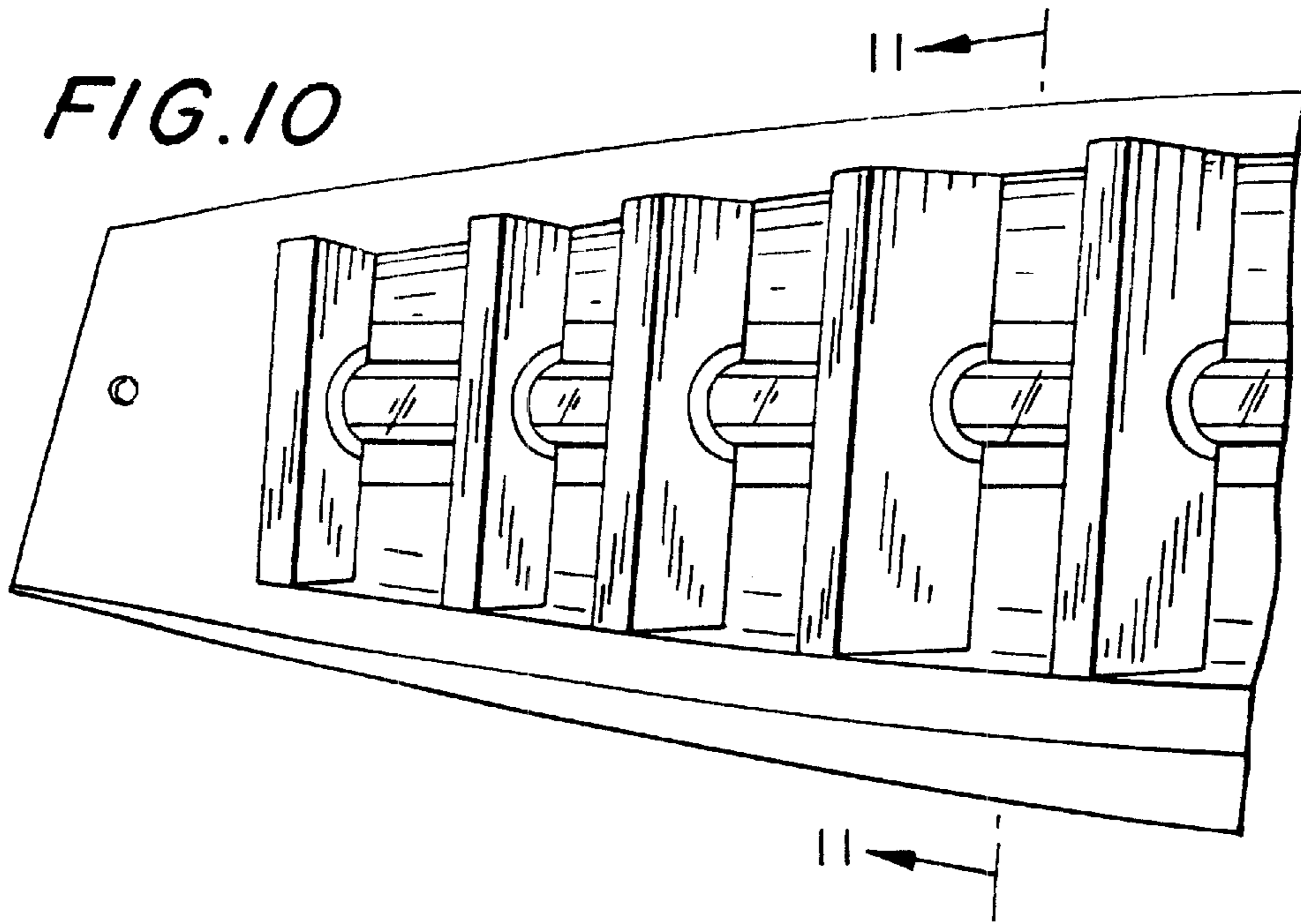

FIG. 6

FIG. 7





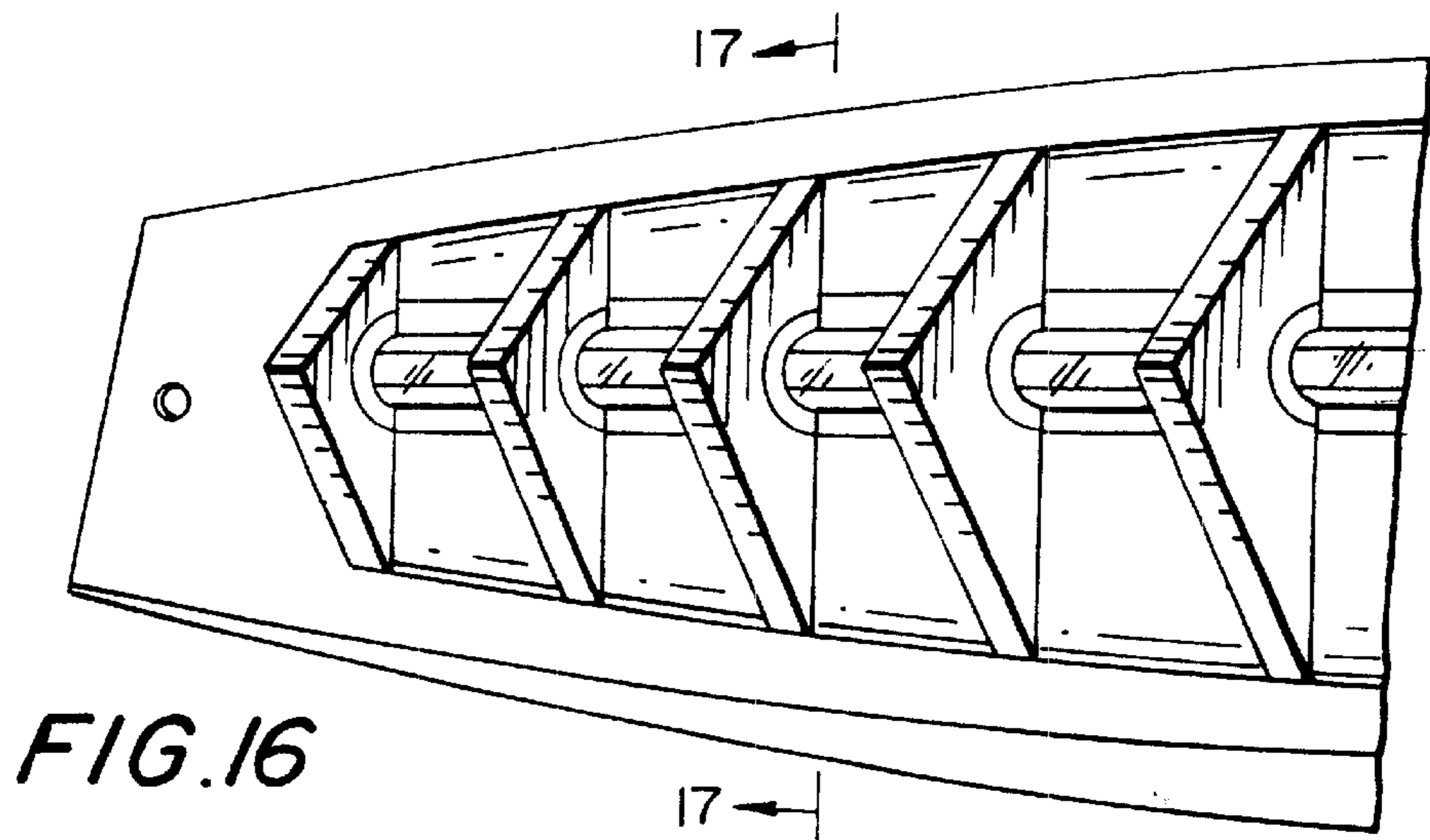
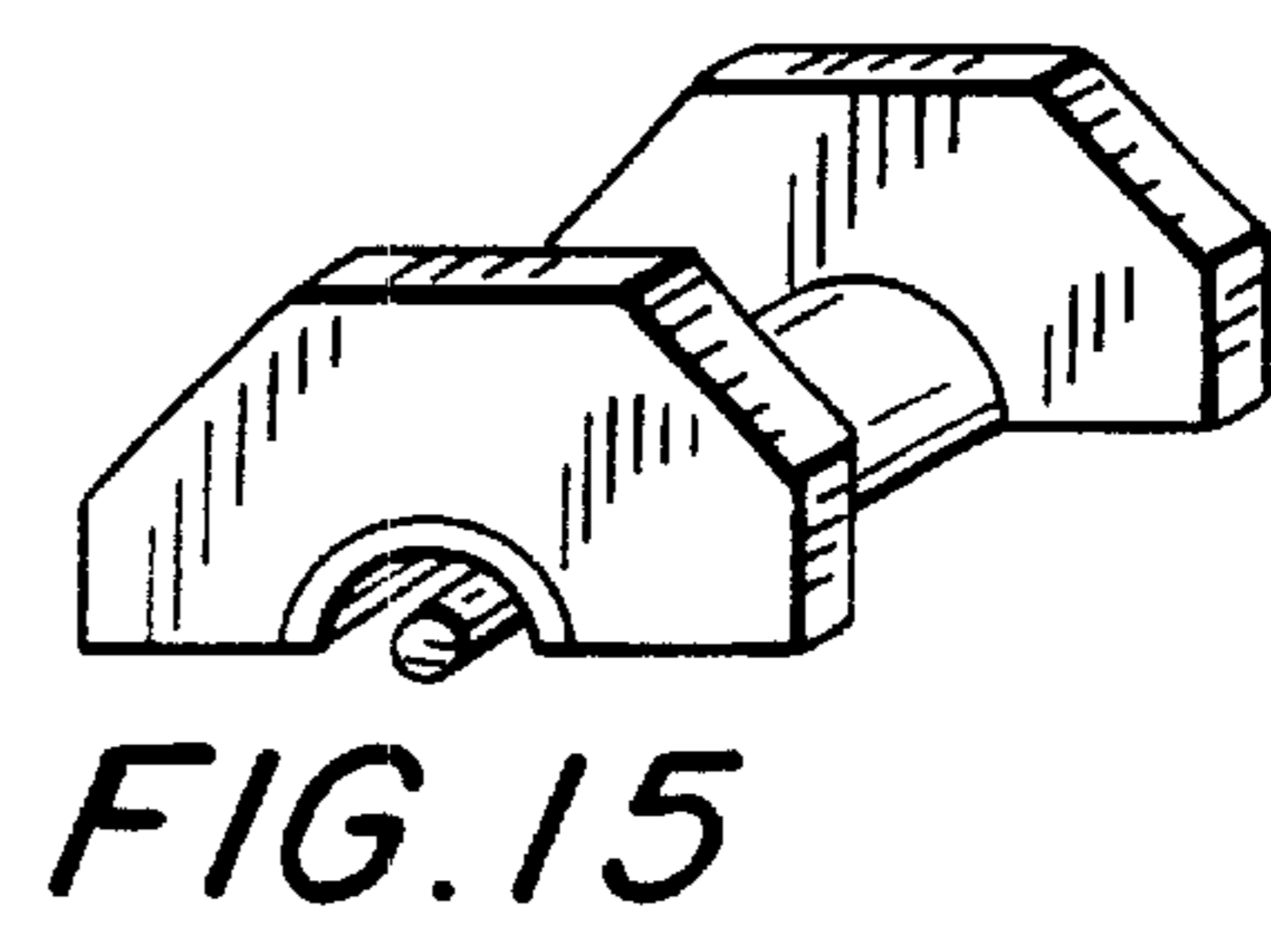
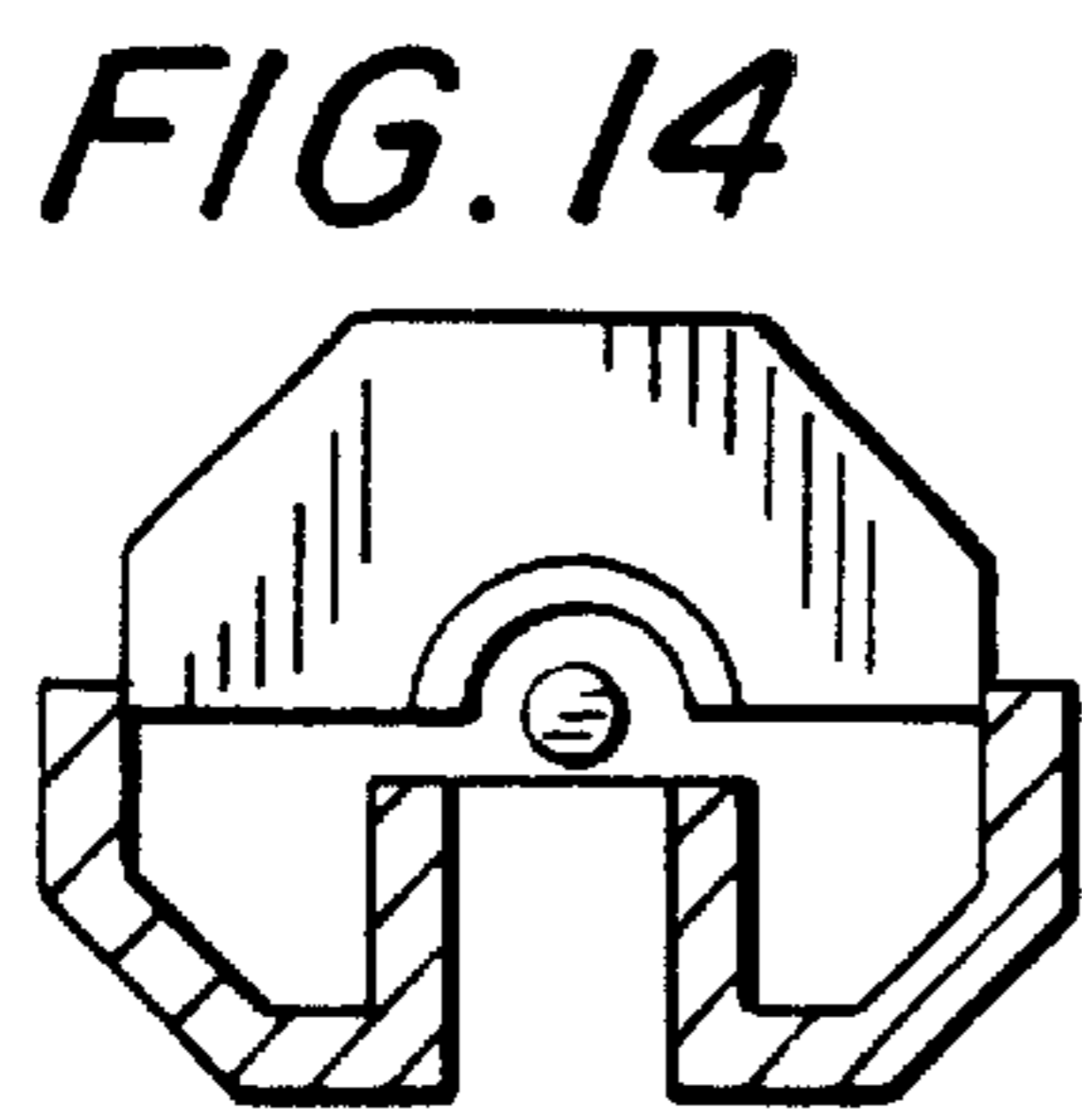
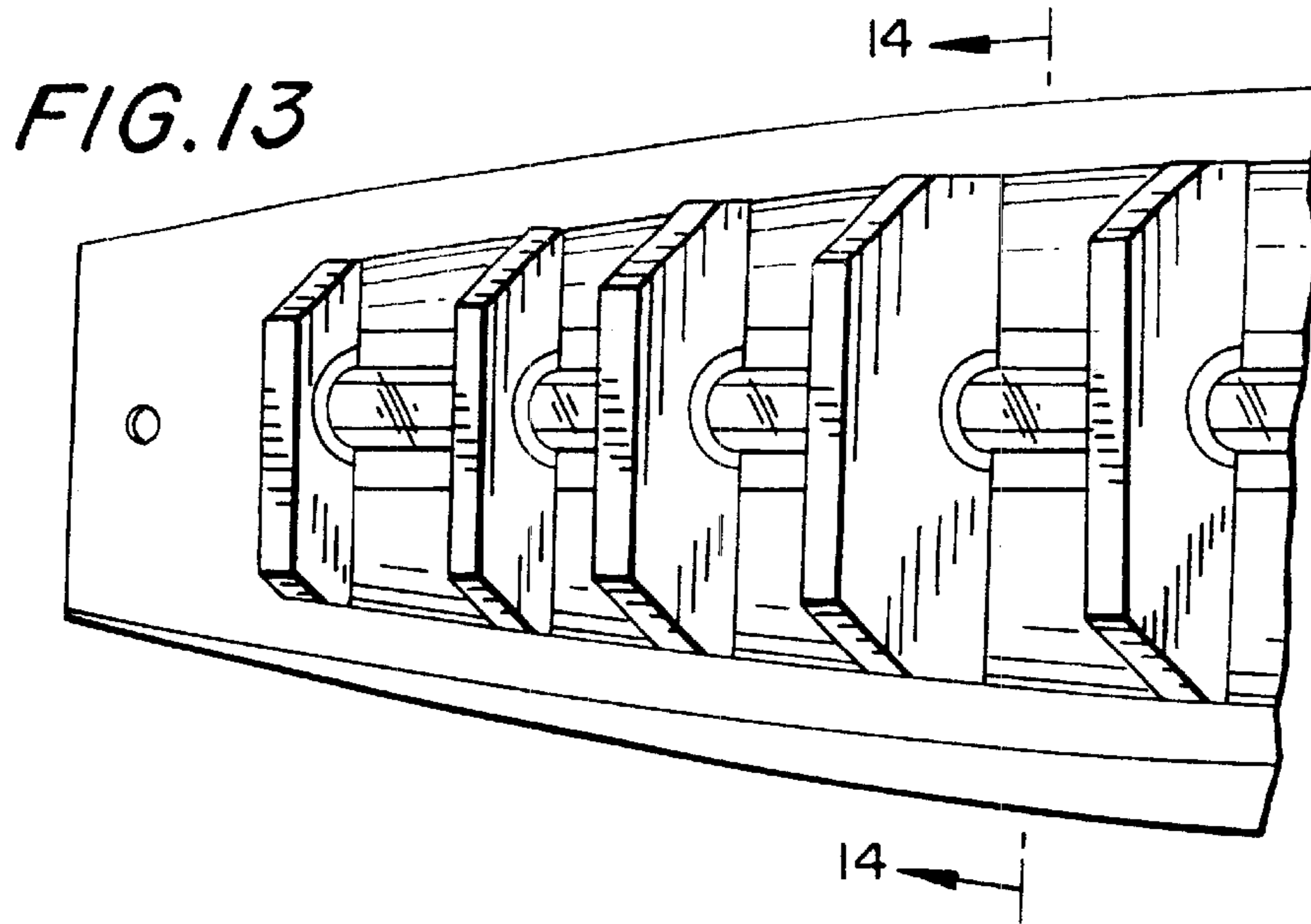

FIG. 17

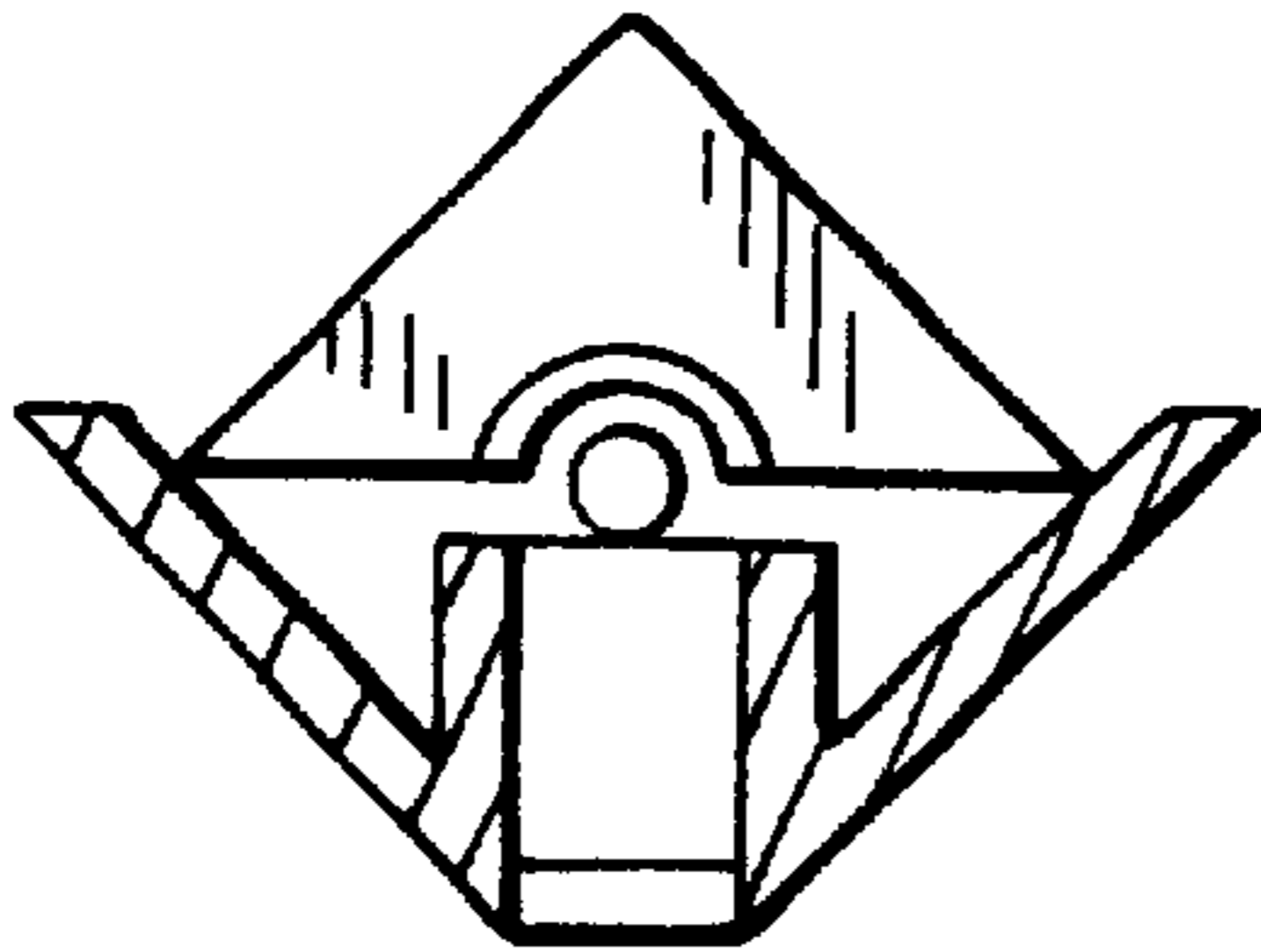

FIG. 18

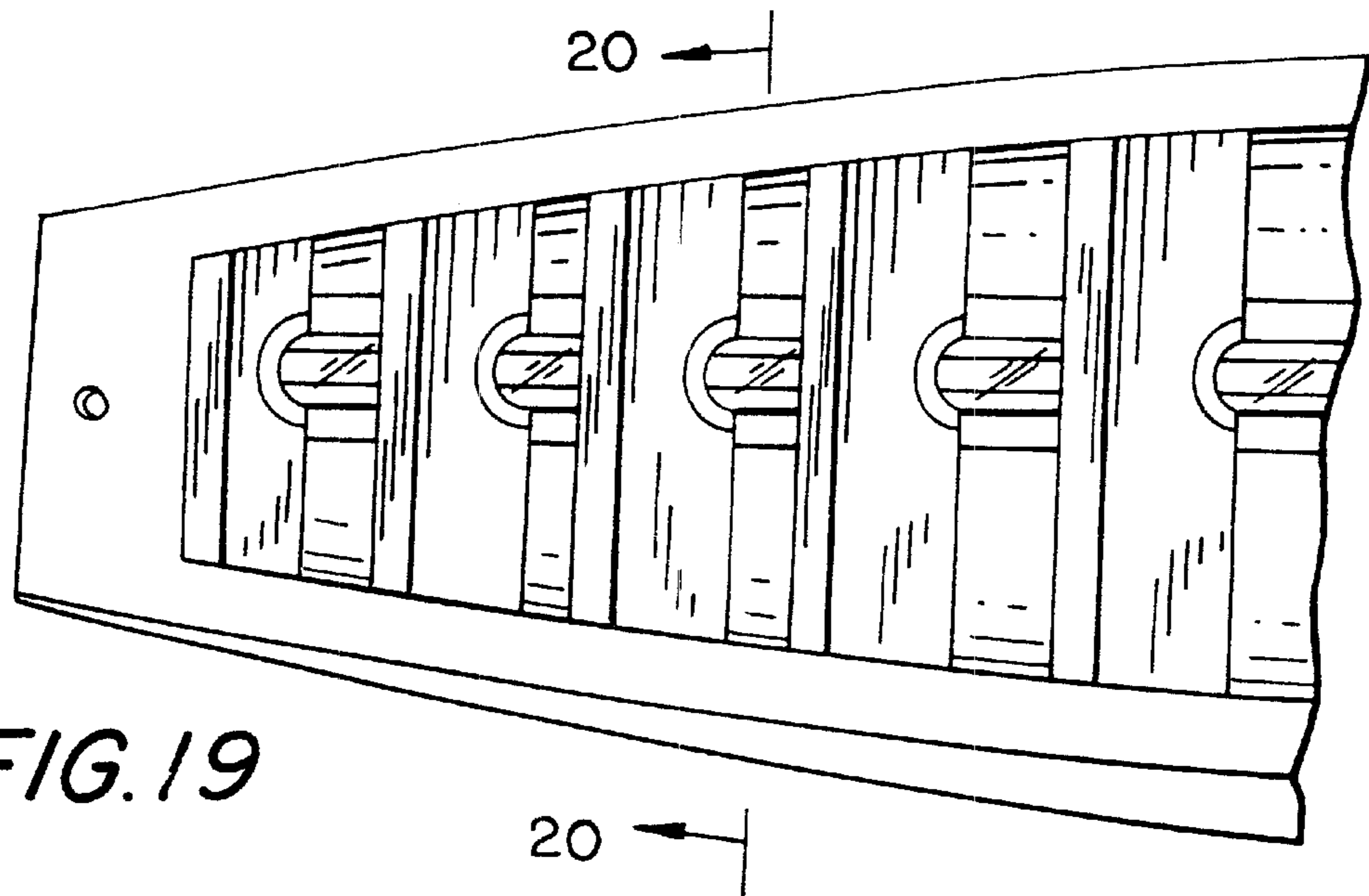
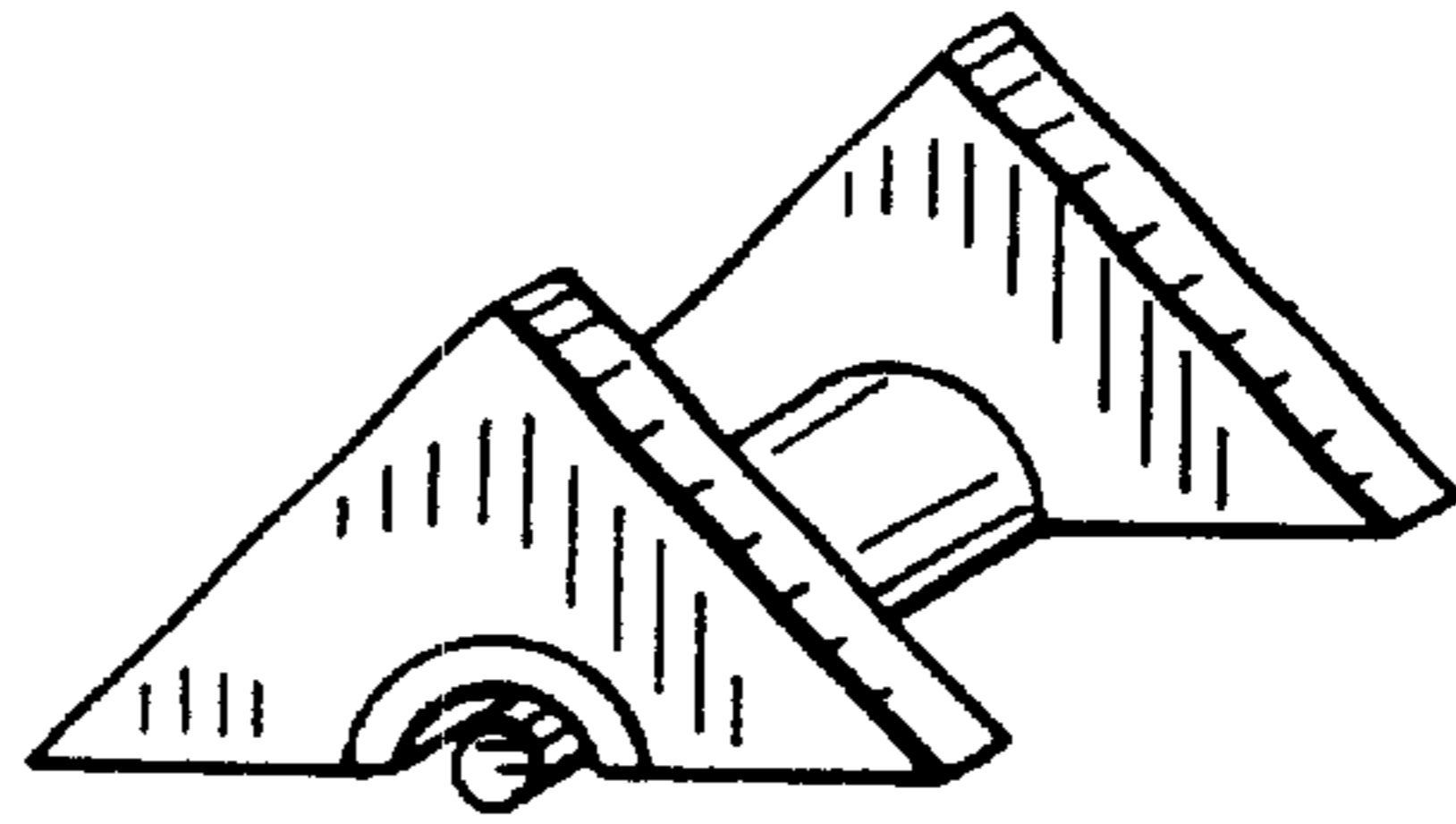

FIG. 19

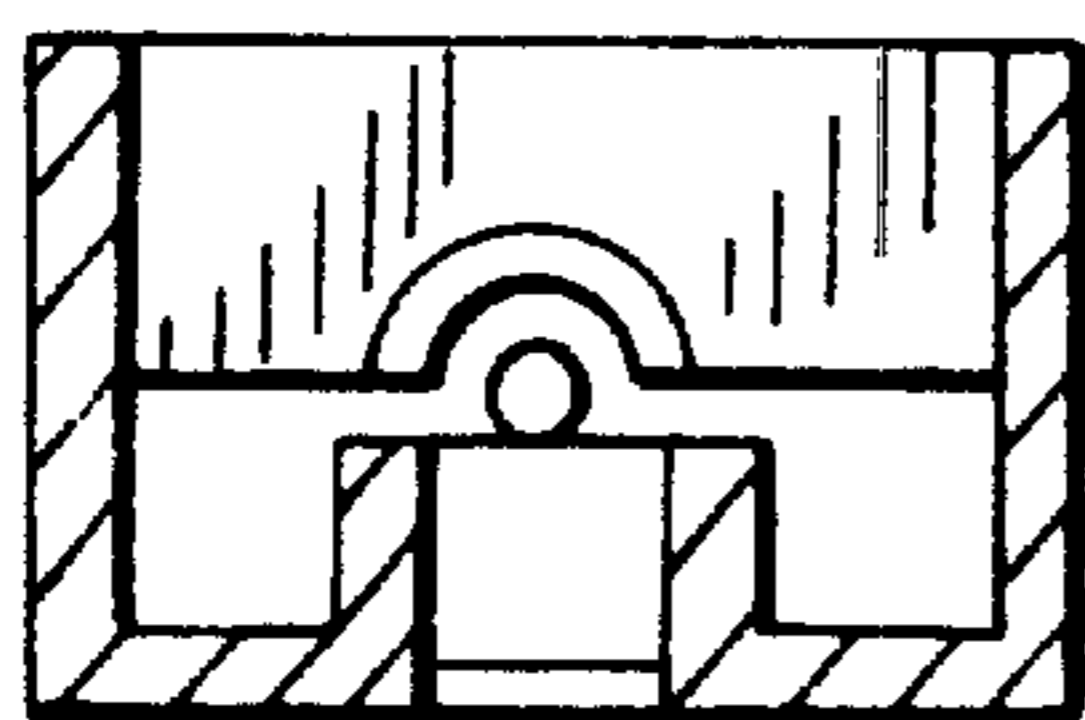

FIG. 20

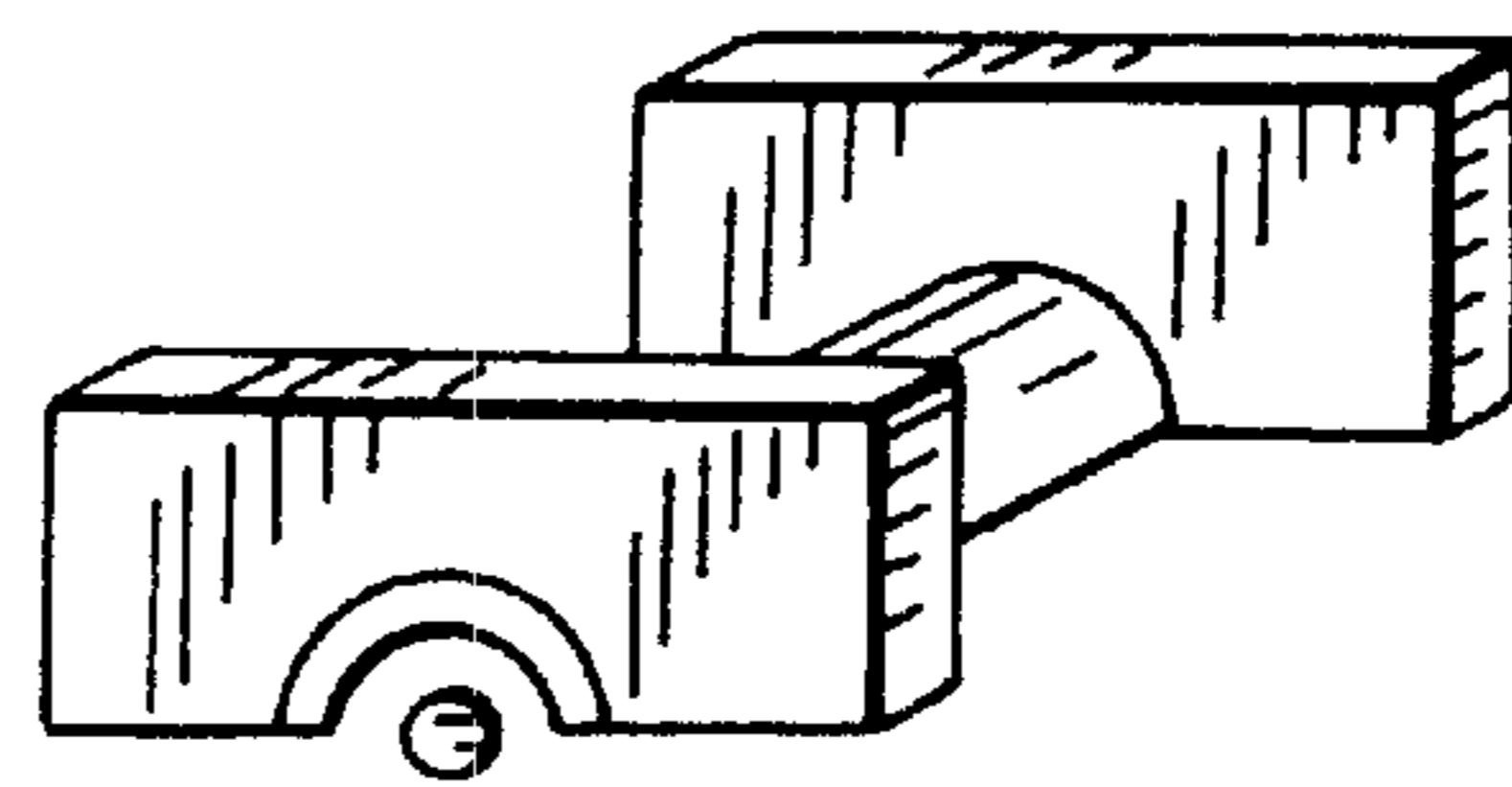

FIG. 21

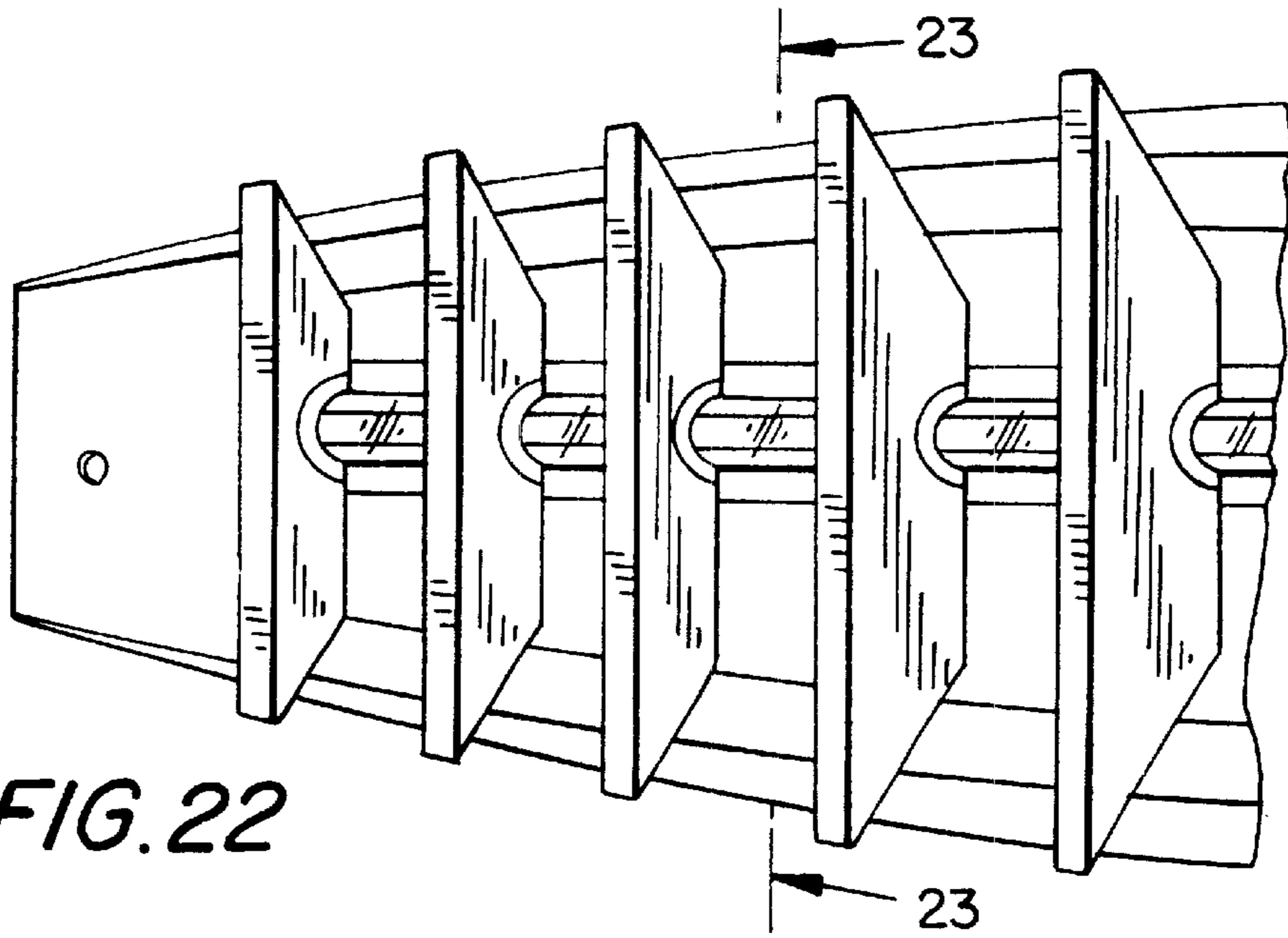

FIG. 22

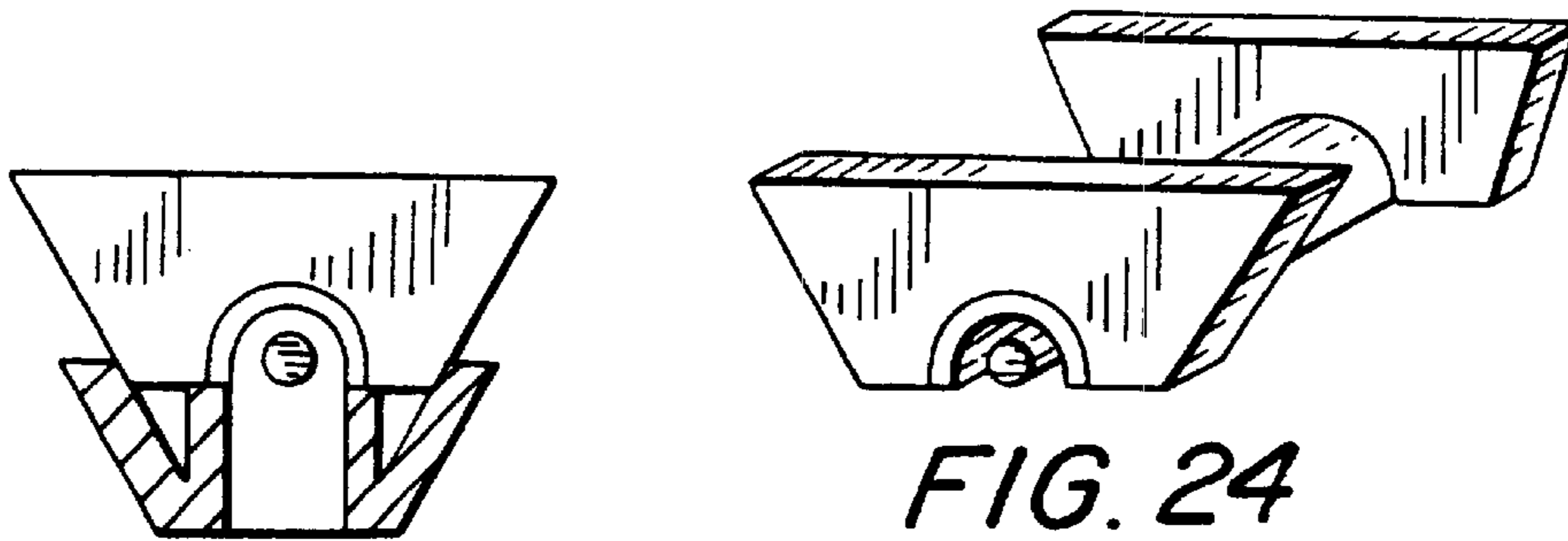

FIG. 23

FIG. 24

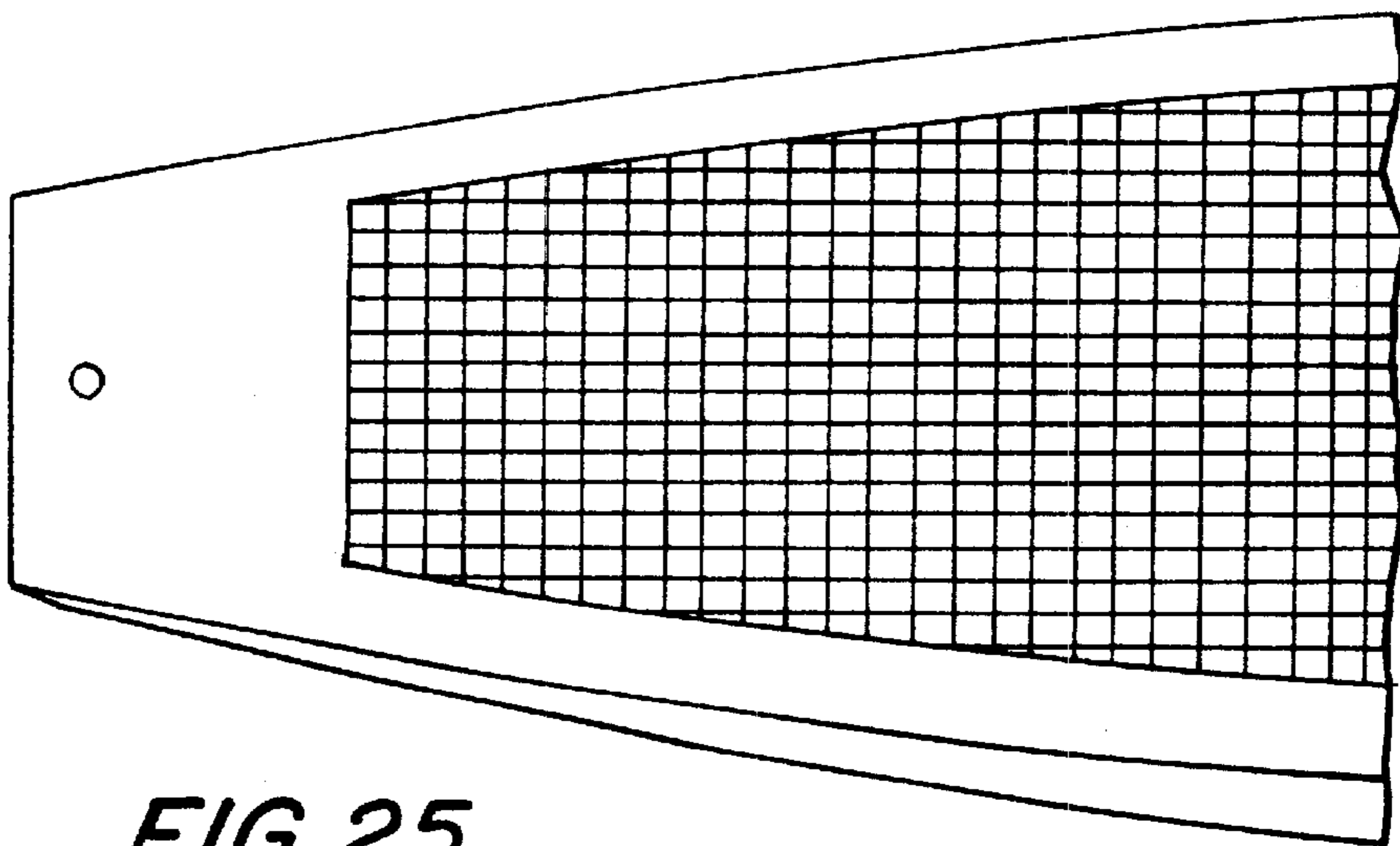

FIG. 25

FIG. 26

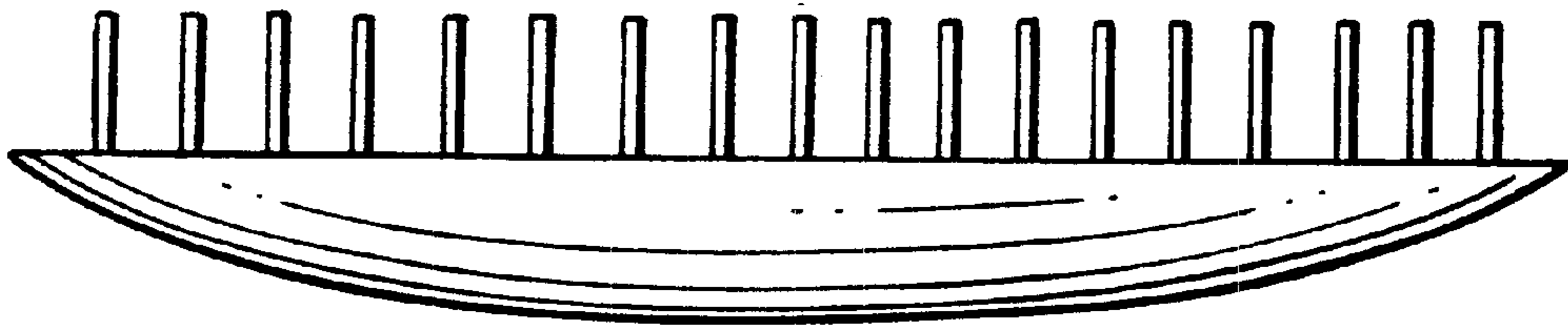

FIG. 27

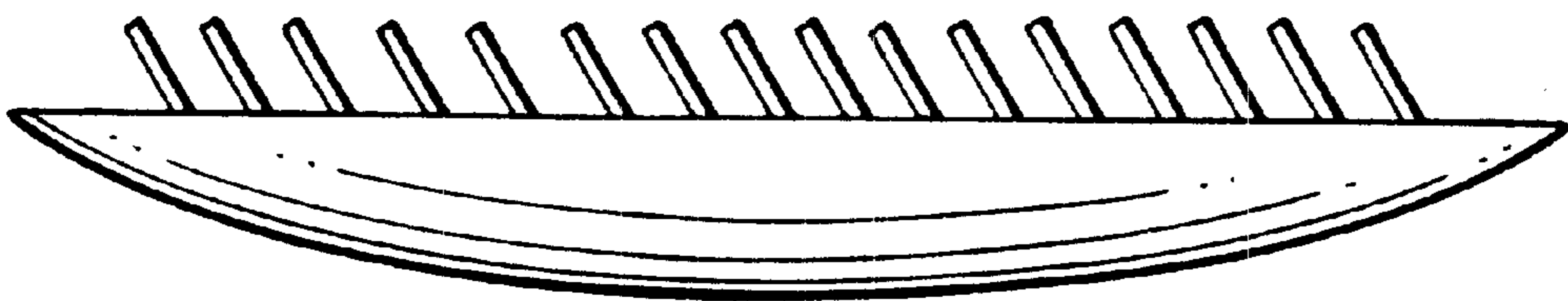

FIG. 34

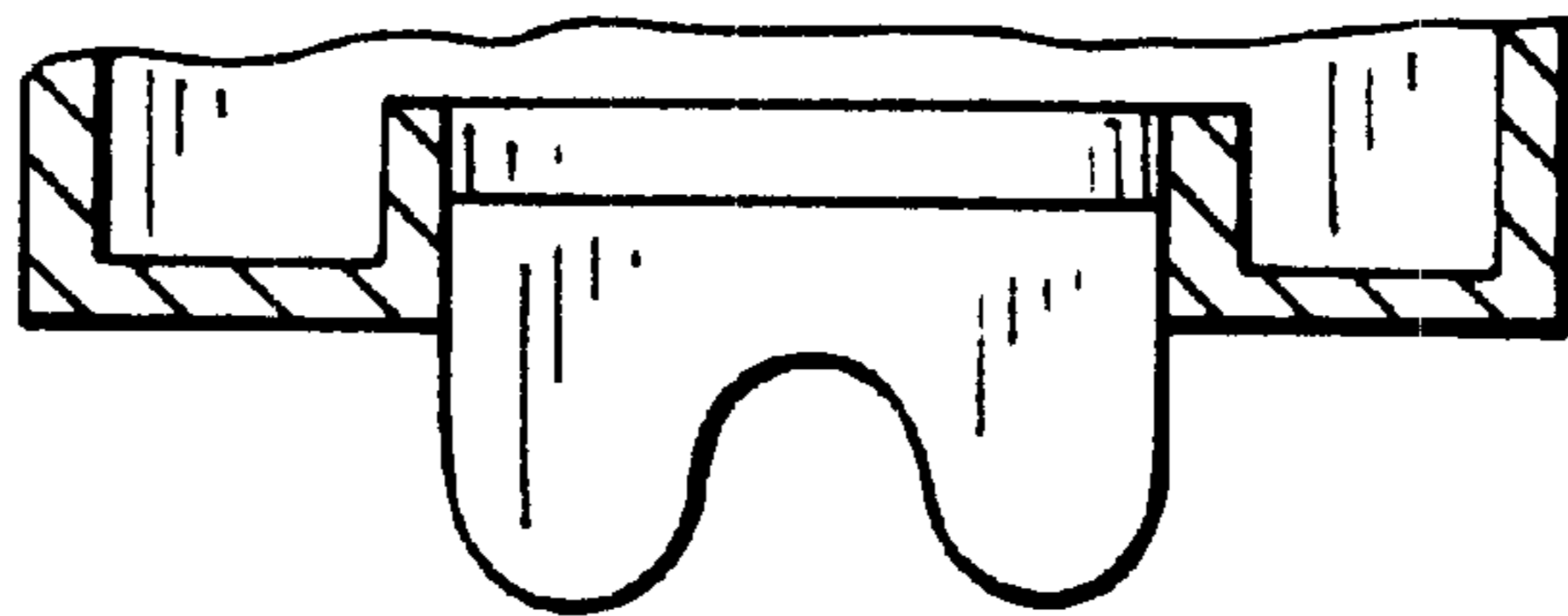

FIG. 35

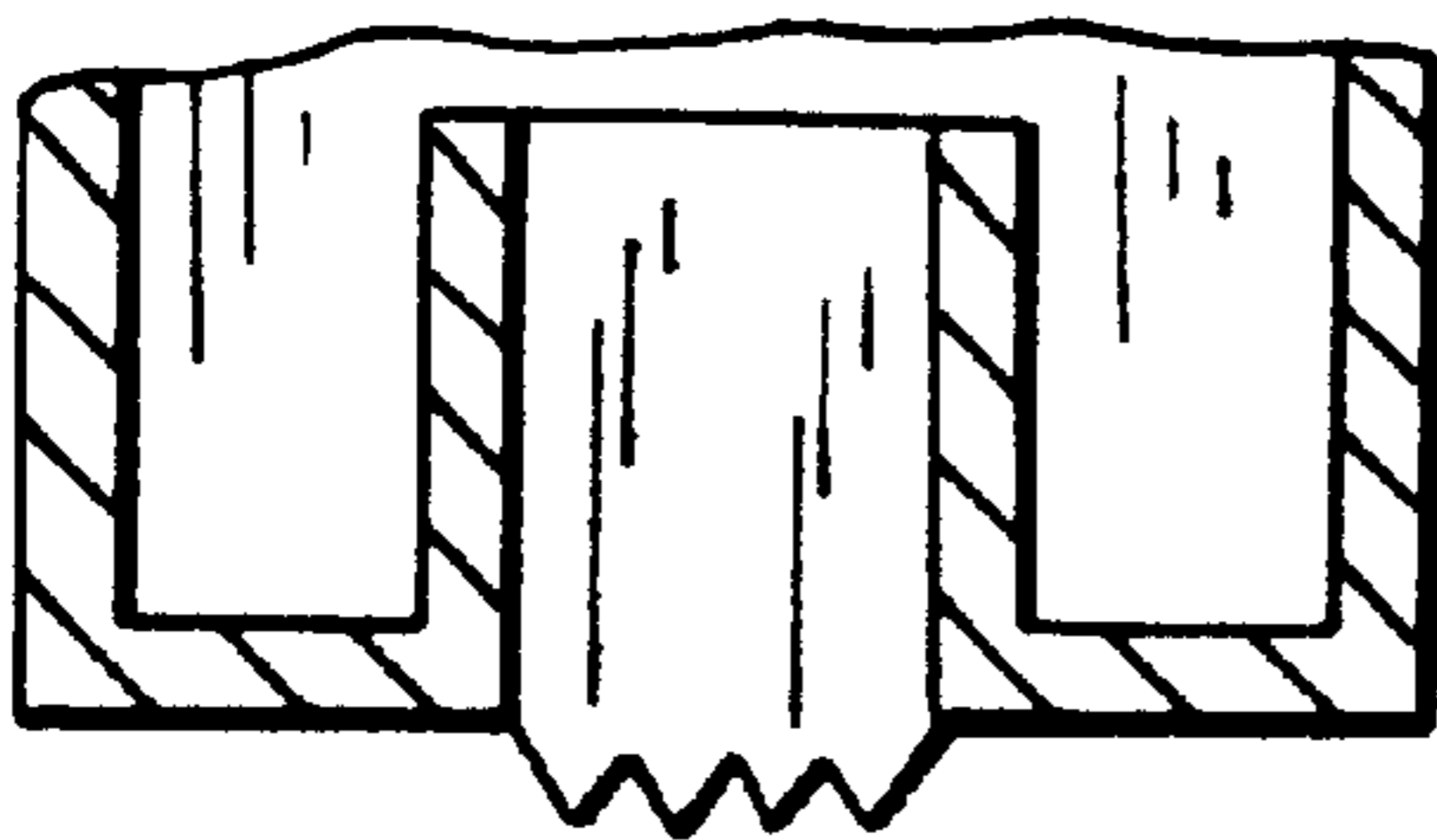
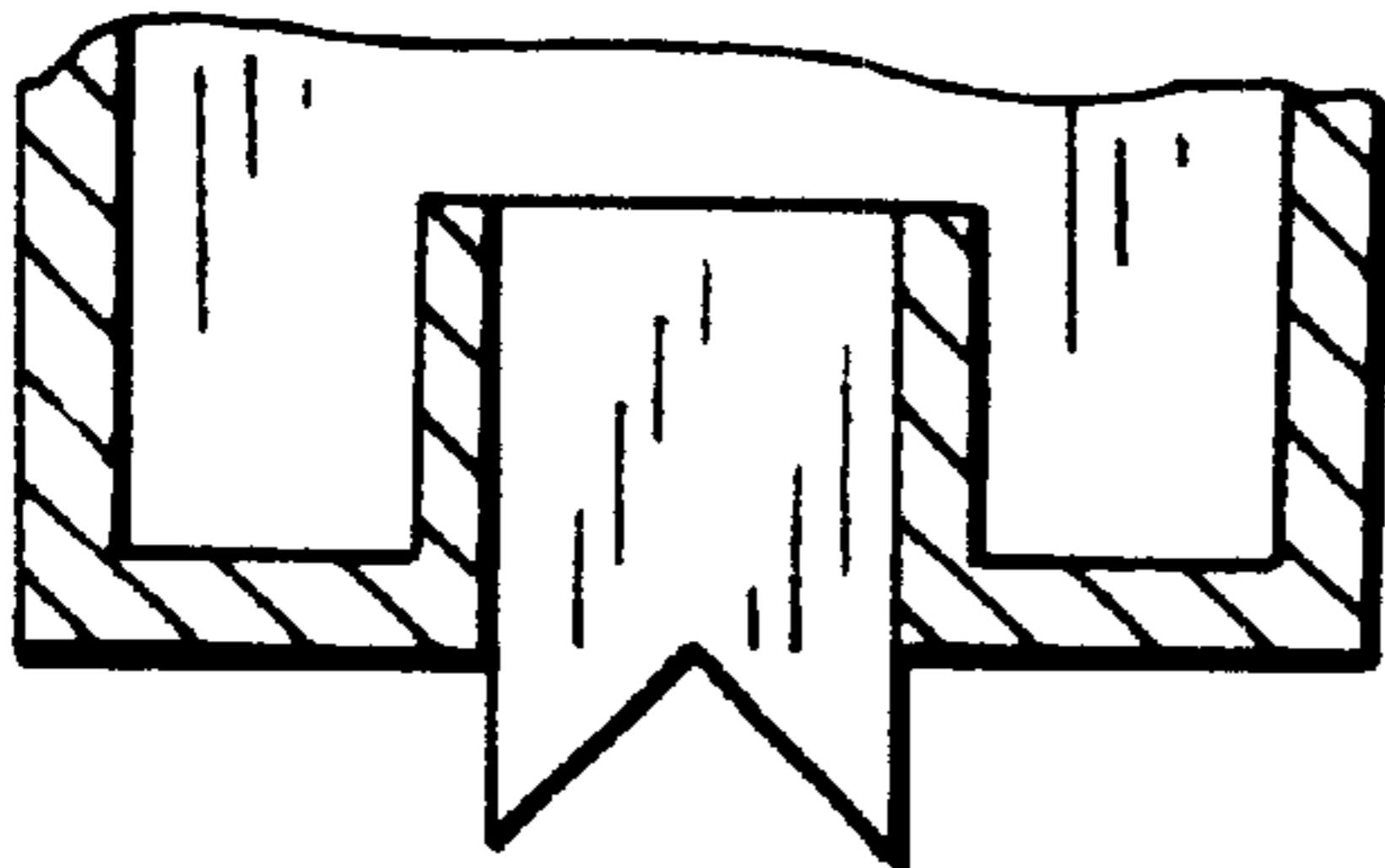

FIG. 37

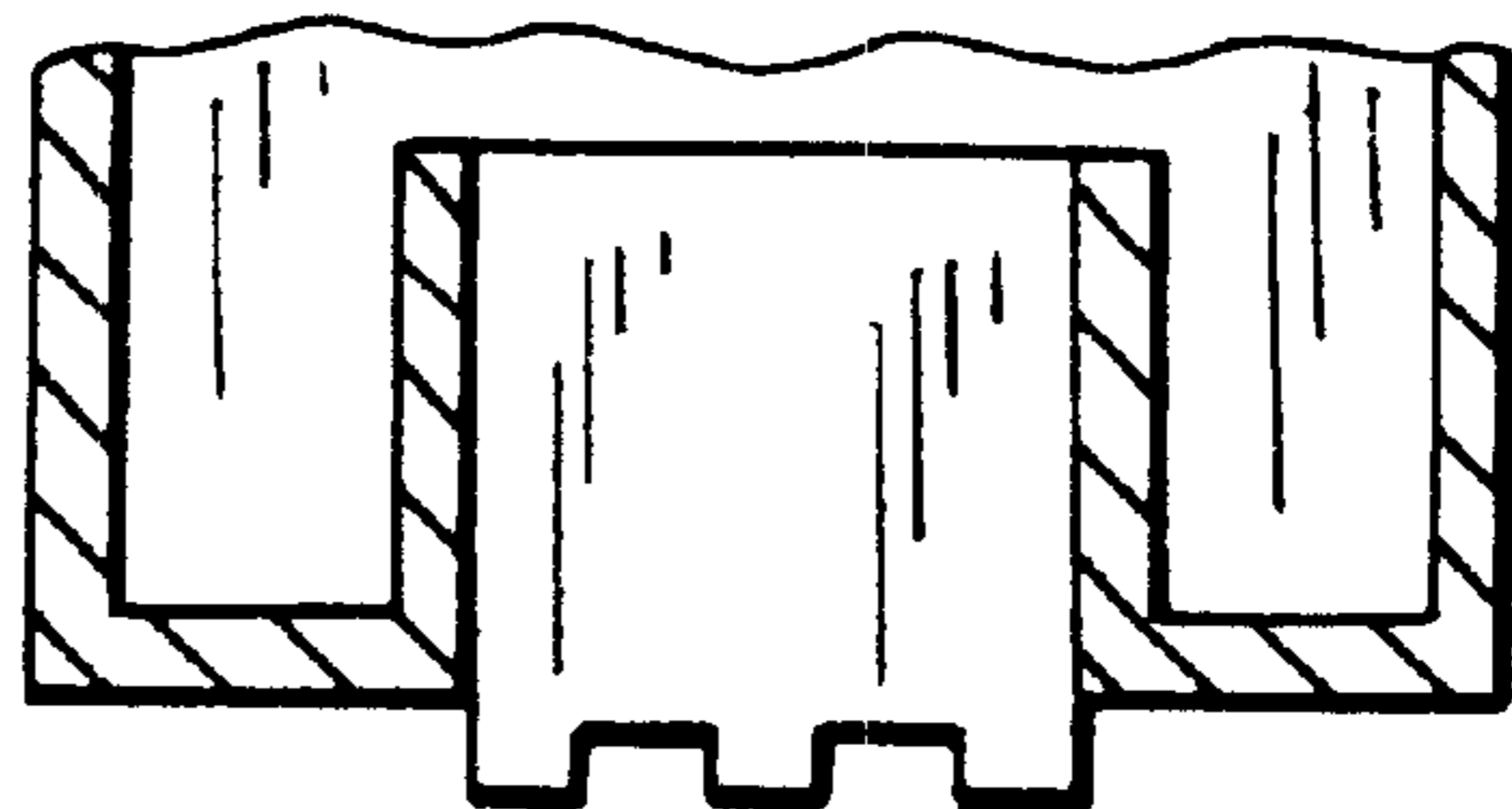

FIG. 36

FIG. 28

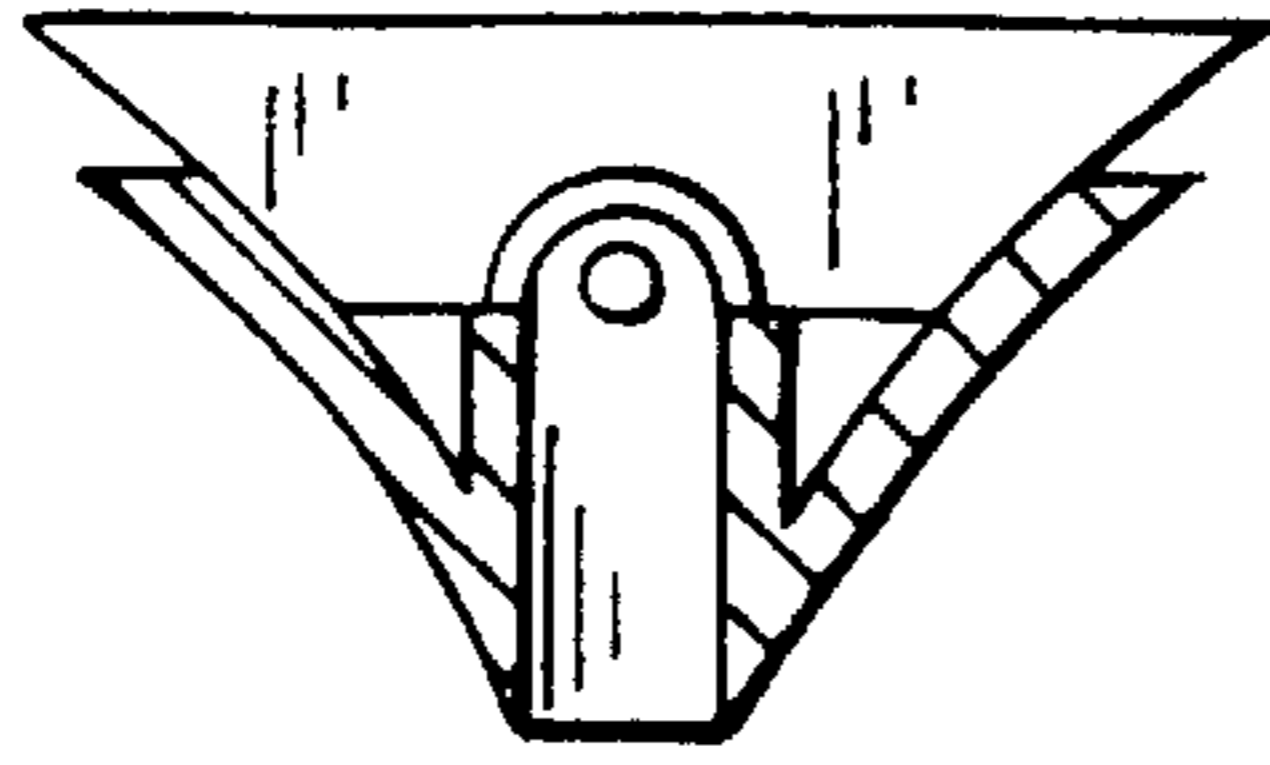

FIG. 29

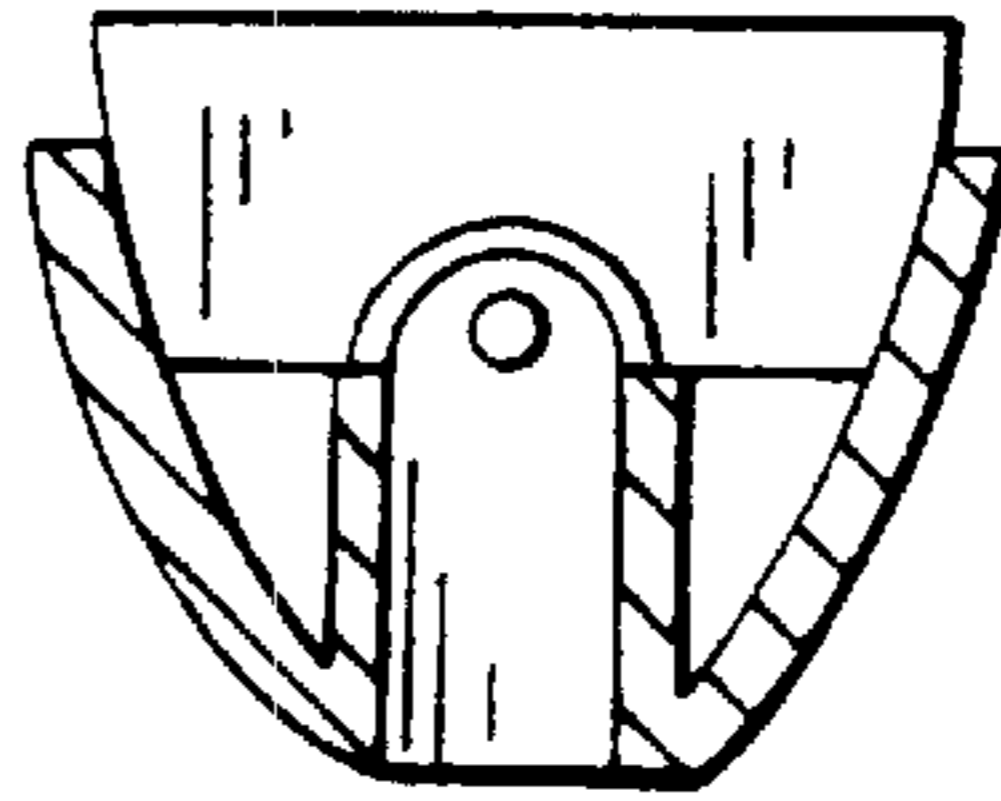

FIG. 31

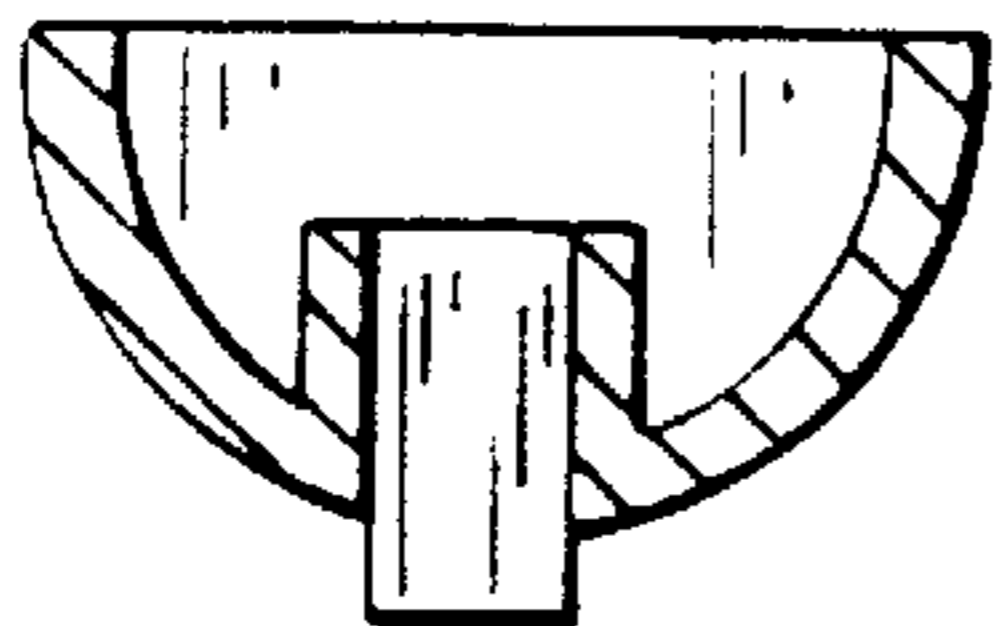

FIG. 33

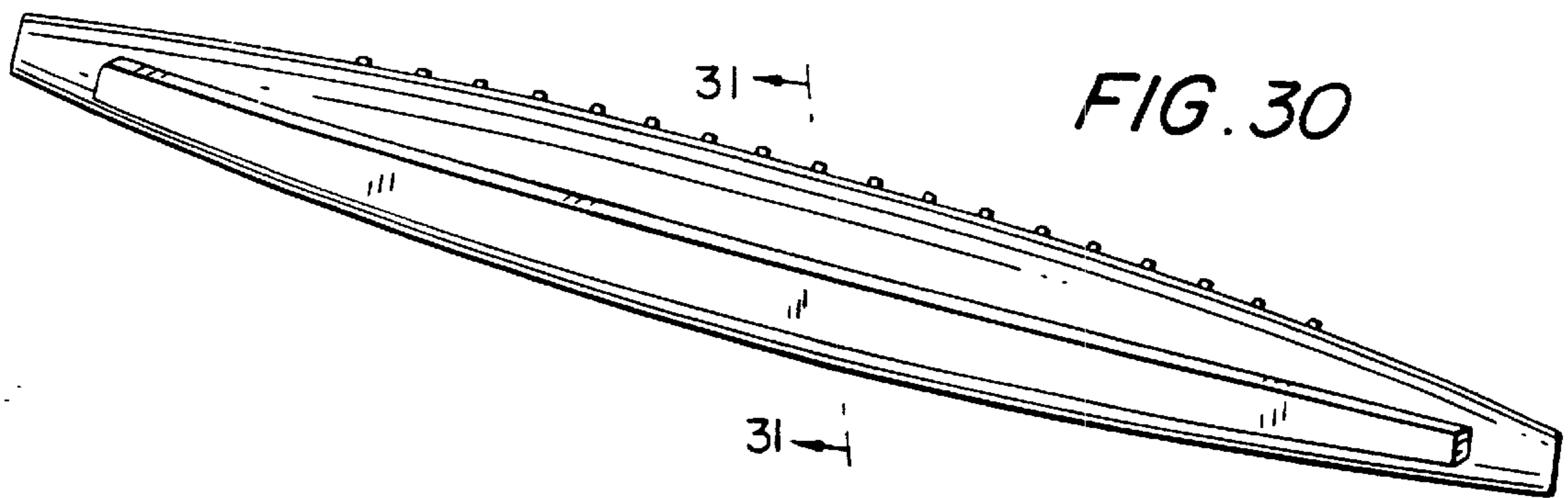
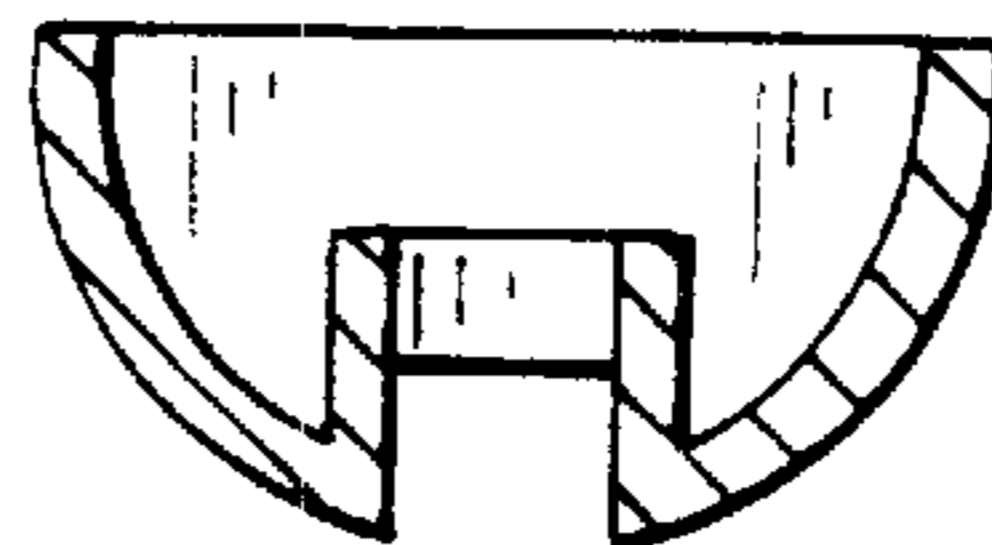

FIG. 30

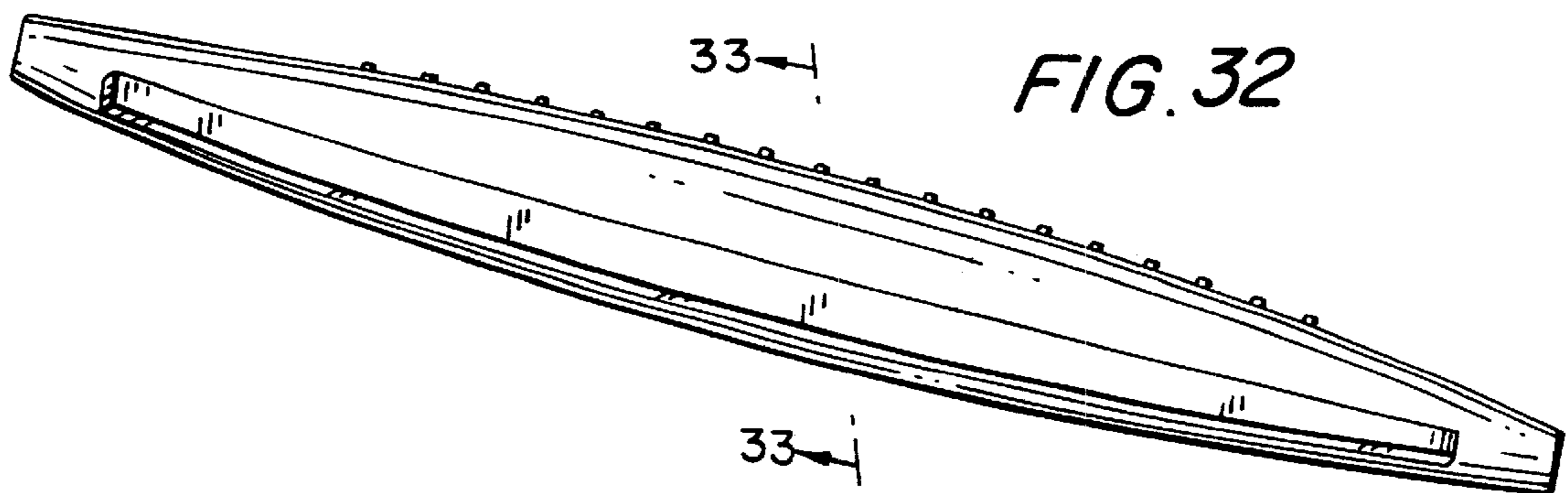

FIG. 32

FIG. 38

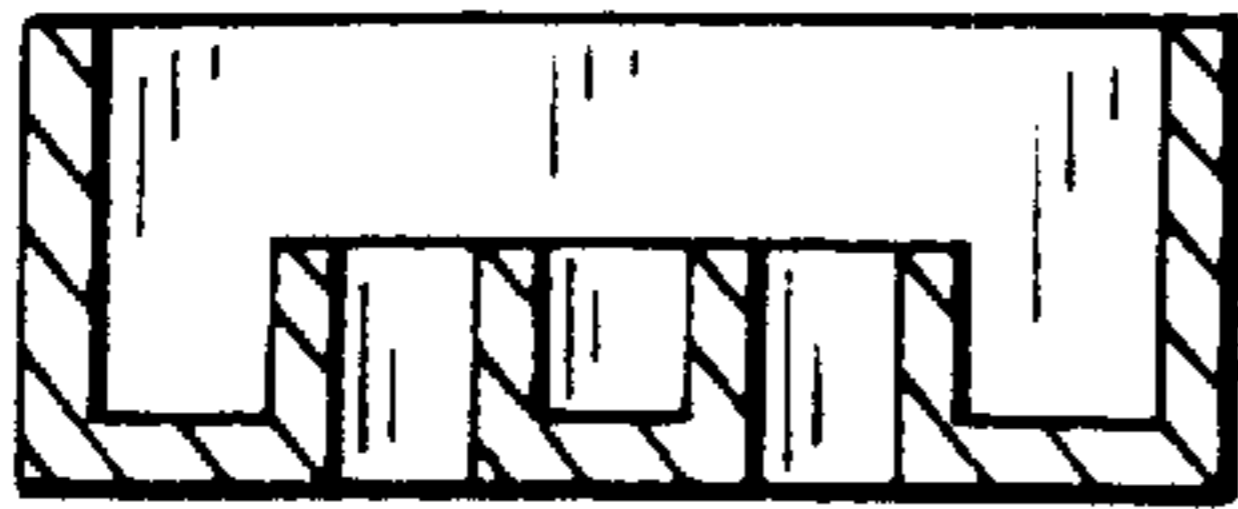

FIG. 39

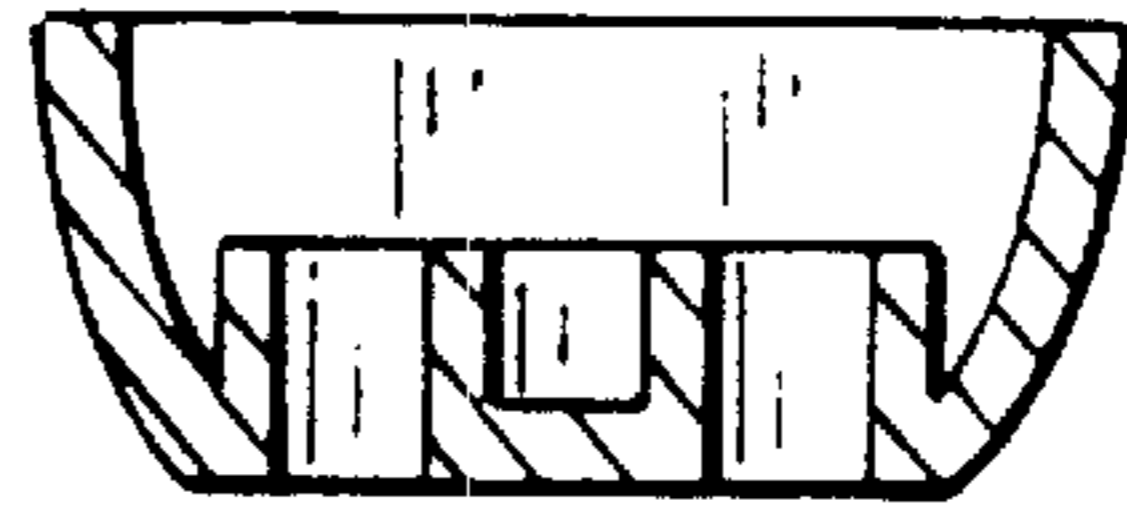

FIG. 40

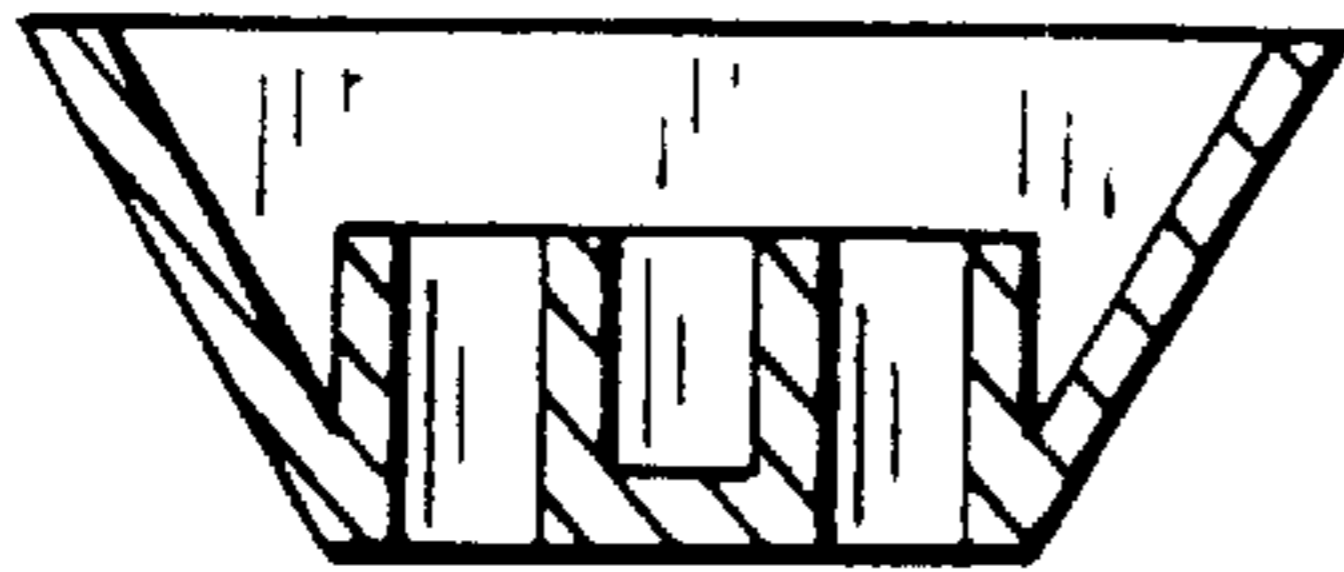

FIG. 44

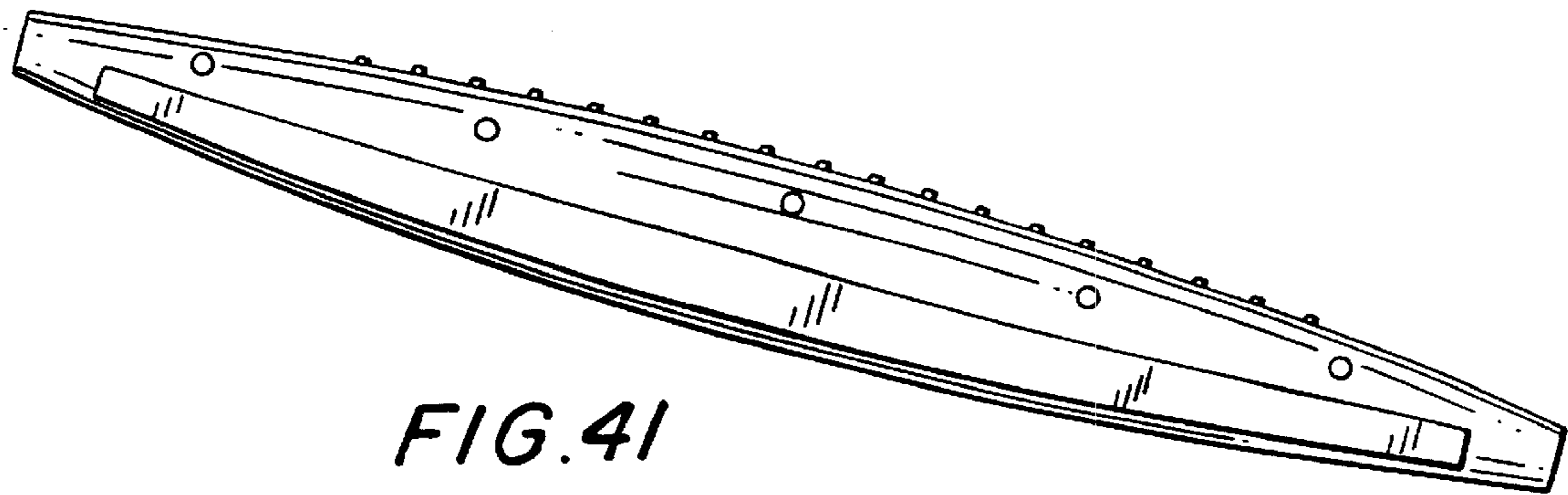
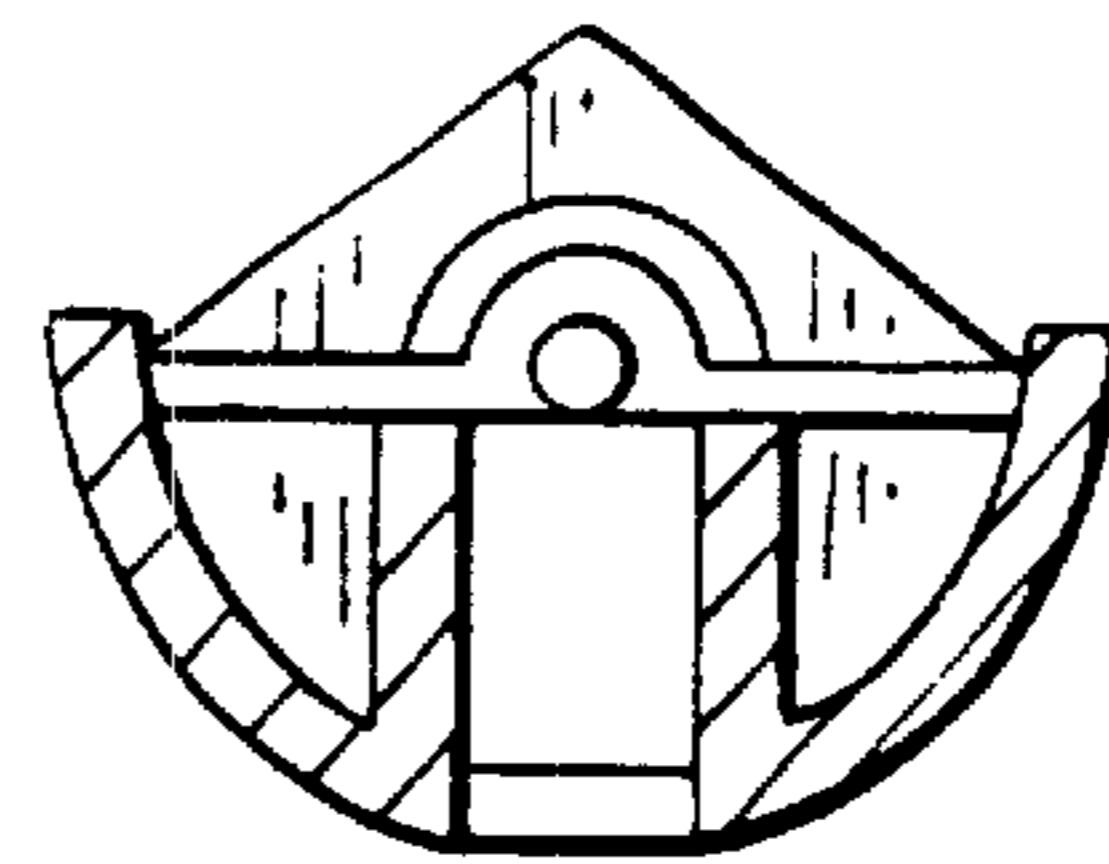

FIG. 41

