



US00D455197S

(12) **United States Design Patent**  
**Caplow**

(10) **Patent No.:** **US D455,197 S**

(45) **Date of Patent:** **\*\* Apr. 2, 2002**

(54) **HANDLE**

(75) **Inventor:** **Bradley R. Caplow**, Sherman Oaks,  
CA (US)

(73) **Assignee:** **Kallista, Inc.**, Kohler, WI (US)

(\*\*) **Term:** **14 Years**

(21) **Appl. No.:** **29/123,507**

(22) **Filed:** **May 18, 2000**

**Related U.S. Application Data**

(62) Division of application No. 29/103,073, filed on Apr. 7,  
1999, now Pat. No. Des. 438,601.

(51) **LOC (7) Cl.** ..... **23-01**

(52) **U.S. Cl.** ..... **D23/250; D23/254**

(58) **Field of Search** ..... D23/238-243,  
D23/249-254; D8/300-312, 350-353, DIG. 2;  
4/675-678; 16/110 R; 137/801

(56) **References Cited**

**U.S. PATENT DOCUMENTS**

D76,904 S	*	11/1928	Smith	.....	D23/254
D76,995 S	*	11/1928	Fraser	.....	D23/254
D83,924 S	*	4/1931	Sakier	.....	D23/254
D318,714 S		7/1991	Spangler	.....	D23/250
D321,630 S		11/1991	Hollinger	.....	D7/679
D325,958 S		5/1992	Stairs, Jr. et al.	.....	D23/250
D327,531 S		6/1992	Ko	.....	D23/250
D372,299 S		7/1996	Fabian	.....	D23/250

D404,802 S		1/1999	Delker	.....	D23/252
D405,508 S		2/1999	Doughty et al.	.....	D23/252
D405,509 S	*	2/1999	Doughty et al.	.....	D23/252

**OTHER PUBLICATIONS**

1997 Kohler catalog ad, p. 2.10, showing "Finial" cross  
lever handles.

1989 Kallista ad showing a cross lever handle.

1987 Auburn ad showing a #2001 escutcheon.

\* cited by examiner

*Primary Examiner*—Louis S. Zarfes

*Assistant Examiner*—Gregory Andoll

(74) *Attorney, Agent, or Firm*—Quarles & Brady LLP

(57) **CLAIM**

The ornamental design for a handle, as shown and described.

**DESCRIPTION**

In a preferred embodiment, the nature of this product is as  
a plumbing handle primarily useful for controlling a rotat-  
able valve stem.

FIG. 1 is a left, top, front perspective view of a handle  
embodying my new design;

FIG. 2 is a front elevational view thereof, the right side, left  
side, and rear elevational views being identical to the front  
elevational view shown; and,

FIG. 3 is a top plan view thereof.

The broken line representation of a mounting environment  
in FIG. 1 is for the purpose of illustration only, and forms no  
part of the claimed design.

**1 Claim, 1 Drawing Sheet**

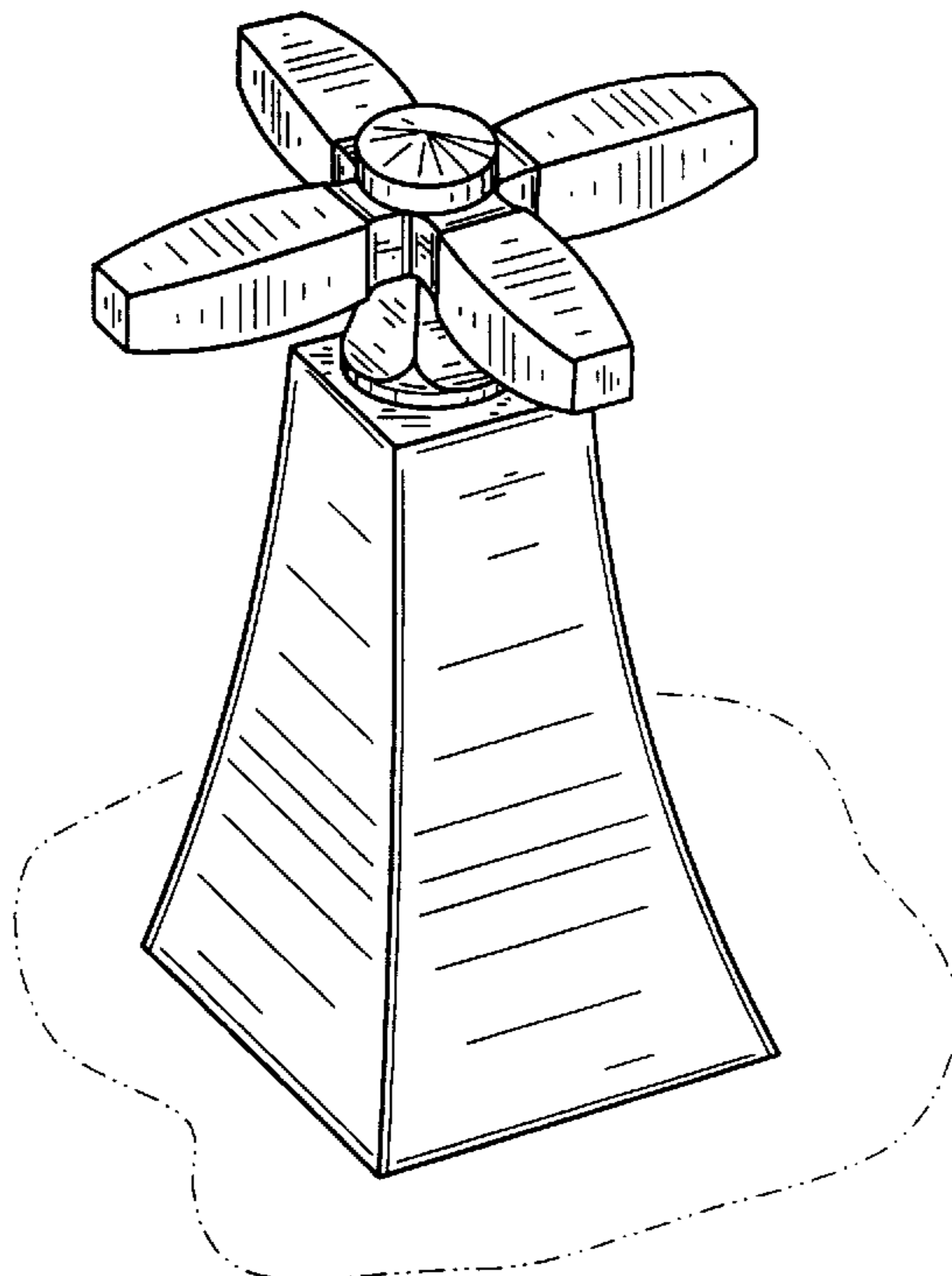

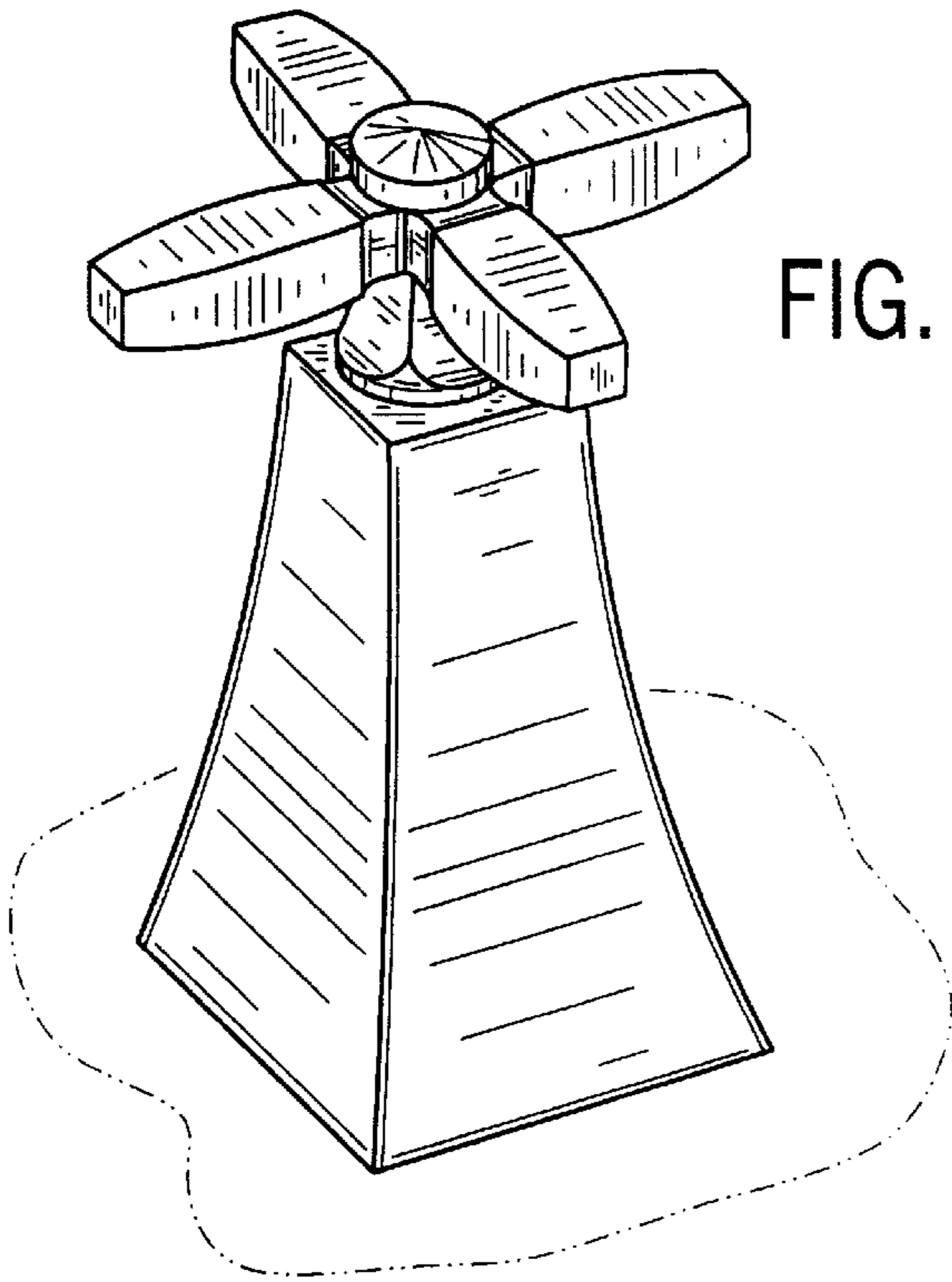

FIG. 1

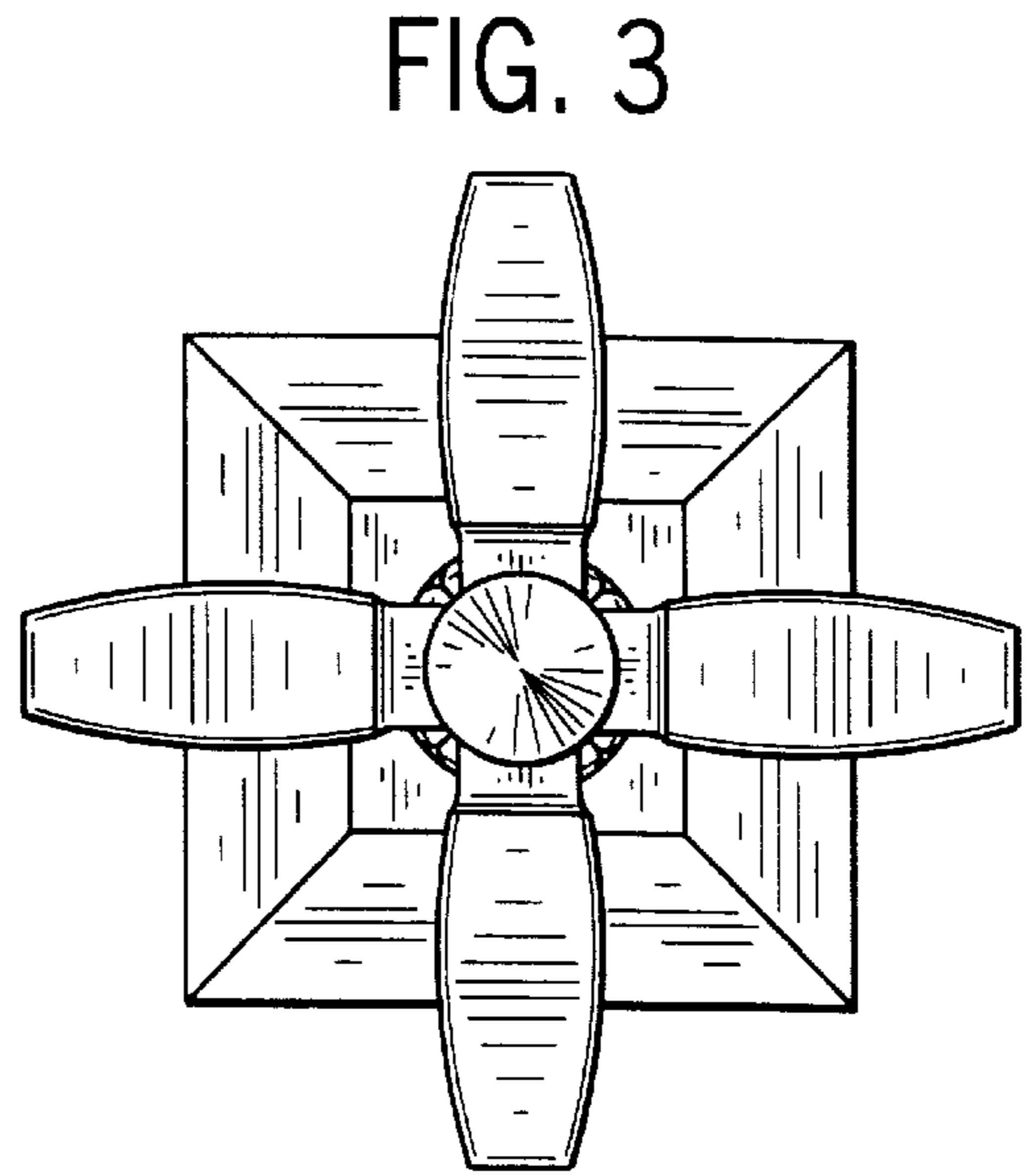

FIG. 3

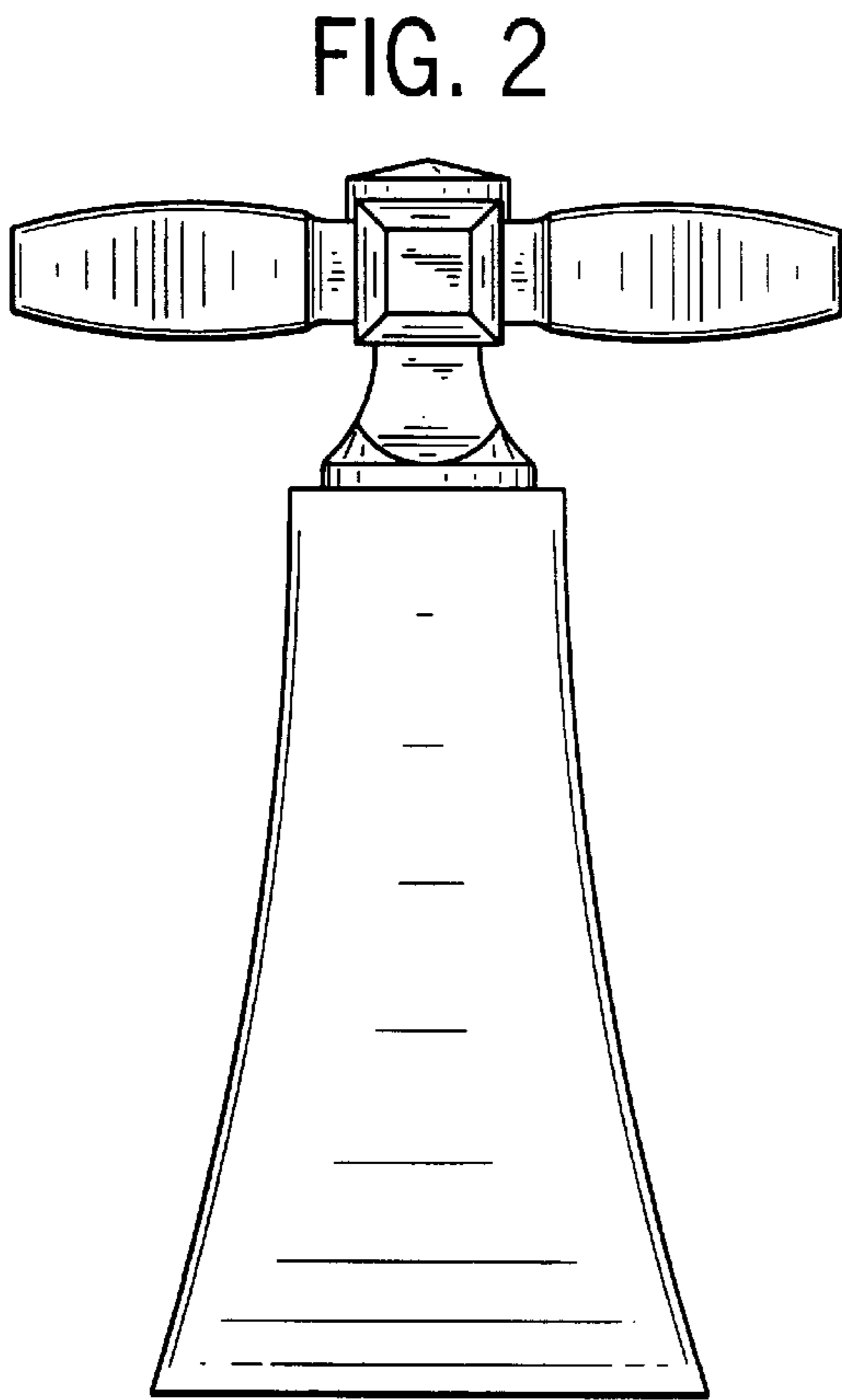

FIG. 2