



US00D454819S

(12) **United States Design Patent**
Nakazawa

(10) **Patent No.:** **US D454,819 S**

(45) **Date of Patent:** **** Mar. 26, 2002**

(54) **MOTORCYCLE BRAKE HOUSING**

(75) Inventor: **Tetsuya Nakazawa**, Rancho Palos Verdes, CA (US)

(73) Assignee: **Honda Giken Kogyo Kabushiki Kaisha**, Tokyo (JP)

(**) Term: **14 Years**

(21) Appl. No.: **29/144,417**

(22) Filed: **Jul. 3, 2001**

(51) **LOC (7) Cl.** **12-16**

(52) **U.S. Cl.** **D12/179**

(58) **Field of Search** D12/179, 180, D12/110, 114, 126; 180/219; 74/488, 489, 502.2, 551.8, 551.9; 188/24.11, 24.16, 344

(56) **References Cited**

U.S. PATENT DOCUMENTS

D376,340 S * 12/1996 Davidson et al. D12/180

OTHER PUBLICATIONS

Drag Specialties 1995 catalog, master cylinder assemblies on p. 406.*

* cited by examiner

Primary Examiner—Alan P. Douglas

Assistant Examiner—Linda Brooks

(74) *Attorney, Agent, or Firm*—Banner & Witcoff, Ltd.

(57) **CLAIM**

The ornamental design for a motorcycle brake housing, as shown and described.

DESCRIPTION

FIG. 1 is a frontal perspective view of a motorcycle brake housing showing my new design;

FIG. 2 is a rear perspective view thereof;

FIG. 3 is an outer end elevational view thereof;

FIG. 4 is a rear elevational view thereof; and,

FIG. 5 is a top plan view thereof.

The broken line showing of the circular elements within the shaded area, and the broken line showing of the handle bar and brake are for illustrative purposes only and form no part of the claimed design.

1 Claim, 2 Drawing Sheets

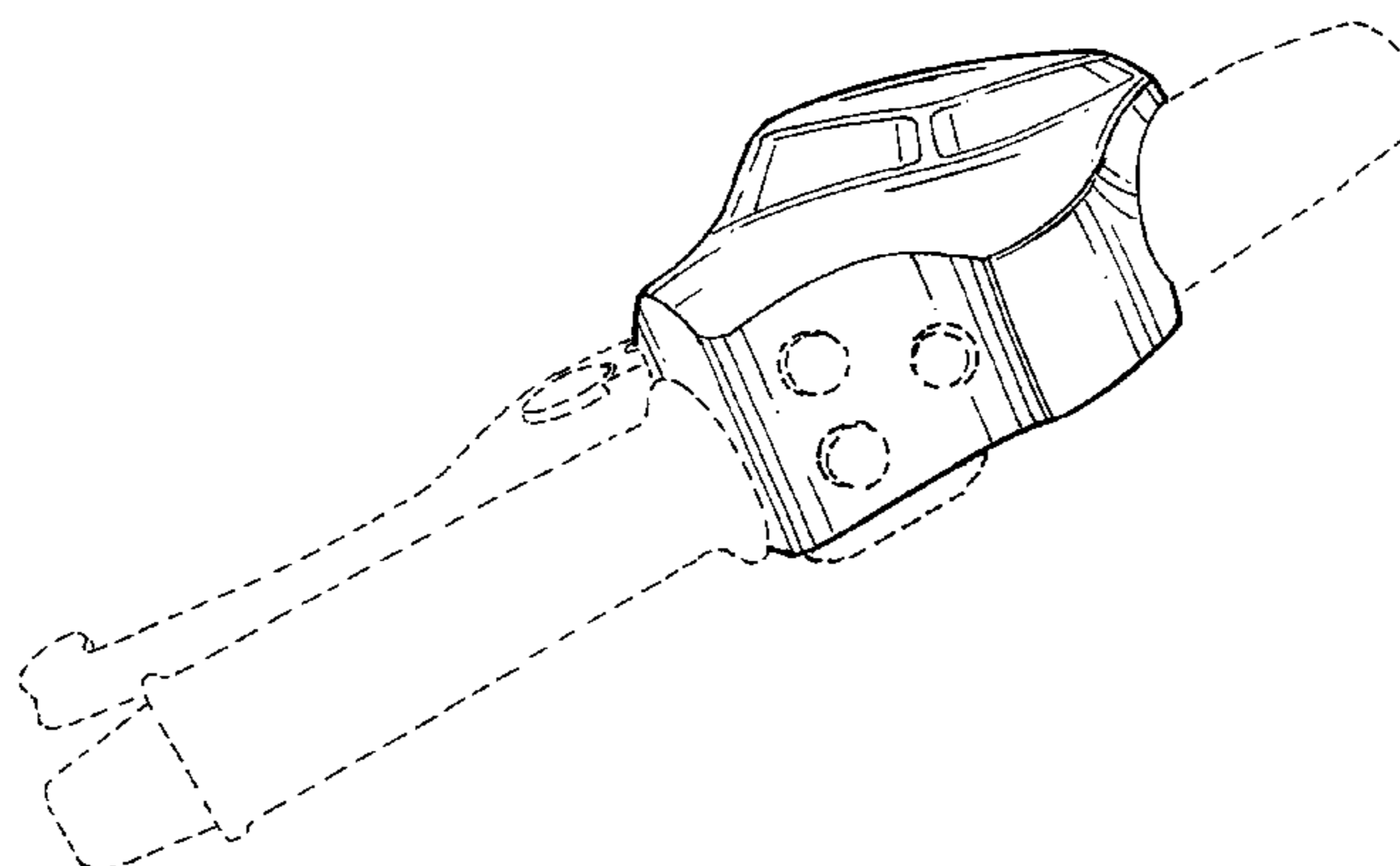
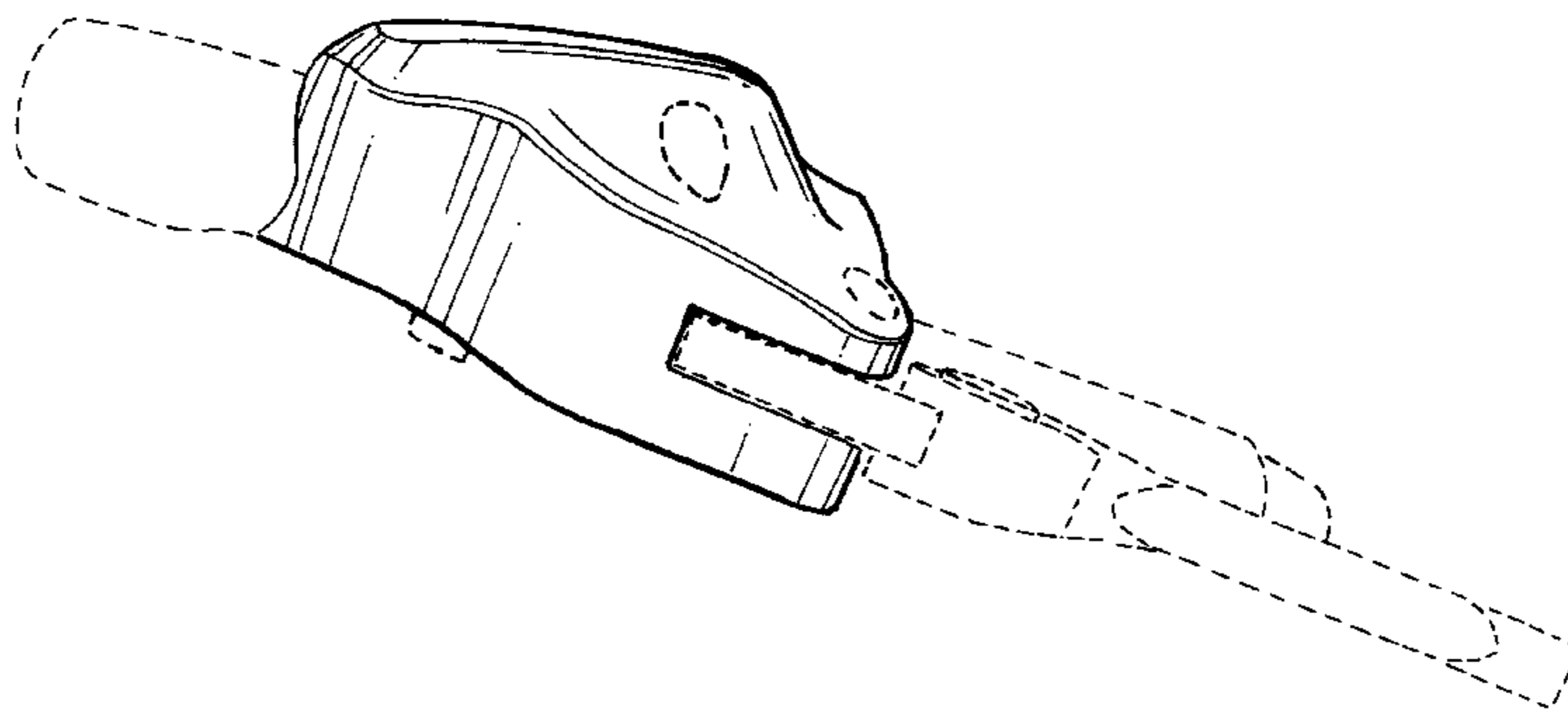

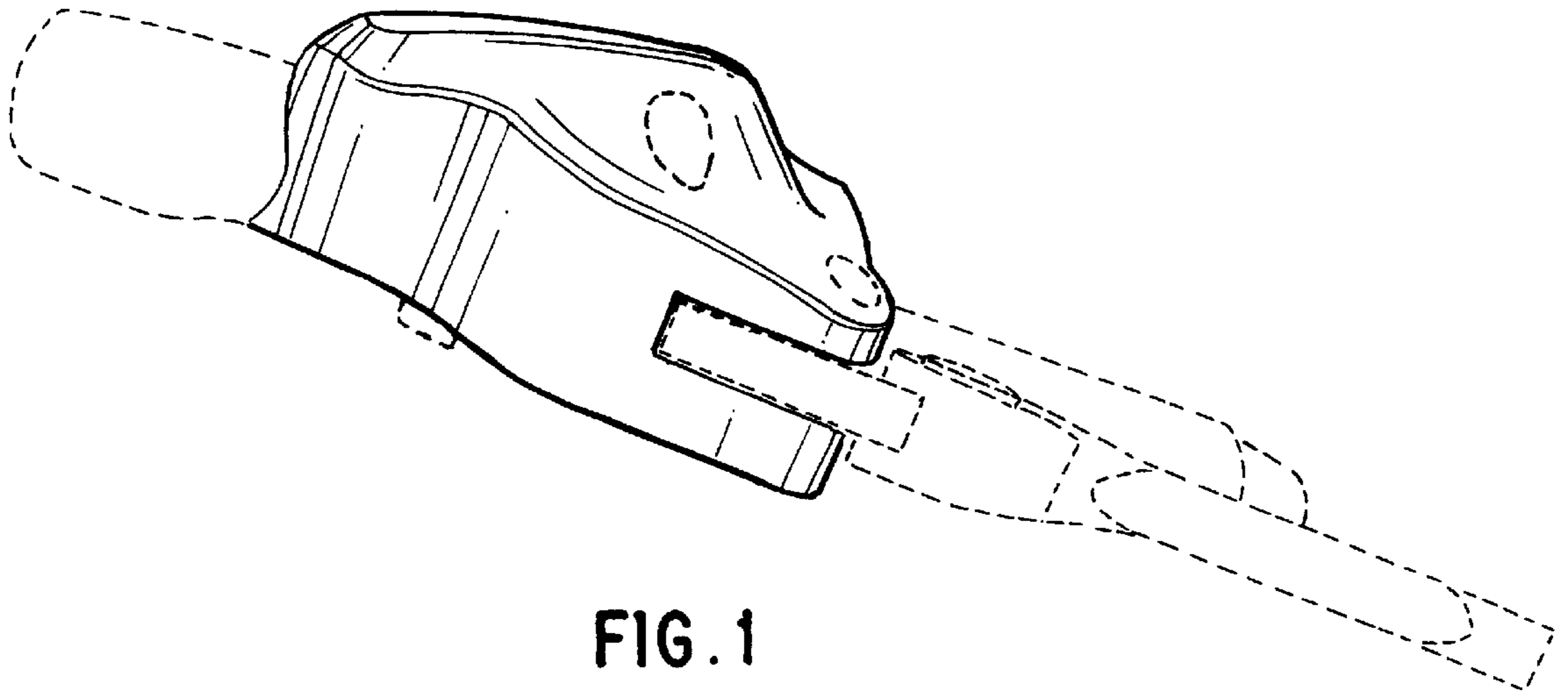

FIG. 1

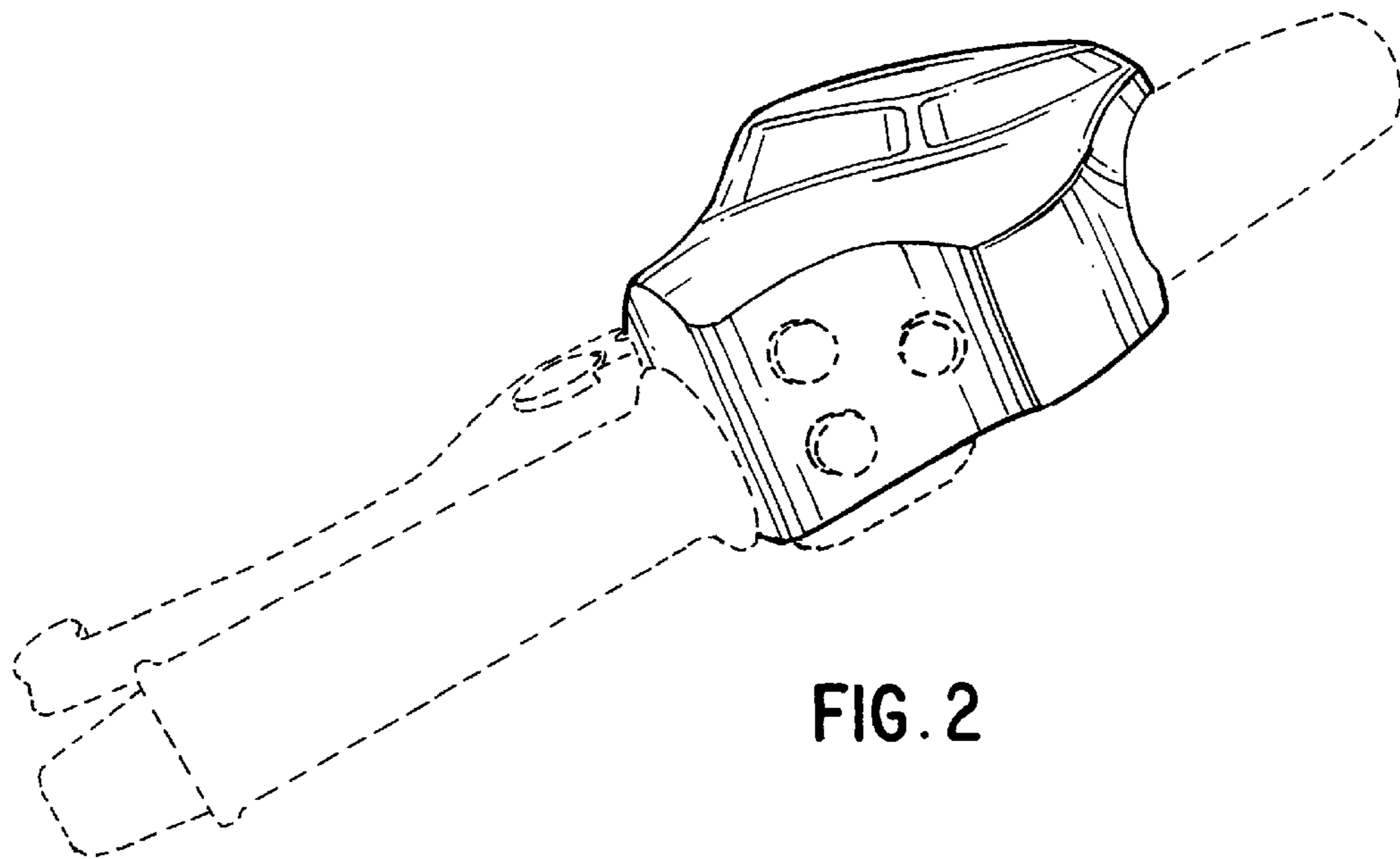

FIG. 2

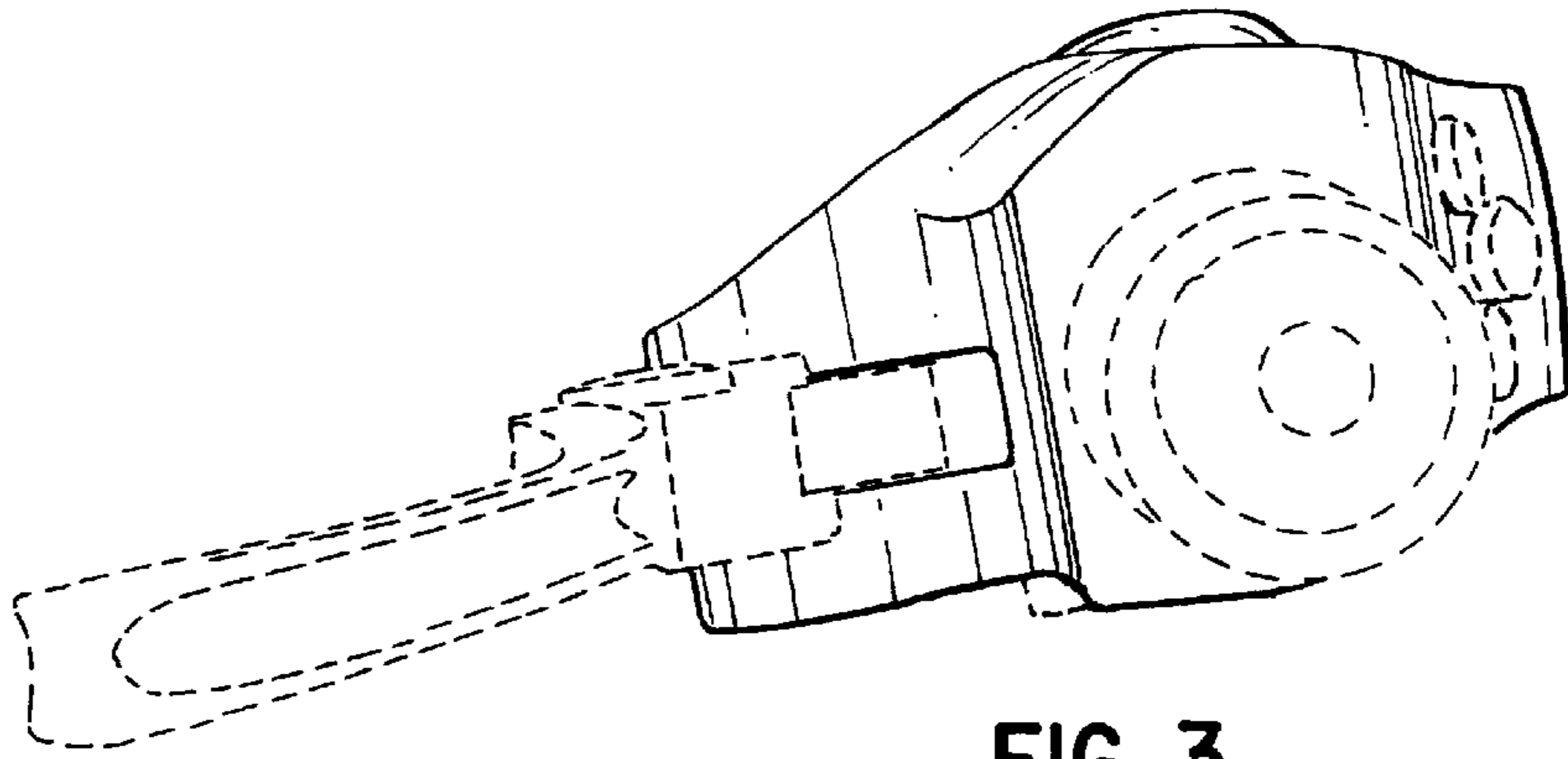

FIG. 3

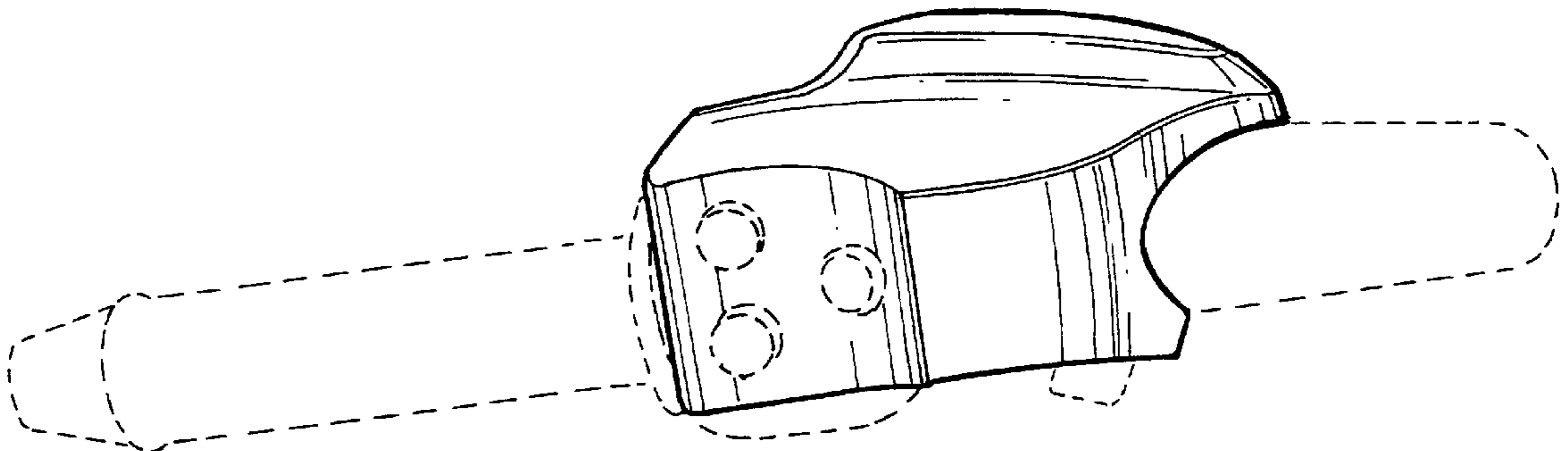

FIG. 4

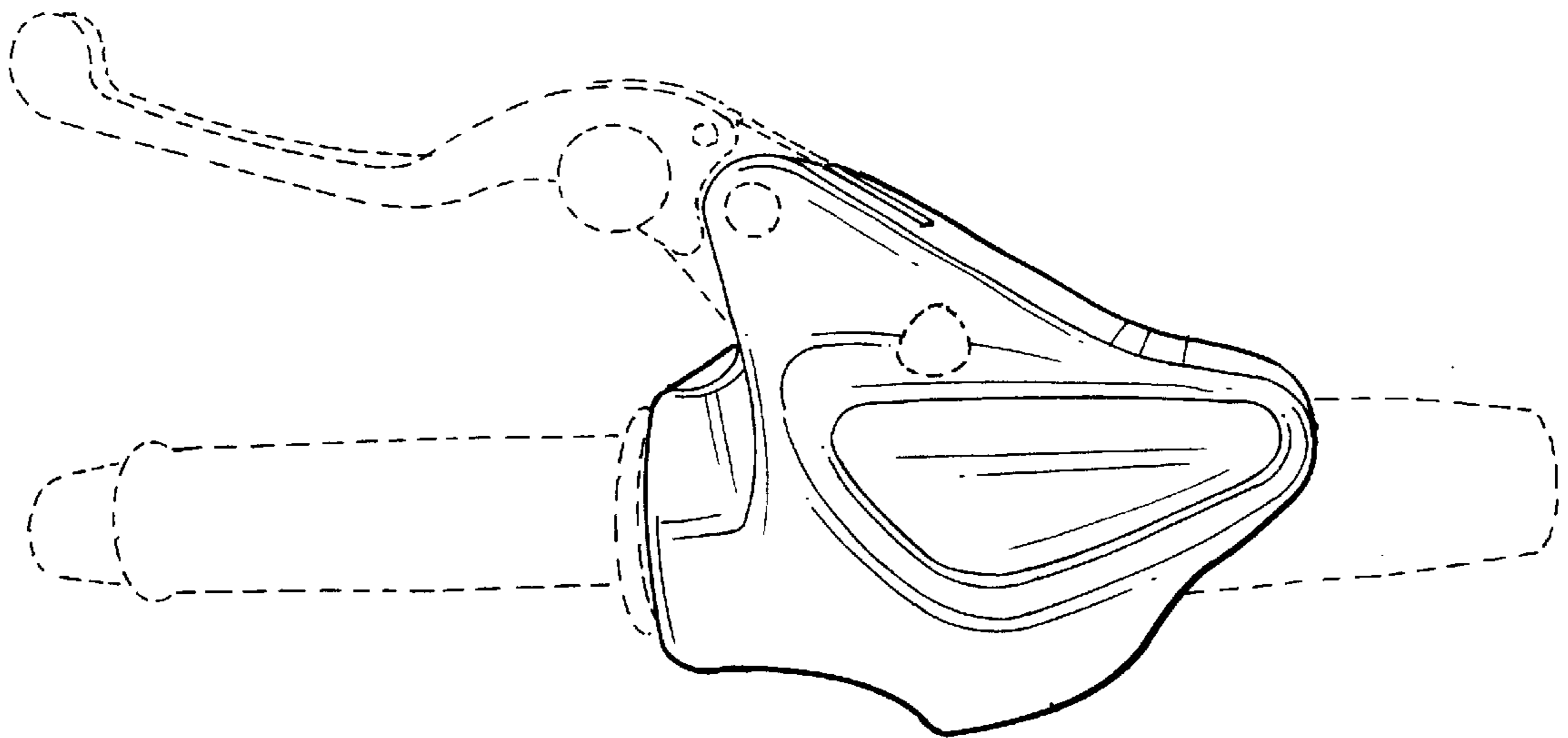

FIG. 5