



US00D454813S

(12) **United States Design Patent**
Boniface et al.

(10) **Patent No.:** **US D454,813 S**

(45) **Date of Patent:** **** Mar. 26, 2002**

(54) **VEHICLE BODY**

D420,939 S * 2/2000 Faurote et al. D12/91

(75) Inventors: **Robert E. Boniface**, Bloomfield Hills;
Timothy W. Anness, Rochester Hills;
John P. Sgalia, Farmington Hills;
Michael G. Moore, Shelby Township;
Trevor M. Creed, West Bloomfield, all
of MI (US)

* cited by examiner

Primary Examiner—Melody N. Brown
(74) *Attorney, Agent, or Firm*—Mark P Calcaterra

(73) Assignee: **DaimlerChrysler Corporation**, Auburn
Hills, MI (US)

(57) **CLAIM**

The ornamental design for a vehicle body, as shown and
described.

(**) Term: **14 Years**

DESCRIPTION

(21) Appl. No.: **29/134,440**

FIG. 1 is a front and left side perspective view of a first
embodiment of a vehicle body showing our new design.

(22) Filed: **Dec. 20, 2000**

FIG. 2 is a rear and left side perspective view thereof.

(51) **LOC (7) Cl.** **12-08**

FIG. 3 is a right side view thereof.

(52) **U.S. Cl.** **D12/91**

FIG. 4 is a left side view thereof.

(58) **Field of Search** D12/91, 96, 98;
296/183, 185, 186

FIG. 5 is a front view thereof.

FIG. 6 is a rear view thereof.

FIG. 7 is a rear view similar to FIG. 6, with the spare tire
removed to illustrate the detail therebehind; and,

(56) **References Cited**

U.S. PATENT DOCUMENTS

D336,266 S	6/1993	Hunter et al.	D12/98
D350,504 S	9/1994	Nixon	D12/91
D352,485 S	11/1994	Creed et al.	D12/98
D357,213 S	4/1995	Hunter et al.	D12/98
D365,783 S	1/1996	Starr et al.	D12/91
D373,979 S	9/1996	Starr et al.	D12/98
D389,438 S	* 1/1998	Guichard et al.	D12/98
D396,203 S	7/1998	Uematsu et al.	D12/91
D396,828 S	8/1998	Baccus et al.	D12/91
D397,065 S	8/1998	Uematsu et al.	D12/91
D401,185 S	11/1998	McGovern	D12/91
D416,519 S	11/1999	Won et al.	

FIG. 8 is a rear view of a second embodiment of our design,
it being understood that the only differences from the first
embodiment are the omission of the bumper recess to
accommodate a spare tire and the license plate mounting
area, the remaining details of the second embodiment are
identical to corresponding second embodiment are identical
to corresponding details shown with respect to the first
embodiment.

It will be understood that the broken lines showing of the
wheels, tires, body side molding, and hinges throughout the
drawings is for illustrative purposes only and forms no part
of the claimed design. It will be further understood that the
top is plain and unornamental.

1 Claim, 6 Drawing Sheets

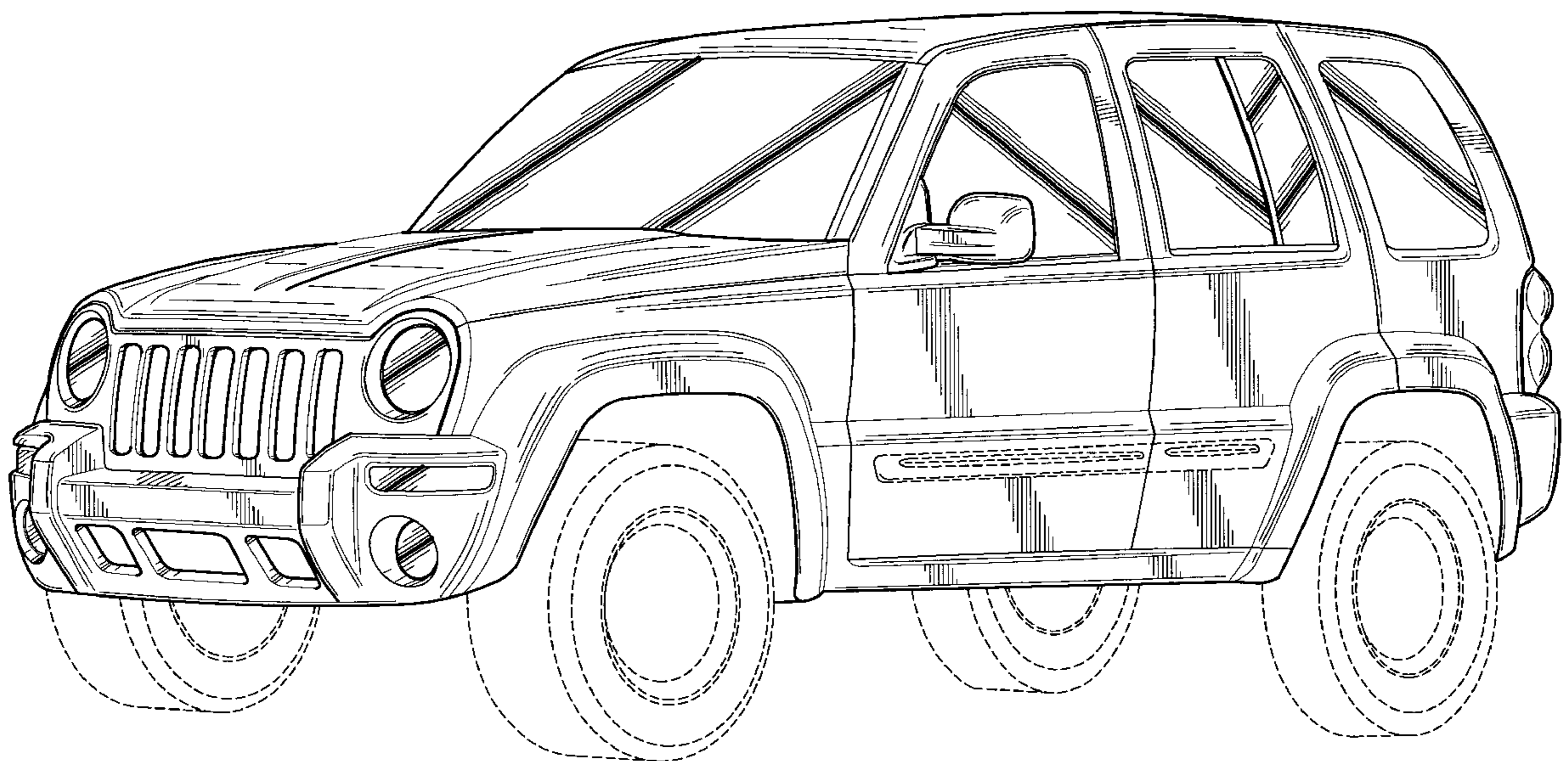

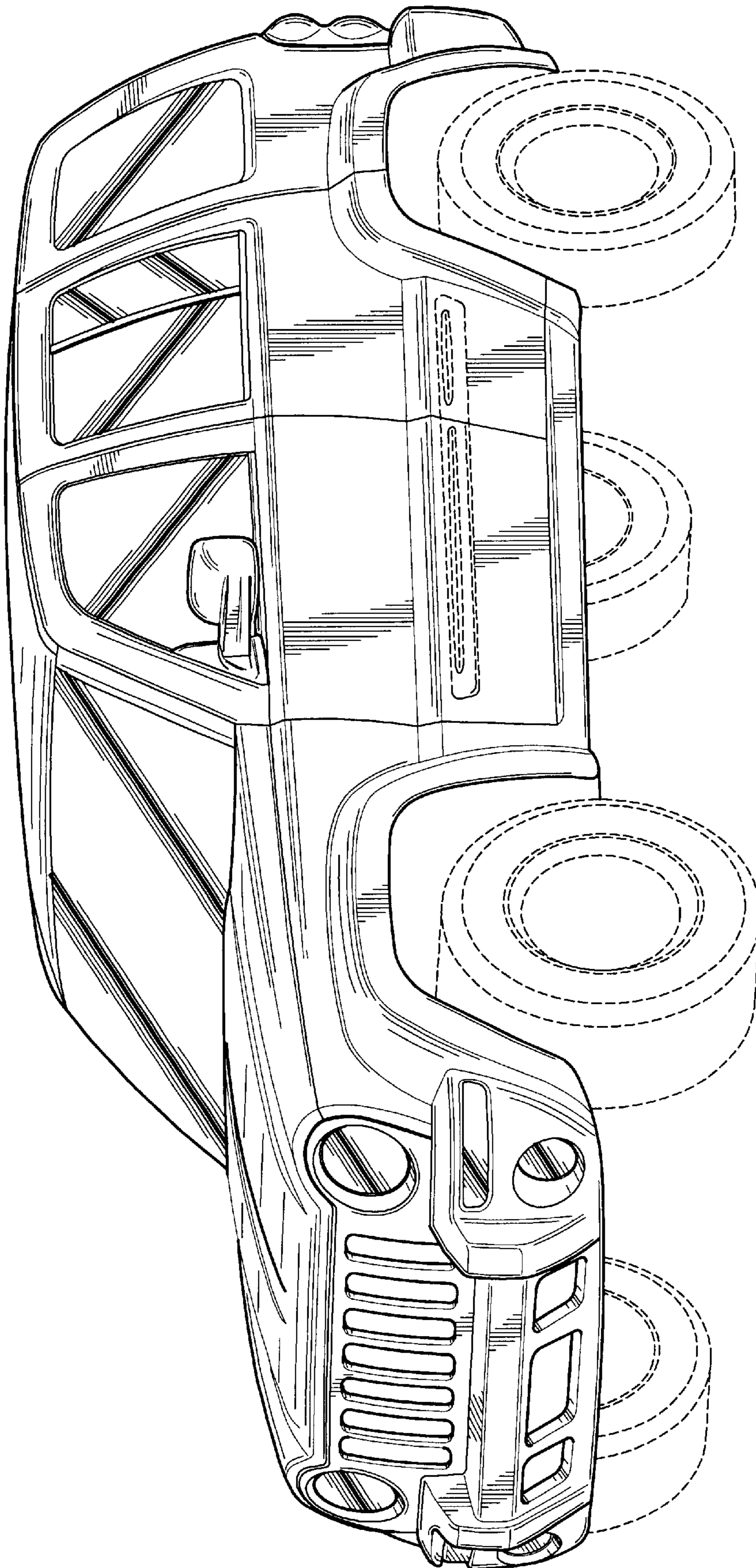

Figure - 1

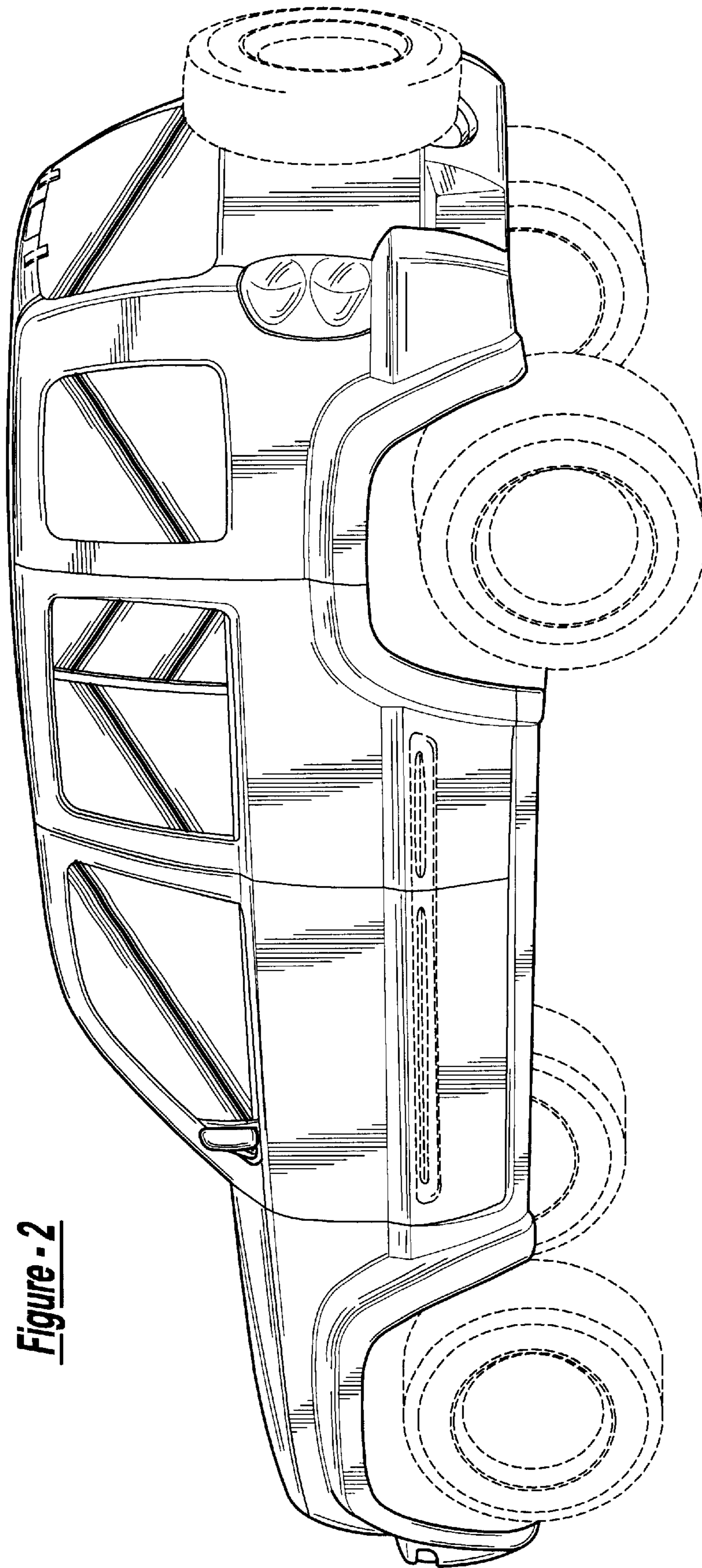

Figure - 2

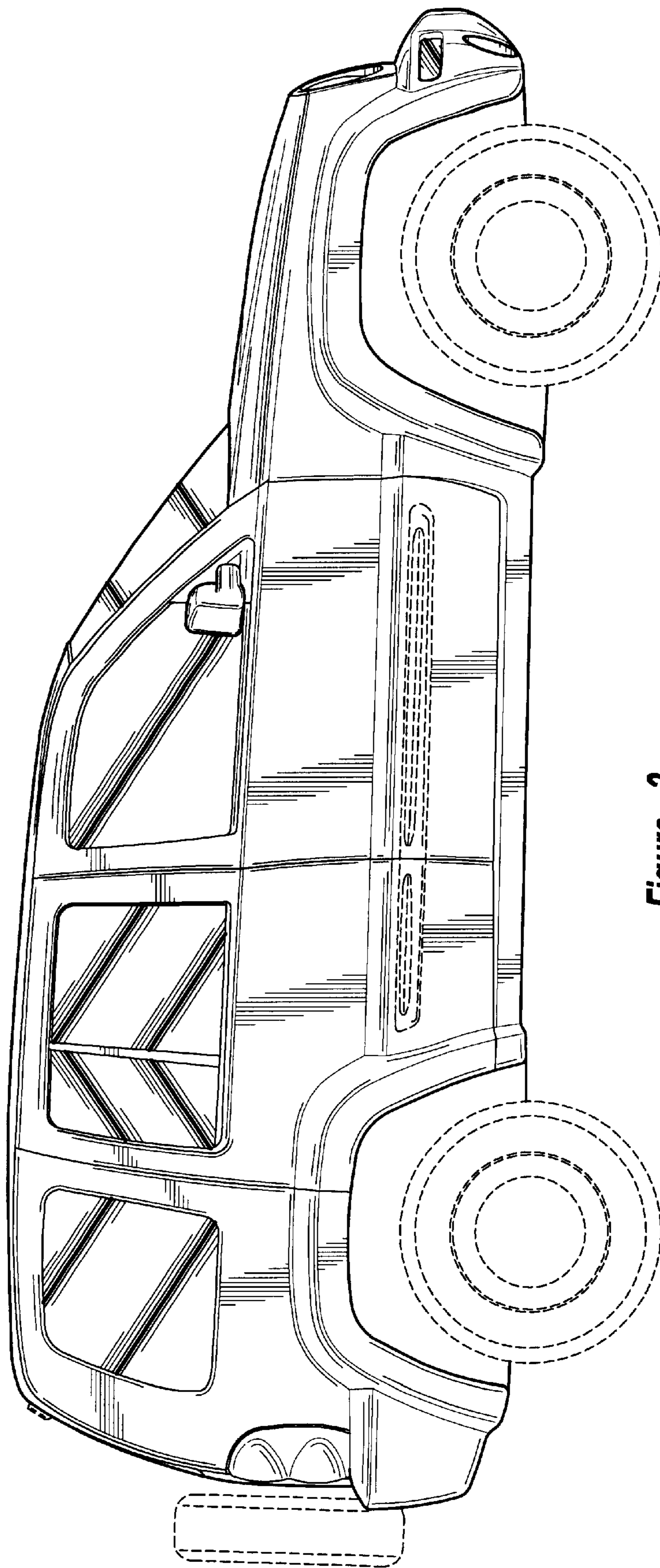

Figure - 3

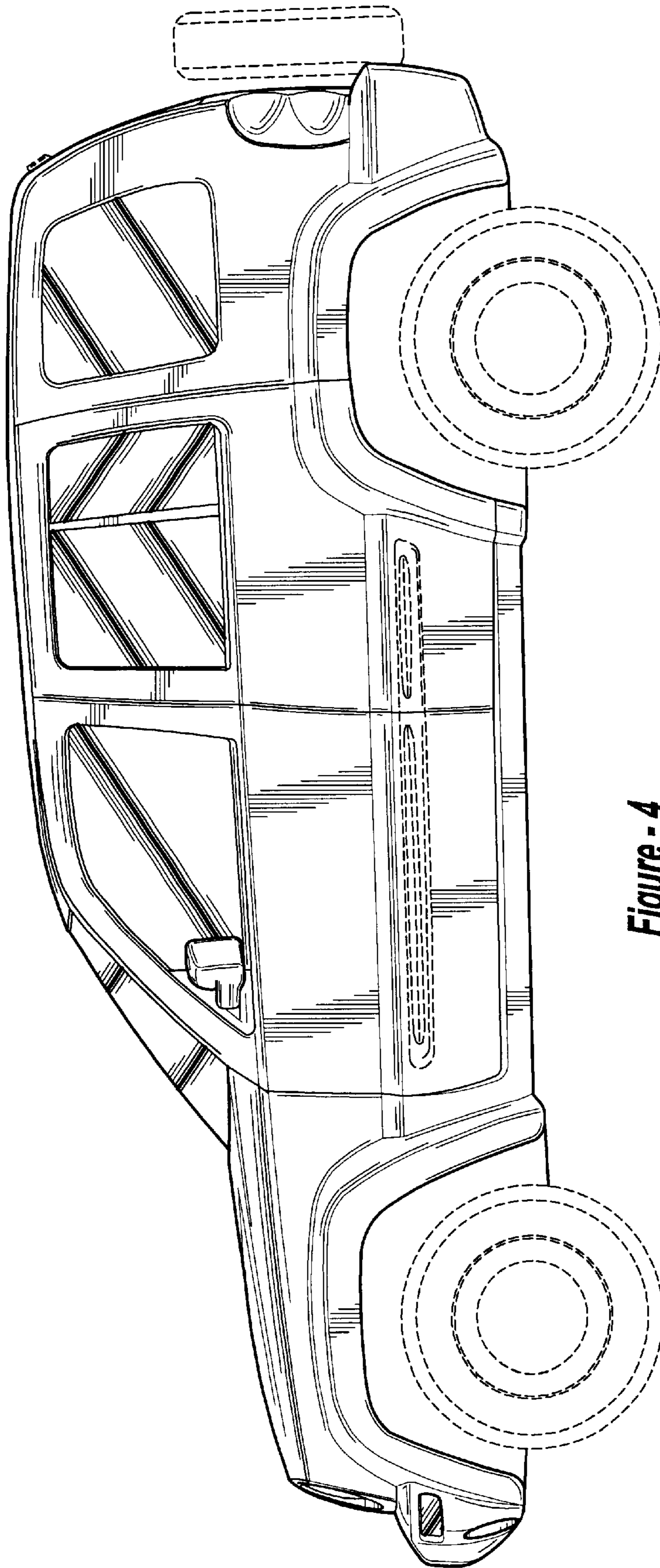

Figure - 4

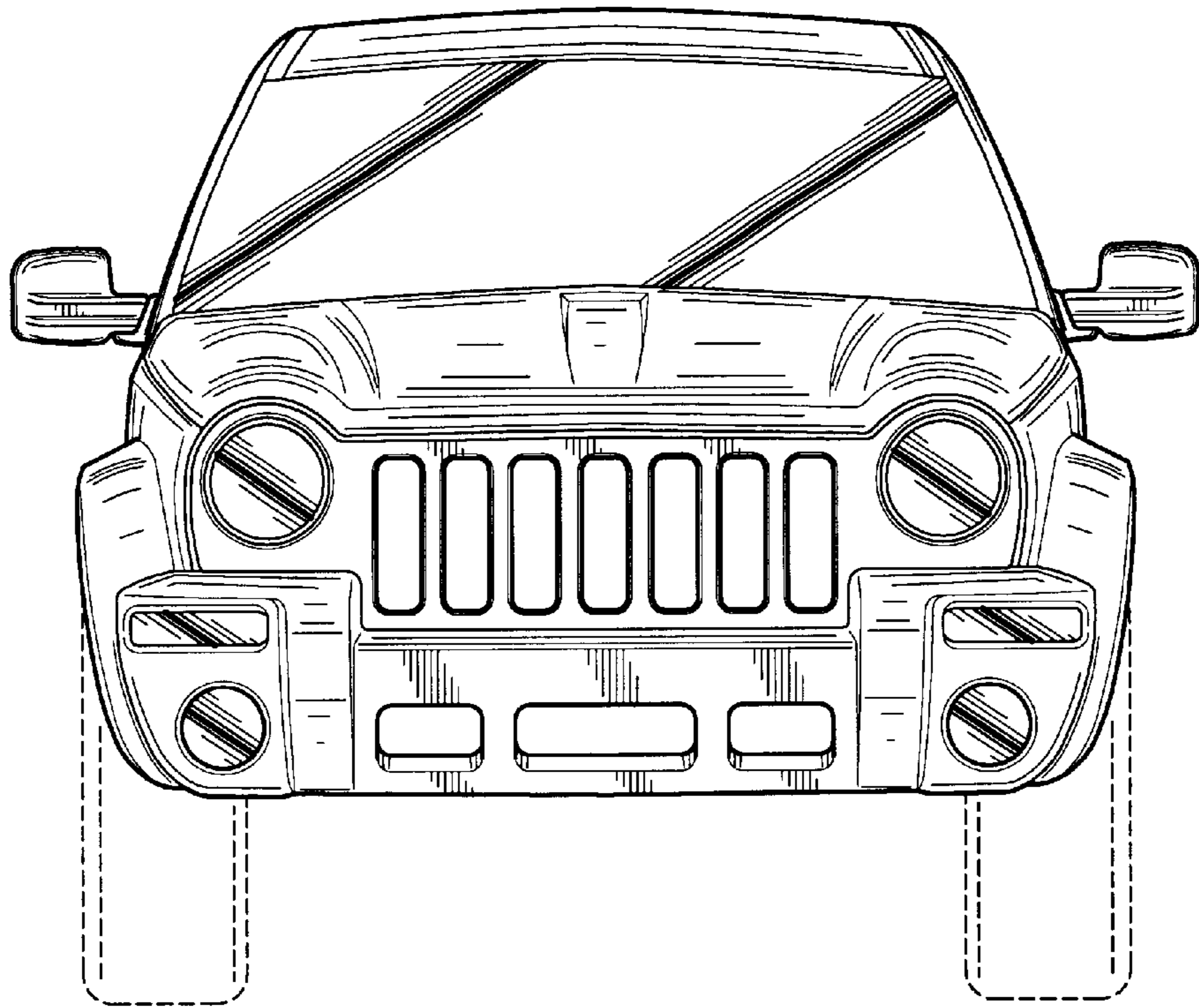

Figure - 5

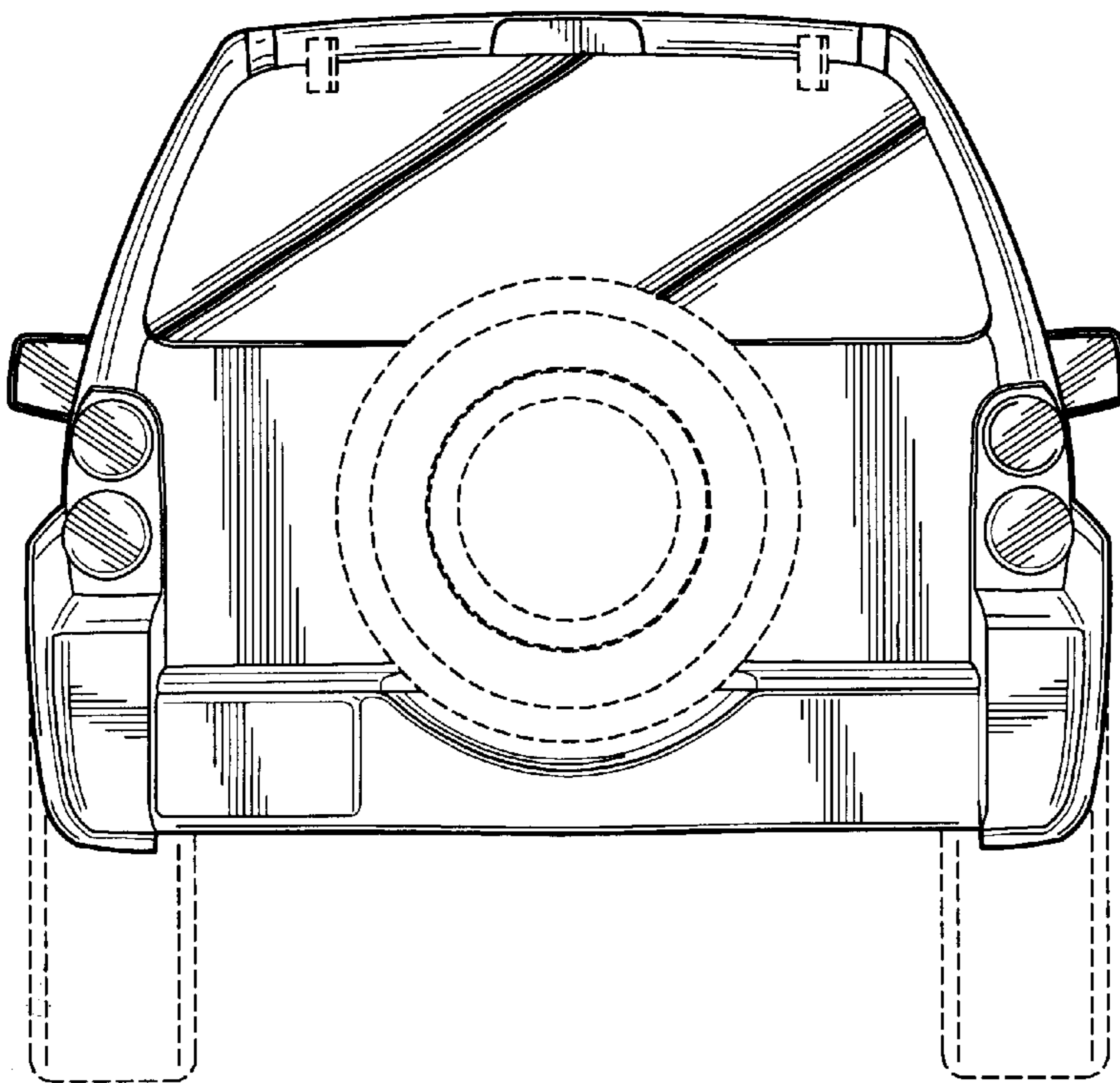

Figure - 6

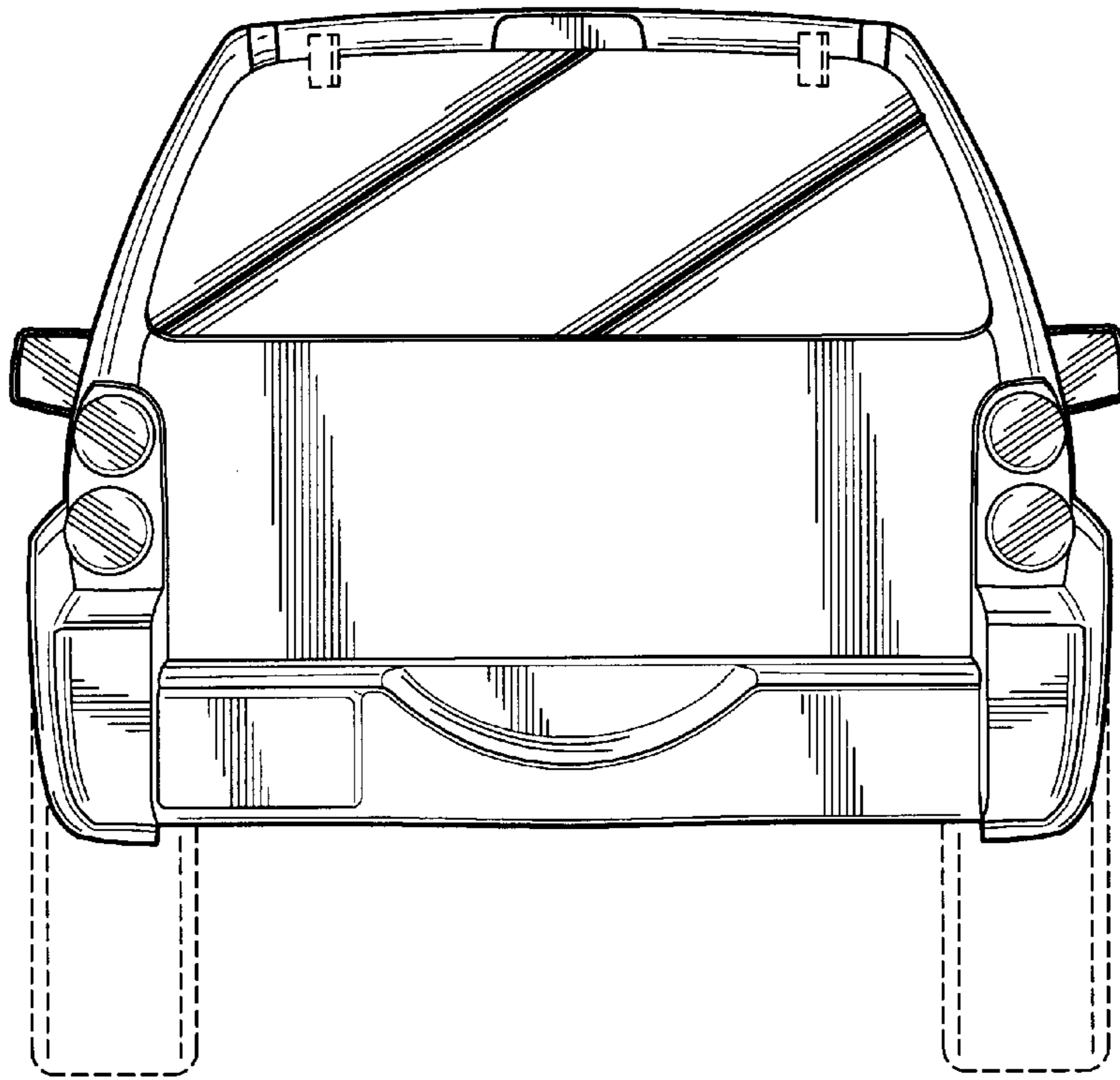

Figure - 7

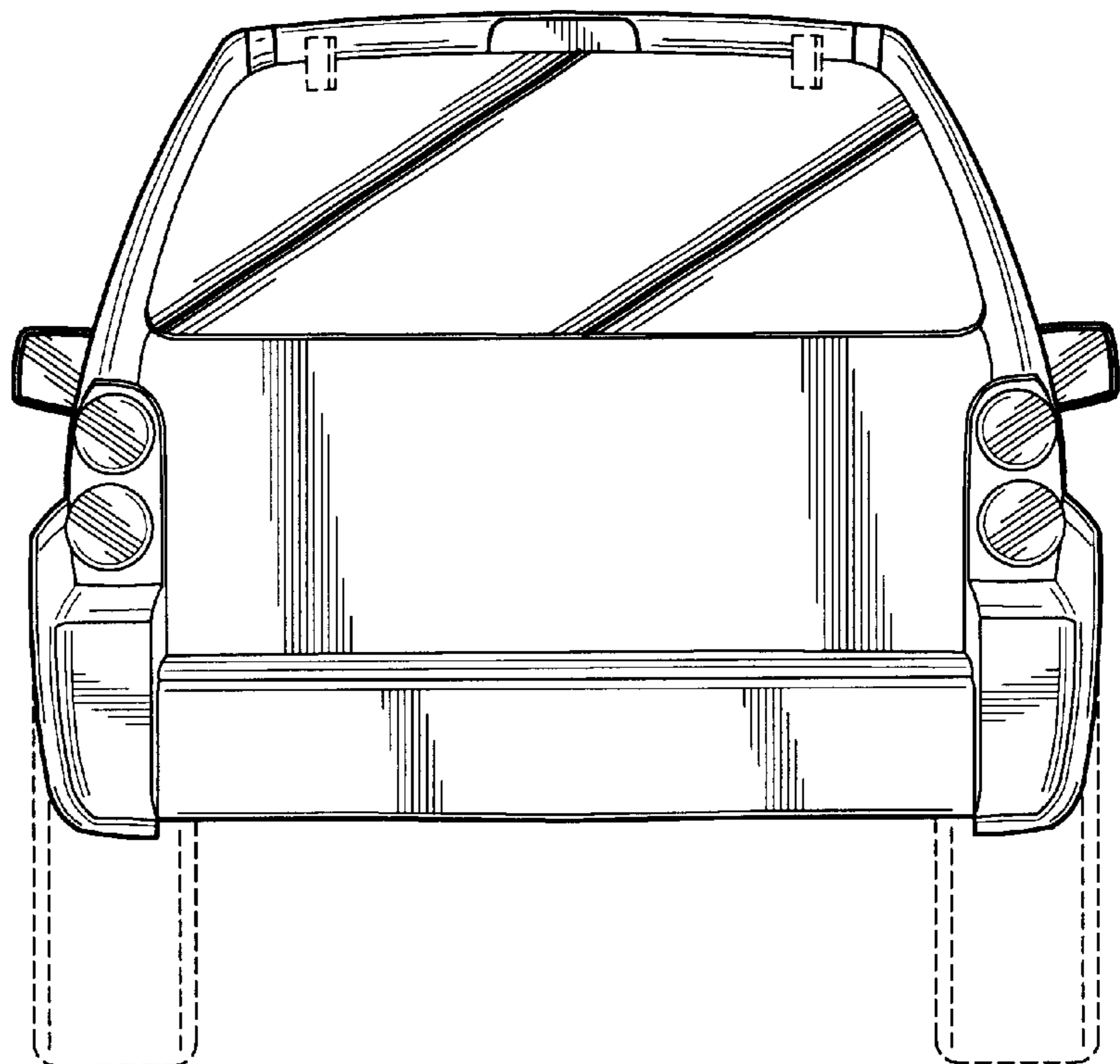

Figure - 8