



US00D454532S

(12) **United States Design Patent**
Lourens

(10) **Patent No.:** **US D454,532 S**
(45) **Date of Patent:** **** Mar. 19, 2002**

(54) **TWO-WHEELER LUGGAGE SUITCASE**

4,588,114 A * 5/1986 Lebaron et al. 224/435

(75) Inventor: **Minguelita M. Lourens**, Curacao (AN)

OTHER PUBLICATIONS

(73) Assignee: **Taloco Investments NV**, Curacao (AN)

JC Whitney Fall 1999 motorcycle catalog No. 88J-10, travel trunks illustrated on p. 26.*

(**) Term: **14 Years**

* cited by examiner

(21) Appl. No.: **29/138,203**

Primary Examiner—Alan P. Douglas

(22) Filed: **Mar. 9, 2001**

Assistant Examiner—Linda Brooks

(30) **Foreign Application Priority Data**

(74) *Attorney, Agent, or Firm*—Smith, Gambrell & Russell, LLP

Sep. 12, 2000 (IT) PI0000009

(57) **CLAIM**

(51) **LOC (7) Cl.** **12-16**

The ornamental design for a two-wheeler luggage suitcase, as shown and described.

(52) **U.S. Cl.** **D12/410**

(58) **Field of Search** D12/407, 409, D12/410, 110, 111; D3/231, 273, 276; 180/219; 280/288.4; 190/101, 115-127; 224/400, 412, 413, 415, 416, 417, 419-425, 428-435, 315

DESCRIPTION

(56) **References Cited**

FIG. 1 is a perspective view of a two-wheeler luggage suitcase showing my new design;
FIG. 2 shows a top plan view thereof;
FIG. 3 shows a bottom plan view thereof;
FIG. 4 shows a left side elevation view thereof;
FIG. 5 shows a right side elevation view thereof;
FIG. 6 shows a front elevational view thereof; and,
FIG. 7 shows a rear elevational view thereof.

U.S. PATENT DOCUMENTS

3,029,915 A * 4/1962 Axtell 190/115
4,241,857 A * 12/1980 Perethian et al. 224/413
D276,712 S * 12/1984 Kashio et al. D12/410

1 Claim, 4 Drawing Sheets

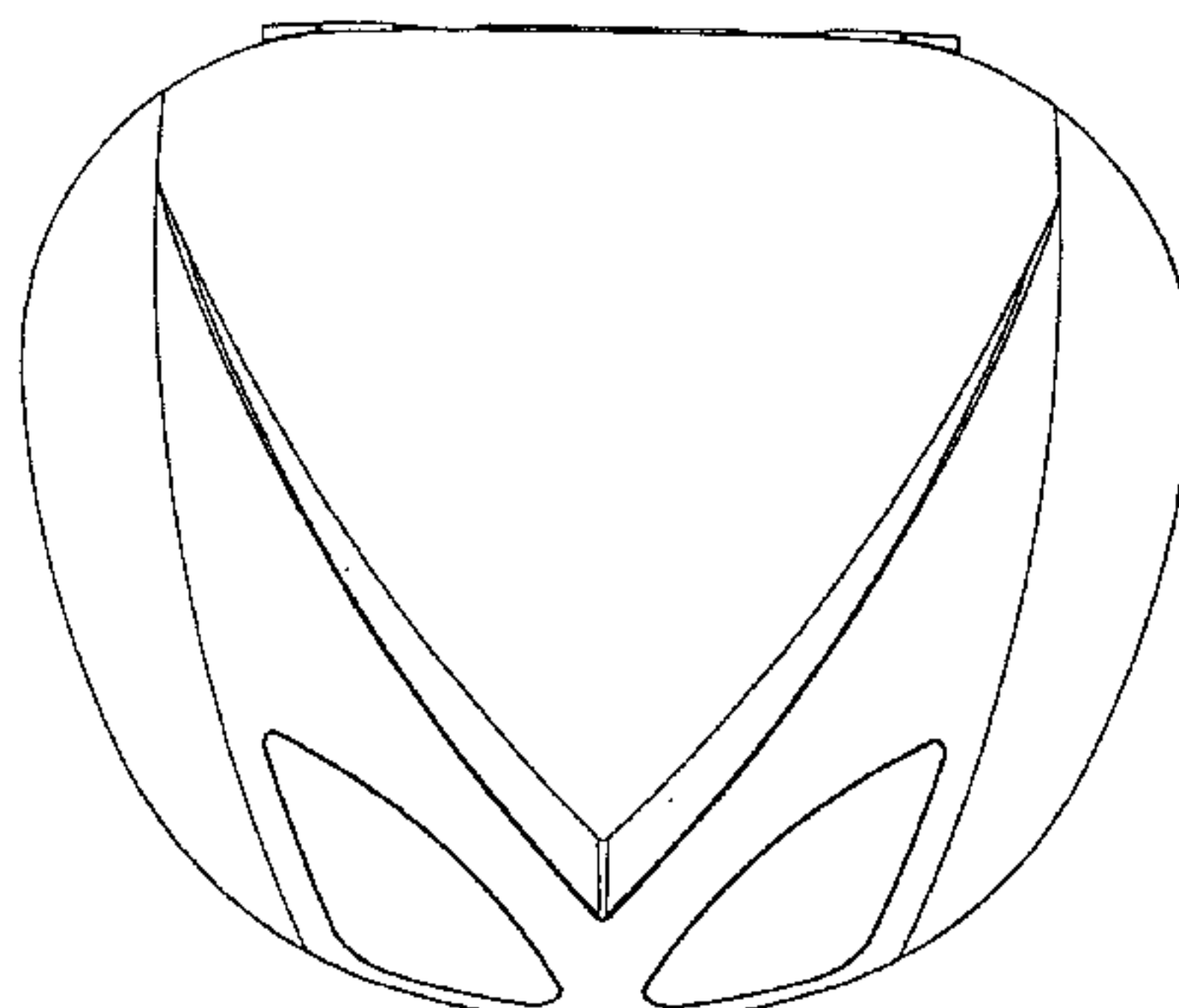
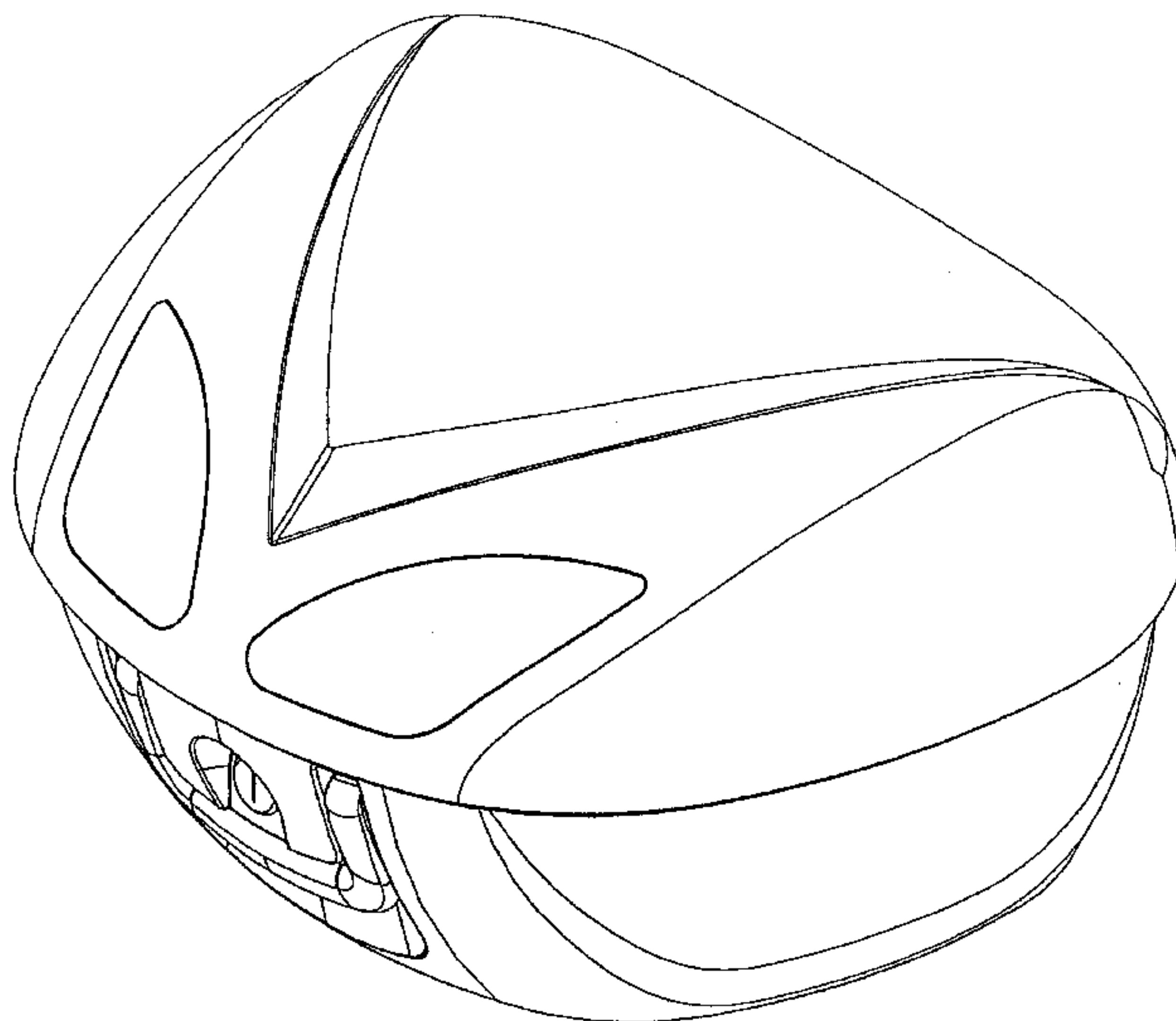

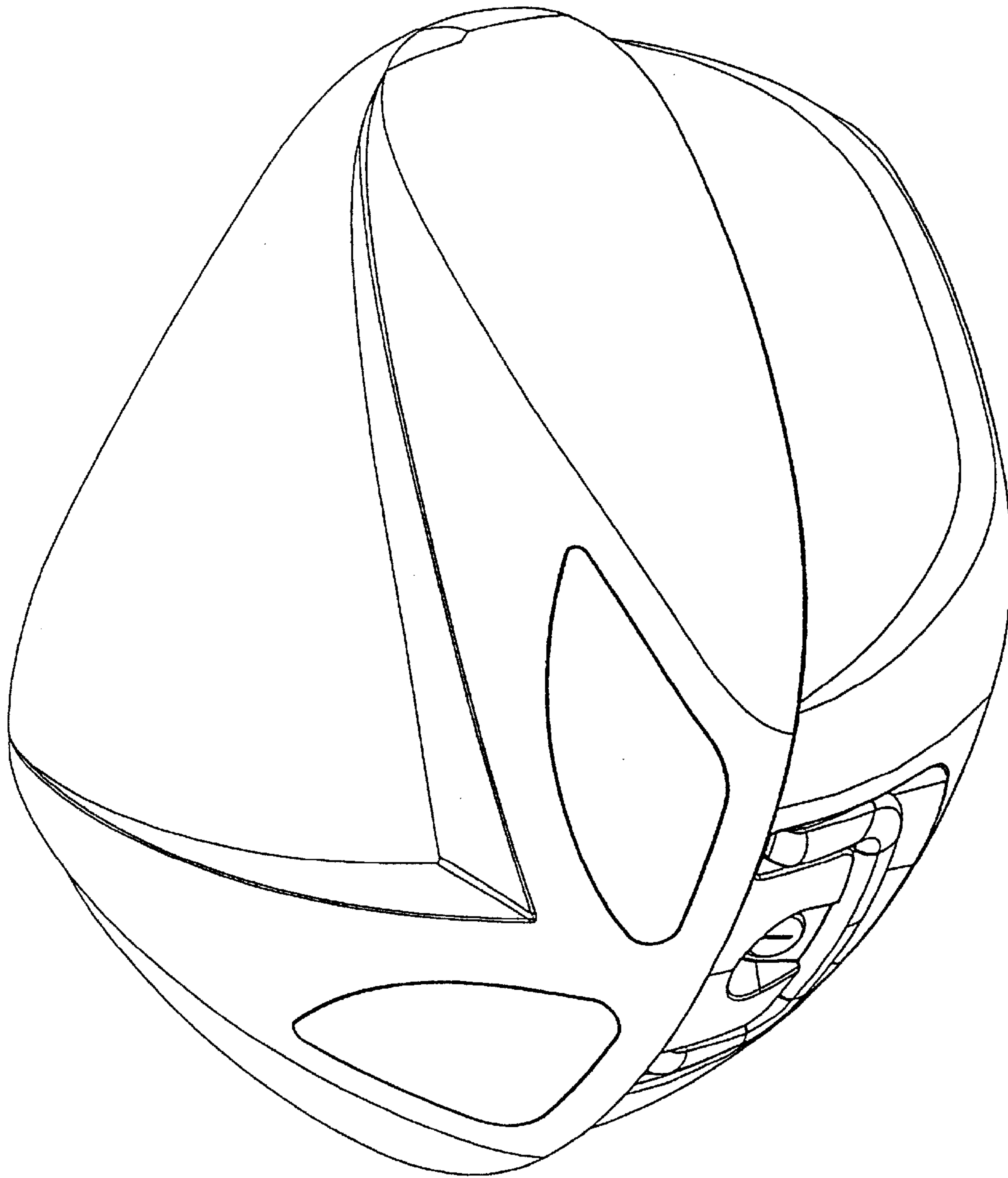

FIG. 1

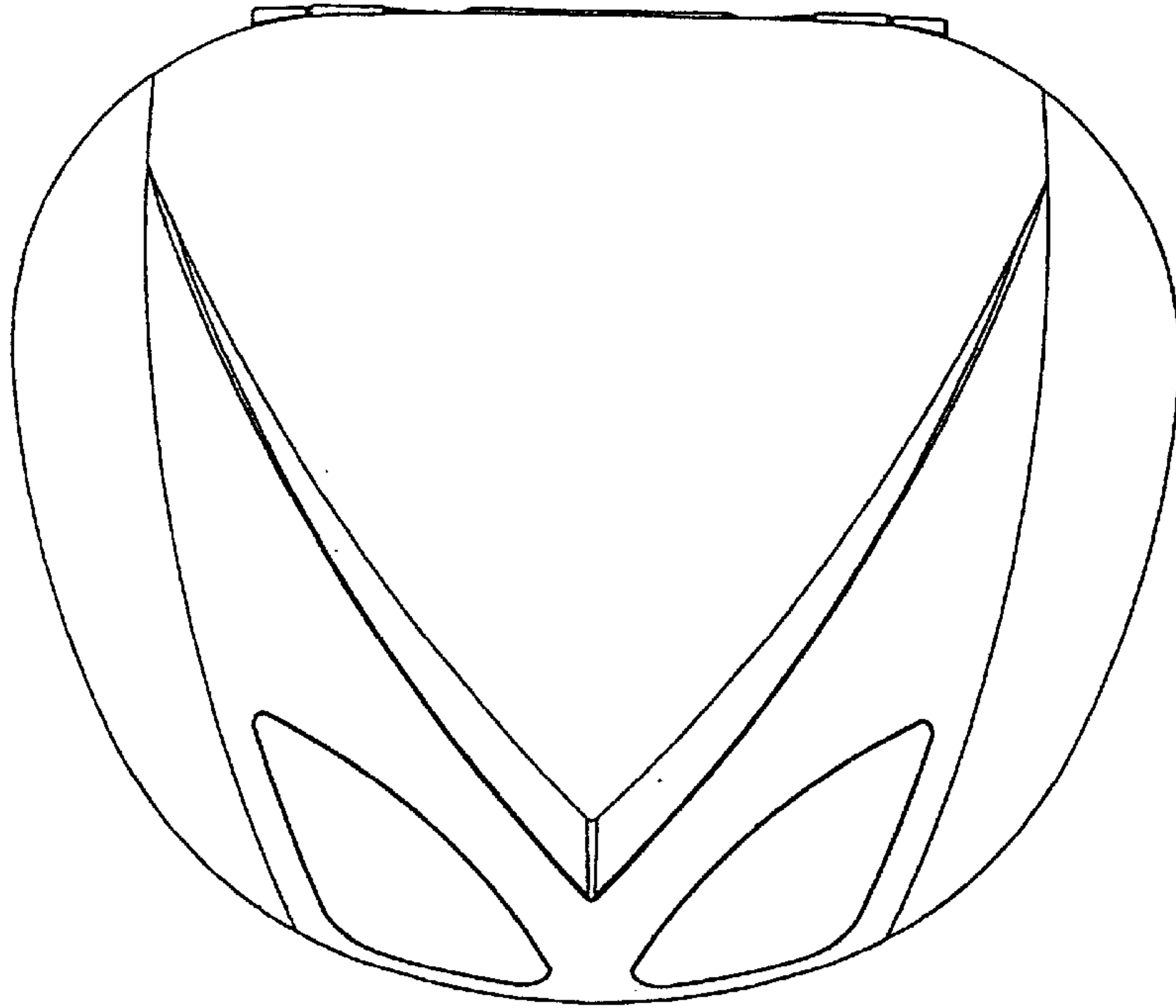

FIG. 2

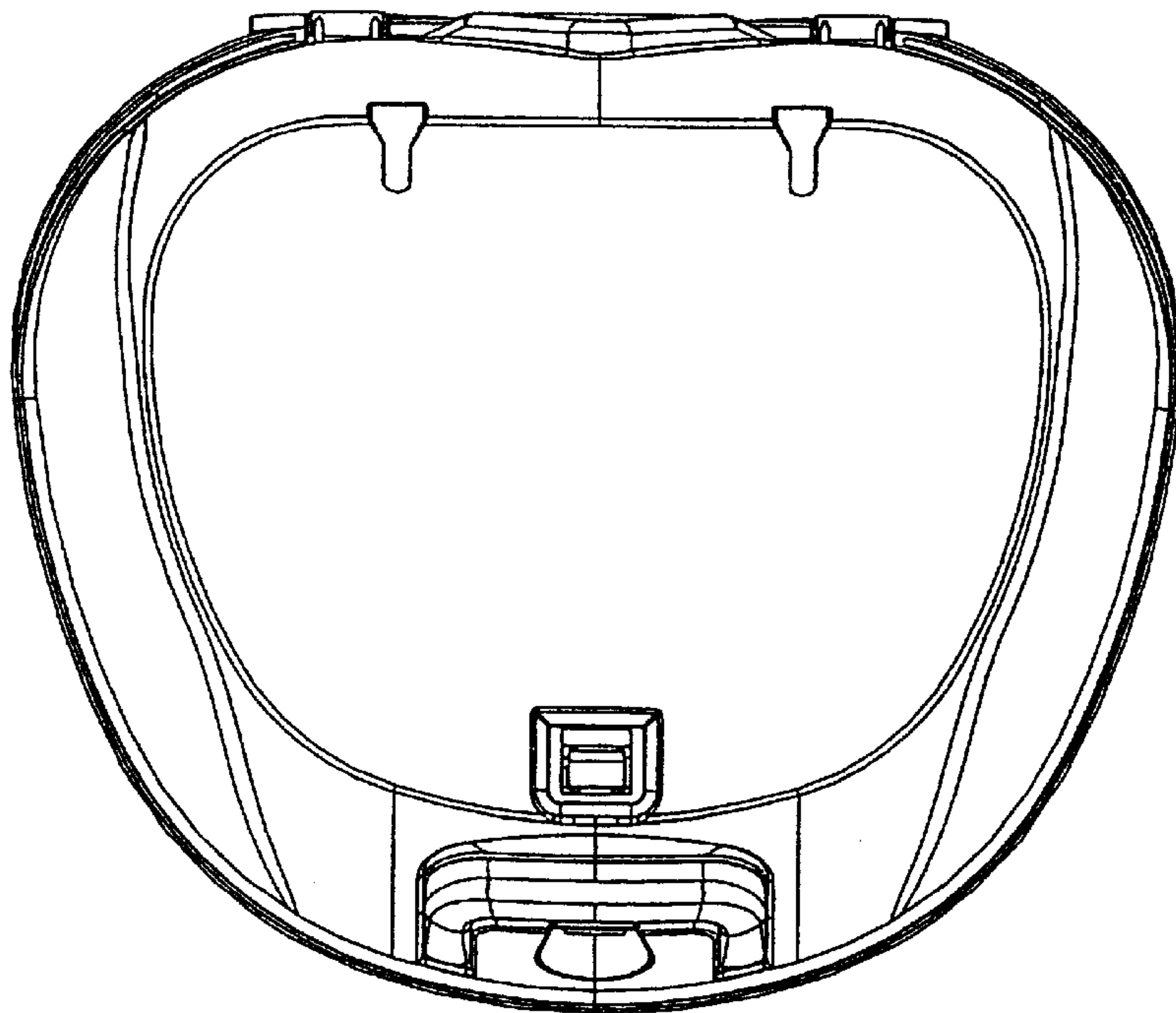

FIG. 3

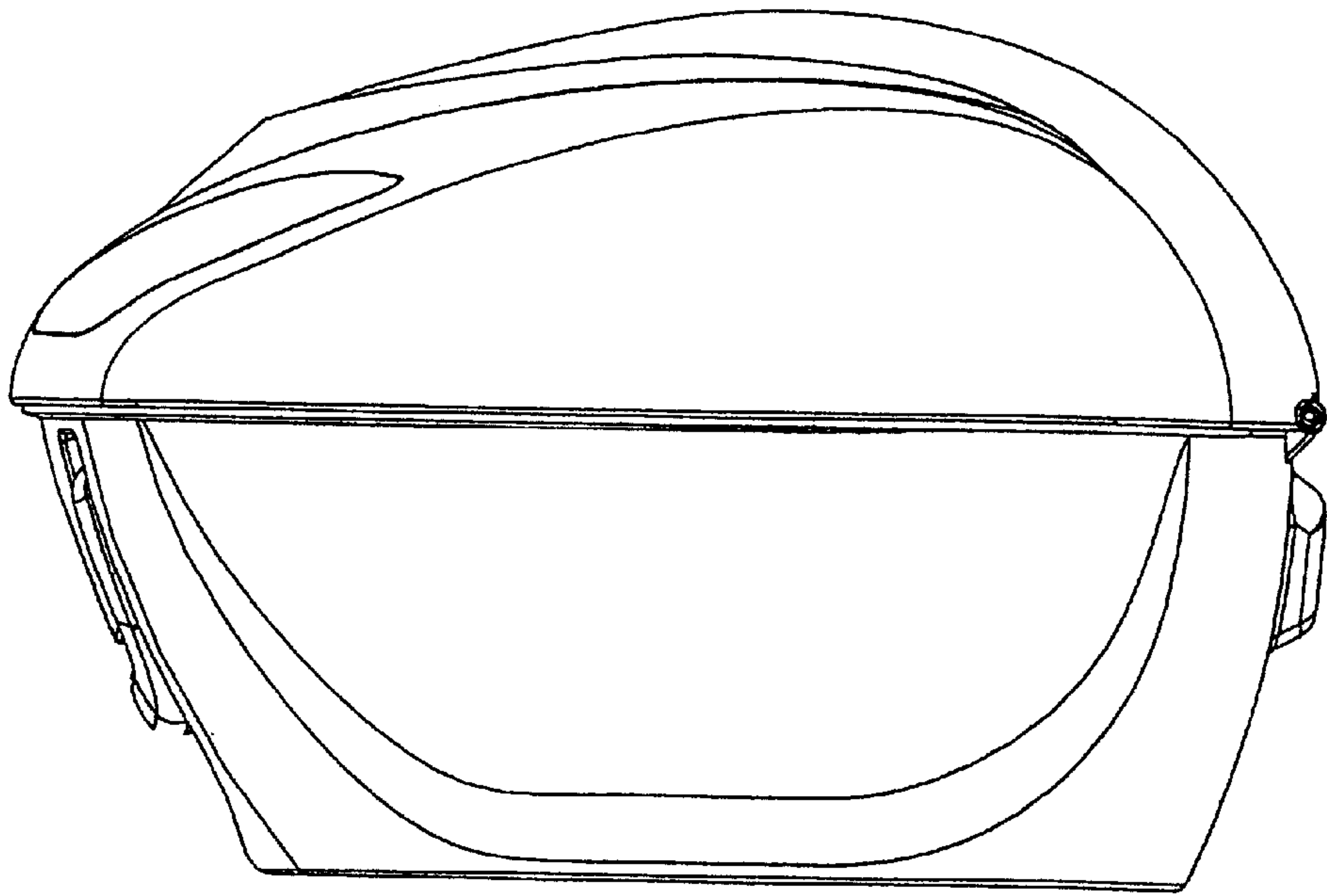

FIG. 4

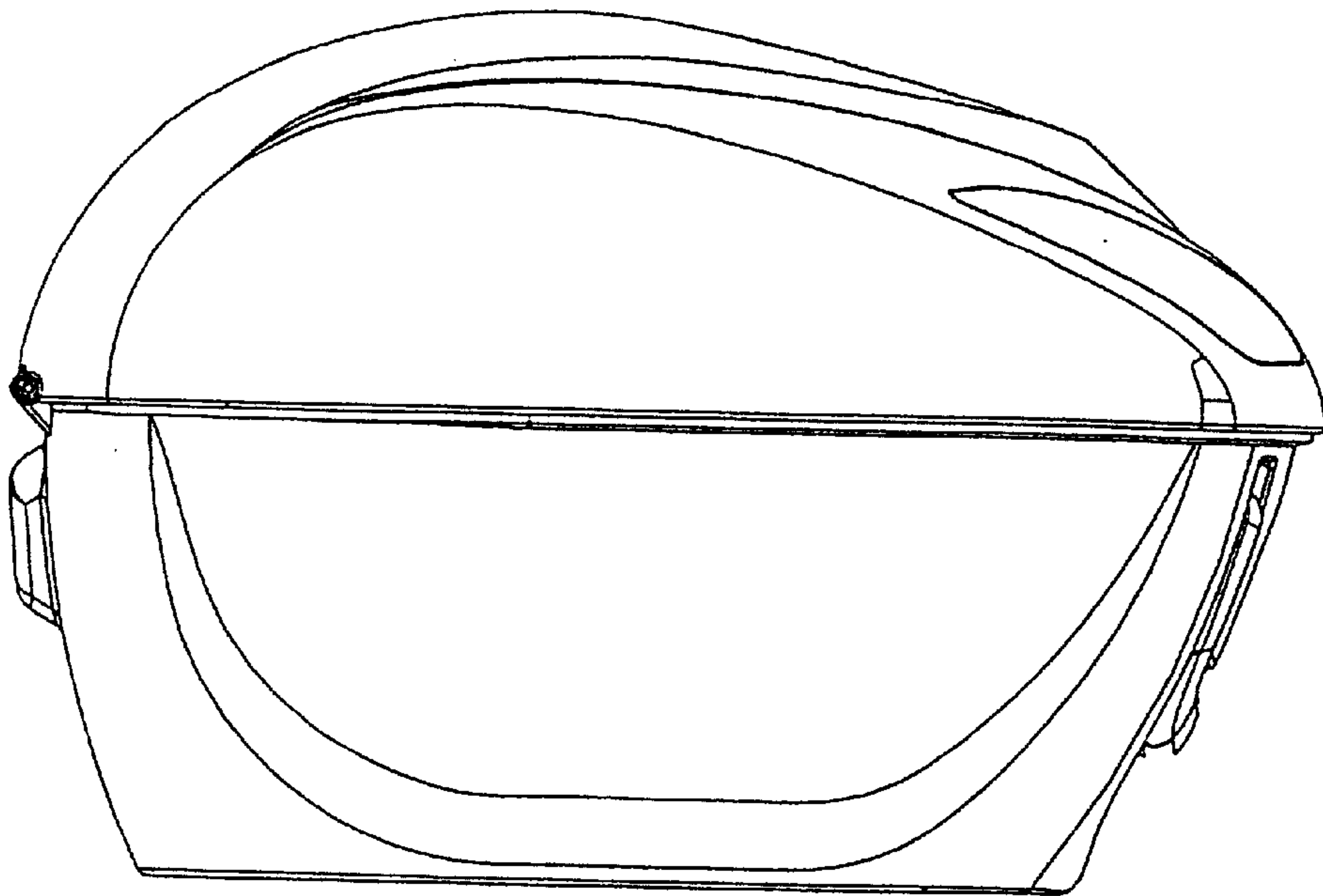

FIG. 5

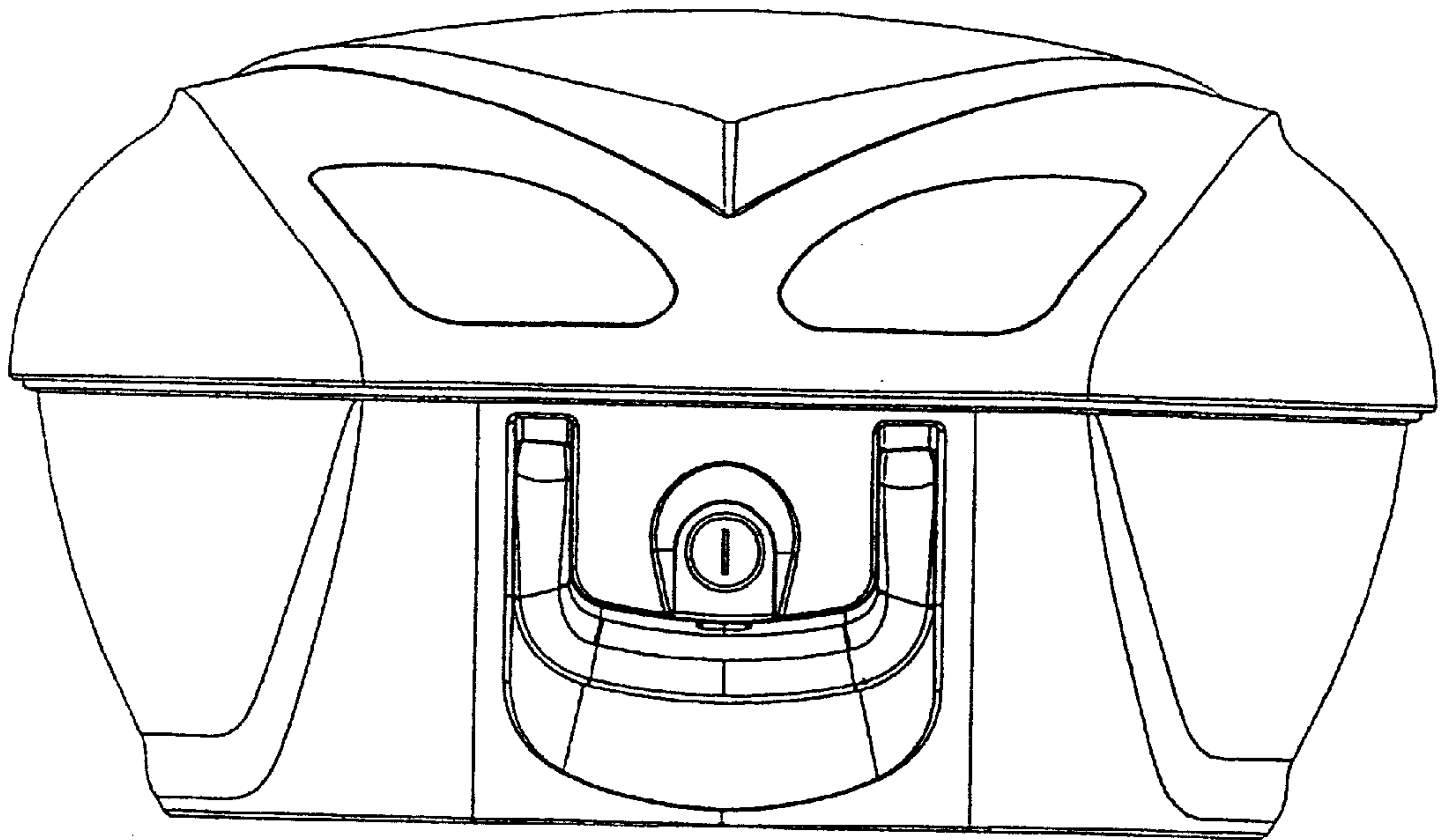

FIG. 6

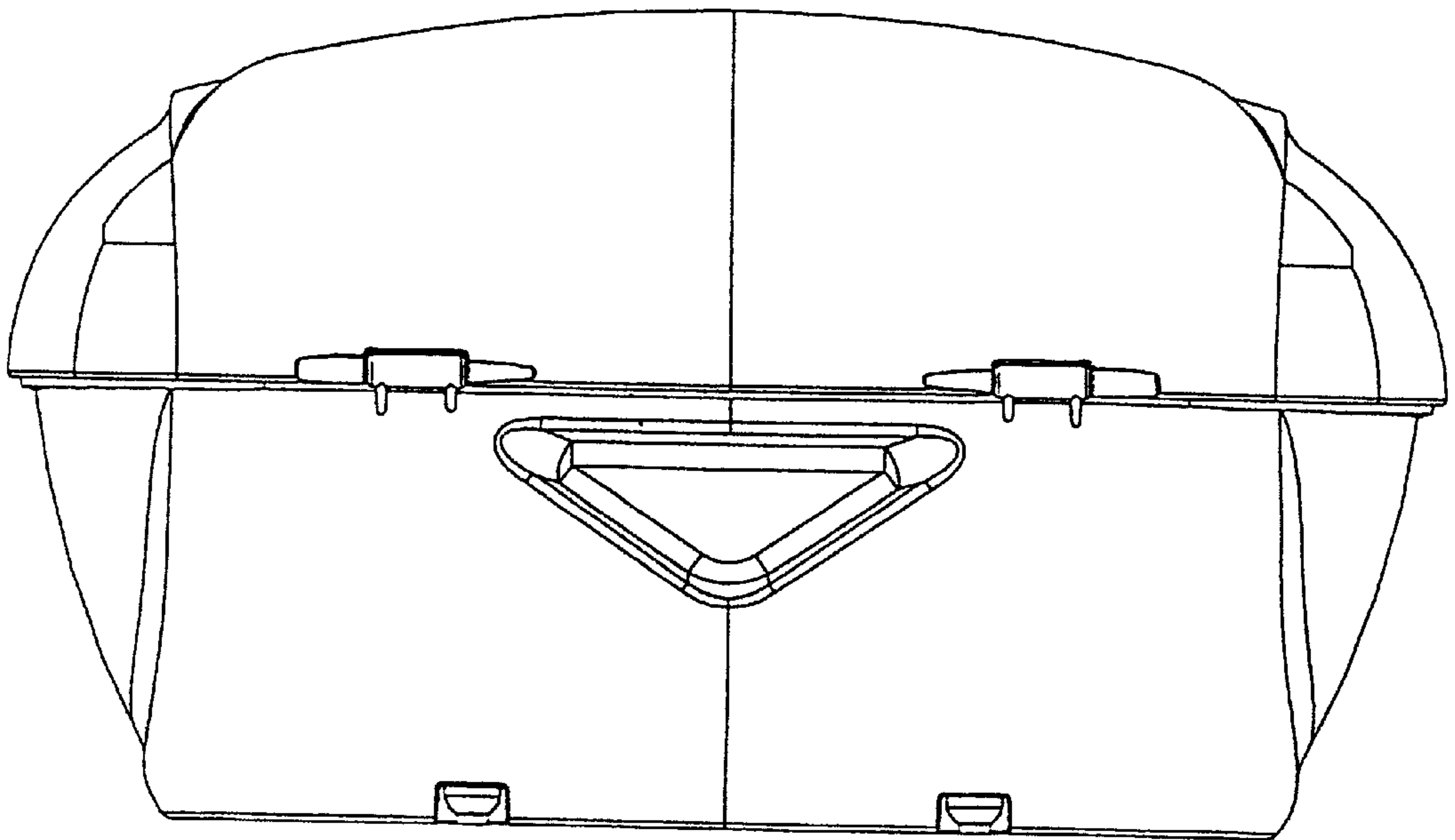

FIG. 7