



US00D454529S

(12) **United States Design Patent**
Pfeiffer et al.

(10) **Patent No.:** **US D454,529 S**
(45) **Date of Patent:** **** Mar. 19, 2002**

(54) **FRONT FACE OF A VEHICLE WHEEL**

(75) Inventors: **Peter Pfeiffer**, Boeblingen; **Gerhard Honer**, Weil der Stadt; **Oliver Stick**, Aidlingen, all of (DE)

(73) Assignee: **DaimlerChrysler AG**, Stuttgart (DE)

(**) Term: **14 Years**

(21) Appl. No.: **29/139,682**

(22) Filed: **Apr. 5, 2001**

(30) **Foreign Application Priority Data**

Oct. 5, 2000 (DE) 4 00 09 382

(51) **LOC (7) Cl.** **12-16**

(52) **U.S. Cl.** **D12/210**

(58) **Field of Search** D12/204-211;
301/37.1, 64.1, 65

(56) **References Cited**

U.S. PATENT DOCUMENTS

D56,136 S * 8/1920 Gilbert D12/210

D219,967 S * 2/1971 Harty D12/210
D361,975 S * 9/1995 Weld D12/210
D430,094 S * 8/2000 Hale, Jr. D12/210
D436,910 S * 1/2001 Hale, Jr. D12/210
D451,064 S * 11/2001 Cormican D12/210

* cited by examiner

Primary Examiner—Stacia Cadmus

(74) *Attorney, Agent, or Firm*—Crowell & Moring LLP

(57) **CLAIM**

The ornamental design for a front face of a vehicle wheel, as shown and described.

DESCRIPTION

FIG. 1 is a front view of a front face of a vehicle wheel according to our novel design; and,

FIG. 2 is a perspective view of the front face of a vehicle wheel according to our novel design.

1 Claim, 1 Drawing Sheet

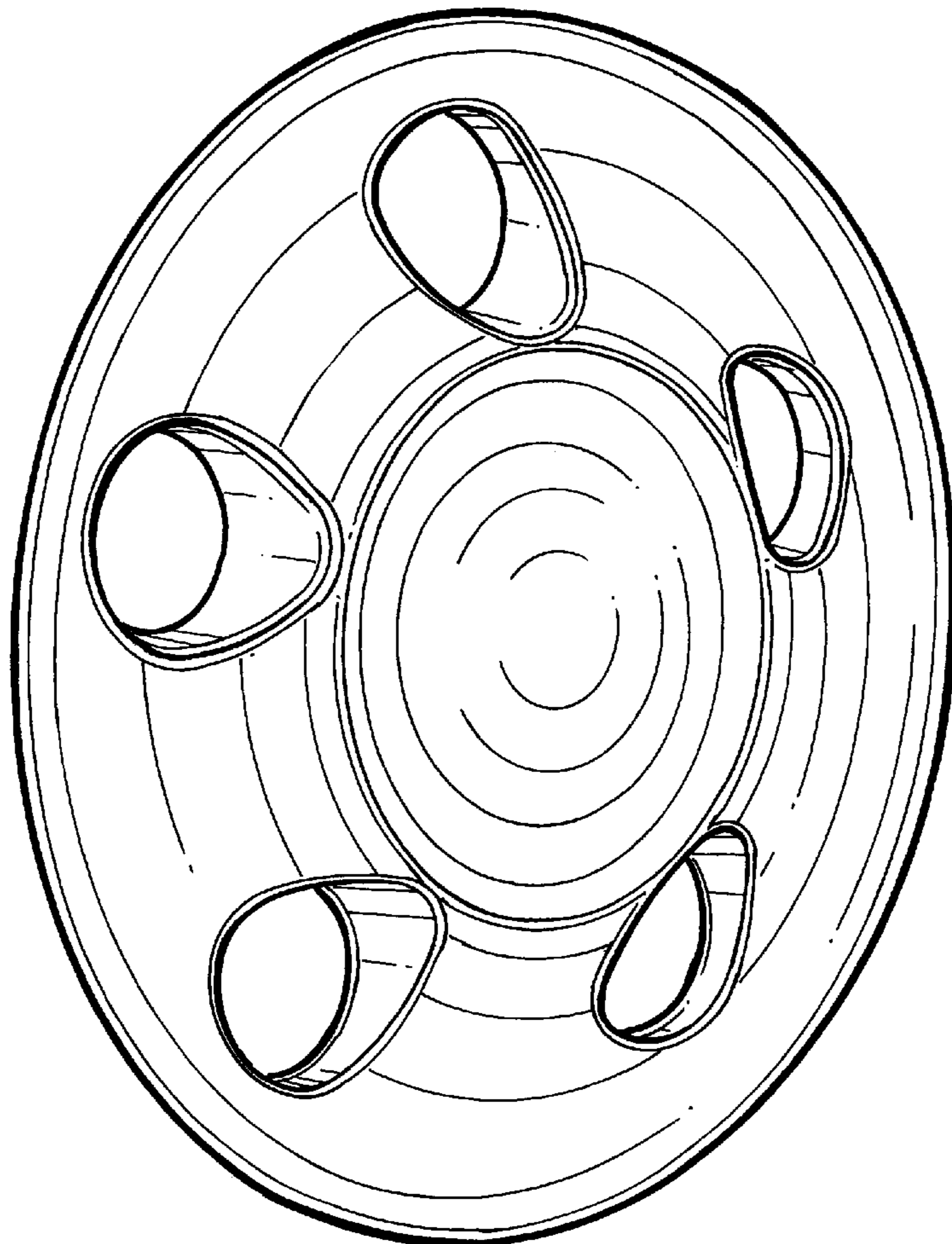

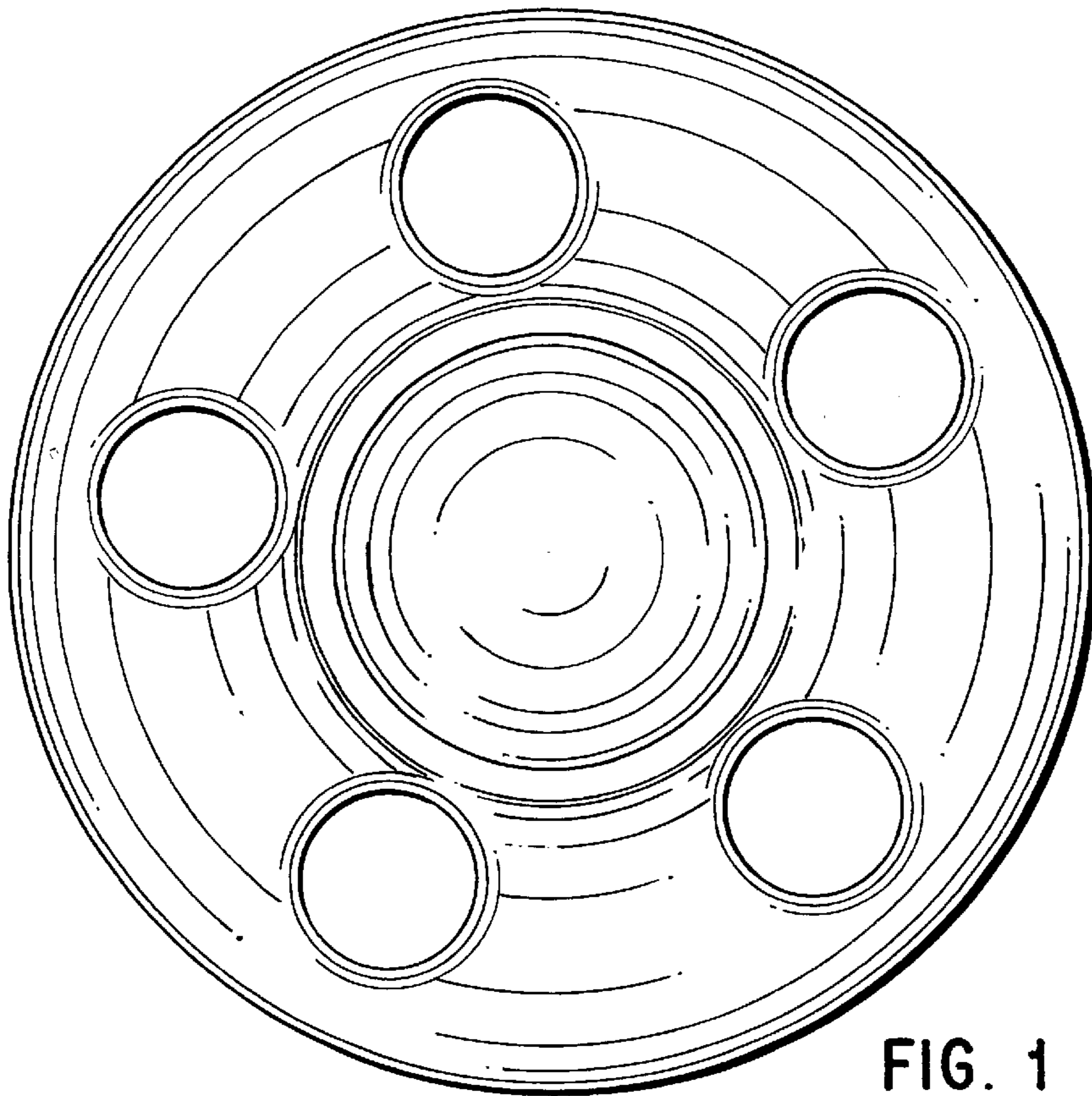

FIG. 1

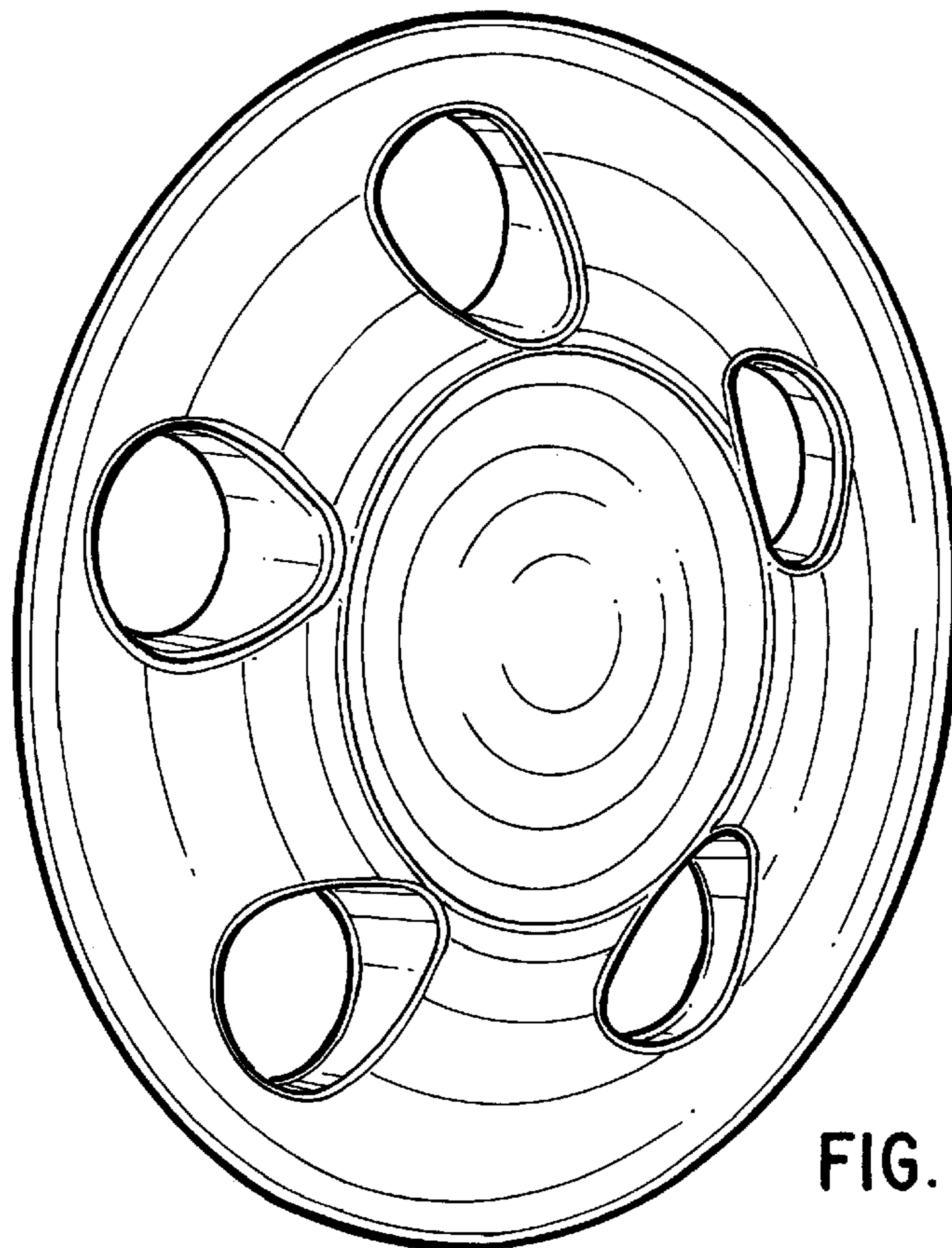

FIG. 2