



US00D454509S

(12) **United States Design Patent**  
**Chiang**

(10) **Patent No.:** **US D454,509 S**

(45) **Date of Patent:** **\*\* Mar. 19, 2002**

(54) **NUT AND BOLT THREAD IDENTIFIER DEVICE**

*Primary Examiner*—Antoine Duval Davis  
(74) *Attorney, Agent, or Firm*—John J. Leavitt

(76) **Inventor:** **John Chiang**, 3274 Ettie St., Oakland, CA (US) 94608

(57) **CLAIM**

(\*\*) **Term:** **14 Years**

The ornamental design for a nut and bolt thread identifier device, as shown.

(21) **Appl. No.:** **29/138,279**

**DESCRIPTION**

(22) **Filed:** **Mar. 9, 2001**

(51) **LOC (7) Cl.** ..... **10-04**

FIG. 1 is a perspective view of the nut and bolt thread identifier device.

(52) **U.S. Cl.** ..... **D10/64**

FIG. 2 is a front elevational view thereof.

(58) **Field of Search** ..... D10/64; 33/555.1, 33/555.2, 562, 563

FIG. 3 is a top plan view thereof.

FIG. 4 is a left side elevational view thereof.

(56) **References Cited**

FIG. 5 is a right side elevational view thereof.

**U.S. PATENT DOCUMENTS**

FIG. 6 is a bottom plan view thereof; and,

FIG. 7 is a rear elevational view thereof.

5,131,162 A *	7/1992	Miller	.....	33/555.2 X
D366,843 S *	2/1996	Rosenstein	.....	D10/64
5,501,020 A *	3/1996	Welt	.....	33/555.2

\* cited by examiner

**1 Claim, 3 Drawing Sheets**

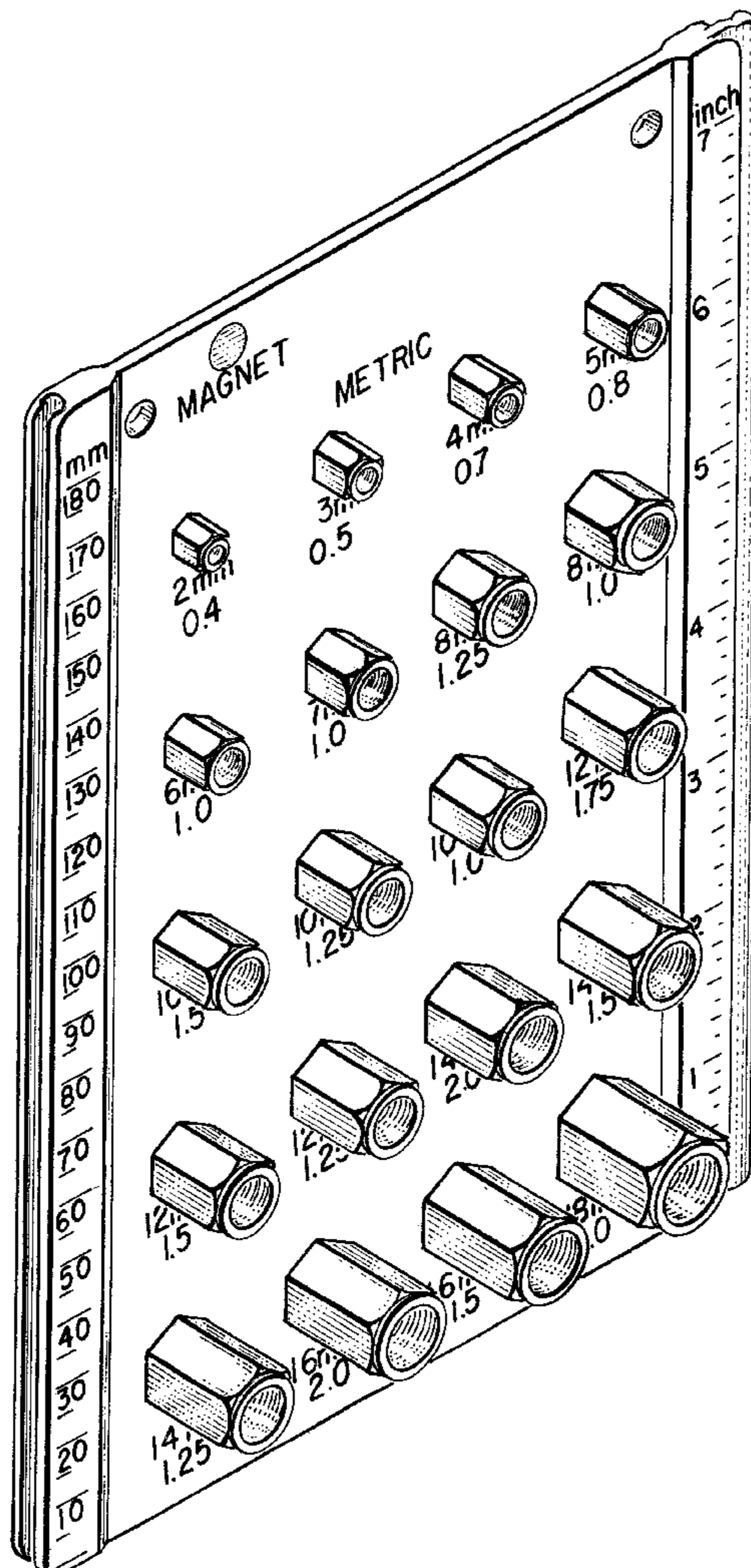

*Fig 1*

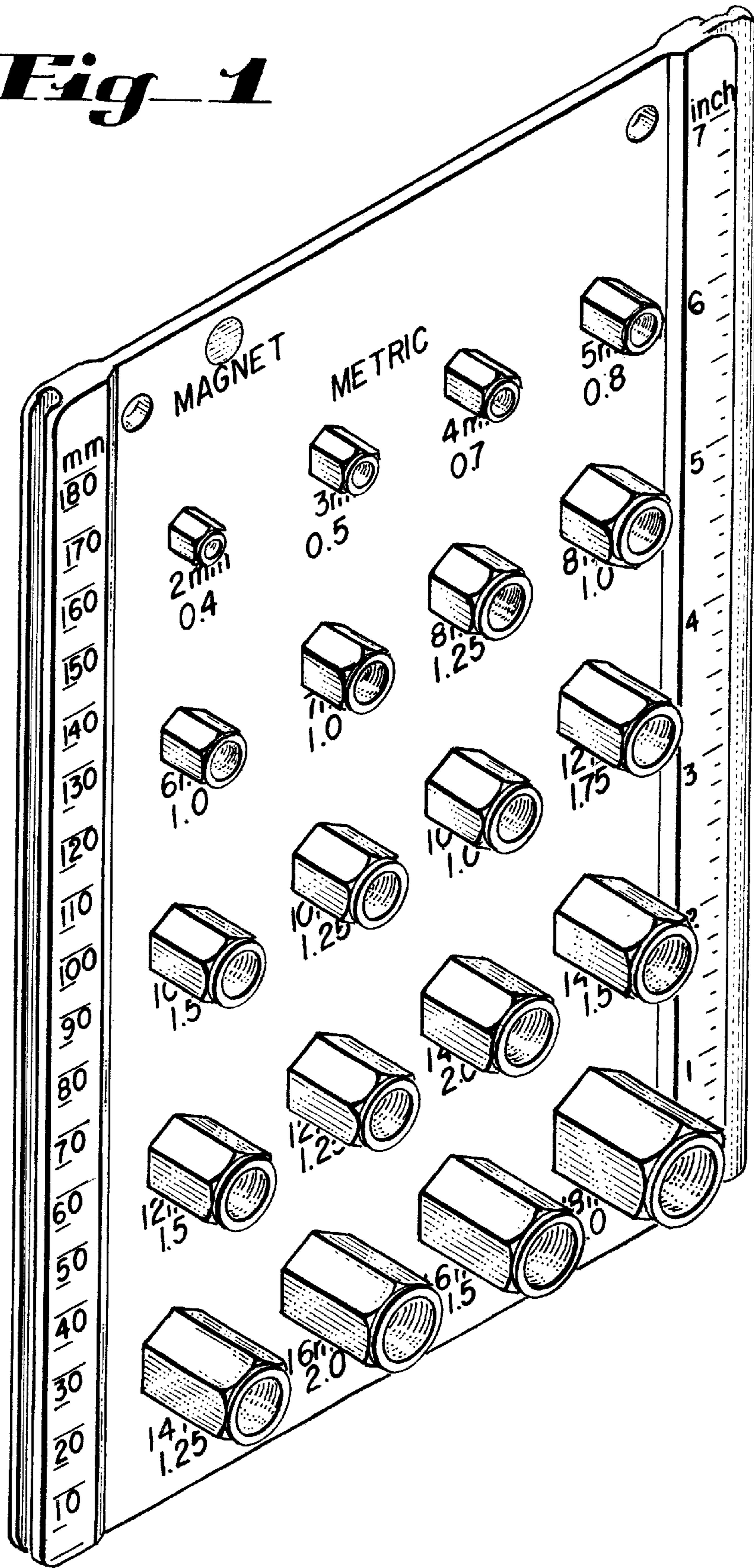

*Fig 3*

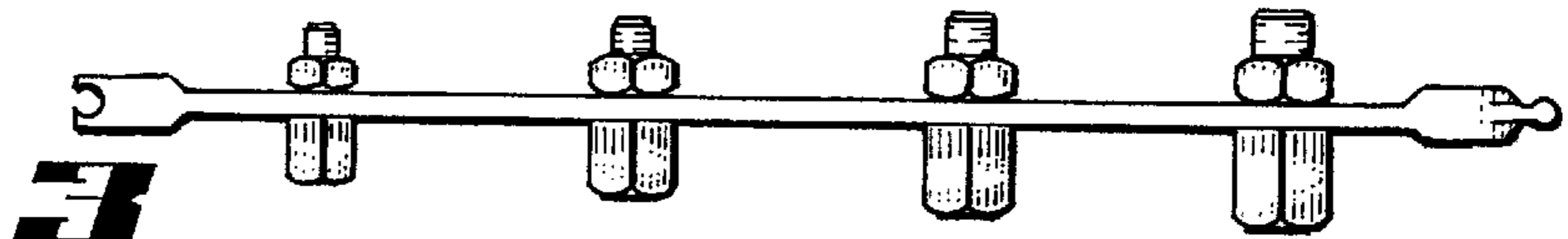

*Fig 4*

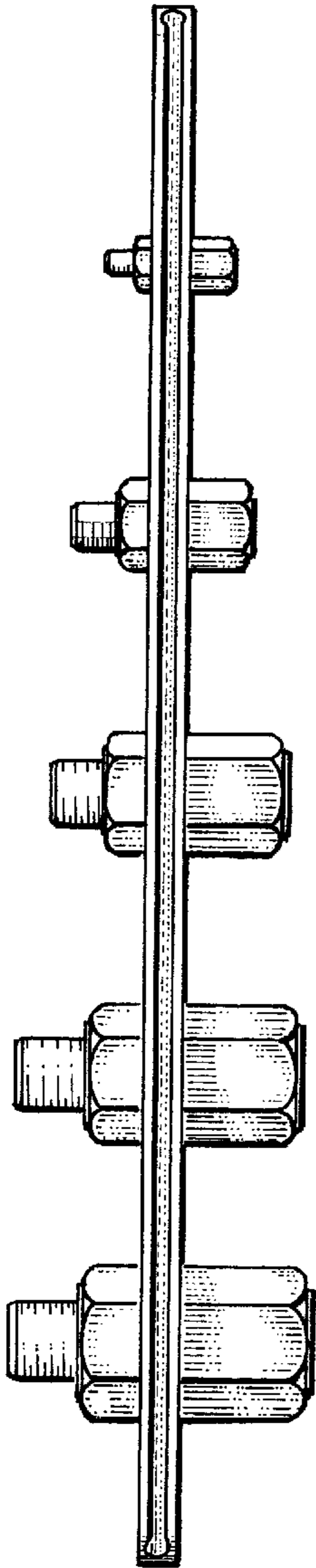

*Fig 2*

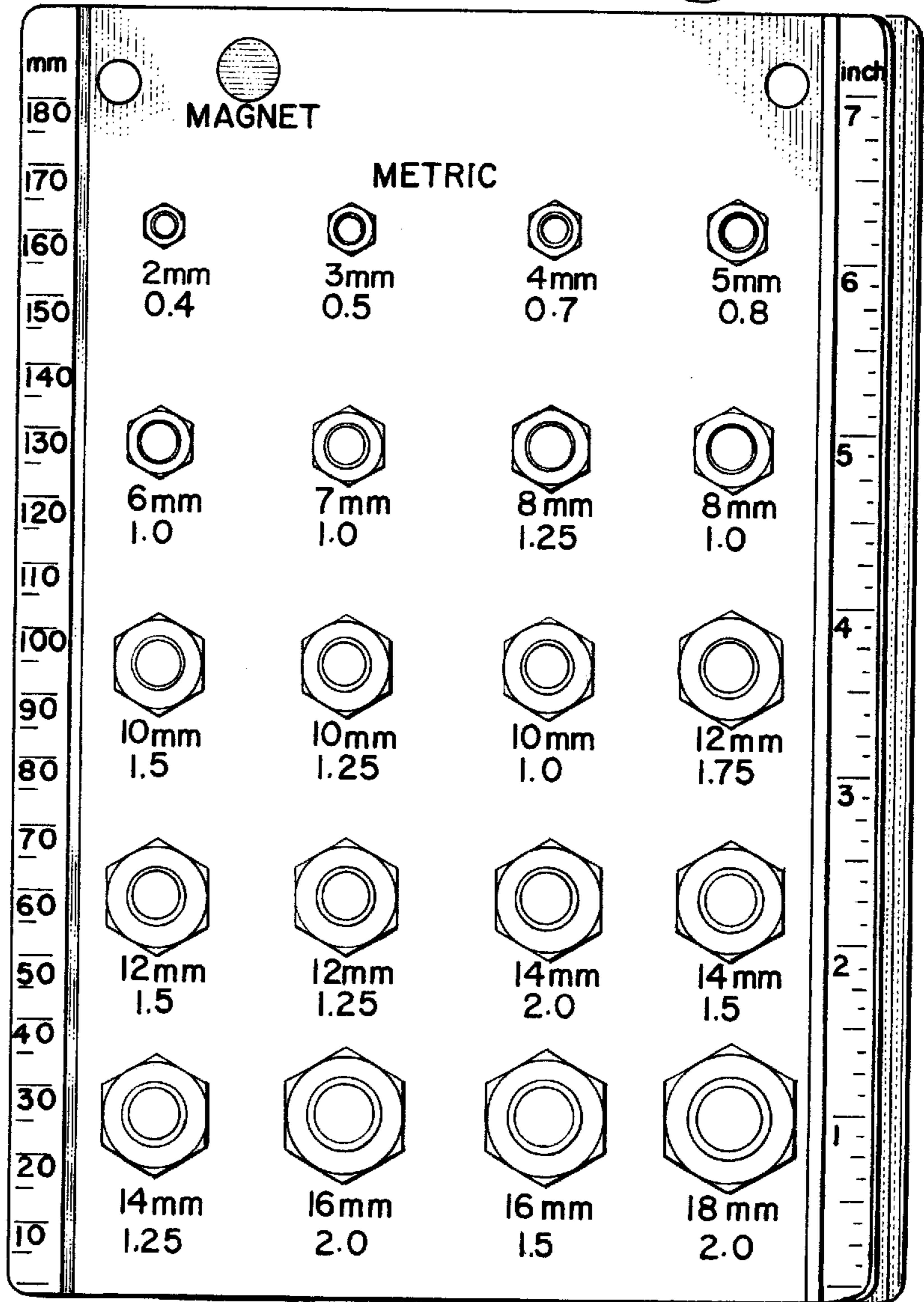

*Fig 5*

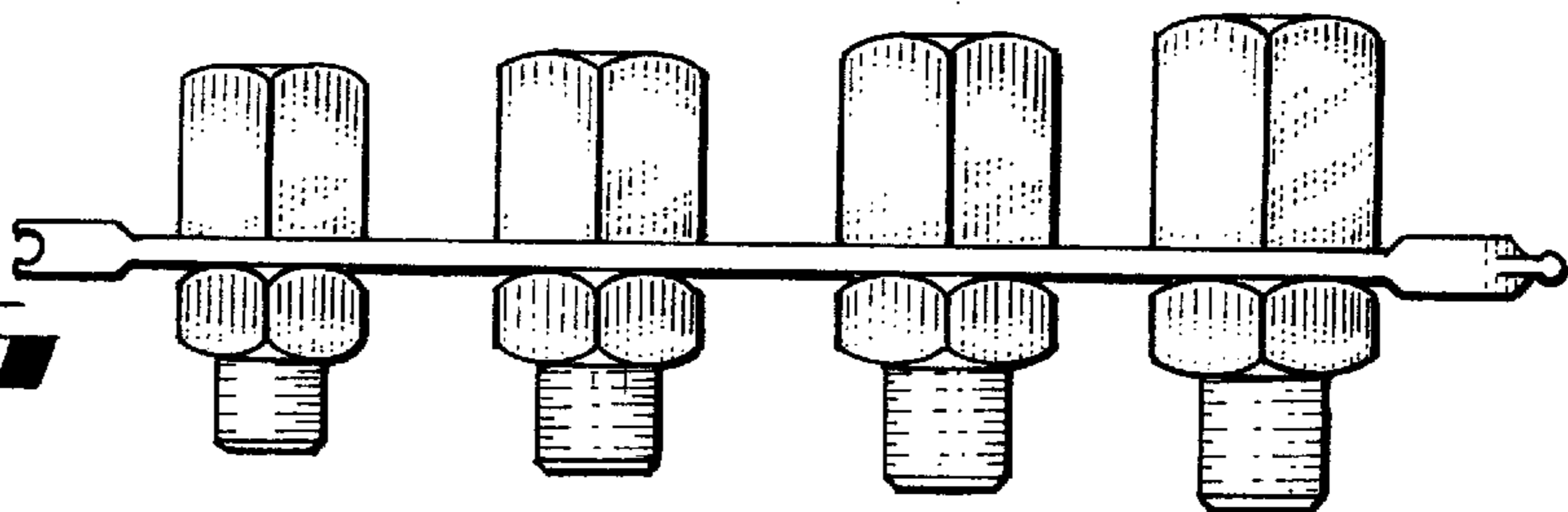

*Fig 5*

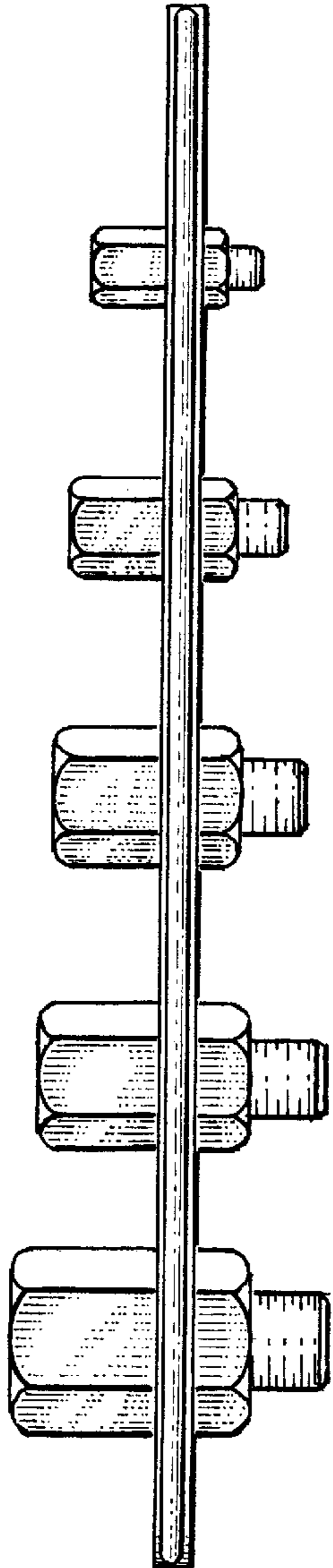

*Fig 7*

