



US00D454318S

(12) **United States Design Patent**
Schroeder et al.

(10) **Patent No.:** **US D454,318 S**

(45) **Date of Patent:** **** Mar. 12, 2002**

(54) **MOTORCYCLE FRAME**

4,887,687 A * 12/1989 Asai et al. 180/219
5,913,529 A * 6/1999 Patterson 280/281.1

(75) Inventors: **Anthony Schroeder**, Huntington Beach; **Ramon Meneses**, Redondo Beach, both of CA (US)

* cited by examiner

(73) Assignee: **Honda Giken Kogyo Kabushiki Kaisha**, Tokyo (JP)

Primary Examiner—Alan P. Douglas

Assistant Examiner—Linda Brooks

(74) *Attorney, Agent, or Firm*—Banner & Witcoff, Ltd.

(**) Term: **14 Years**

(57) **CLAIM**

(21) Appl. No.: **29/144,418**

The ornamental design for a motorcycle frame, as shown and described.

(22) Filed: **Jul. 3, 2001**

DESCRIPTION

(51) **LOC (7) Cl.** **12-11**

(52) **U.S. Cl.** **D12/110**

(58) **Field of Search** D12/110, 111, D12/114; 280/281.1, 288.1–288.4, 283, 284; 180/219

FIG. 1 is a front perspective view of a motorcycle frame showing our new design;

FIG. 2 is a rear perspective view thereof;

FIG. 3 is an elevational view of one side thereof, the other side being a mirror image thereof;

FIG. 4 is a rear view thereof; and,

FIG. 5 is a bottom plan view thereof.

(56) **References Cited**

U.S. PATENT DOCUMENTS

4,585,086 A * 4/1986 Hiramatsu 180/219

1 Claim, 2 Drawing Sheets

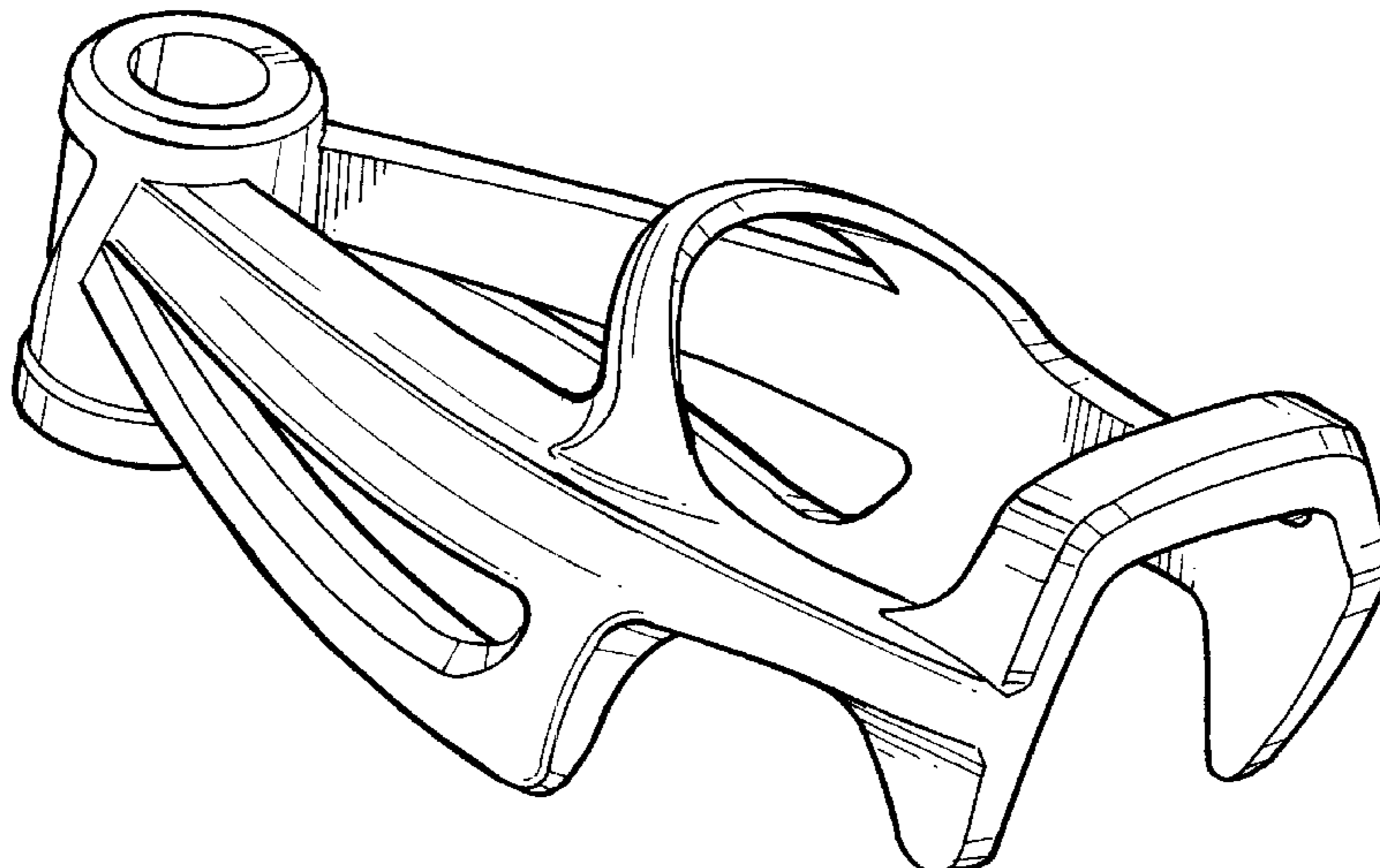
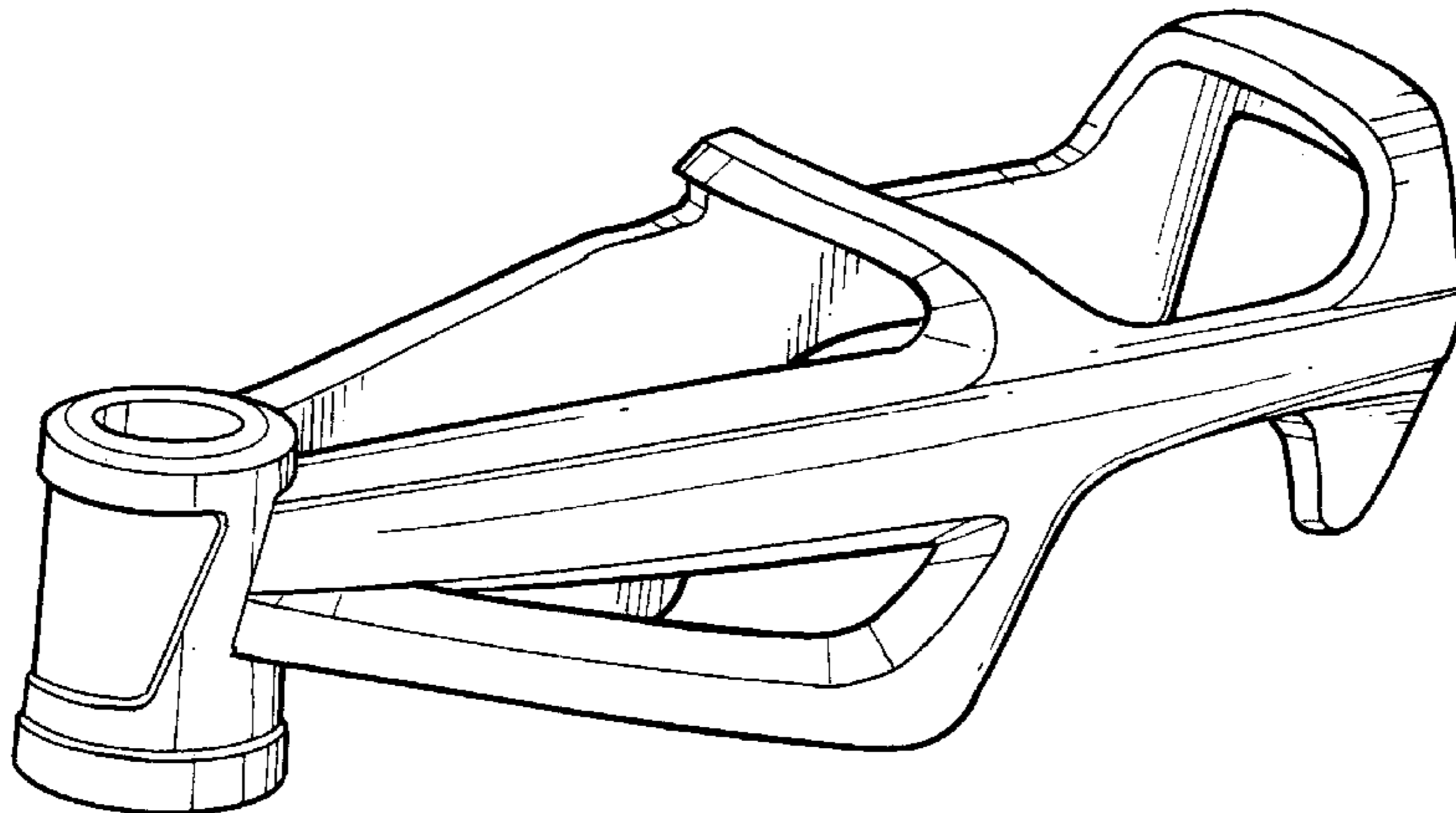

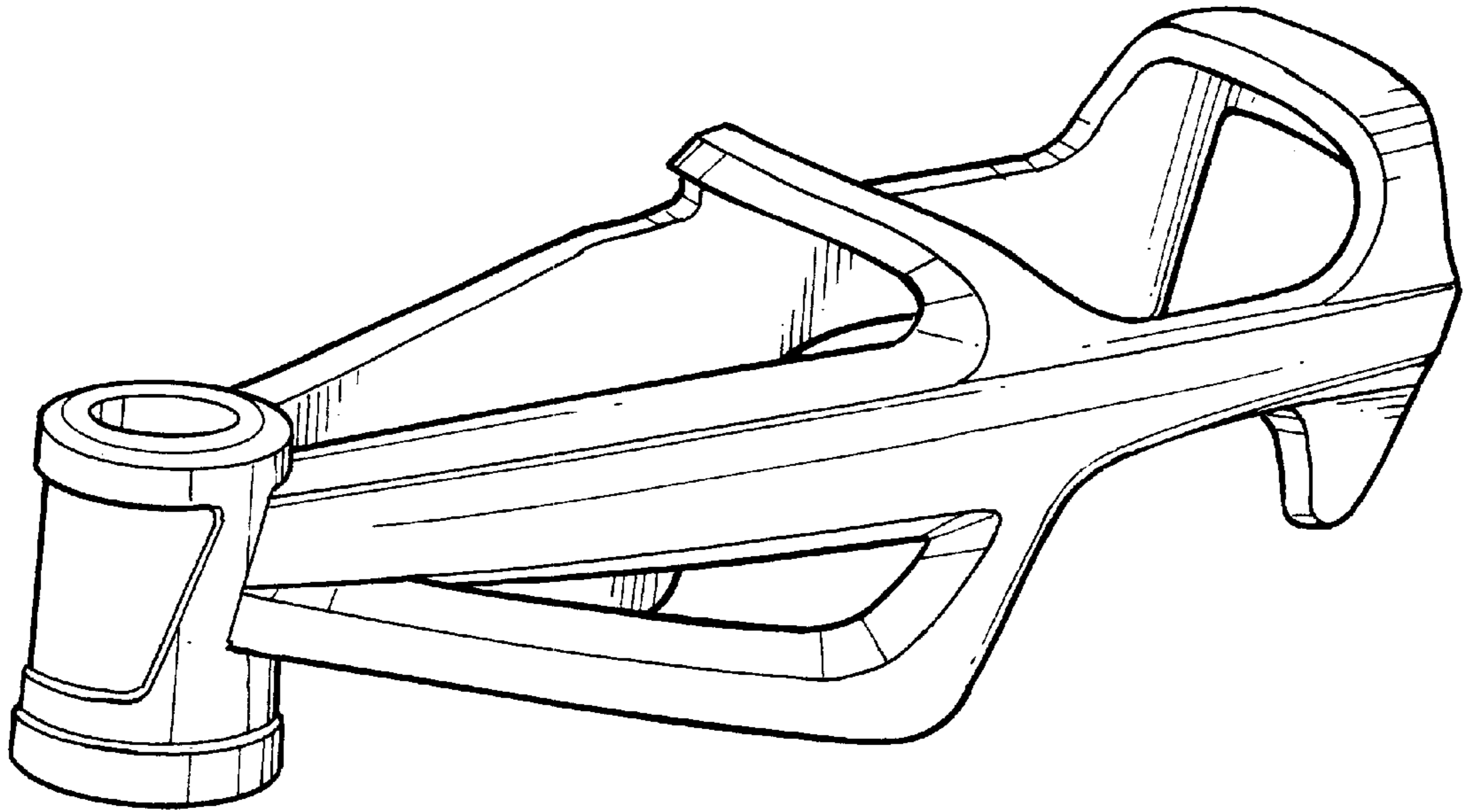

FIG. 1

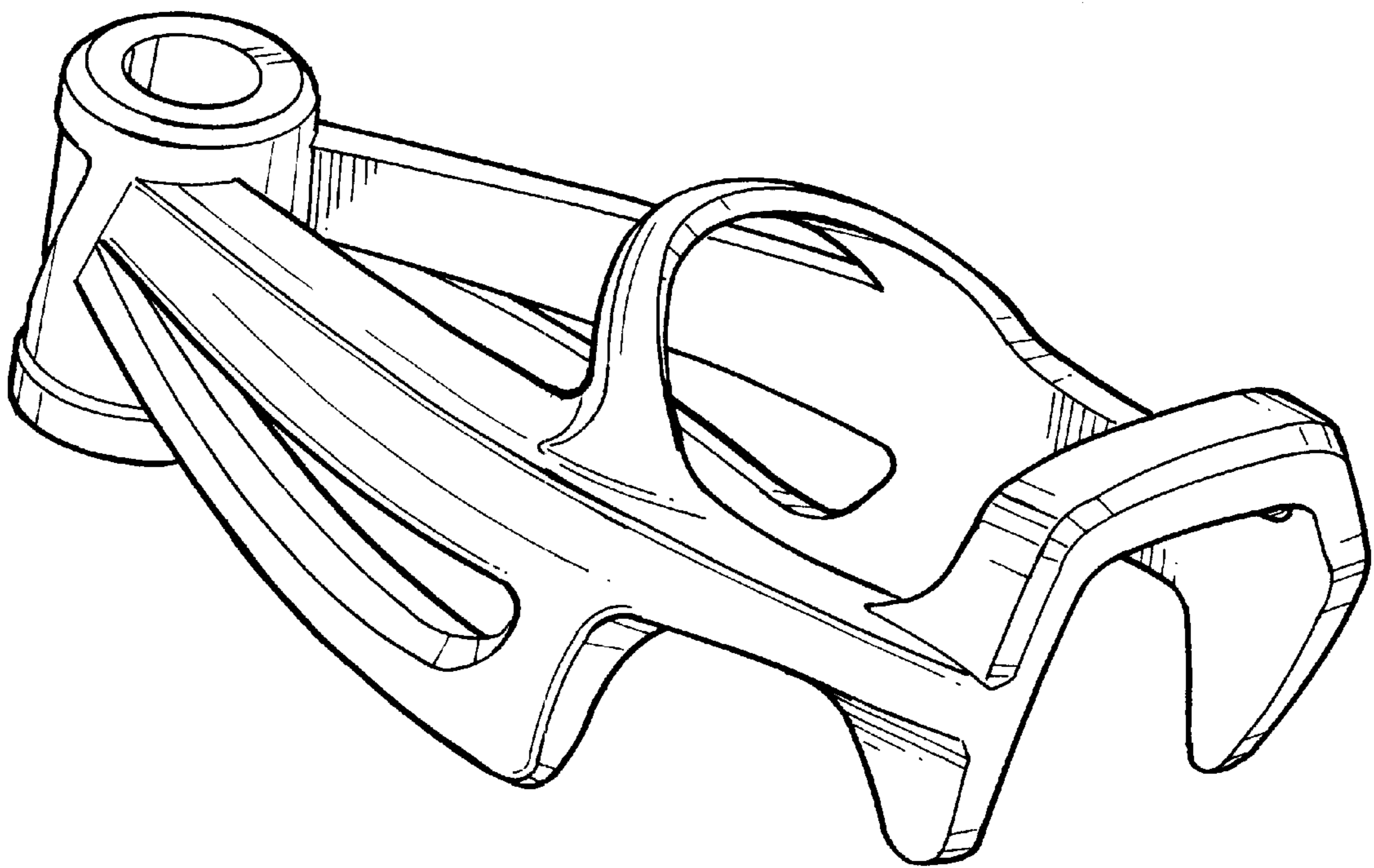

FIG. 2

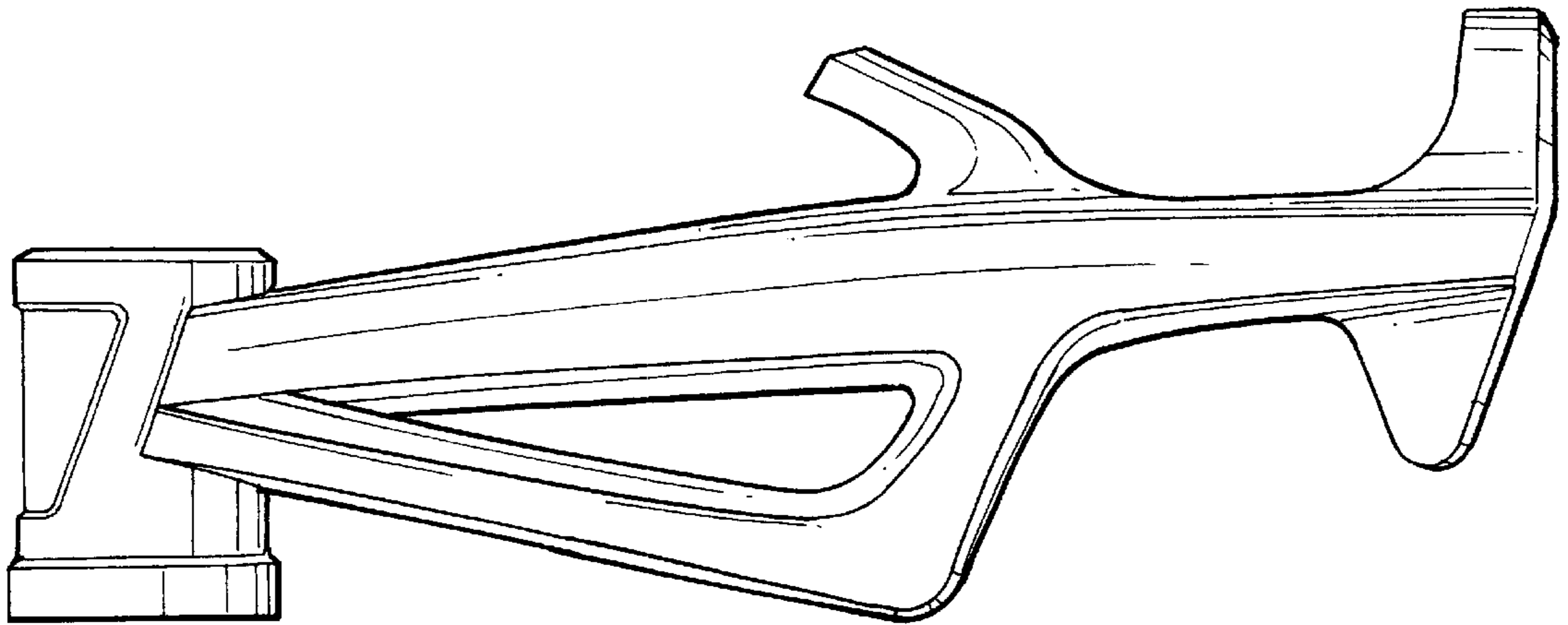

FIG. 3

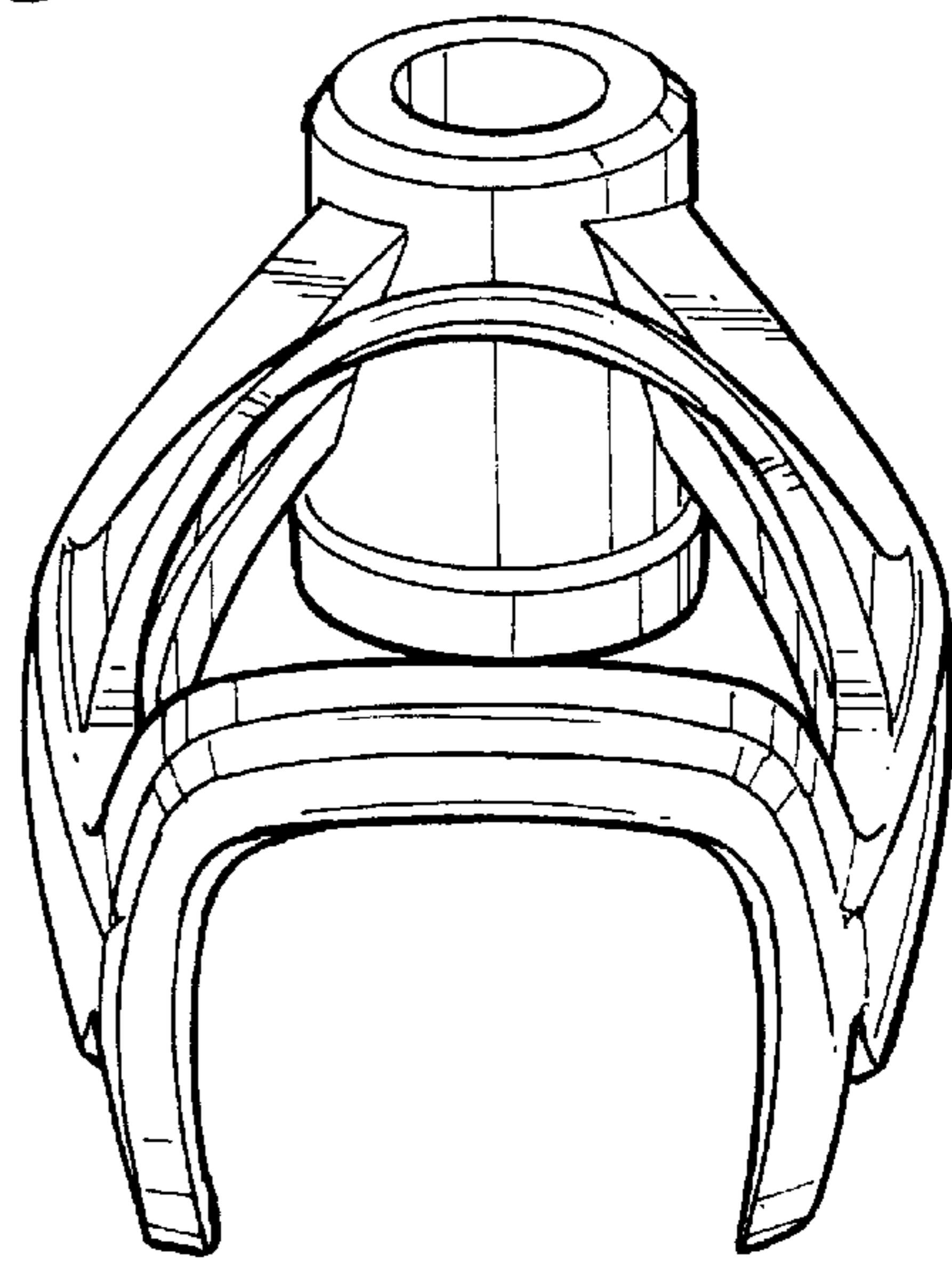

FIG. 4

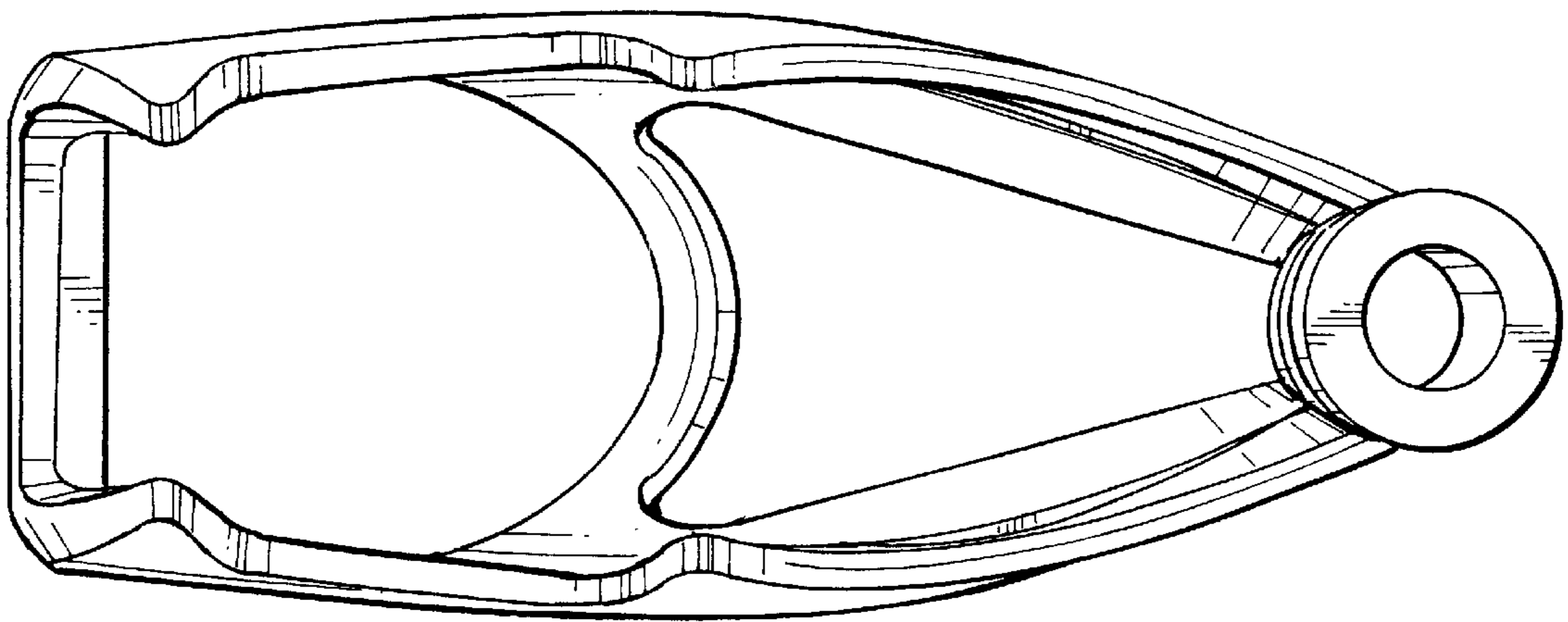

FIG. 5