



US00D454292S

(12) **United States Design Patent** (10) **Patent No.:** **US D454,292 S**
Plummer et al. (45) **Date of Patent:** **** Mar. 12, 2002**

(54) **FLEXIBLE DRAW LATCH**

(75) Inventors: **Richard M. Plummer**, Kennett Square, PA (US); **Andres A. Bolinas**, Claymont, DE (US)

(73) Assignee: **Southco**, Concordville, PA (US)

(**) Term: **14 Years**

(21) Appl. No.: **29/122,390**

(22) Filed: **Apr. 23, 2000**

(51) **LOC (7) Cl.** **08-07**

(52) **U.S. Cl.** **D8/331**

(58) **Field of Search** D8/330, 331, 313, D8/336-338, 342; 16/446; 292/336.3, DIG. 16, 11, 12, 262, 268, 269, 270, 281

(56) **References Cited**

U.S. PATENT DOCUMENTS

4,804,215	A	2/1989	Bisbing	
4,828,298	A	5/1989	Bisbing	
D324,165	S	2/1992	Bressler et al.	
D333,775	S	* 3/1993	Krape D8/331 X
D435,780	S	* 1/2001	Tieu D8/331

OTHER PUBLICATIONS

Flexible Latches, No. RHF2, Eberhard Hardware, Dec. 1986.*
Series 101, Southco, HH-2.*

“Southco Handbook 2000,” Southco, Inc., 1999, pp. 186-192.

“Southco Fasteners Handbook 35,” Southco, Inc., 1986, pp. HH-2 to HH-7.

* cited by examiner

Primary Examiner—Jennifer Rivard

(74) *Attorney, Agent, or Firm*—Paul & Paul

(57) **CLAIM**

The ornamental design for a flexible draw latch, as shown and described.

DESCRIPTION

FIG. 1 is a perspective view of an embodiment of a flexible draw latch embodying the new design;

FIG. 2 is a top plan view thereof;

FIG. 3 is a bottom plan view thereof;

FIG. 4 is a right side elevational view thereof, the left side elevational view being a mirror image of the right side;

FIG. 5 is a front elevational view thereof; and,

FIG. 6 is a rear elevational view thereof.

The portions of the flexible draw latch of the present invention shown in broken lines form no part of the claimed design.

1 Claim, 3 Drawing Sheets

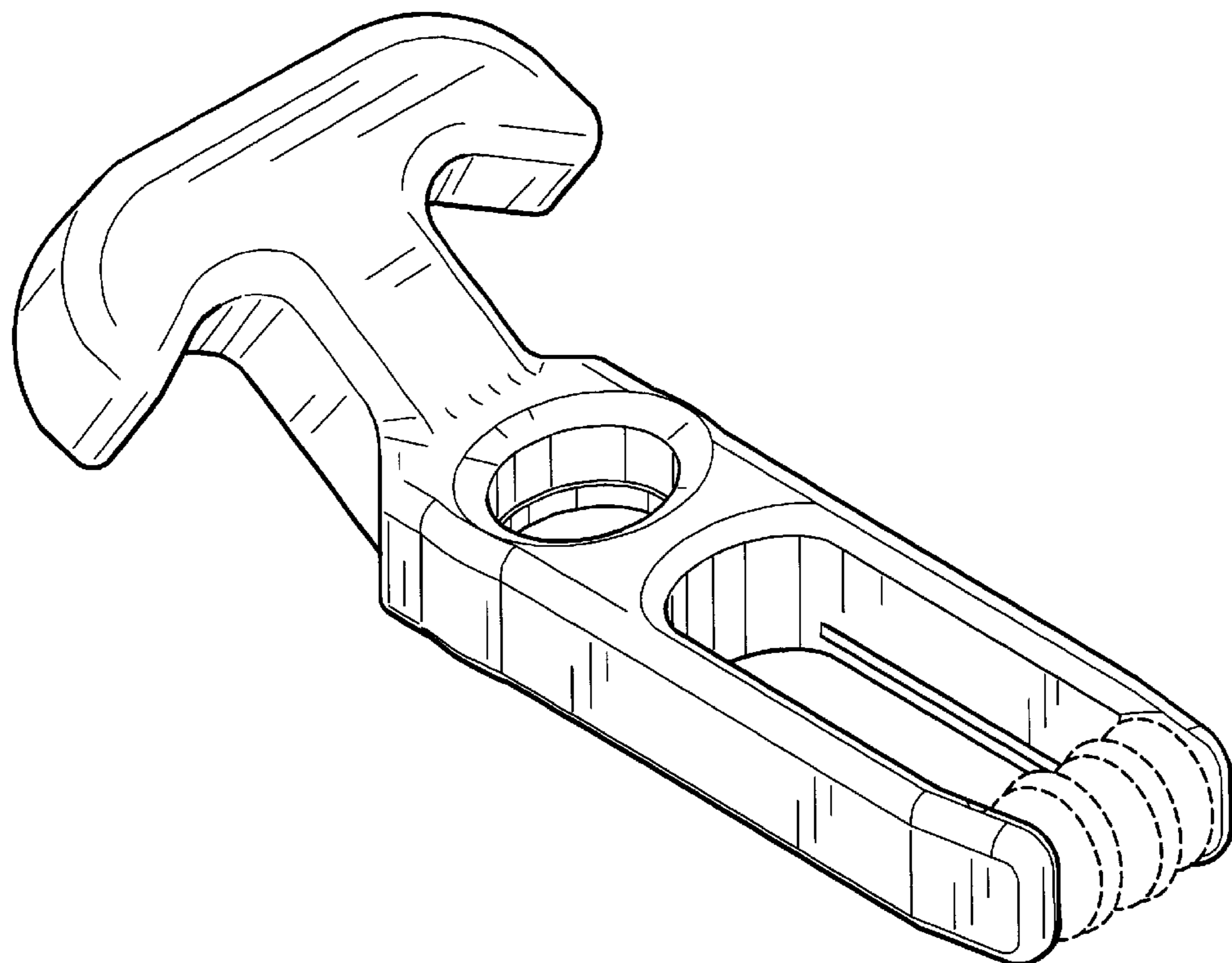

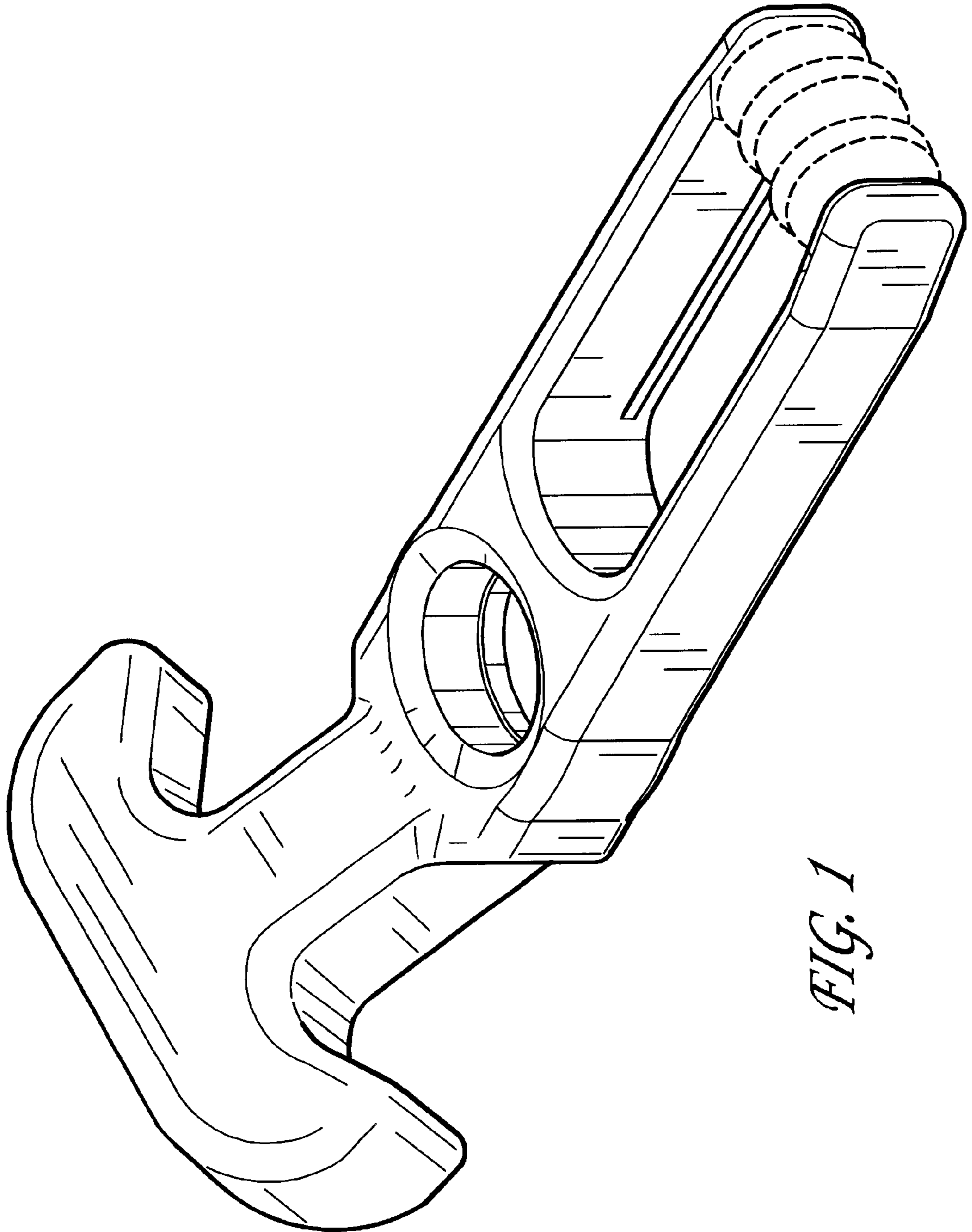

FIG. 1

FIG. 2

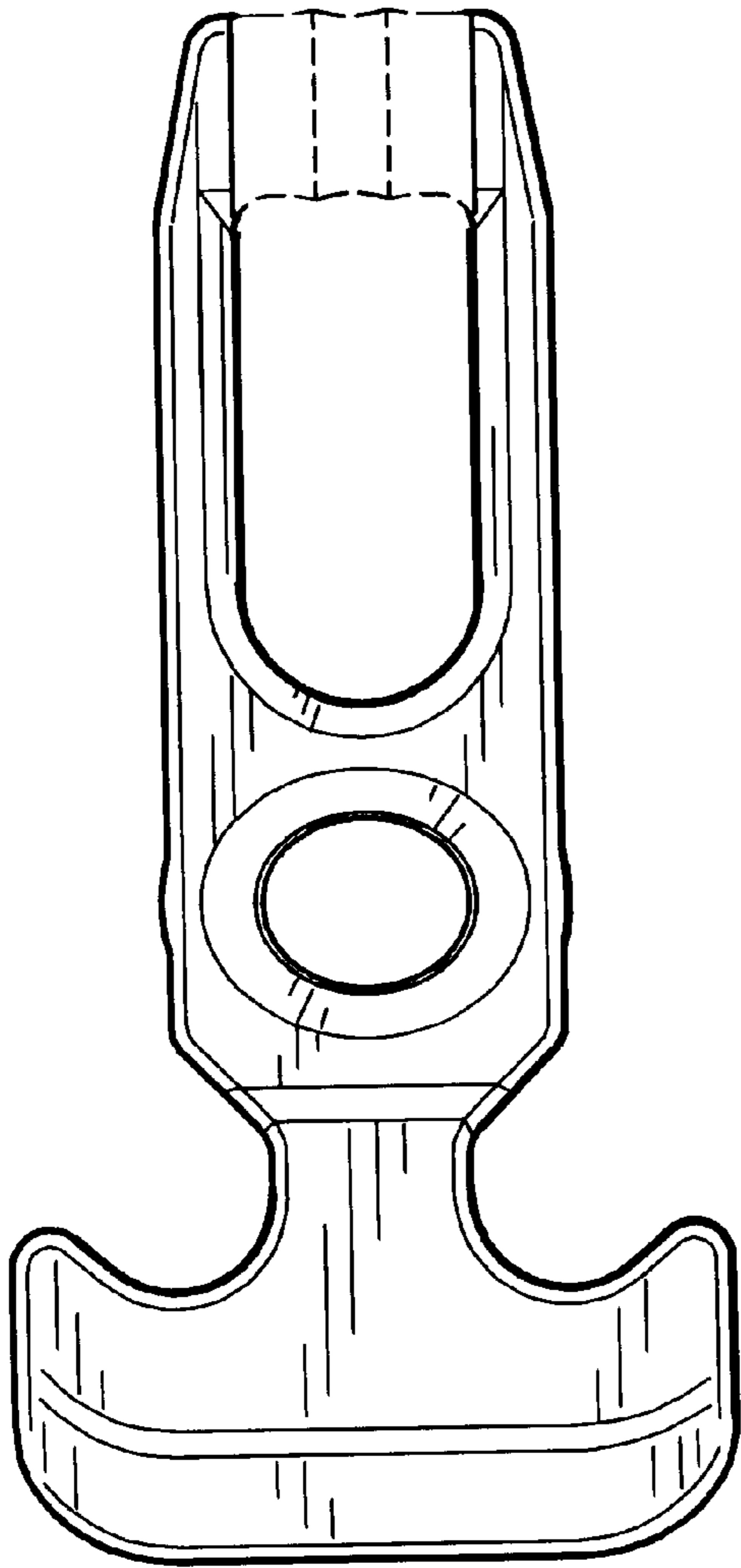
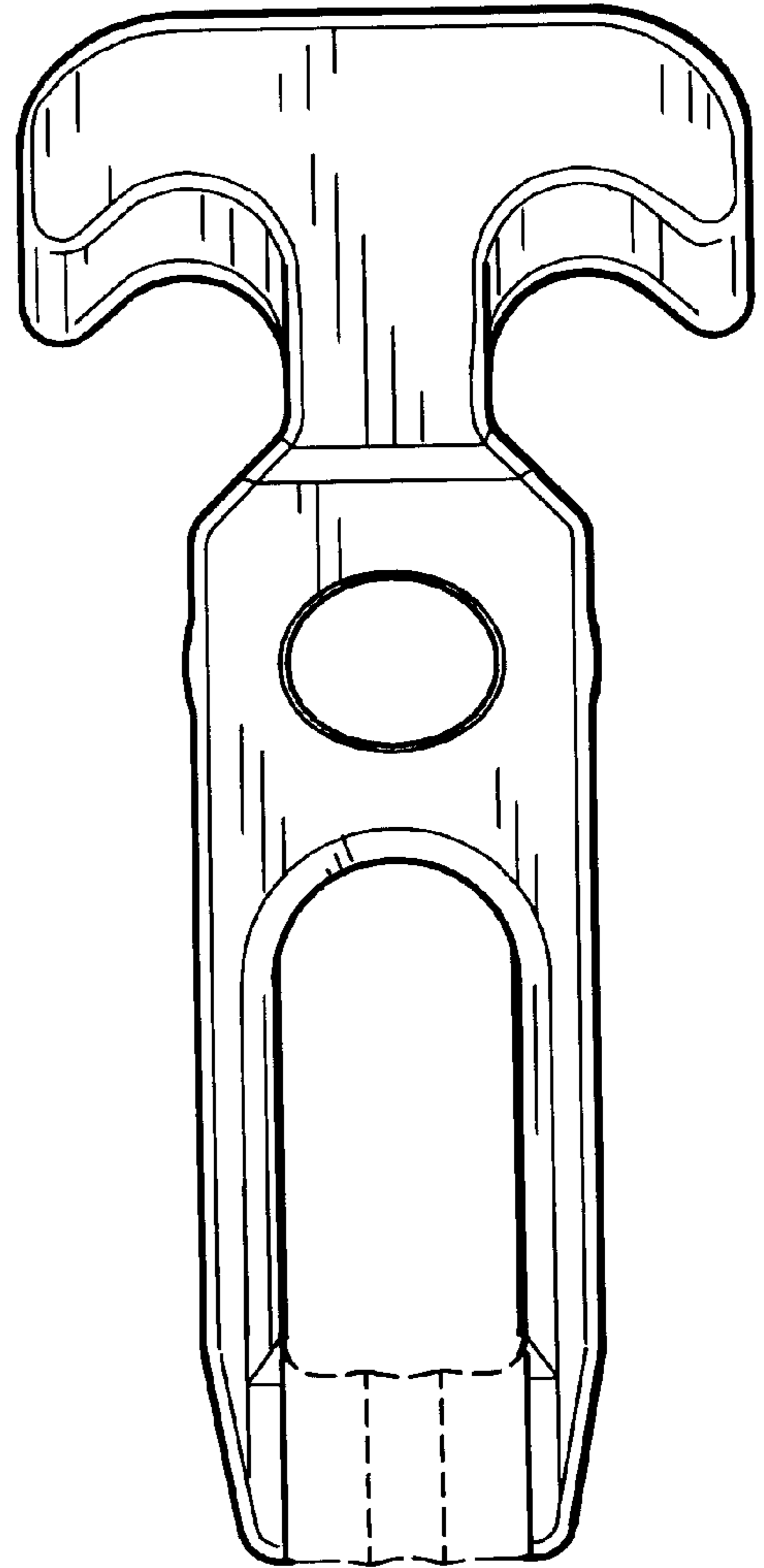

FIG. 3



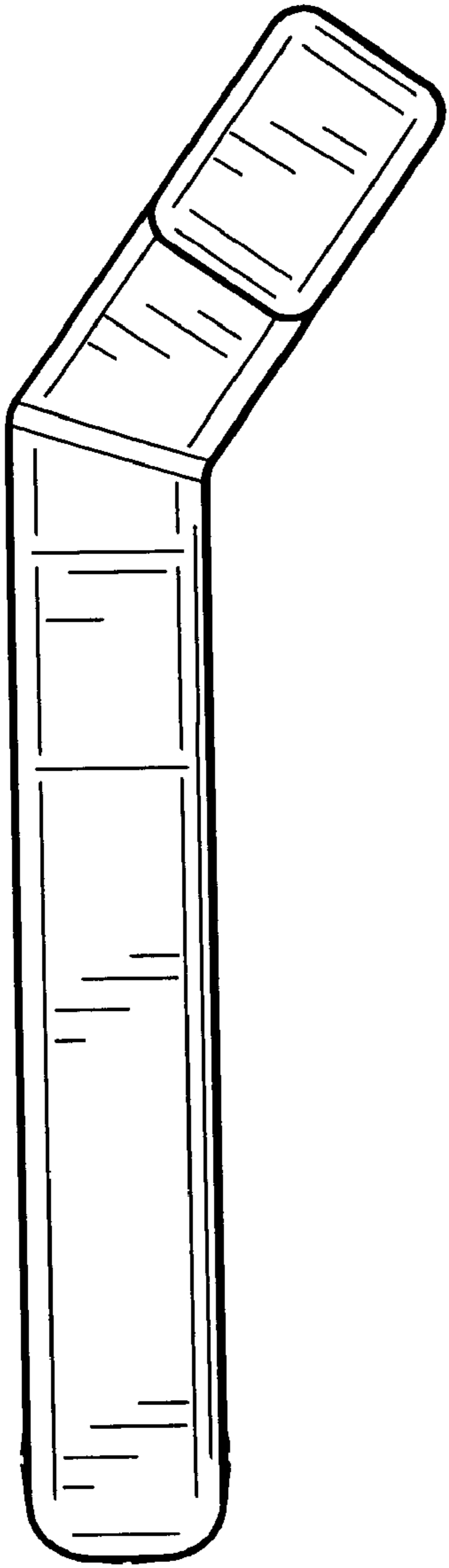

FIG. 4

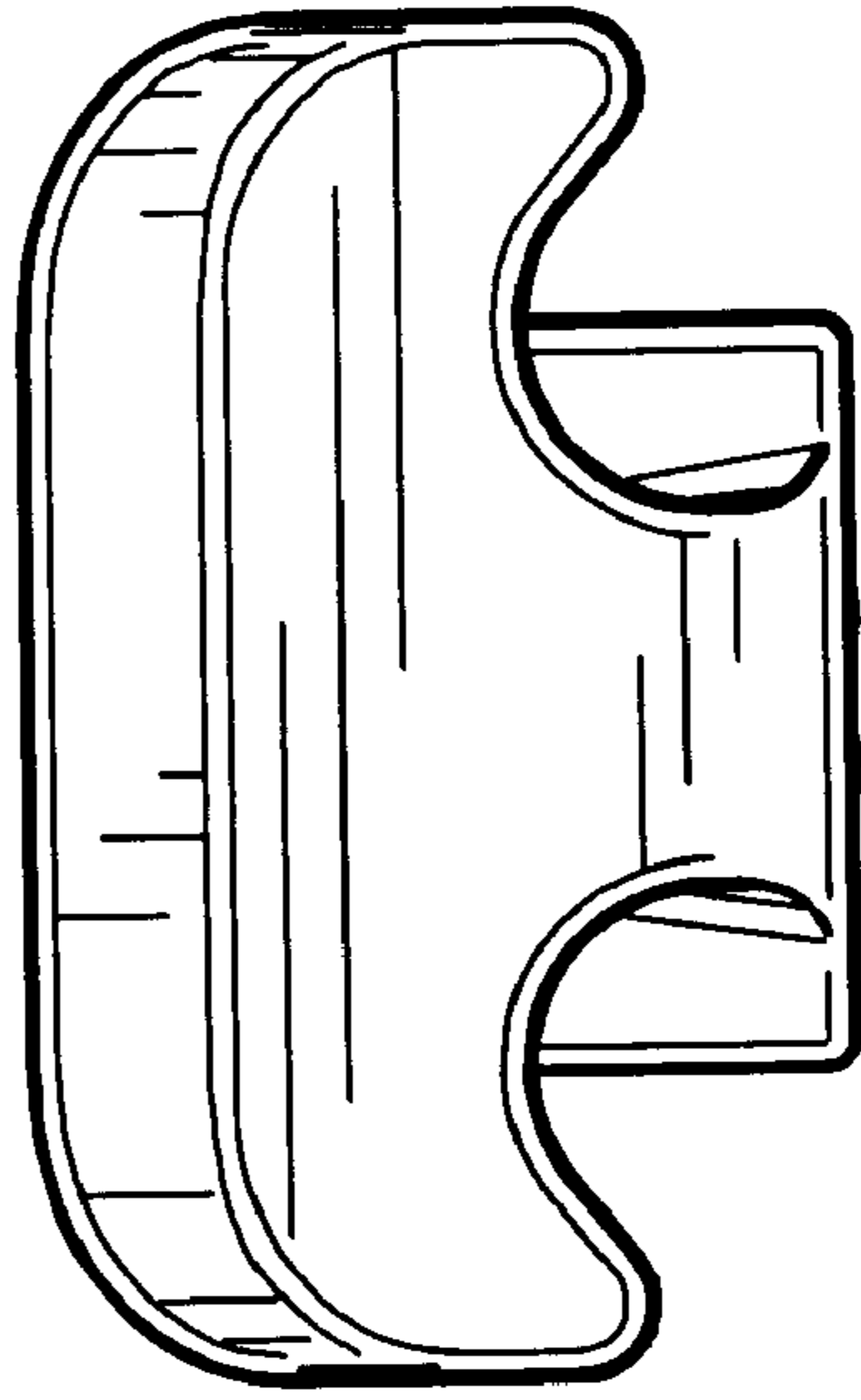

FIG. 6

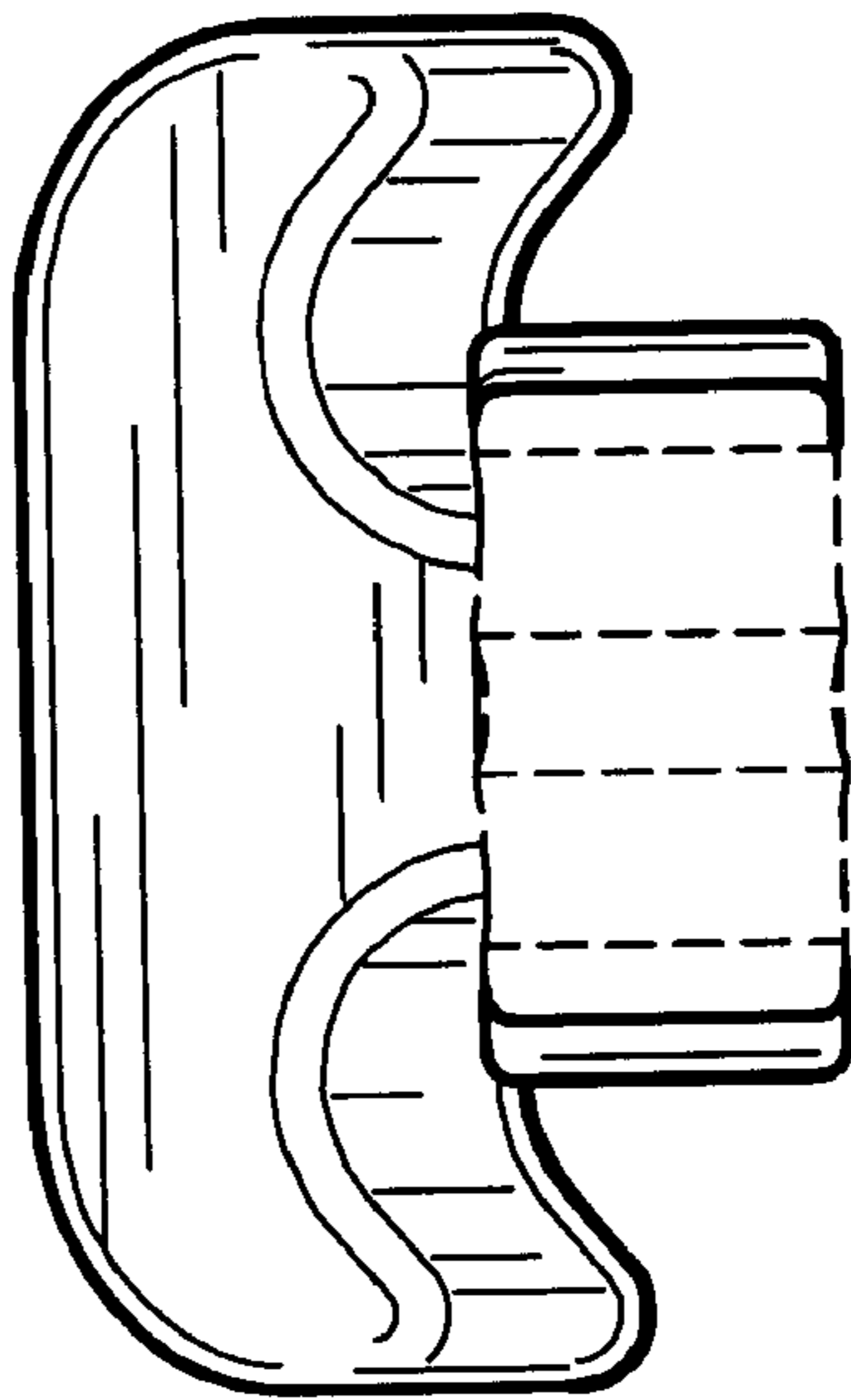

FIG. 5