



US00D454109S

(12) **United States Design Patent**
Moshier

(10) **Patent No.:** **US D454,109 S**

(45) **Date of Patent:** **** Mar. 5, 2002**

(54) **AIRCRAFT**

(75) Inventor: **Michael Moshier**, Los Altos Hills, CA (US)

(73) Assignee: **Millennium Jet, Inc.**, Los Altos Hills, CA (US)

(**) Term: **14 Years**

(21) Appl. No.: **29/117,335**

(22) Filed: **Jan. 20, 2000**

(51) **LOC (7) Cl.** **12-07**

(52) **U.S. Cl.** **D12/319**

(58) **Field of Search** D12/319-345;
244/13, 37, 36, 45 A, 45 R

(56) **References Cited**

U.S. PATENT DOCUMENTS

D326,255 S * 5/1992 Graham et al. D12/331

D446,182 S * 8/2001 Adam, Jr. et al. D12/319

* cited by examiner

Primary Examiner—Marcus A. Jackson

(74) *Attorney, Agent, or Firm*—Knobbe, Martens, Olson & Bear, LLP

(57) **CLAIM**

The ornamental design for an aircraft, as shown and described.

DESCRIPTION

FIG. 1 is an isometric view of the aircraft of the present invention, shown from a vantage point to the front, the left, and above the aircraft;

FIG. 2 is a top plan view thereof;

FIG. 3 is a bottom plan view thereof;

FIG. 4 is a left side elevational view thereof;

FIG. 5 is a front elevational view thereof; and,

FIG. 6 is a rear elevational view thereof.

Phantom lining, where utilized, is for illustrative purposes only and is not intended to limit the claimed design to the features shown in phantom.

1 Claim, 6 Drawing Sheets

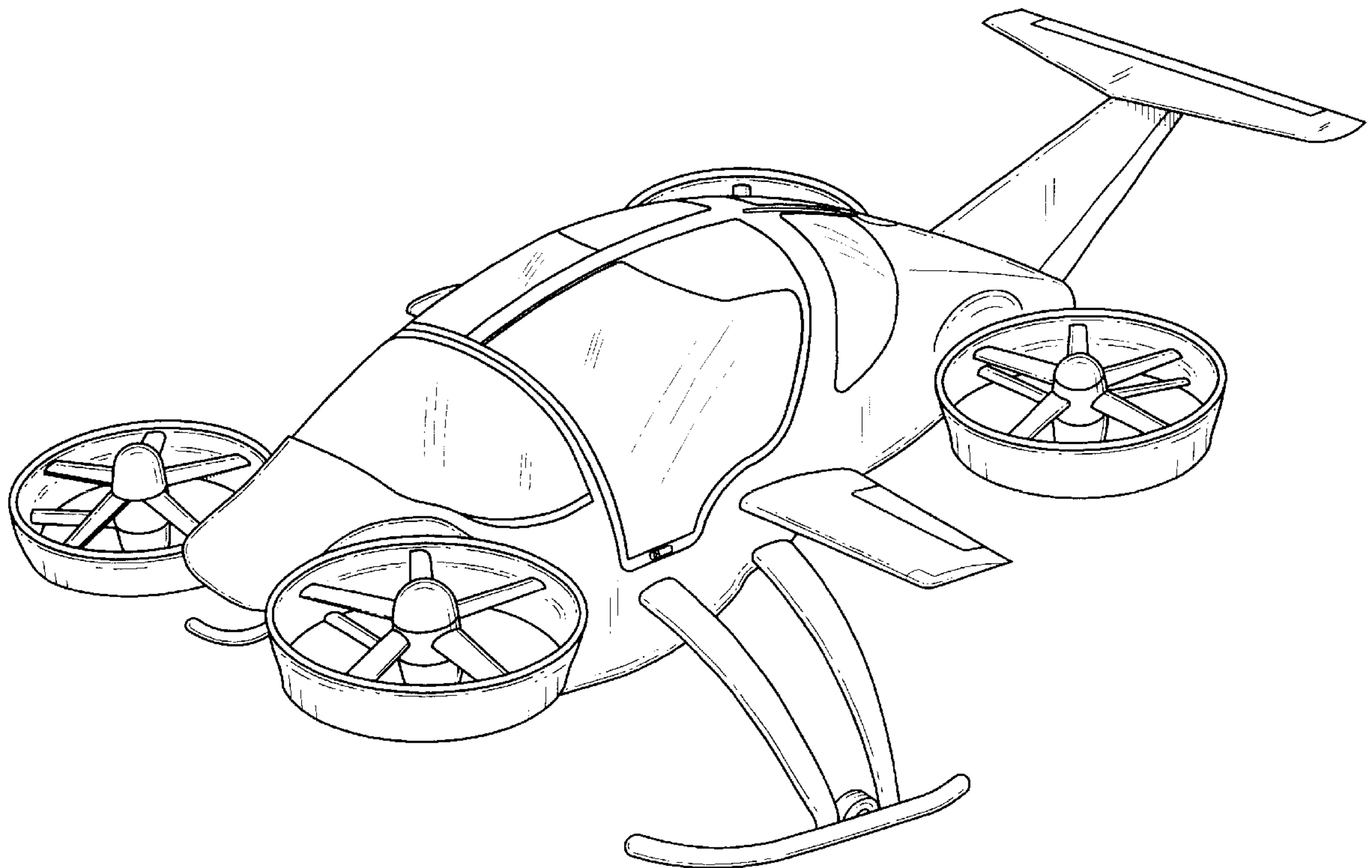

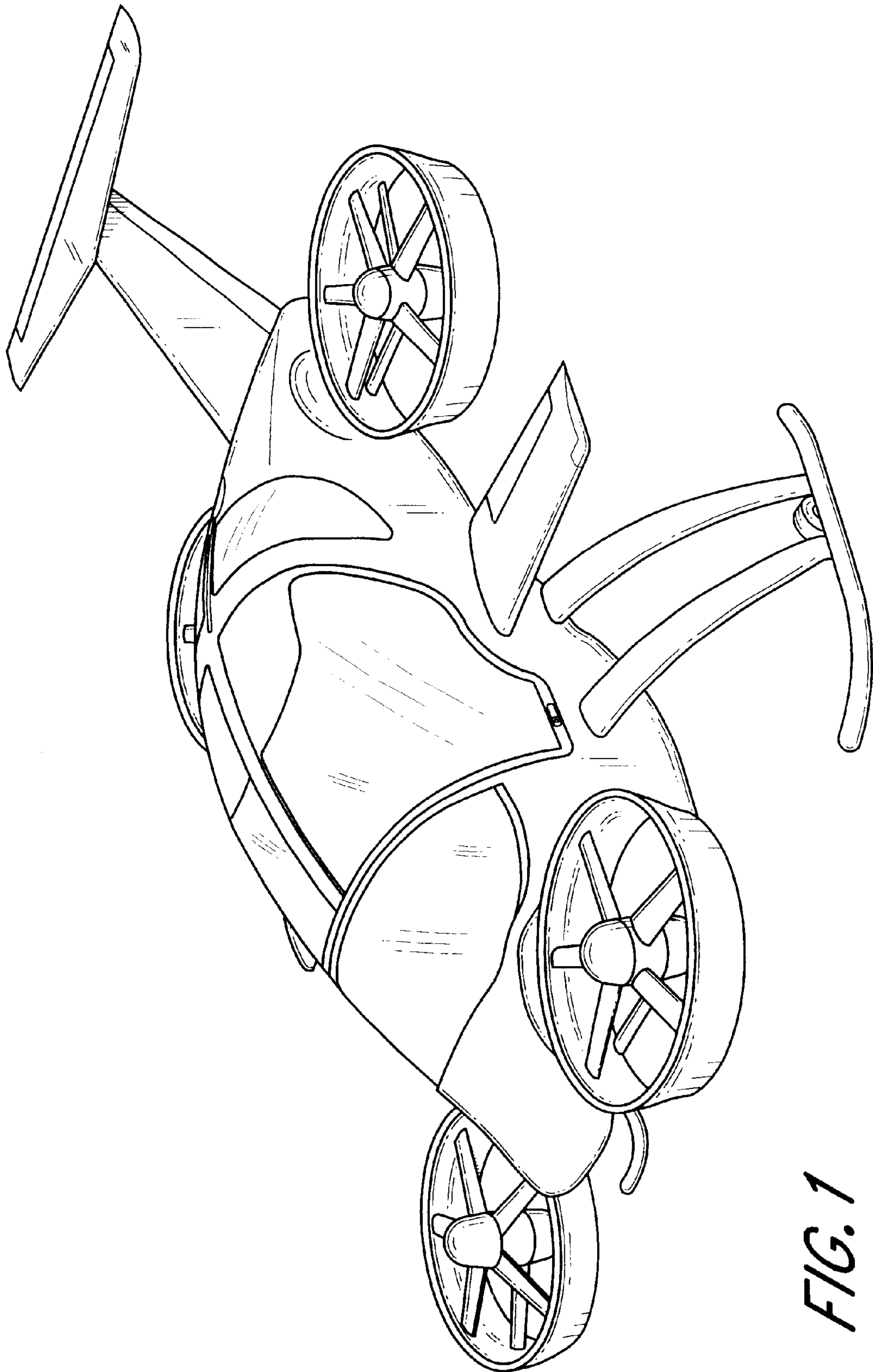

FIG. 1

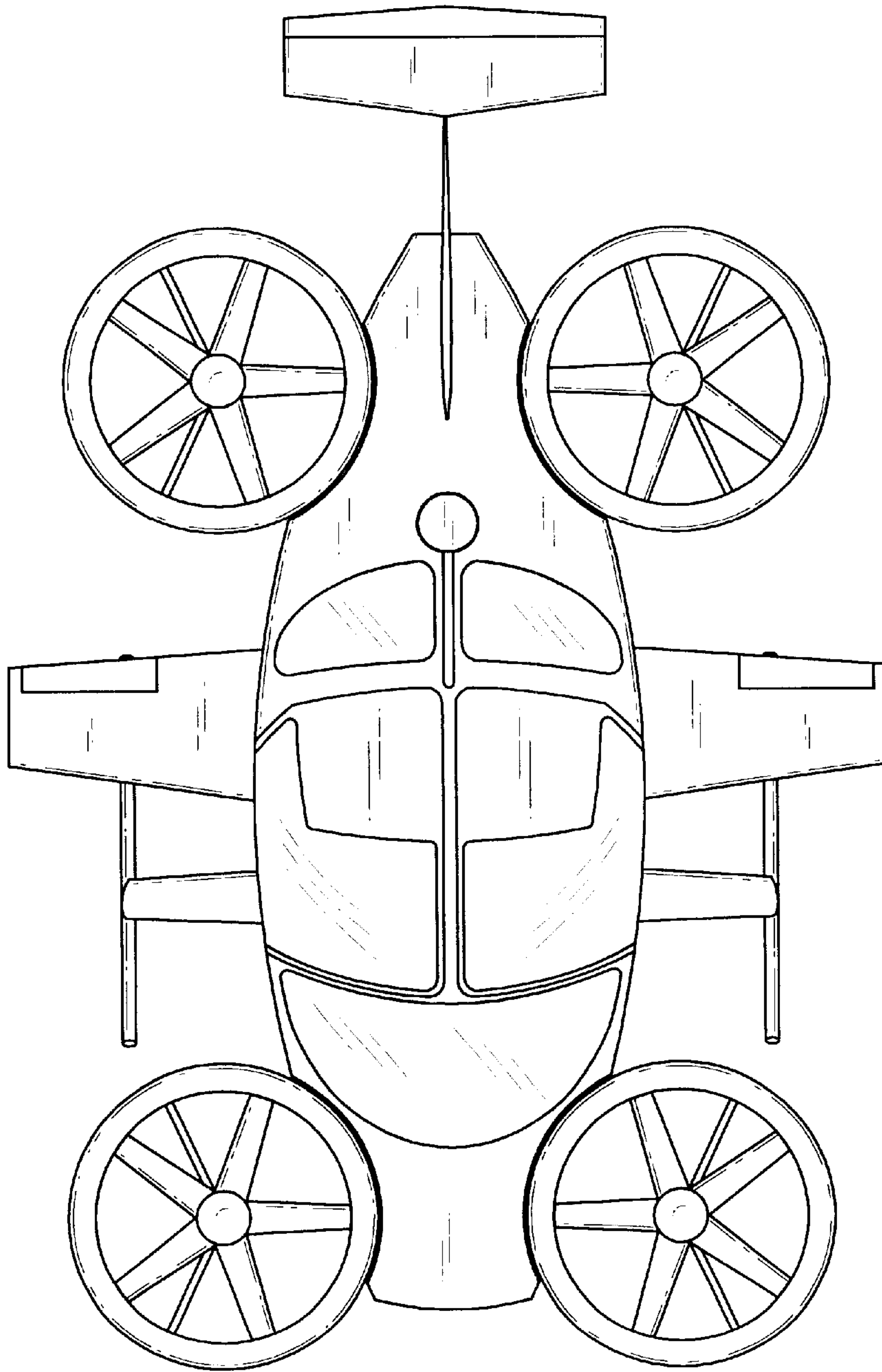

FIG. 2

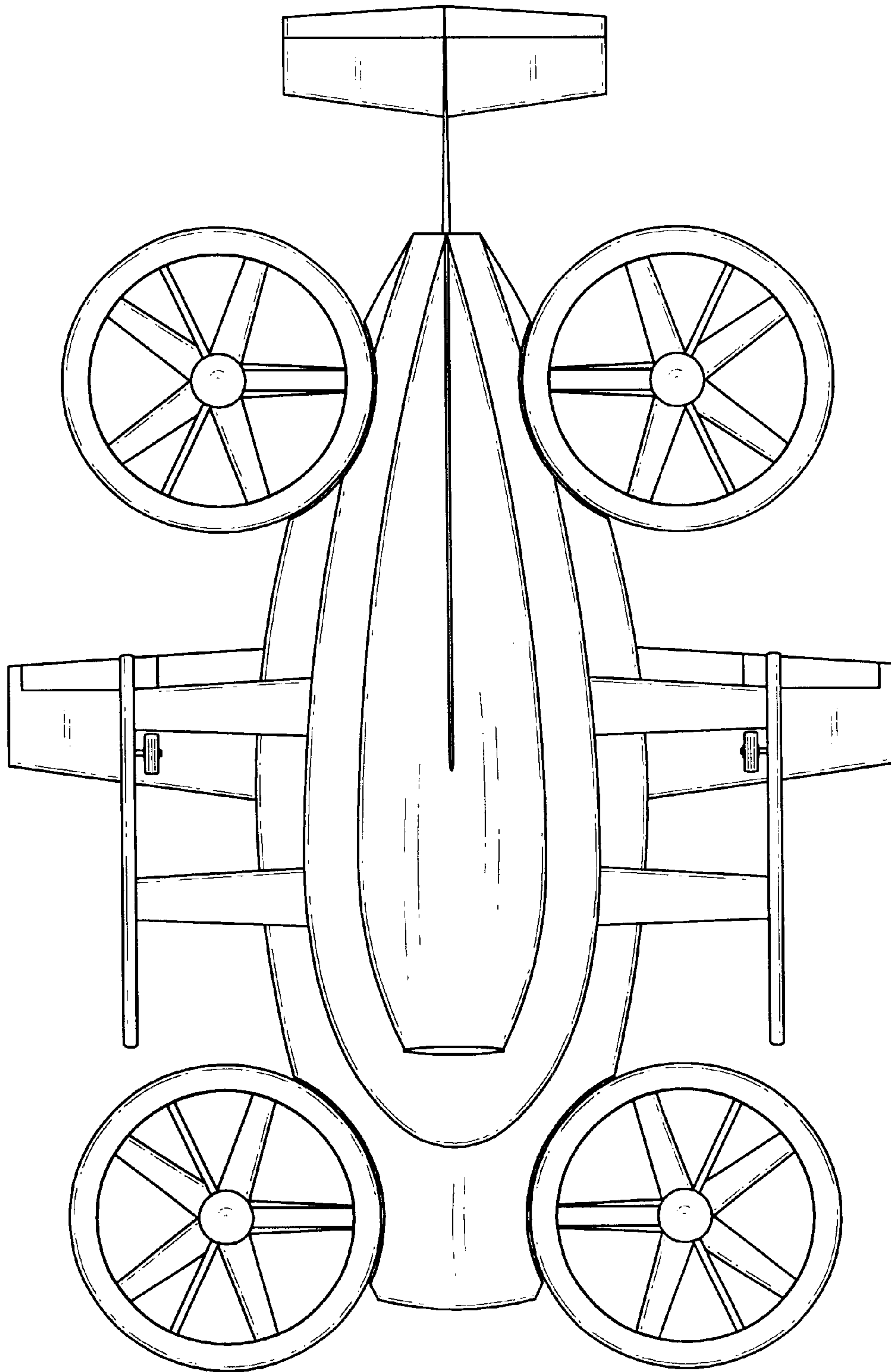

FIG. 3

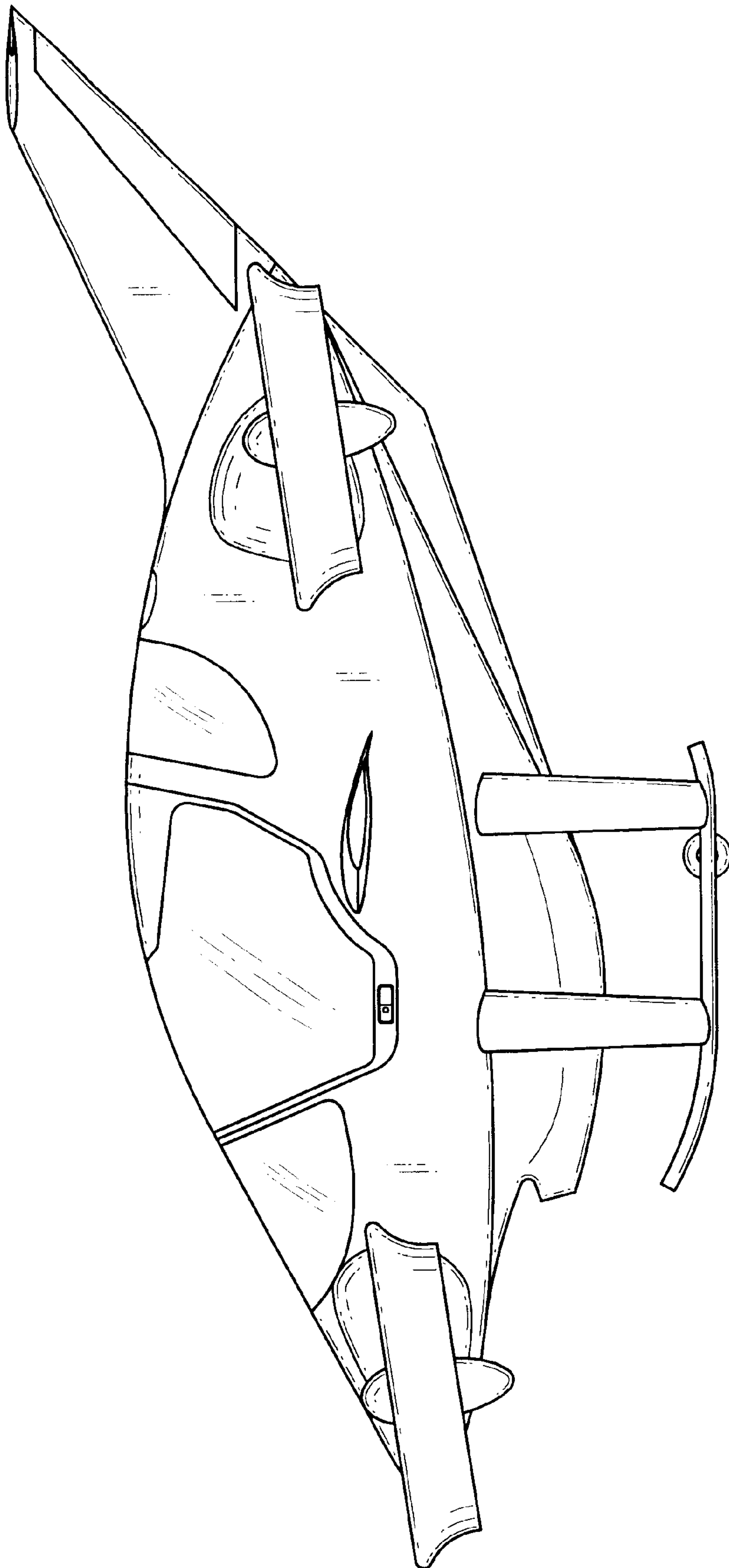

FIG. 4

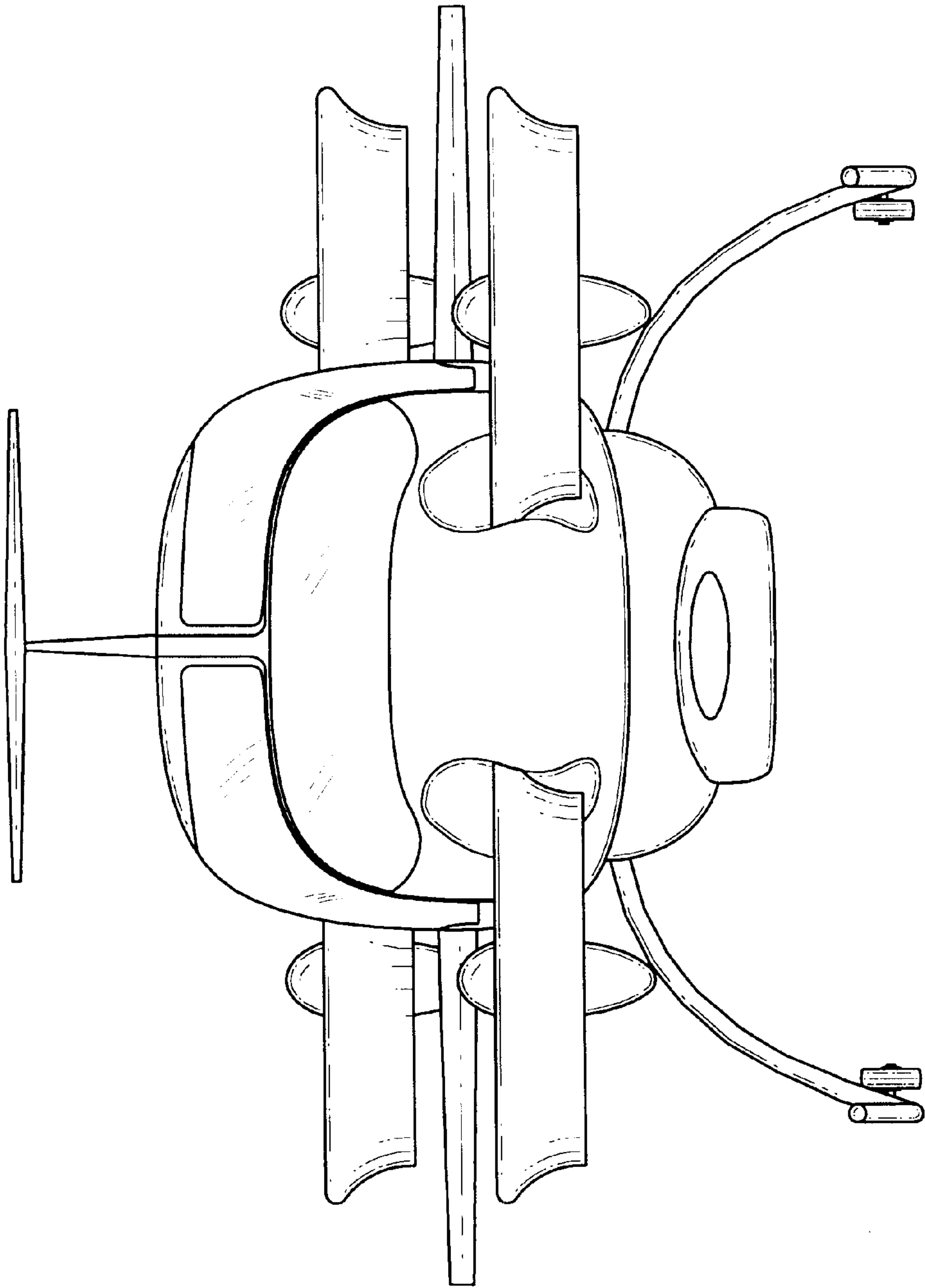

FIG. 5

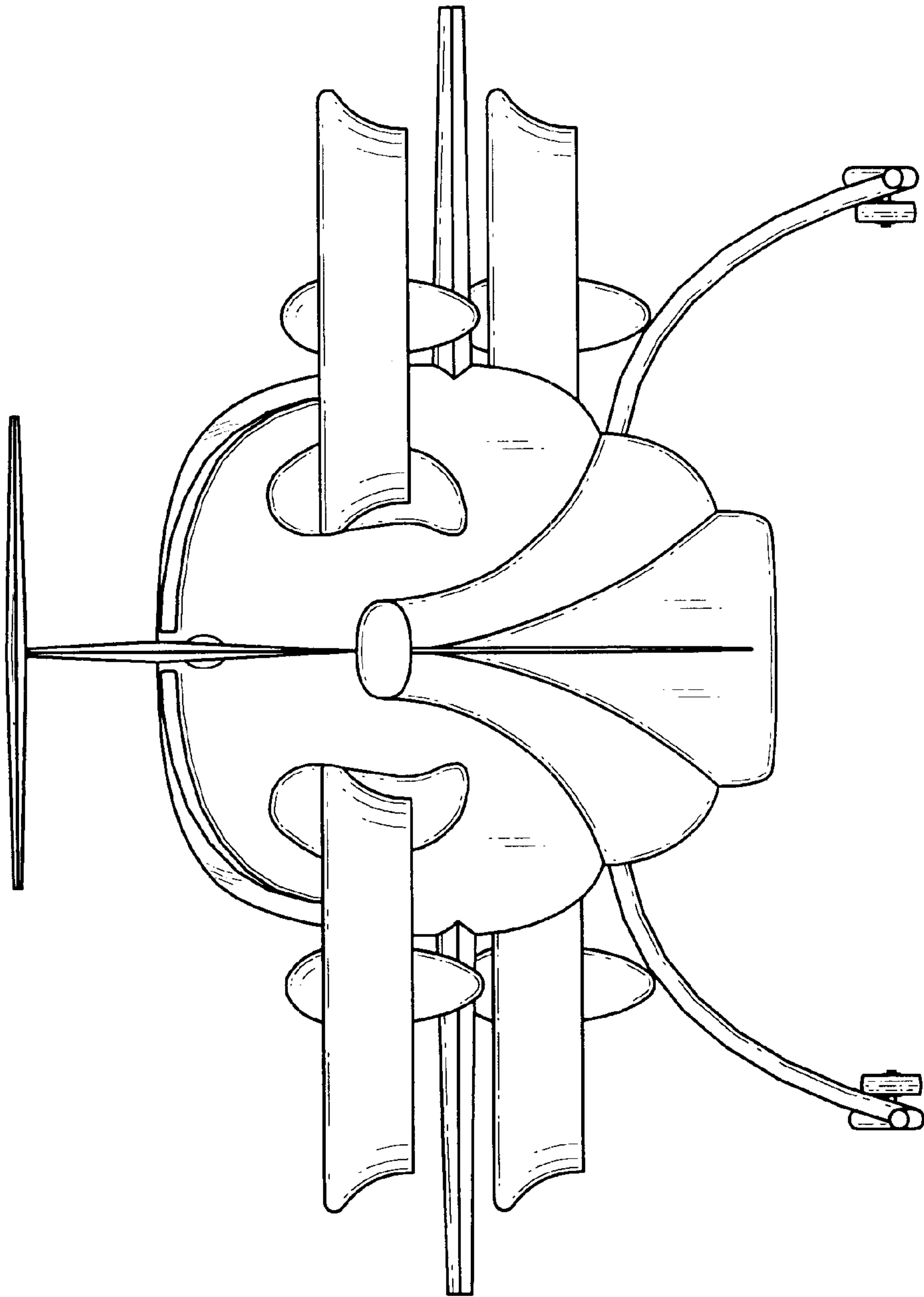

FIG. 6