



US00D454083S

(12) **United States Design Patent**
Oppenheimer

(10) **Patent No.:** **US D454,083 S**
(45) **Date of Patent:** **** Mar. 5, 2002**

(54) **ANEMOMETER DESIGN**

(76) Inventor: **Michael Oppenheimer**, 1825 S. Nugent Rd., Lummi, WA (US) 98262

(**) Term: **14 Years**

(21) Appl. No.: **29/136,786**

(22) Filed: **Feb. 6, 2001**

(51) **LOC (7) Cl.** **10-04**

(52) **U.S. Cl.** **D10/96; D10/59**

(58) **Field of Search** **D10/59, 96; 73/861.85, 73/170.01, 170.05, 170.07, 170.11, 170.12-170.15**

(56) **References Cited**

U.S. PATENT DOCUMENTS

D345,110 S * 3/1994 Lannie D10/59
6,109,116 A * 8/2000 Pelczynski 73/861.65

* cited by examiner

Primary Examiner—Antoine Duval Davis

(74) *Attorney, Agent, or Firm*—Robert B. Hughes; Hughes Law Firm, PLLC

(57) **CLAIM**

The ornamental design for an anemometer design, as shown and described.

DESCRIPTION

FIG. 1 is an isometric view of the apparatus of the present invention;

FIG. 2 is a side view of the apparatus of the present invention;

FIG. 3 is a front view of the apparatus of the present invention;

FIG. 4 is a rear view of the apparatus of the present invention;

FIG. 5 is a top view of the apparatus of the present invention;

FIG. 6 is a bottom view of the apparatus of the present invention;

FIG. 7 is an isometric view of the venturi portion of the anemometer design;

FIG. 8 is a side view of the venturi portion of the anemometer design;

FIG. 9 is a front view of the venturi portion of the anemometer design;

FIG. 10 is a rear view of the venturi portion of the anemometer design;

FIG. 11 is a top view of the venturi portion of the anemometer design;

FIG. 12 is a bottom view of the venturi portion of the anemometer design;

FIG. 13 is an isometric view of the bottom portion of the anemometer design;

FIG. 14 is a side view of the bottom portion of the anemometer design with the transparent chamber cylinders shown in hatched lines;

FIG. 15 is a front view of the bottom portion of the anemometer design;

FIG. 16 is a top view of the bottom portion of the anemometer design; and,

FIG. 17 is a bottom view of the bottom portion of the anemometer design.

1 Claim, 7 Drawing Sheets

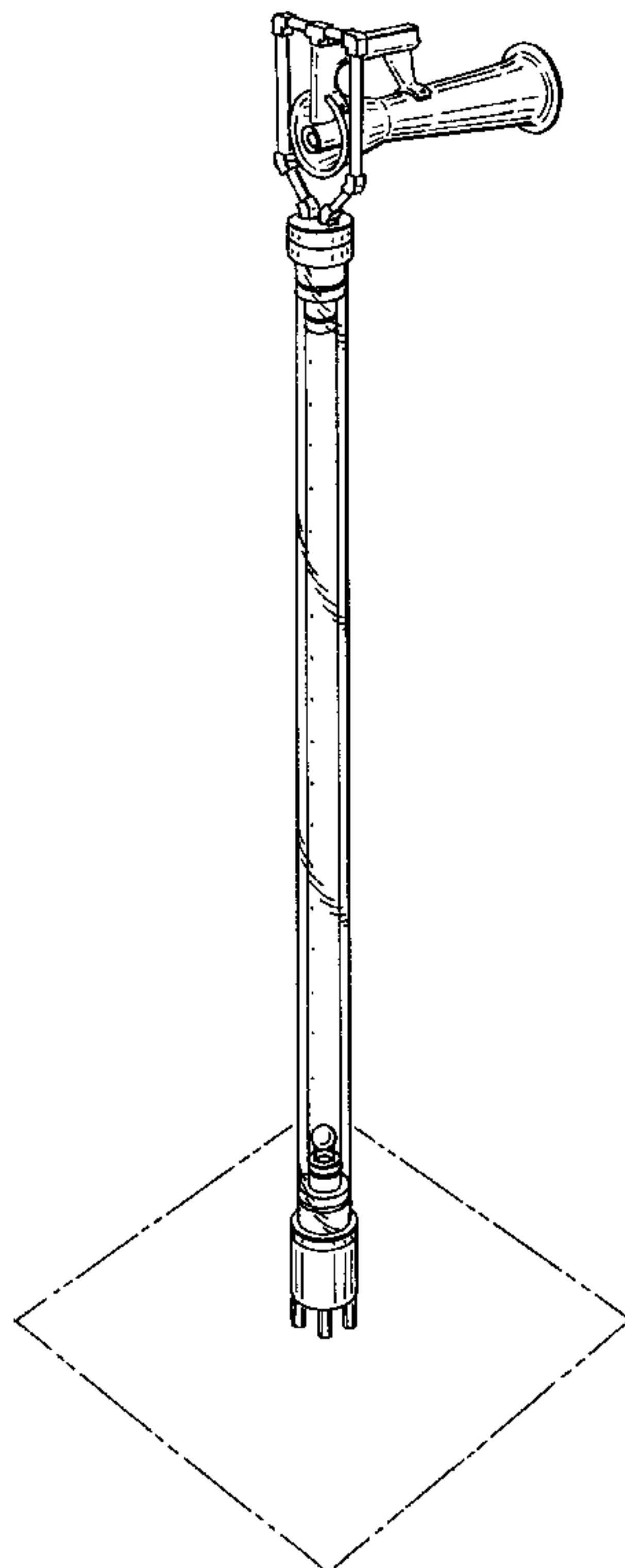

FIG. 1

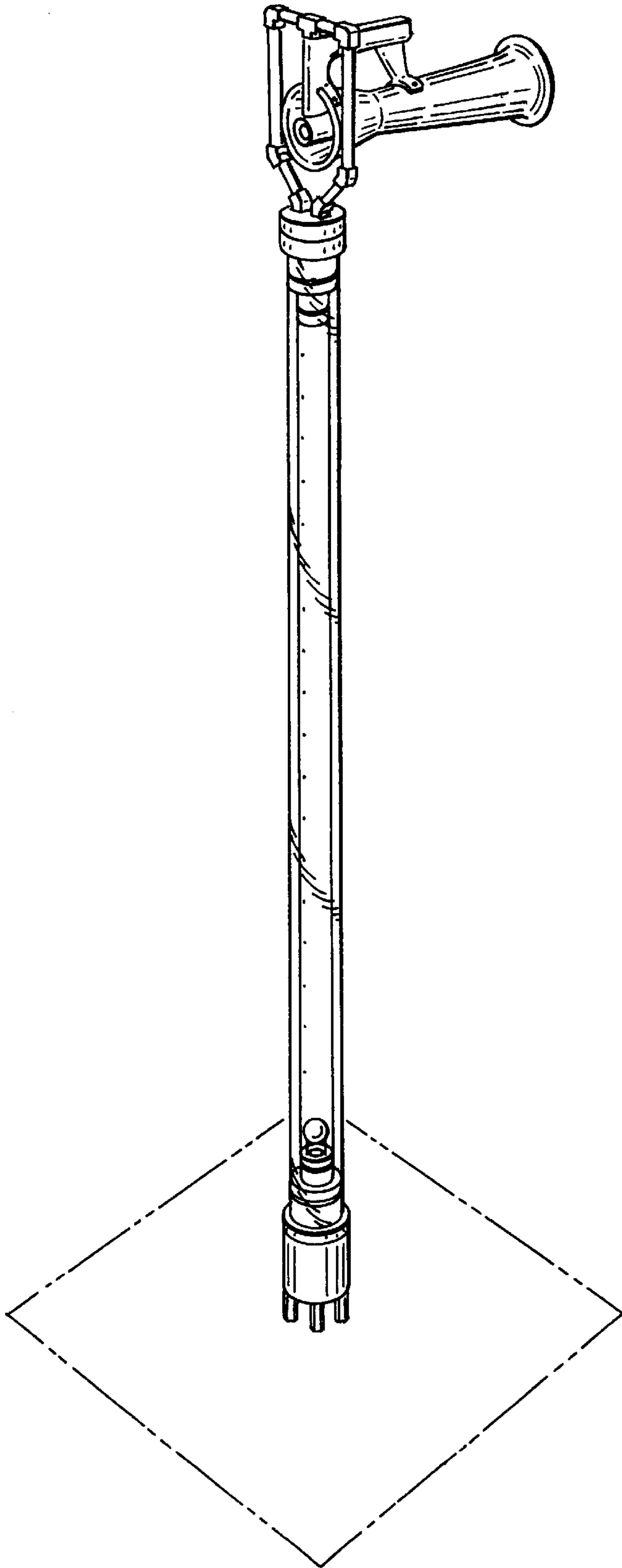

FIG. 2

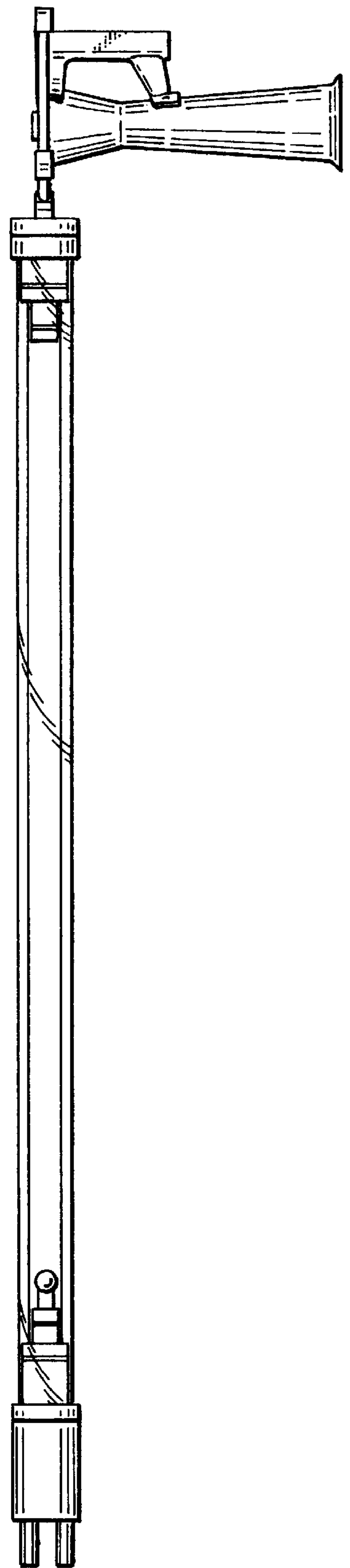

FIG. 3

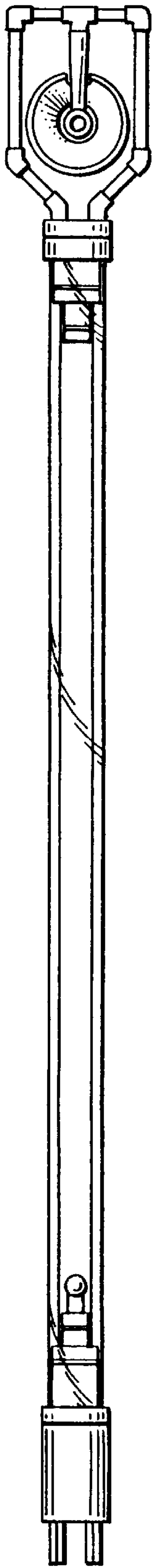

FIG. 4

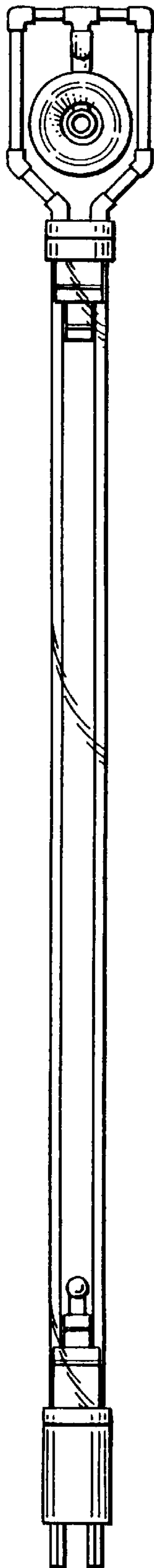

FIG. 5

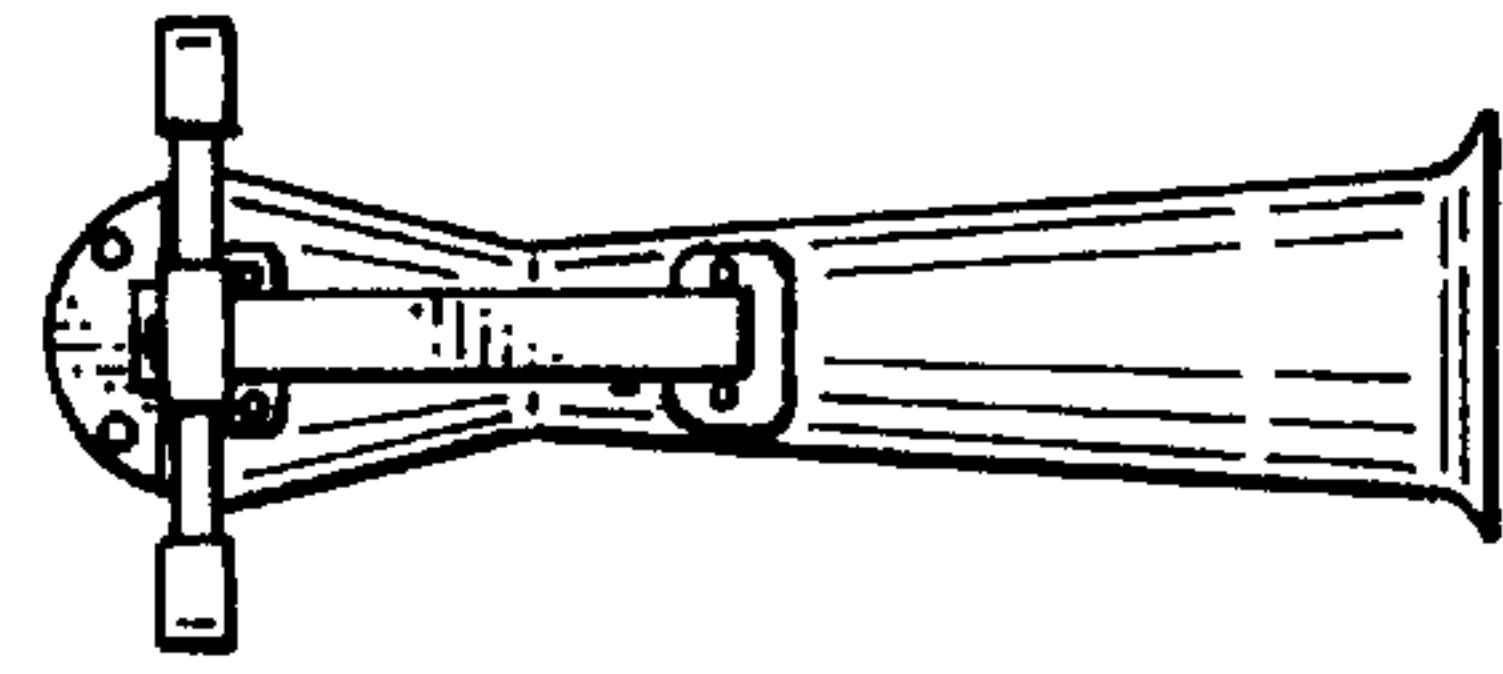

FIG. 6

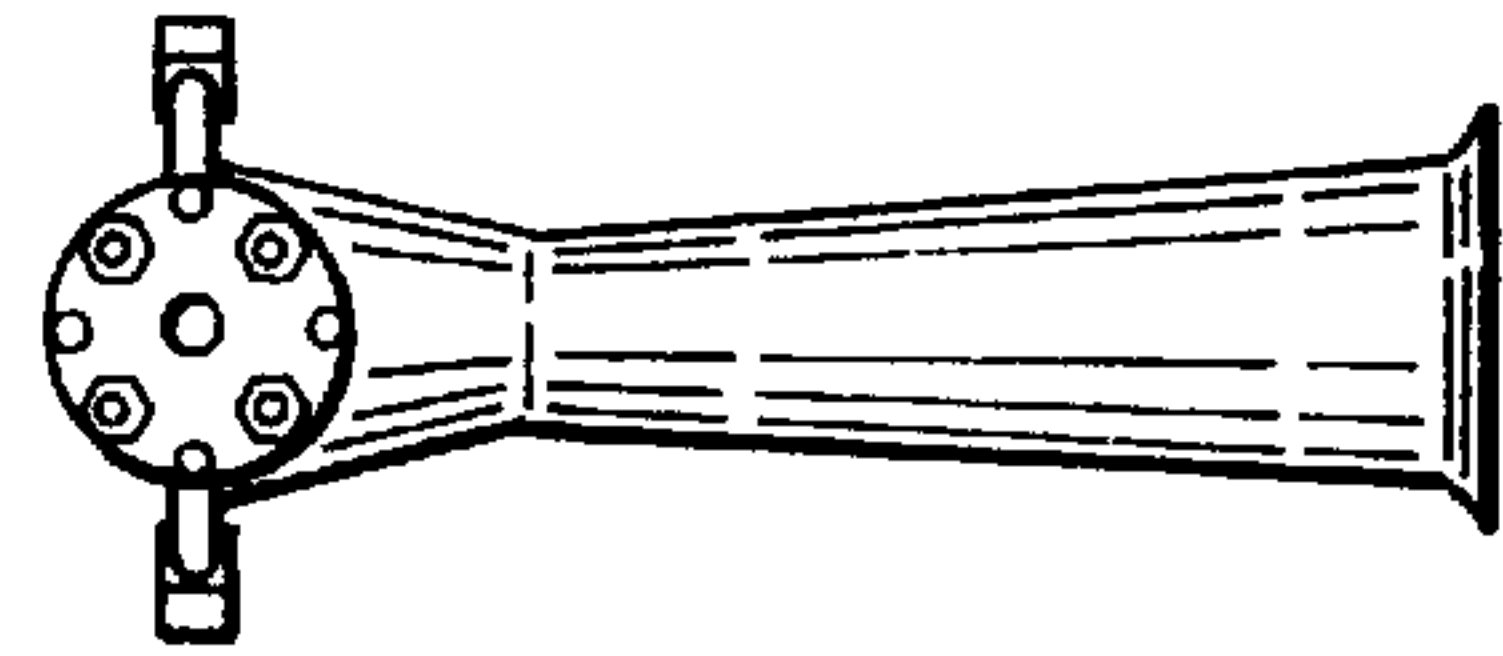

FIG. 7

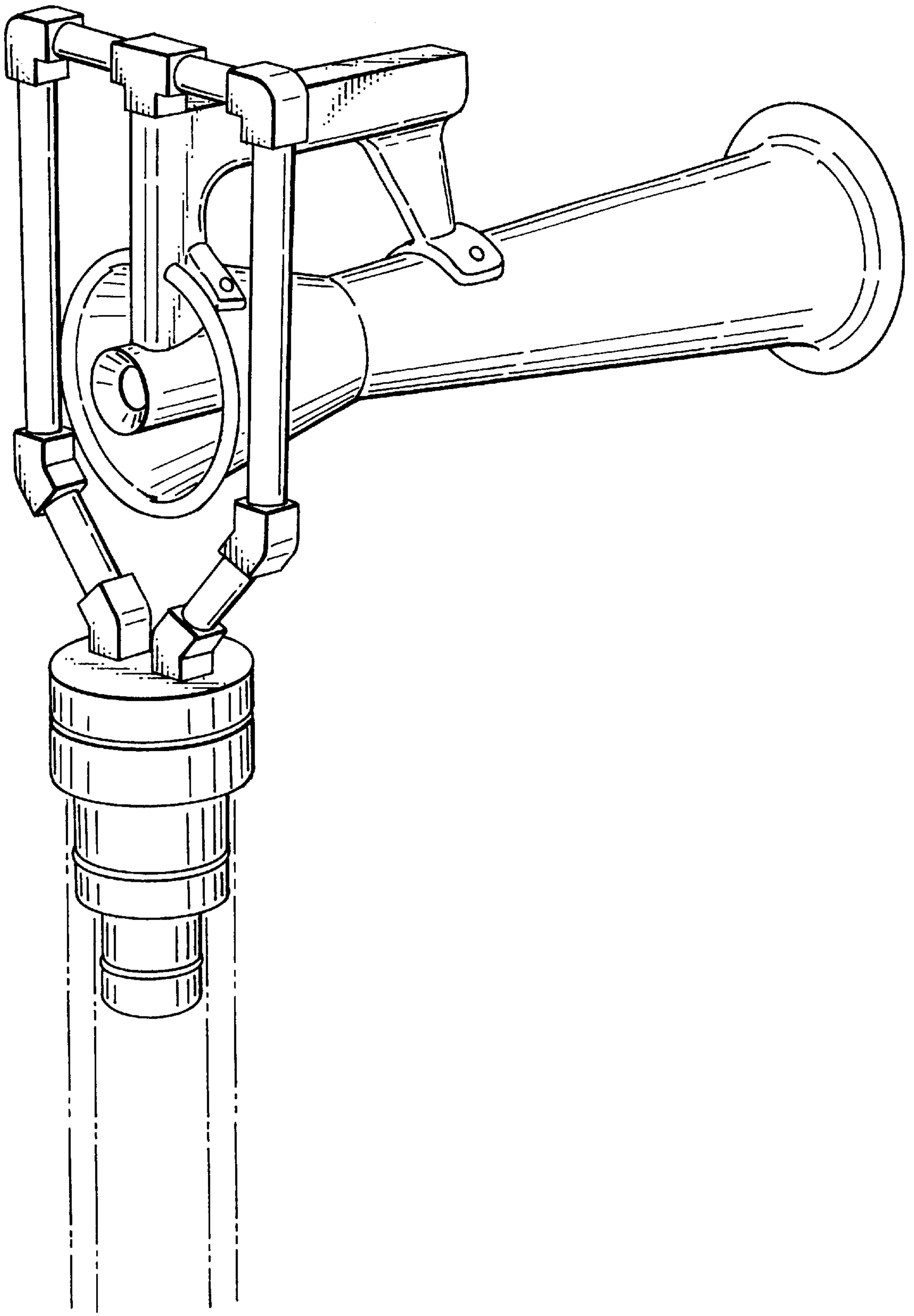

FIG. 8

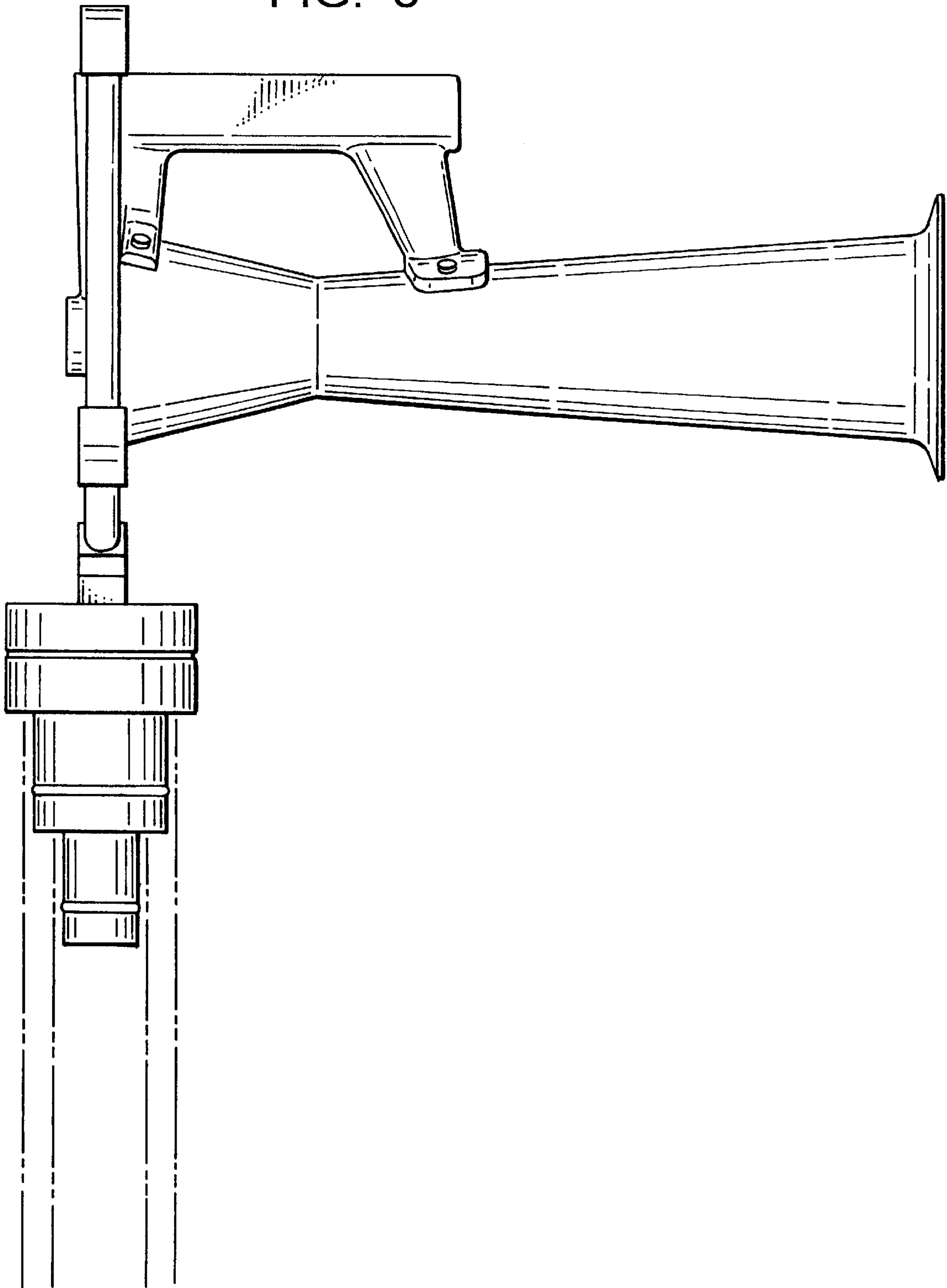

FIG. 9

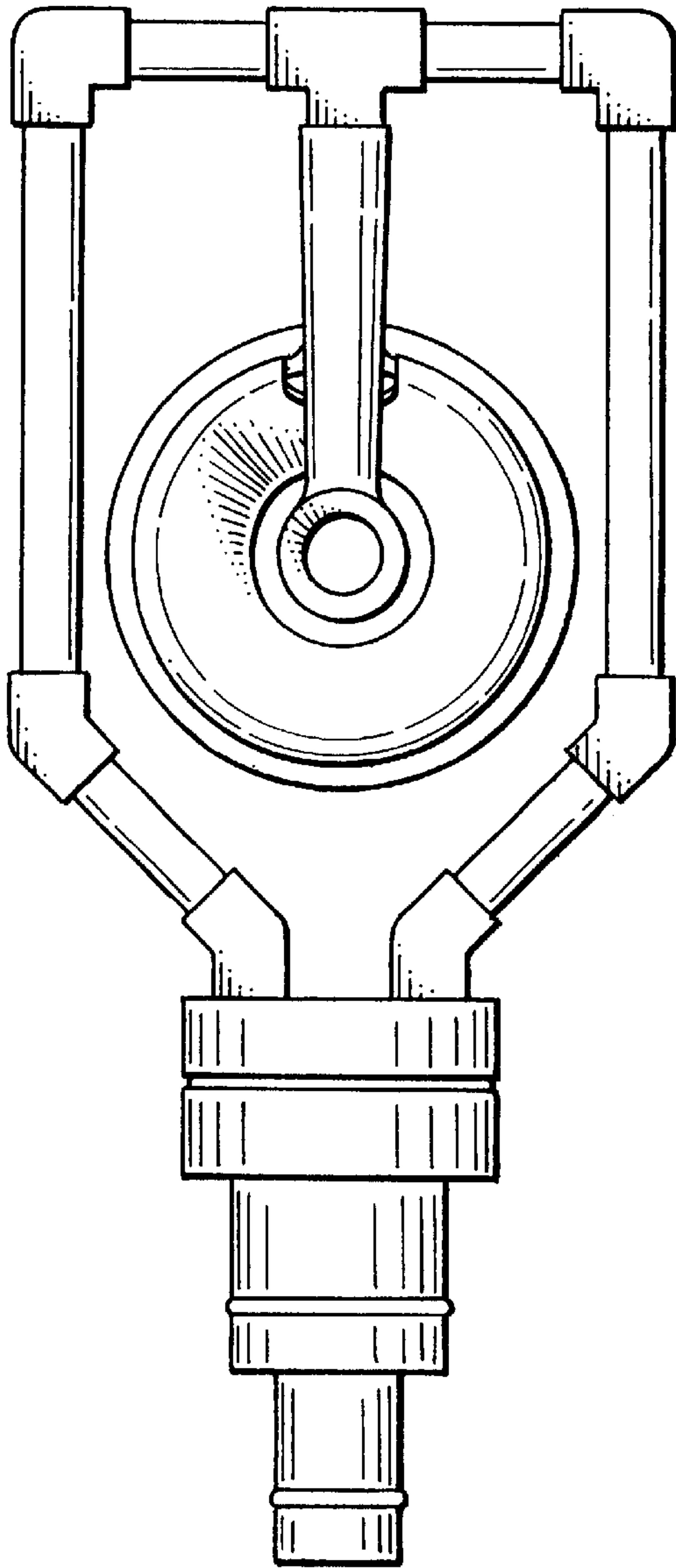

FIG. 10

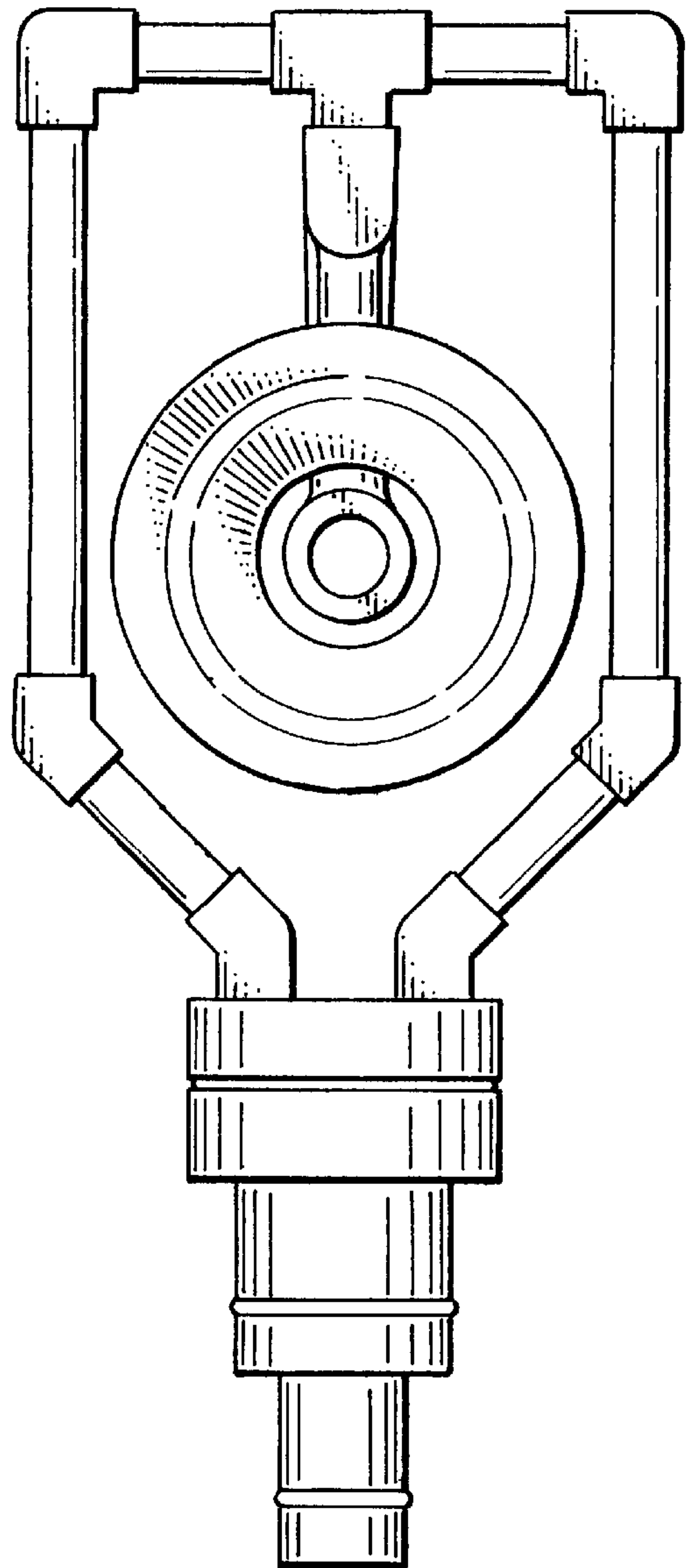

FIG. 11

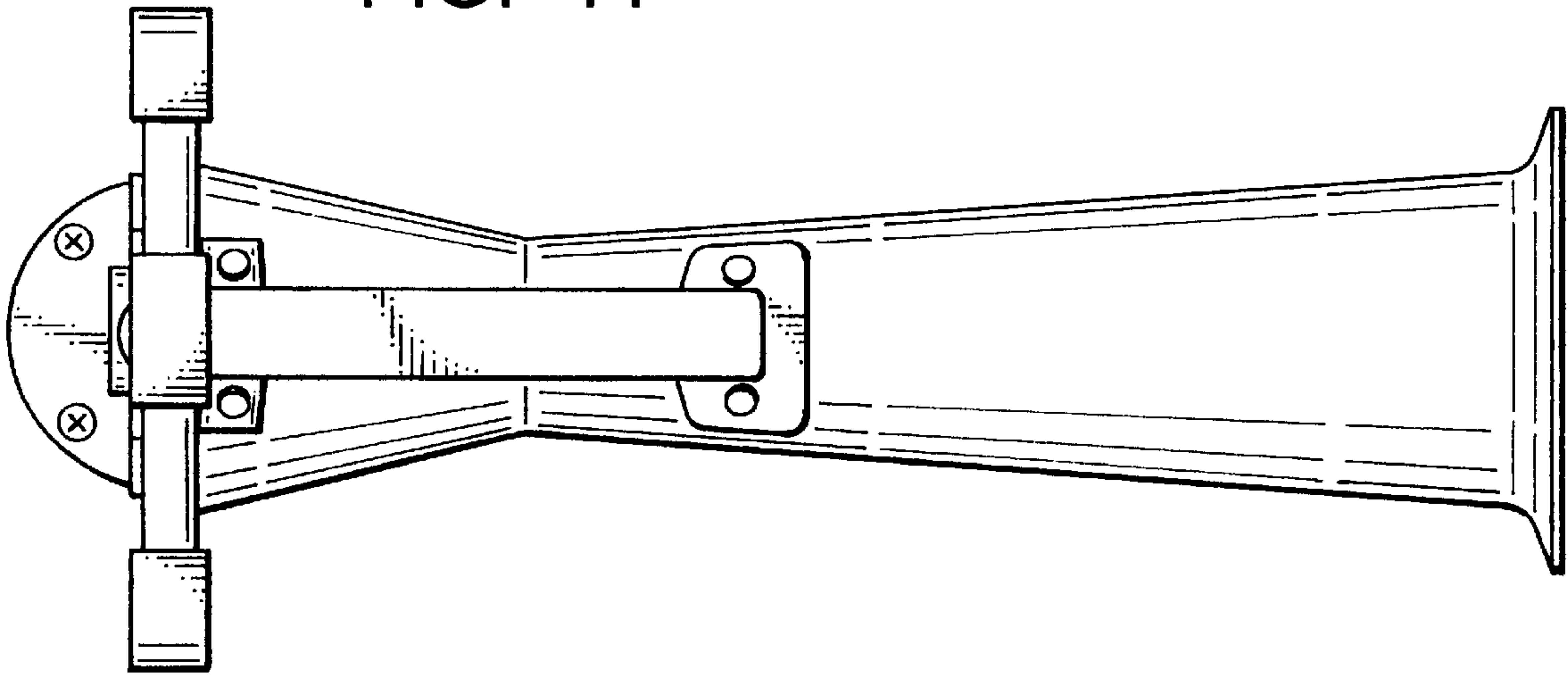

FIG. 12

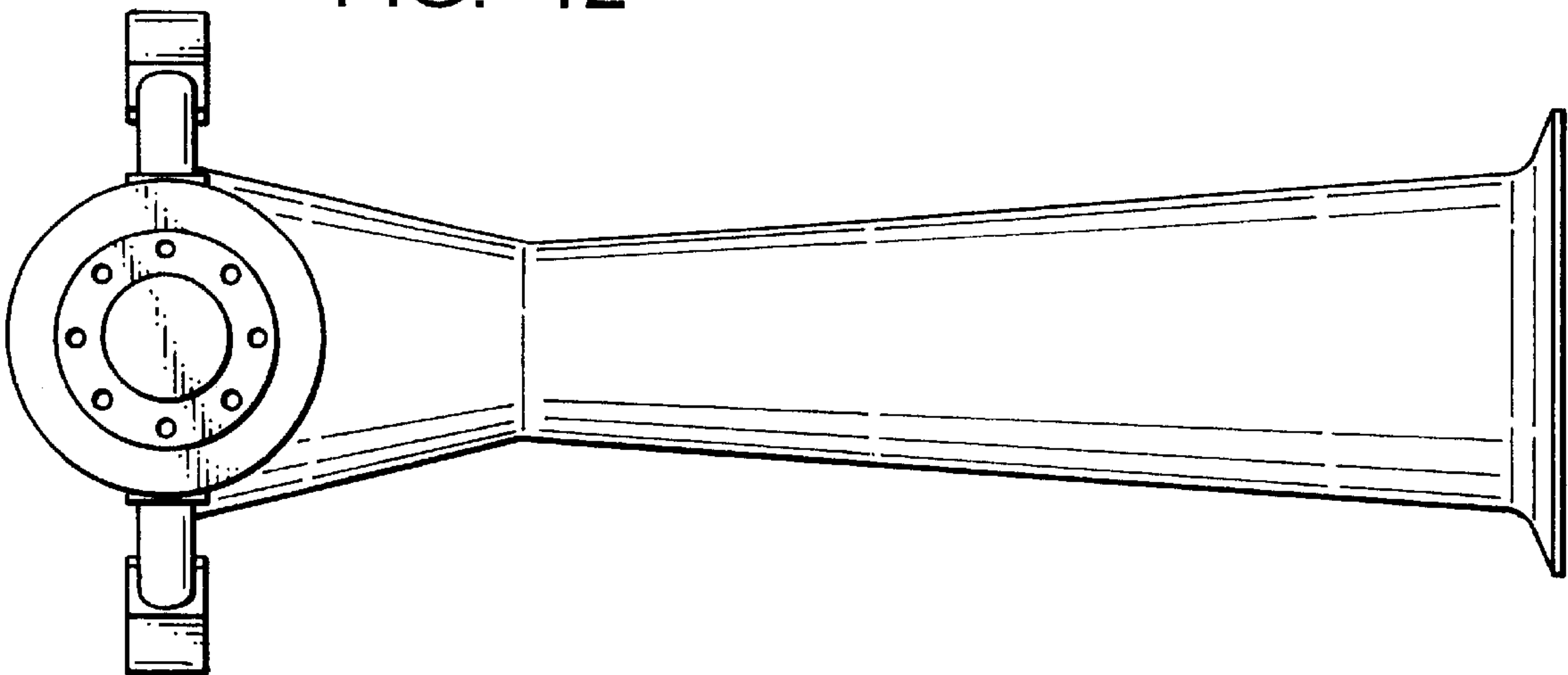

FIG. 13

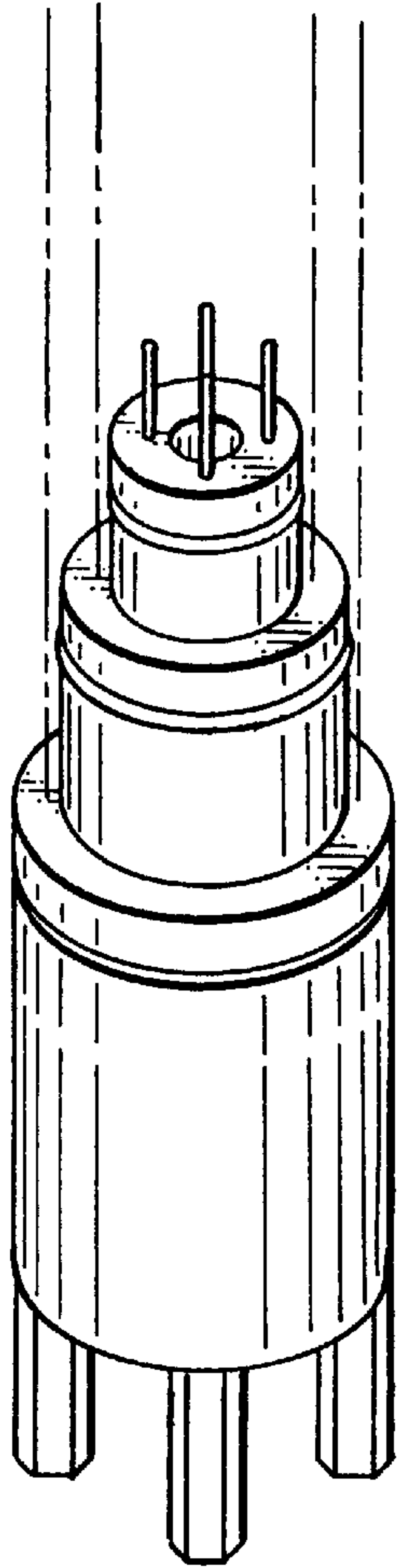

FIG. 14

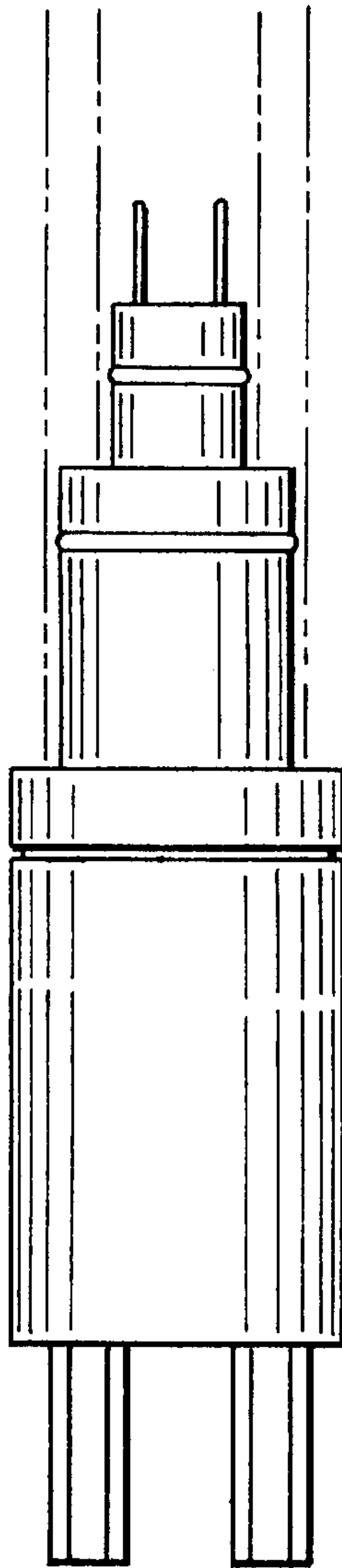

FIG. 15

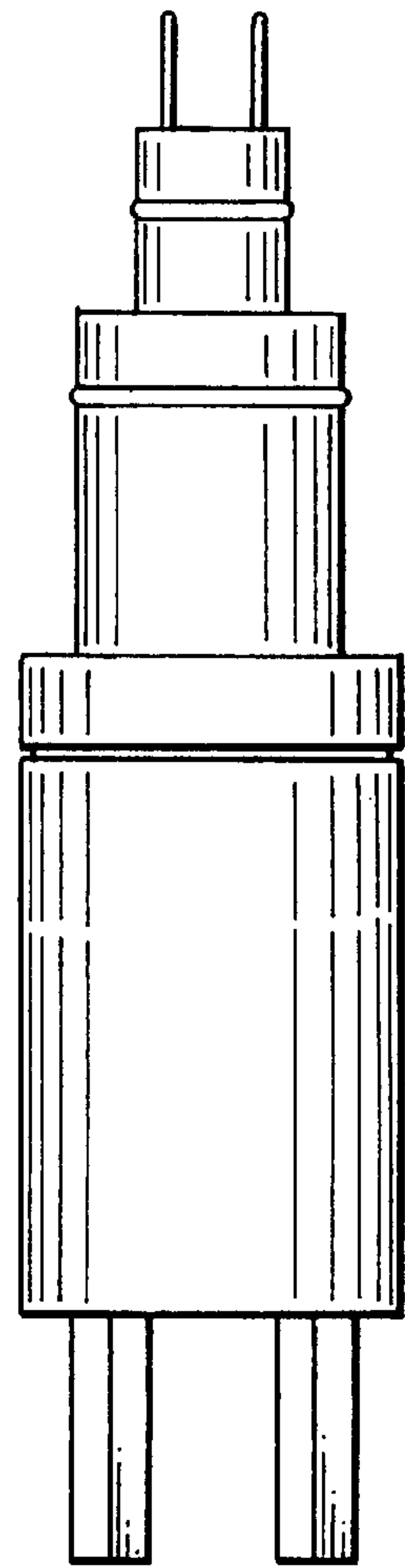

FIG. 16

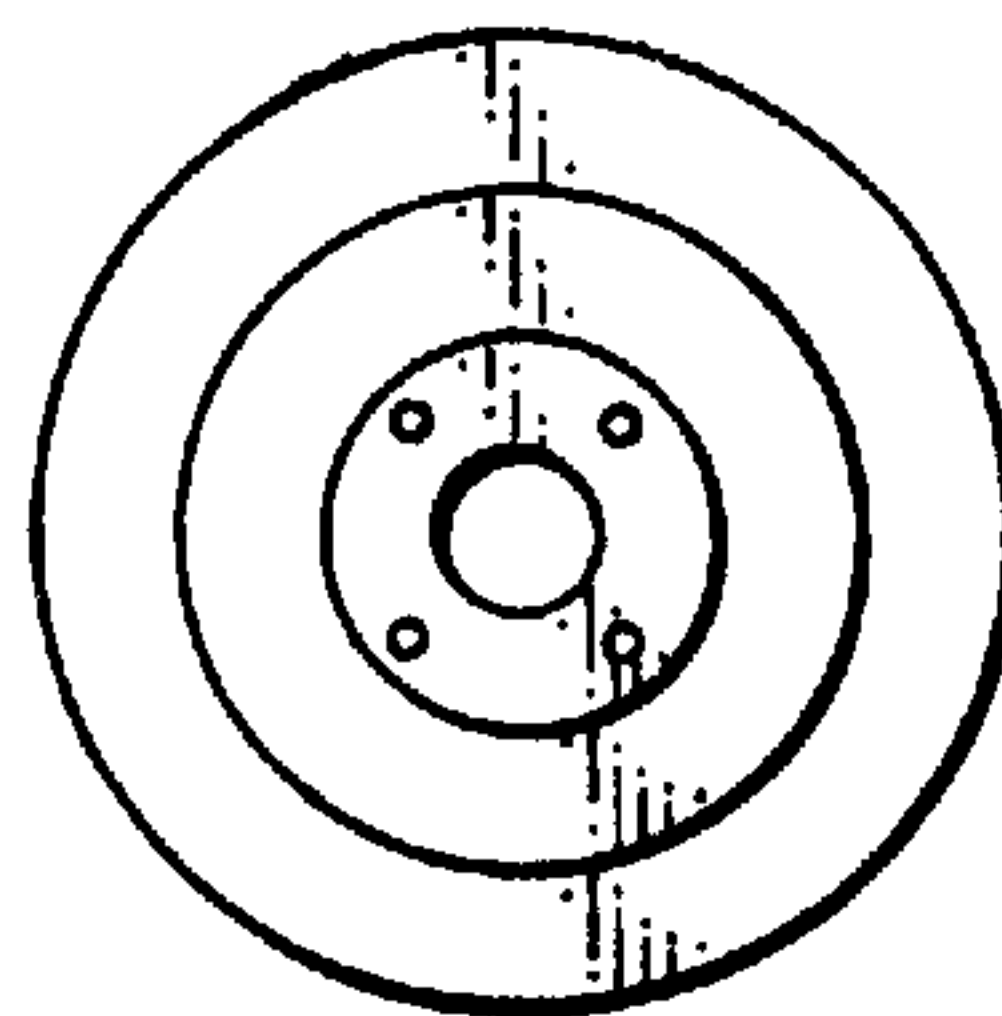

FIG. 17

