



US00D453747S

(12) **United States Design Patent**  
**Kita**

(10) **Patent No.:** **US D453,747 S**

(45) **Date of Patent:** **\*\* Feb. 19, 2002**

(54) **TELEVISION SET**

(75) Inventor: **Toshiyuki Kita**, Osaka-fu (JP)

(73) Assignee: **Sharp Kabushiki Kaisha**, Osaka (JP)

(\*\*) Term: **14 Years**

(21) Appl. No.: **29/143,559**

(22) Filed: **Jun. 18, 2001**

(30) **Foreign Application Priority Data**

Dec. 18, 2000 (JP) ..... 2000-036136

(51) **LOC (7) Cl.** ..... **14-03**

(52) **U.S. Cl.** ..... **D14/126; D14/134**

(58) **Field of Search** ..... D14/125-134,  
D14/239, 371, 374-382; D6/498; 312/7.2;  
348/836, 838, 180, 184, 325, 739; 345/905,  
104, 133, 156, 168, 87, 173; 341/12; 248/917-924

(56) **References Cited**

**U.S. PATENT DOCUMENTS**

- D356,081 S \* 3/1995 Naito ..... D14/134
- D412,166 S \* 7/1999 Takagi ..... D14/126
- D421,601 S \* 3/2000 Chou ..... D14/375
- D427,169 S 6/2000 Saeki et al.

- D429,227 S 8/2000 Shimizu
- D431,537 S 10/2000 Saeki et al.
- D431,564 S \* 10/2000 Masuda ..... D14/374
- D434,037 S \* 11/2000 Chang ..... D14/375
- D438,848 S 3/2001 Kita
- D439,224 S 3/2001 Kita
- D439,225 S 3/2001 Kita

\* cited by examiner

*Primary Examiner*—Raphael Barkai

(74) *Attorney, Agent, or Firm*—Nixon & Vanderhye

(57) **CLAIM**

The ornamental design for a television set, as shown and described.

**DESCRIPTION**

FIG. 1 is a top, front and right side perspective view of a television set according to my design;  
 FIG. 2 is a front elevational view thereof;  
 FIG. 3 is a top plan view thereof;  
 FIG. 4 is a rear elevational view thereof;  
 FIG. 5 is a bottom plan view thereof;  
 FIG. 6 is a right side elevational view thereof;  
 FIG. 7 is a left side elevation view thereof; and,  
 FIG. 8 is a top, rear and right side perspective view thereof.

**1 Claim, 6 Drawing Sheets**

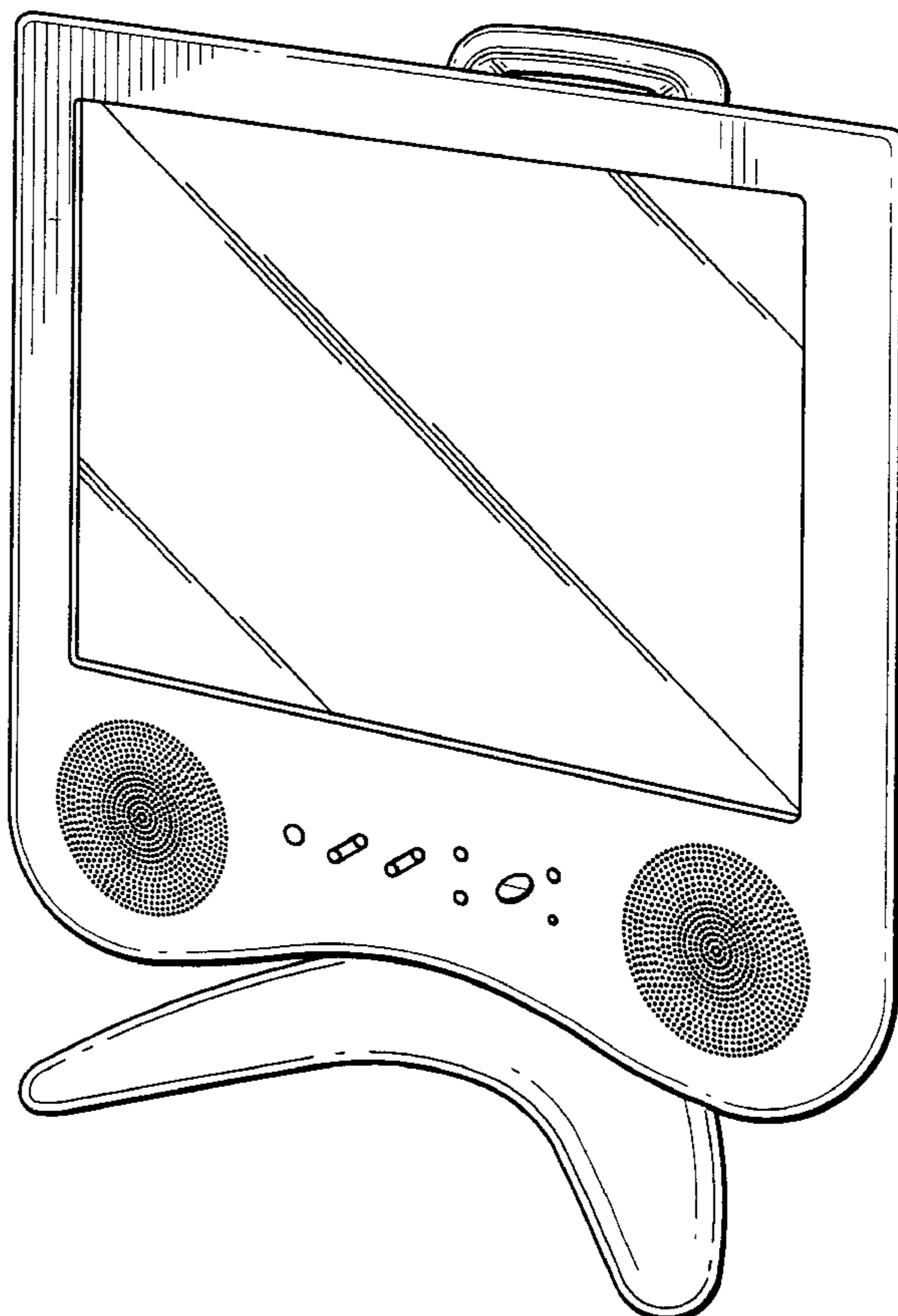

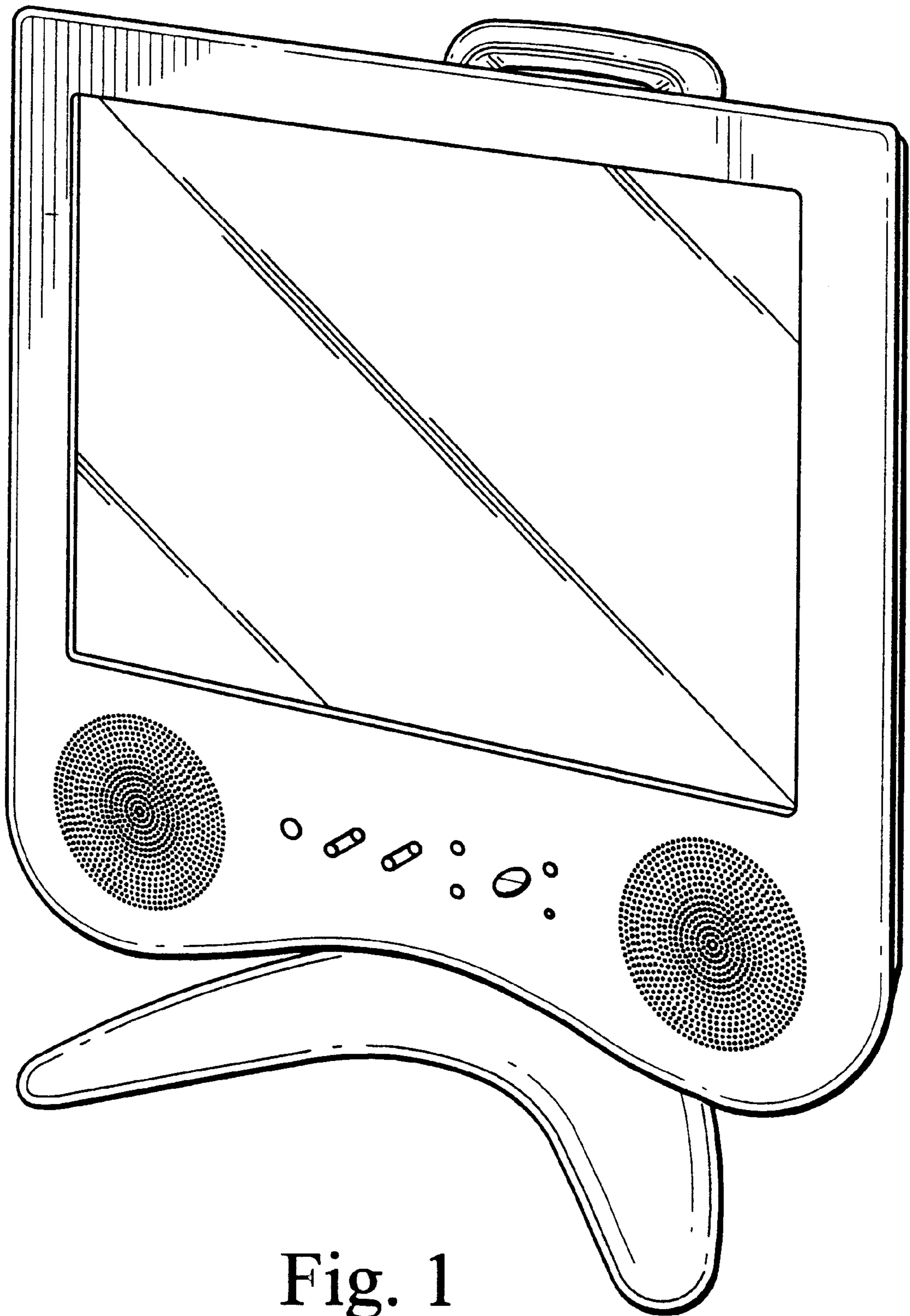

Fig. 1

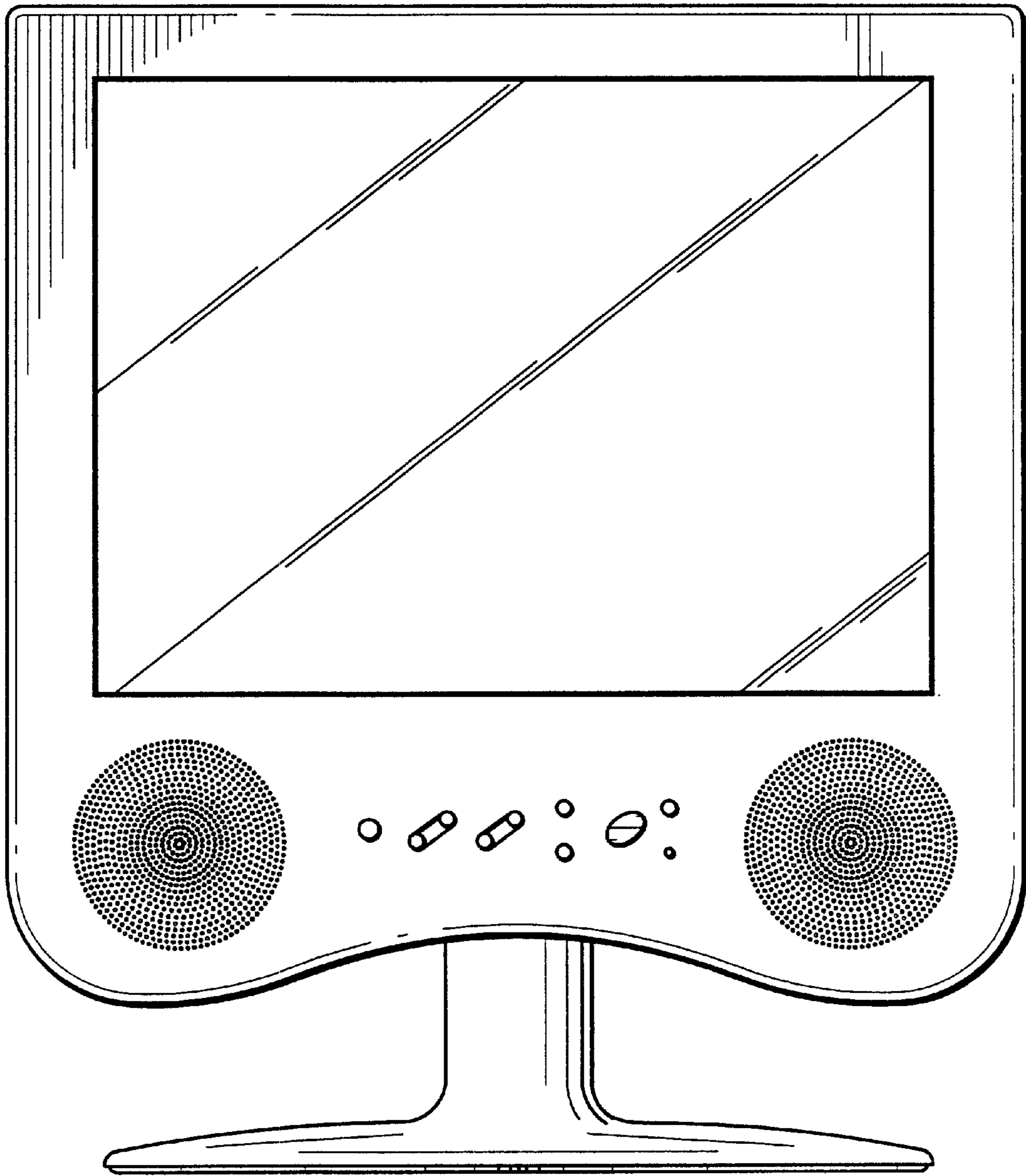

Fig. 2



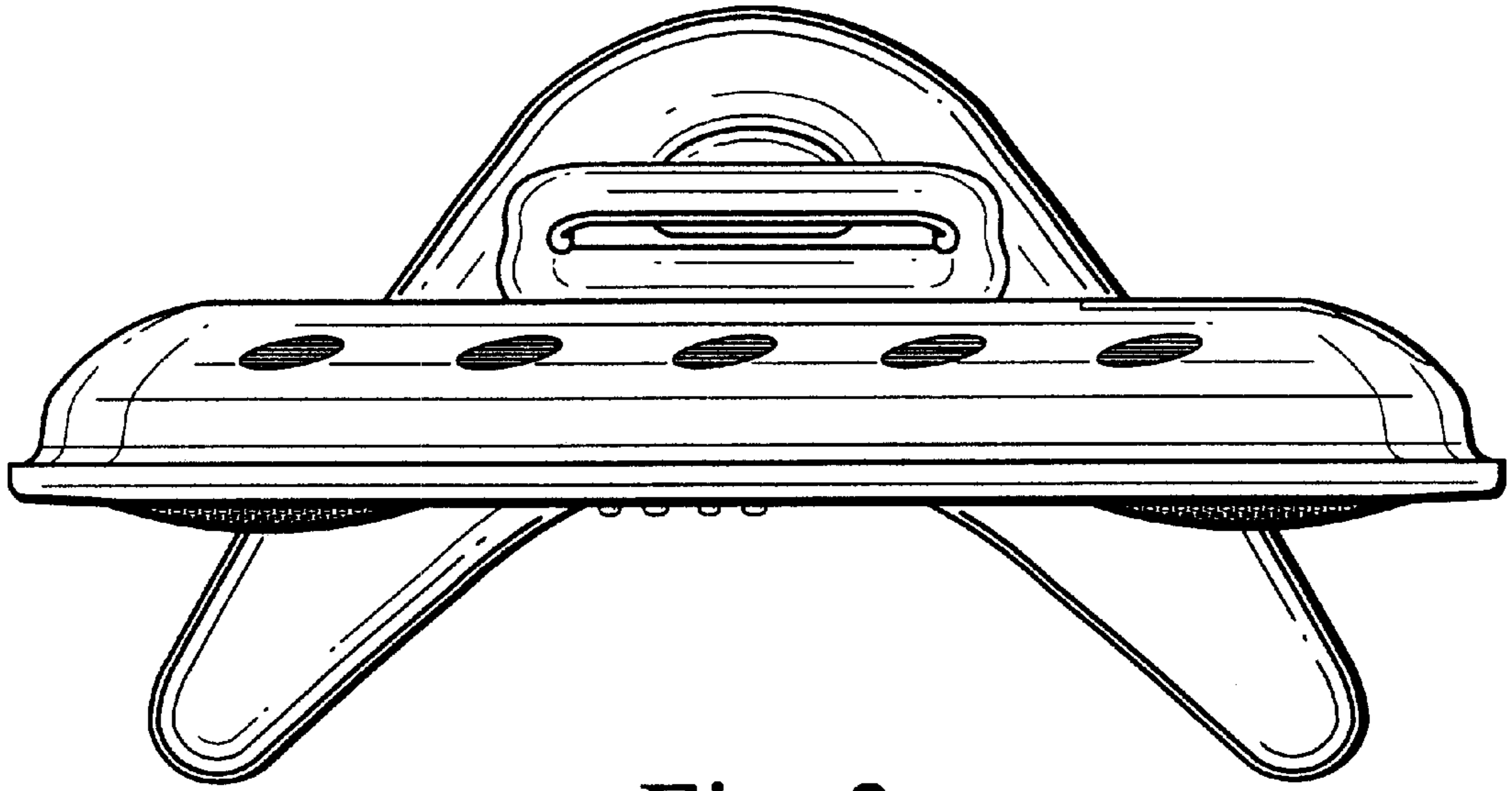

Fig. 3

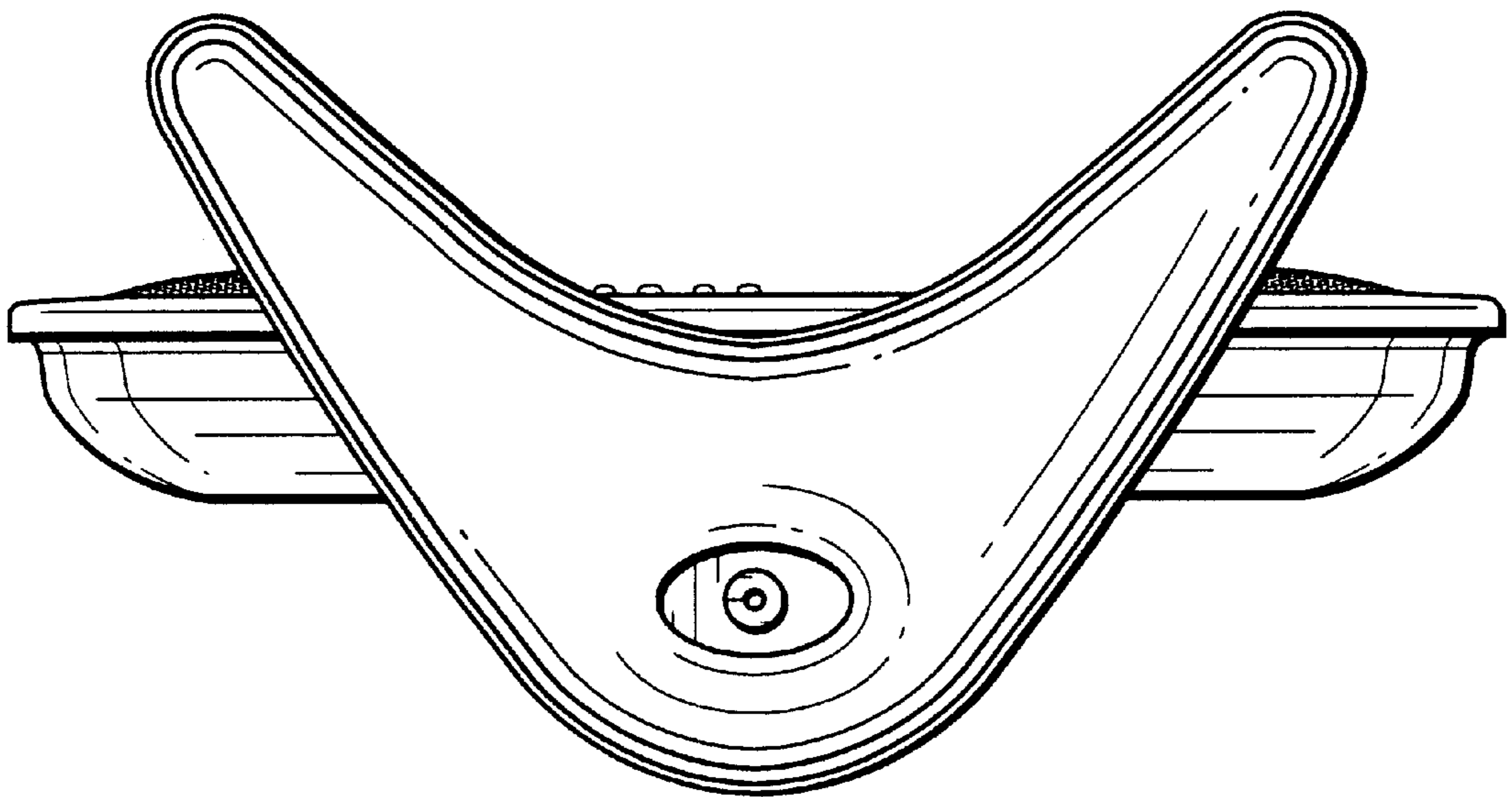

Fig. 5

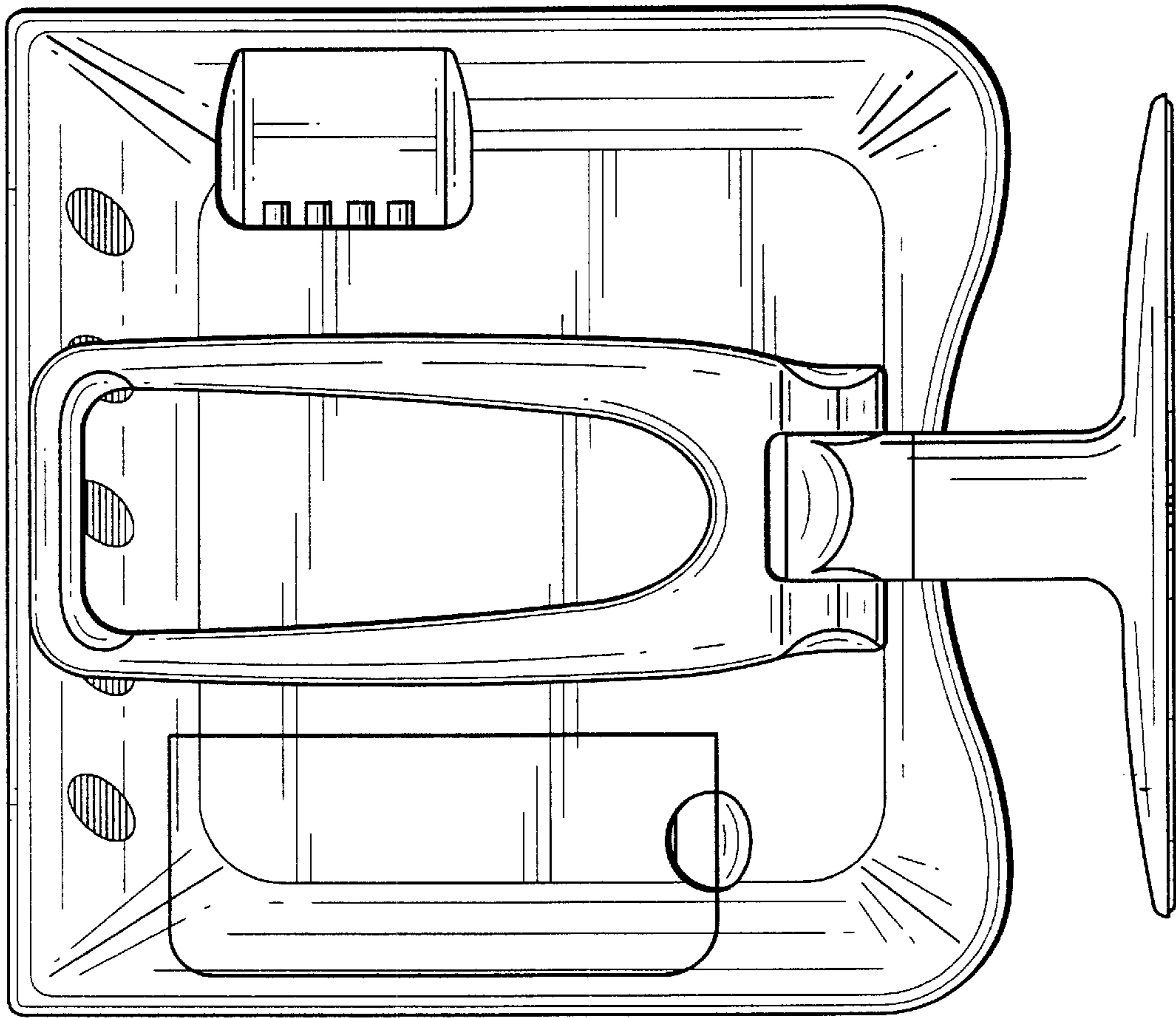

Fig. 4

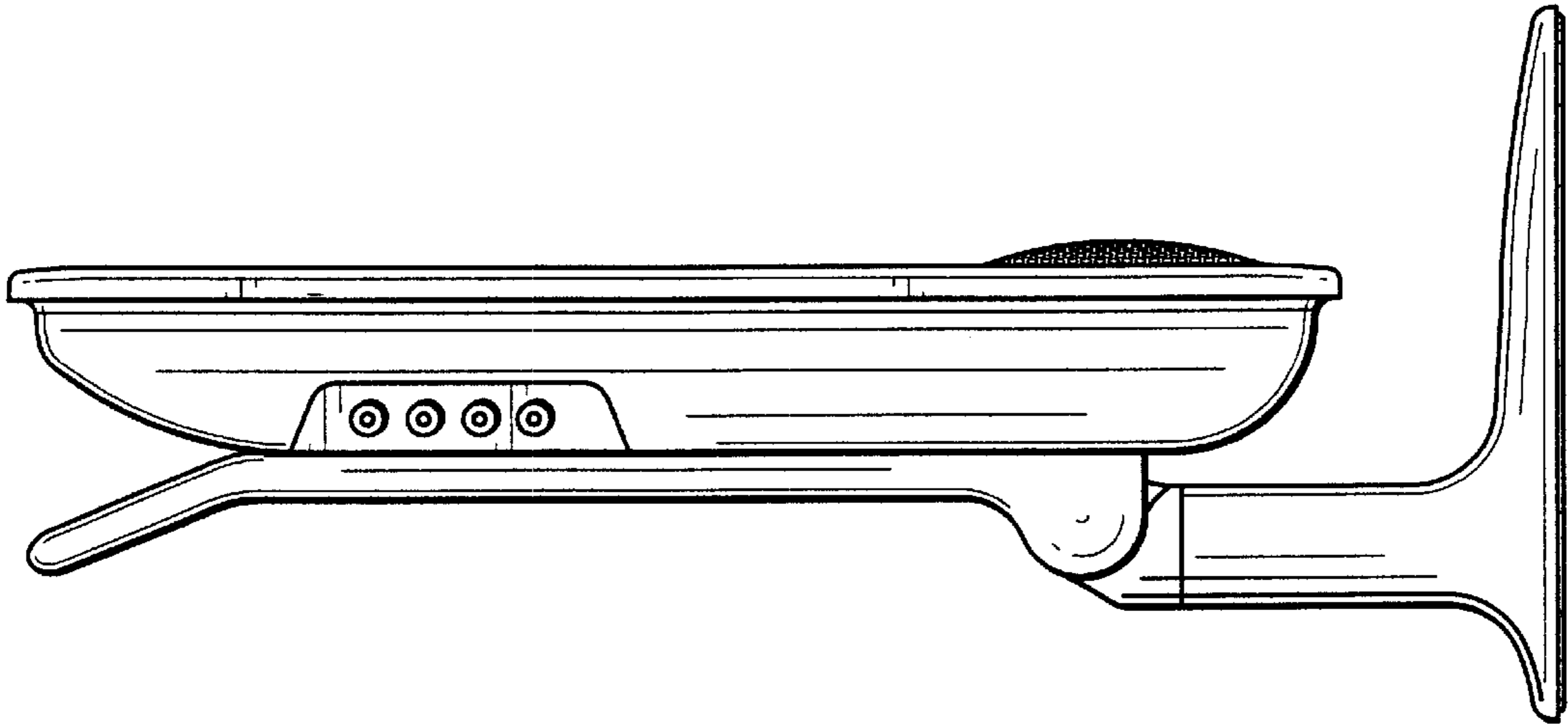

Fig. 7

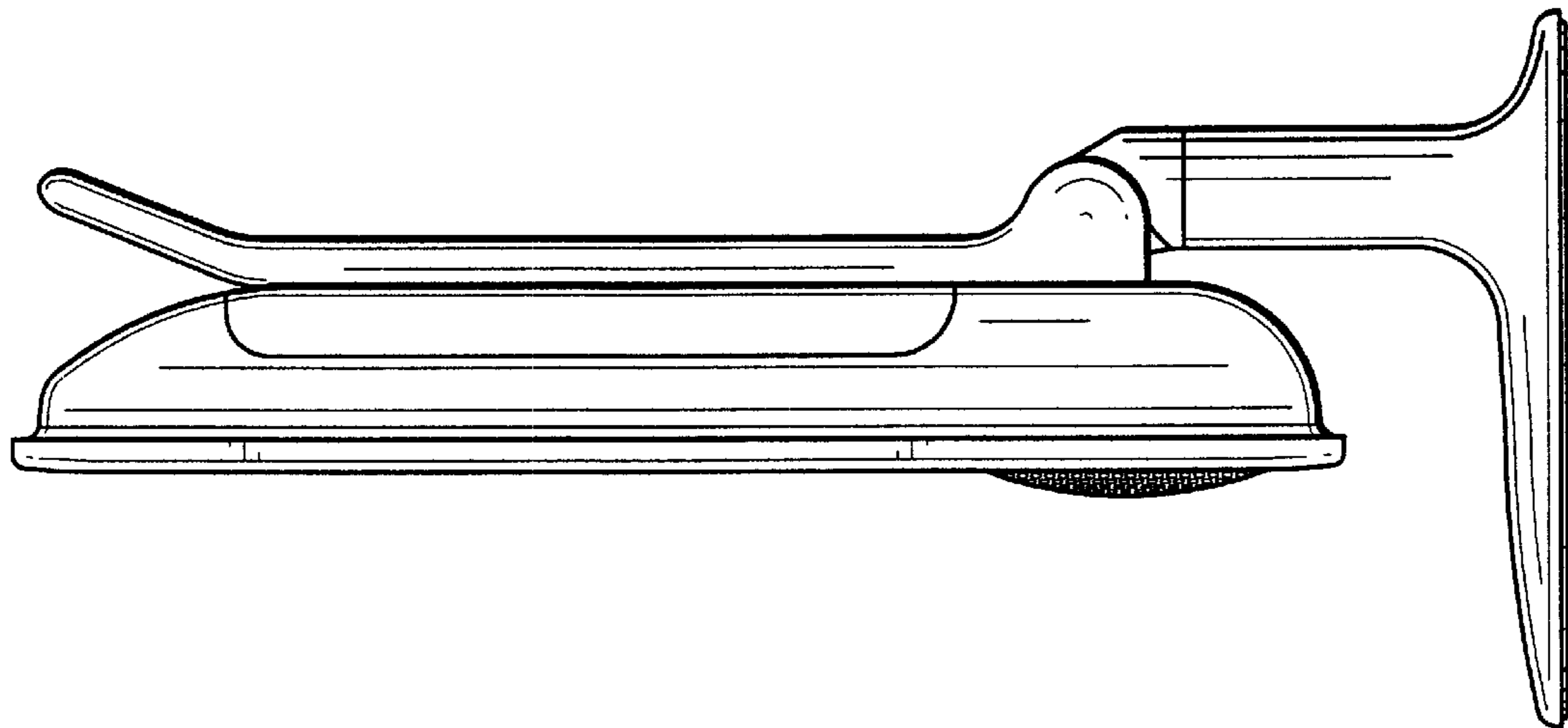

Fig. 6

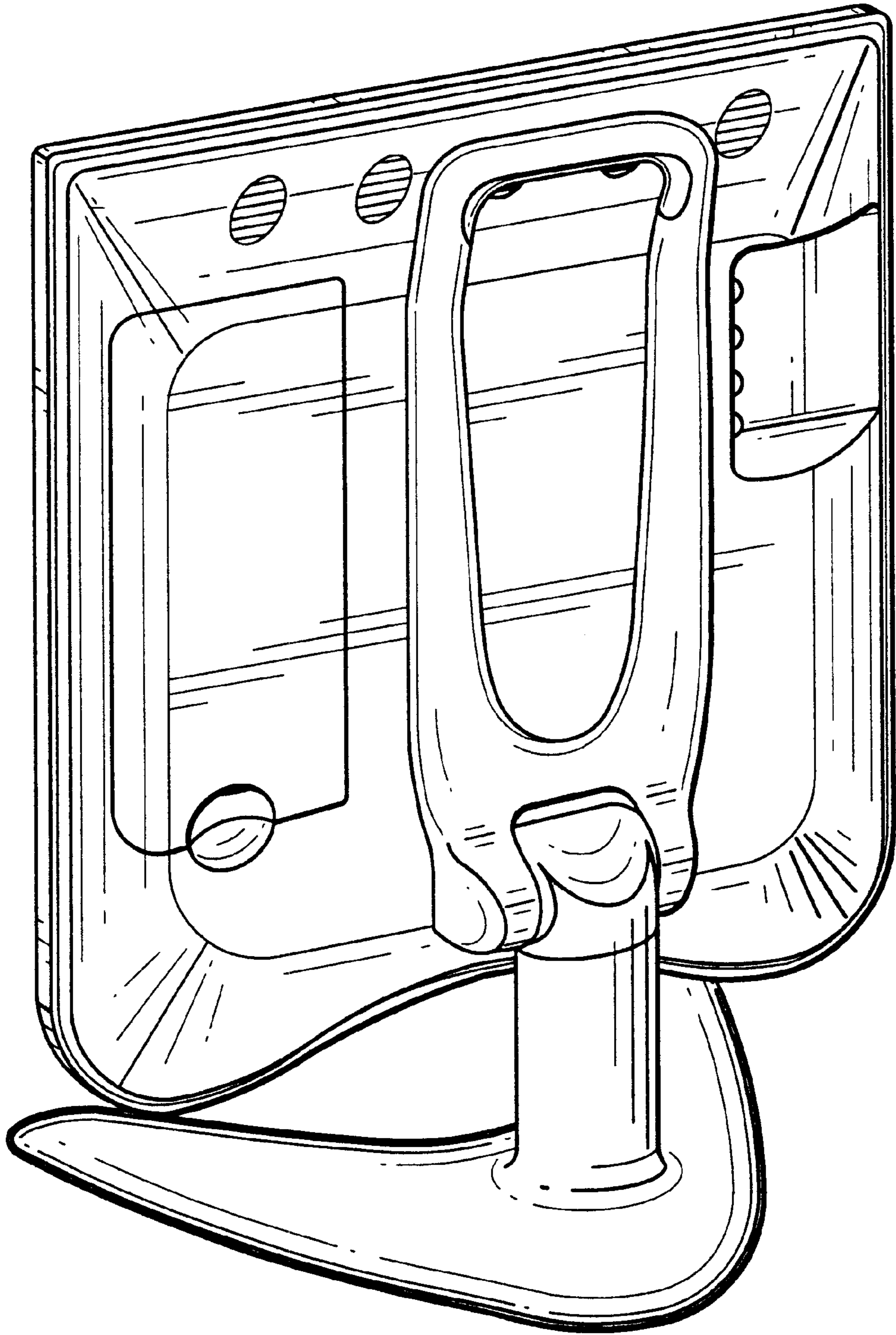

Fig. 8