



US00D453720S

(12) **United States Design Patent**
Conway

(10) **Patent No.:** **US D453,720 S**

(45) **Date of Patent:** **** Feb. 19, 2002**

(54) **FENDER LINER FOR A TRUCK**
(75) Inventor: **Scott M. Conway**, Flower Mound, TX
(US)
(73) Assignee: **Paccar Inc**, Bellevue, WA (US)
(**) Term: **14 Years**

D393,436 S * 4/1998 Williams D12/173
D412,689 S * 8/1999 Onopa D12/173
D424,001 S * 5/2000 Englander D12/187
D426,800 S * 6/2000 Zimmerman D12/173
D432,472 S * 10/2000 Tart D12/185
D436,563 S * 1/2001 Delashaw et al. D12/173

* cited by examiner

Primary Examiner—Melody N. Brown
(74) *Attorney, Agent, or Firm*—Sidley Austin Brown & Wood

(21) Appl. No.: **29/146,668**
(22) Filed: **Aug. 13, 2001**

Related U.S. Application Data

(62) Division of application No. 29/117,628, filed on Jan. 28, 2000.
(51) **LOC (7) Cl.** **12-16**
(52) **U.S. Cl.** **D12/185**
(58) **Field of Search** D12/185, 223,
D12/196, 93, 173, 96, 106; 280/414.3,
847, 849-851, 166, 154; 296/190; 180/69.2,
89.1, 89.12

(57) **CLAIM**

The ornamental design for a fender liner for a truck, as shown and described.

DESCRIPTION

FIG. 1 is a perspective view of a fender liner for a truck of my new design which is suitable for use on the right side of a truck hood;
FIG. 2 is a front view of FIG. 1;
FIG. 3 is a top view of FIG. 1;
FIG. 4 is a right side view of FIG. 1;
FIG. 5 is a back view of FIG. 1; and,
FIG. 6 is a left side view of FIG. 1.
The broken lines shown in FIGS. 4 and 5 are for illustrative purposes only and form no part of the claimed design.

(56) **References Cited**
U.S. PATENT DOCUMENTS

5,267,752 A * 12/1993 Miller 280/848
5,460,411 A * 10/1995 Becker 280/851
D367,027 S * 2/1996 Onopa D12/173

1 Claim, 6 Drawing Sheets

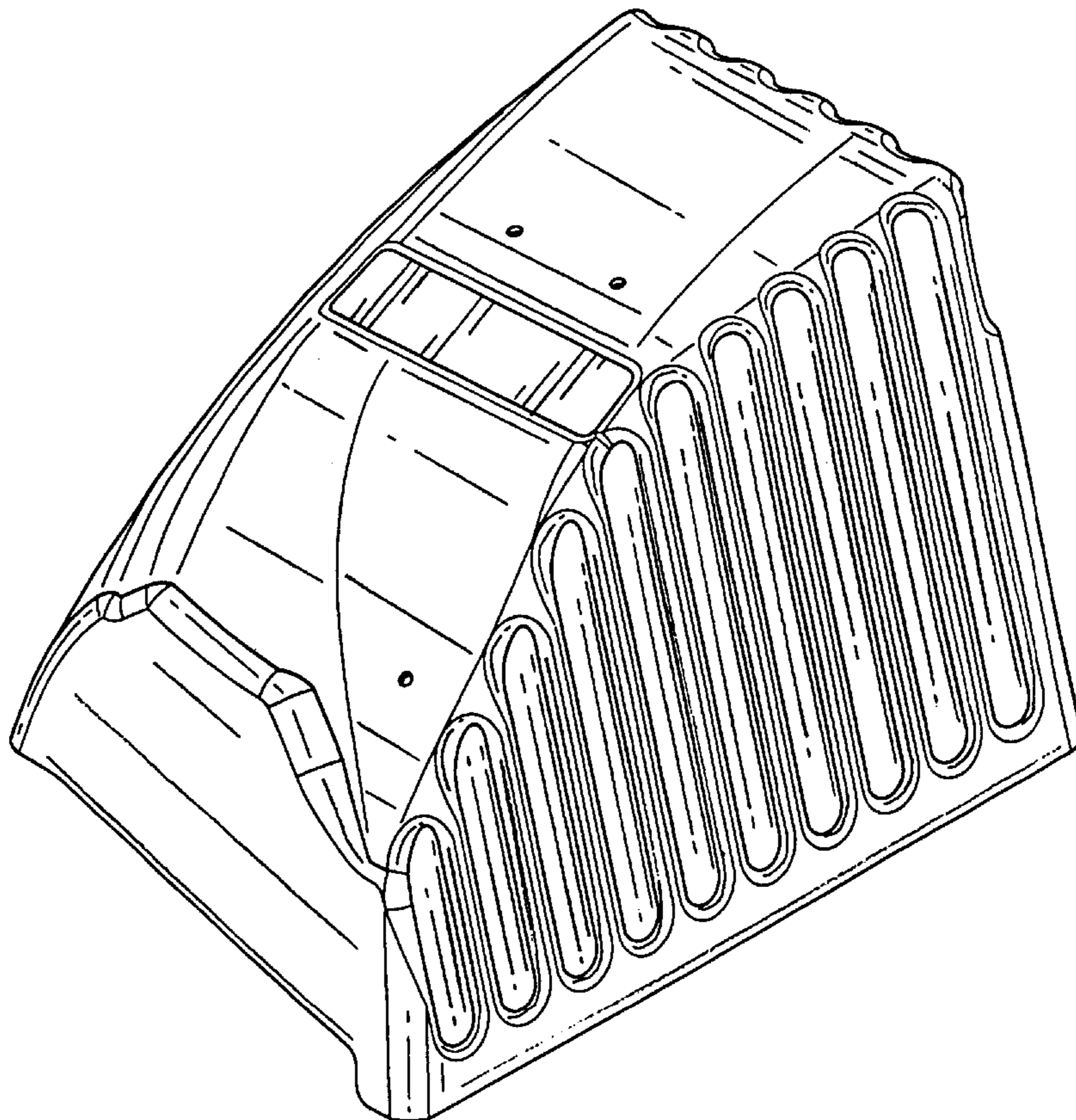

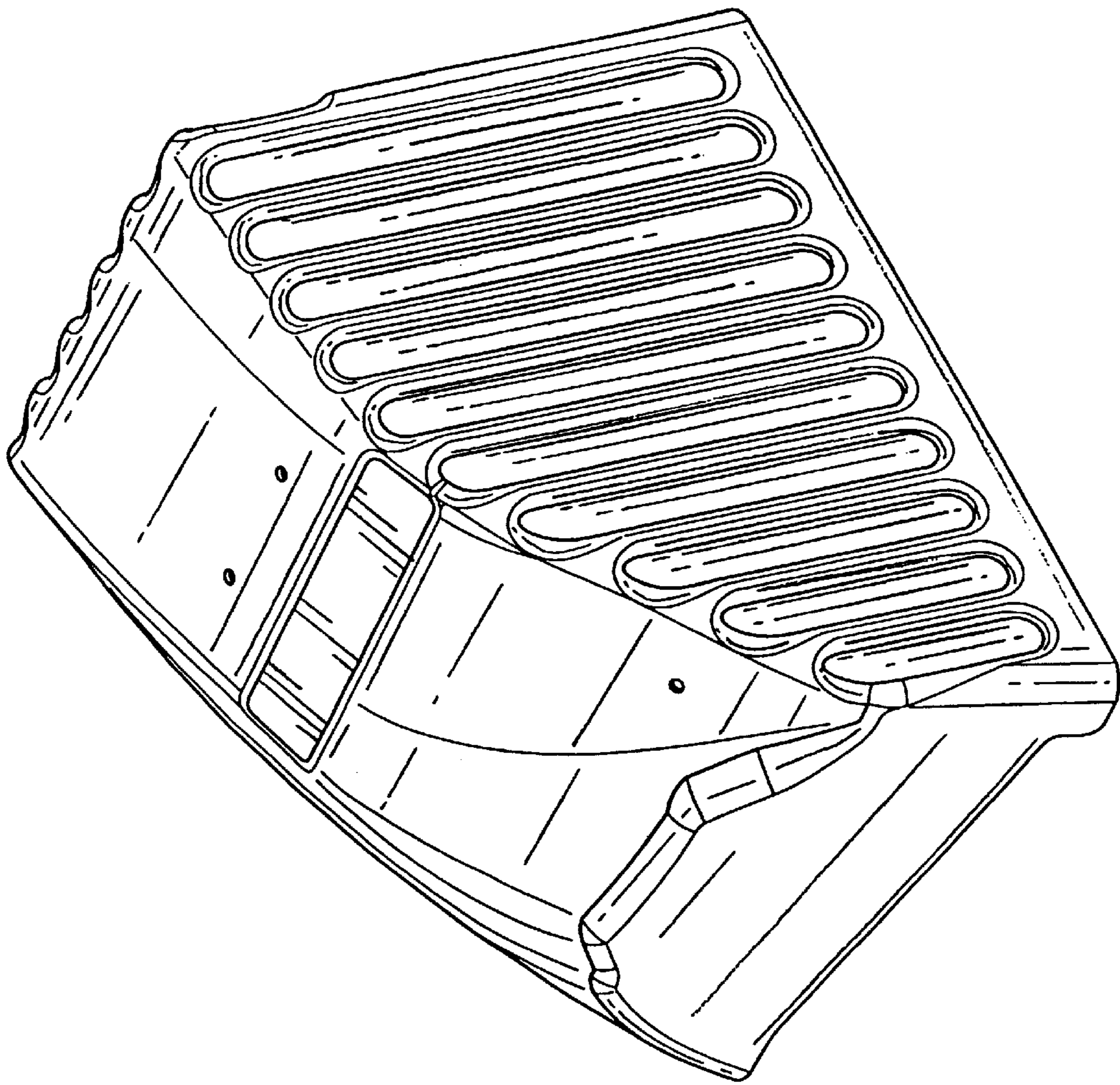

FIG. 1

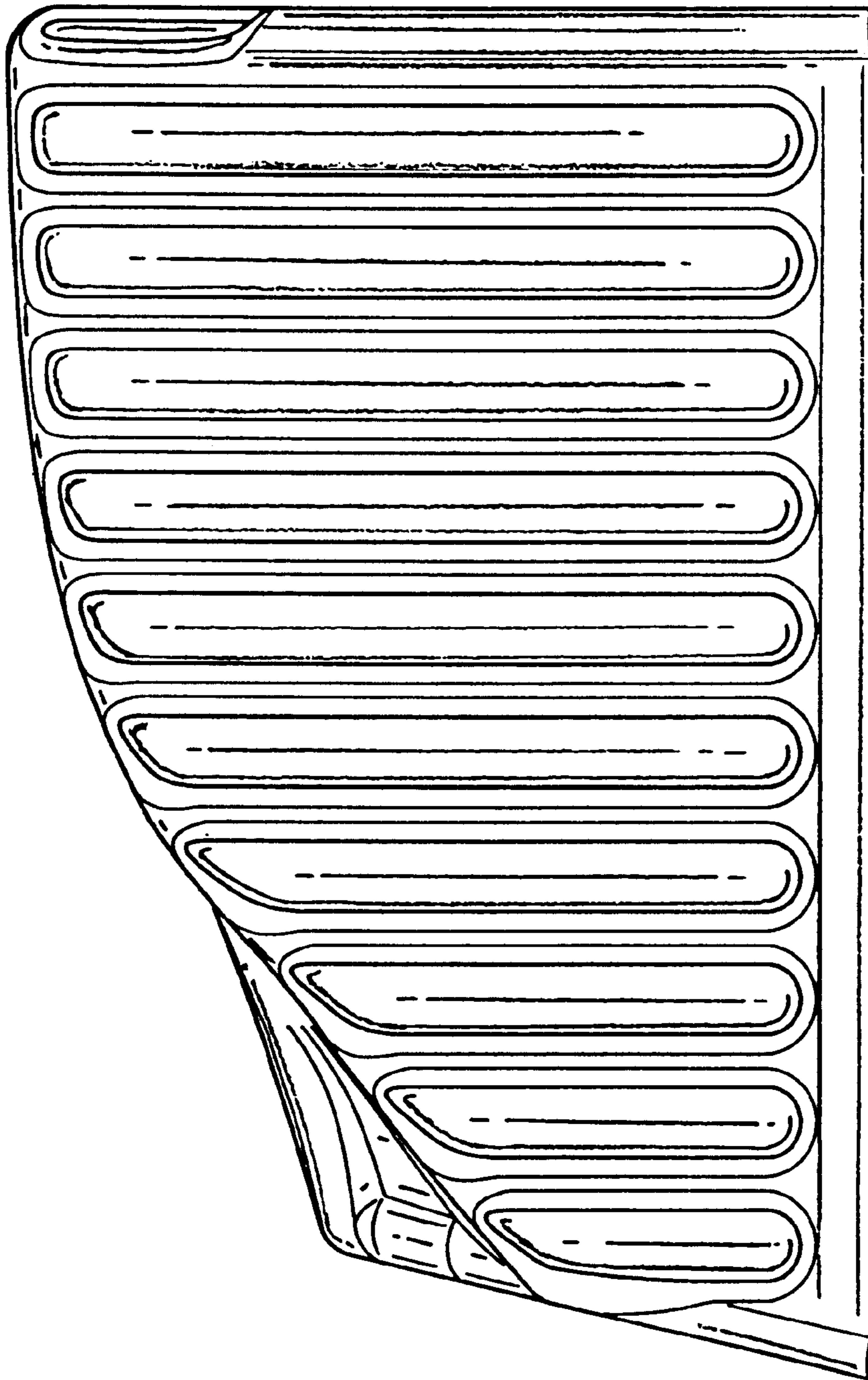

FIG. 2

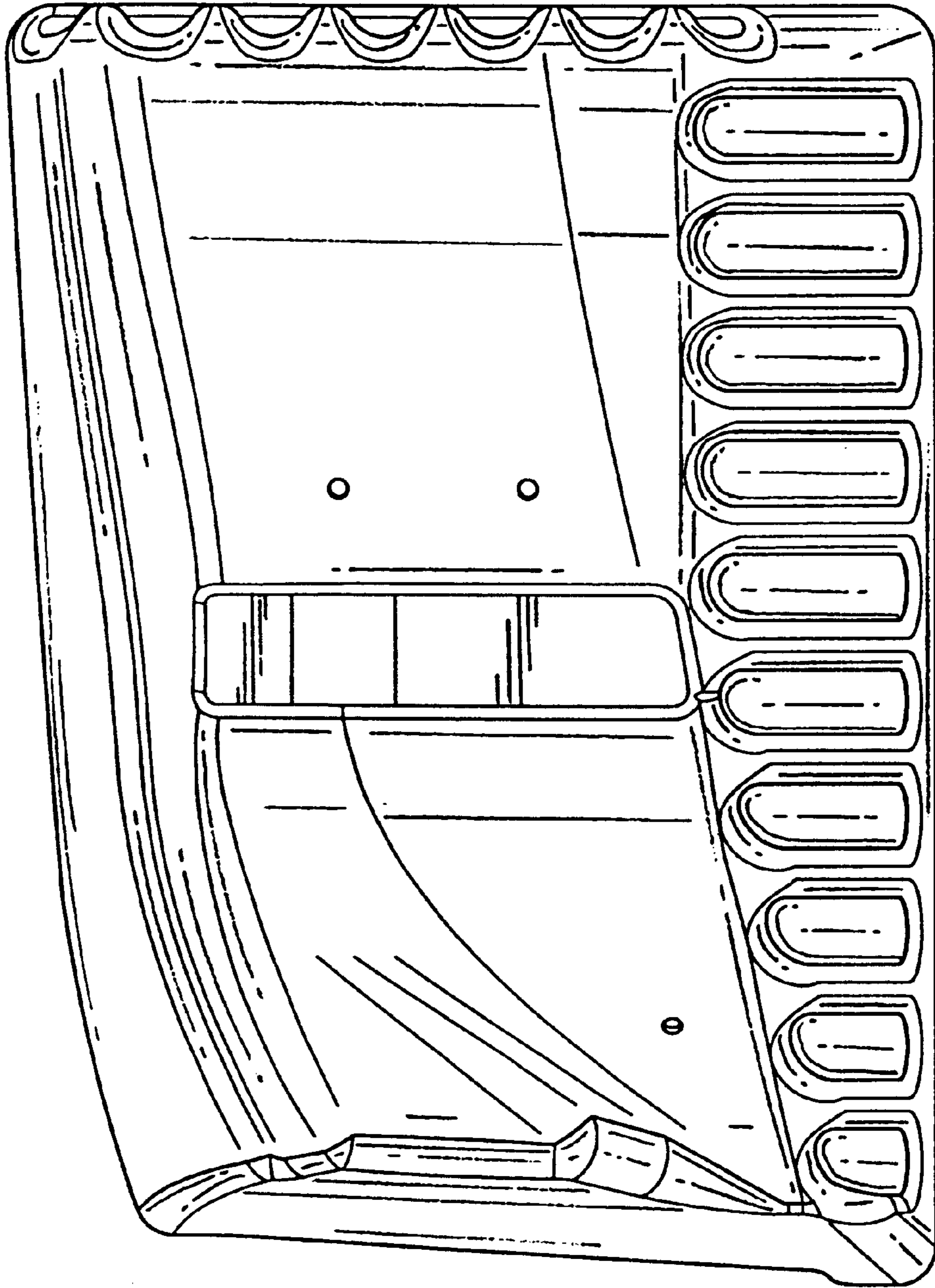

FIG. 3

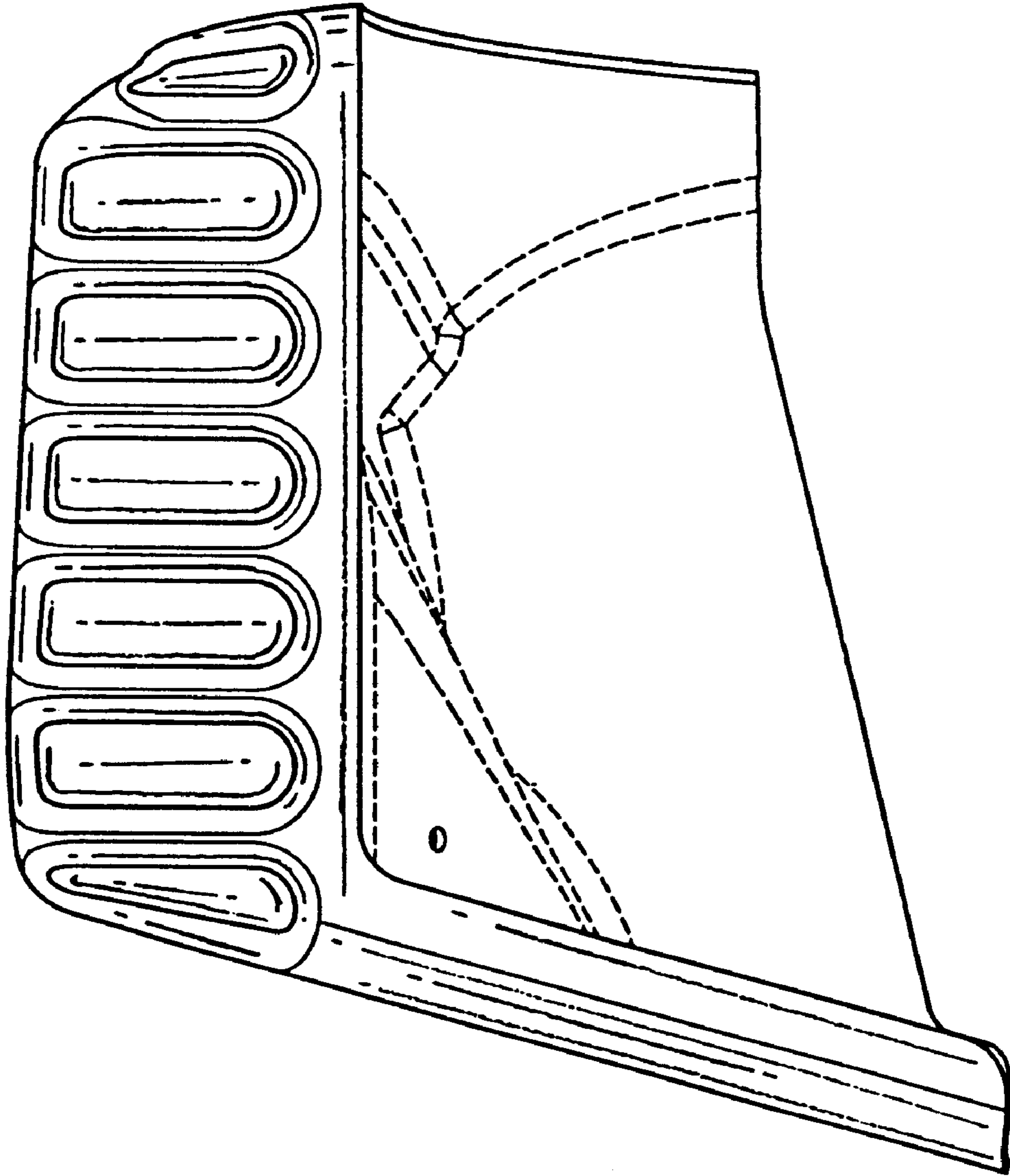

FIG. 4

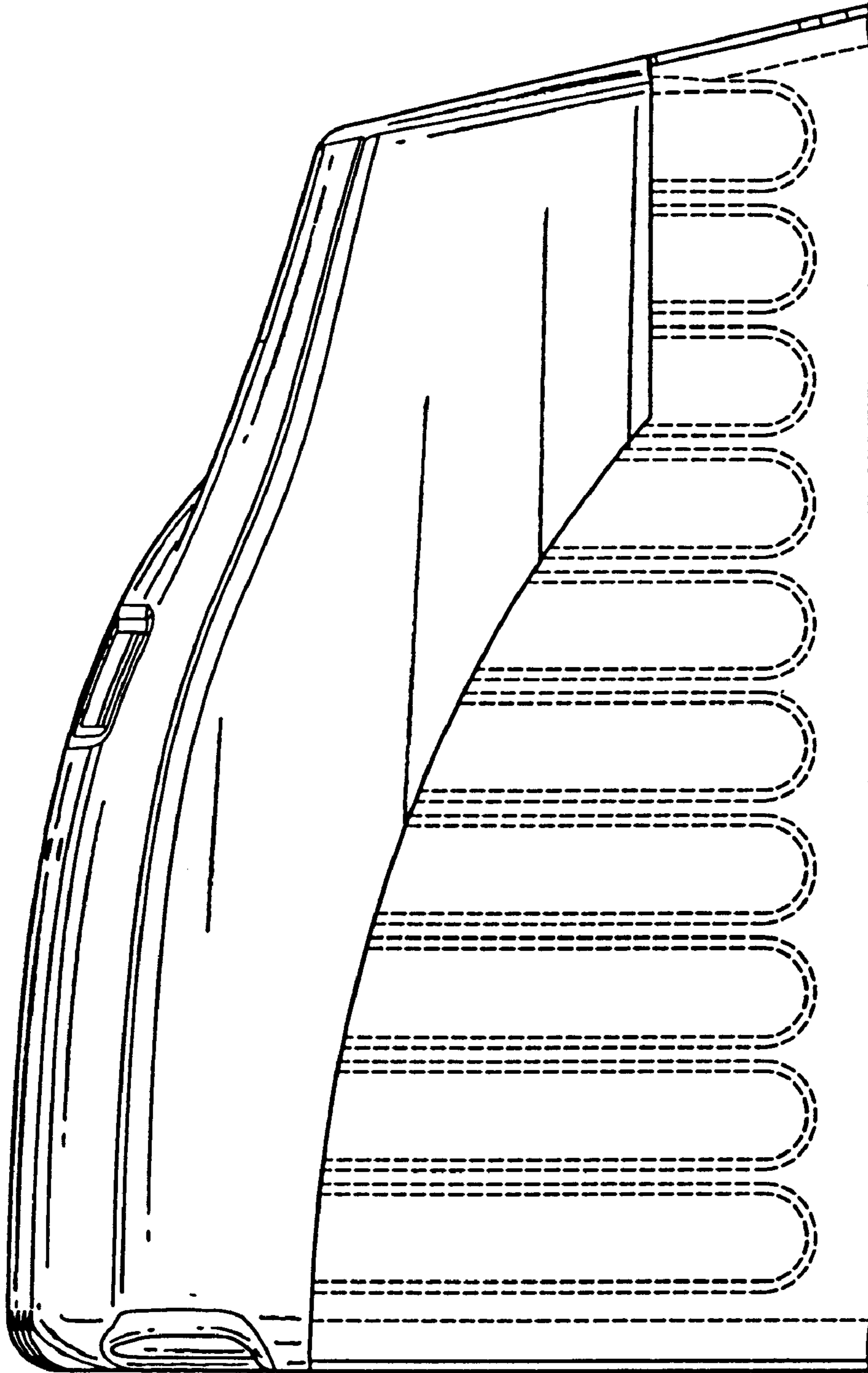

FIG. 5

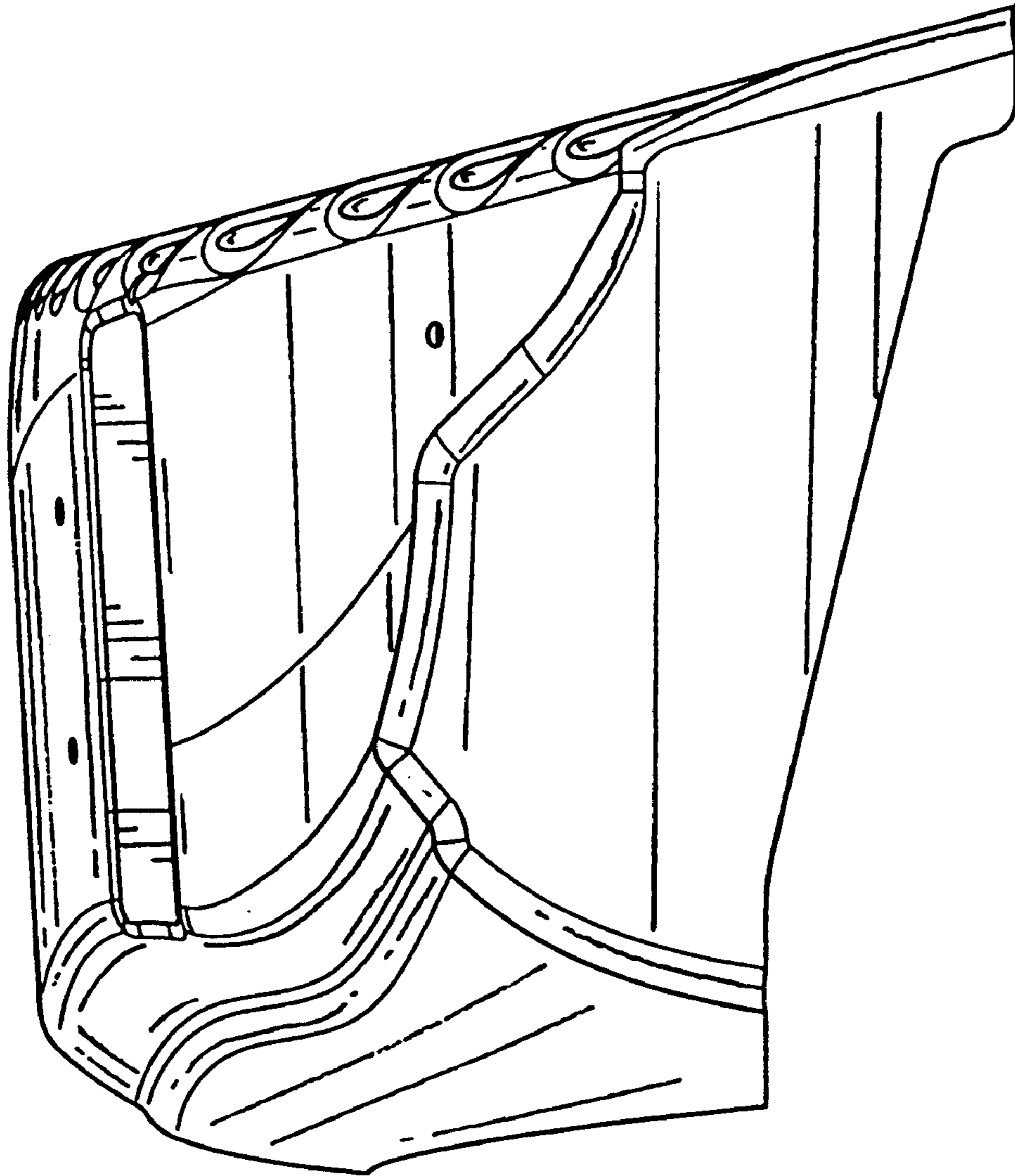

FIG. 6