



US00D453714S

(12) **United States Design Patent**
Alder

(10) **Patent No.:** **US D453,714 S**

(45) **Date of Patent:** **** Feb. 19, 2002**

(54) **MOTORBIKE FRAME**

(76) **Inventor:** **Robert Alder**, Unit 9, 6-8 Cornwall Crescent, London W11 1PP (GB)

(**) **Term:** **14 Years**

(21) **Appl. No.:** **29/131,297**

(22) **Filed:** **Oct. 19, 2000**

(30) **Foreign Application Priority Data**

Apr. 19, 2000 (GB) 2092292

(51) **LOC (7) Cl.** **12-11**

(52) **U.S. Cl.** **D12/110**

(58) **Field of Search** D12/110, 107, D12/111, 117; 280/281.1, 274, 288.1-288.3, 284; 180/219, 227, 291, 311

(56) **References Cited**

U.S. PATENT DOCUMENTS

D158,197 S * 4/1950 Kimberley D12/110
4,765,432 A * 8/1988 Odom 180/227

OTHER PUBLICATIONS

Drag Specialties FatBook, 1999, frame part No. DS-111192 on p. 601.*

“Ness Dyna Style Frame Kit” in 1999 Catalogue of Arlen Ness Inc.

Articles entitled “Y2-Khaos” in Hot Bike, Jan. 2000, pp. 58, 60, 62, 64, 66.

* cited by examiner

Primary Examiner—Alan P. Douglas

Assistant Examiner—Linda Brooks

(74) *Attorney, Agent, or Firm*—Dykema Gossett PLLC

(57) **CLAIM**

The ornamental design for a motorbike frame, as shown and described.

DESCRIPTION

FIG. 1 is a top plan view of a motorbike frame showing my new and ornamental design,

FIG. 2 is a first perspective view thereof; and,

FIG. 3 is a second perspective view thereof.

The broken lines shown form no part of the claimed design.

1 Claim, 2 Drawing Sheets

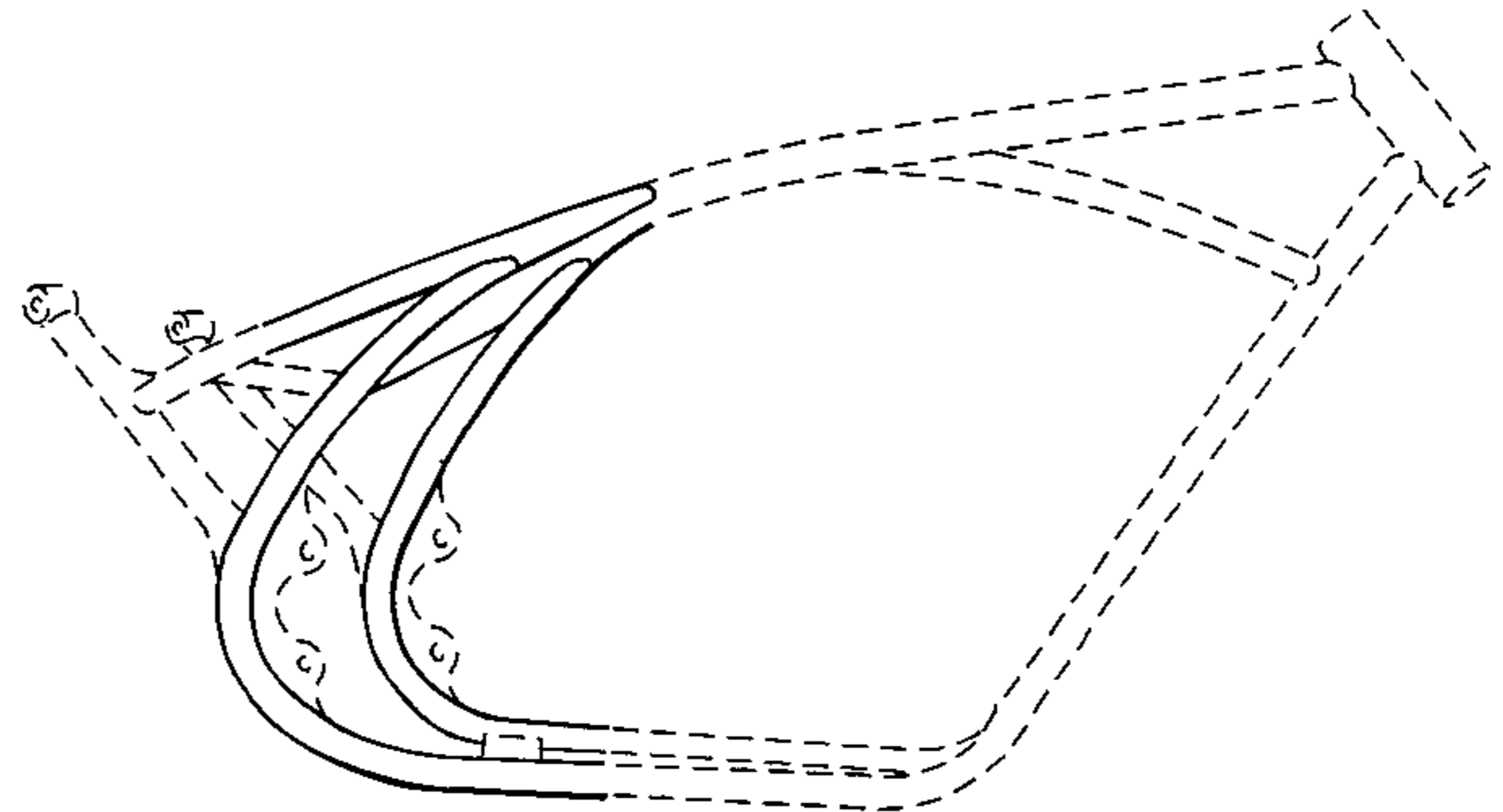
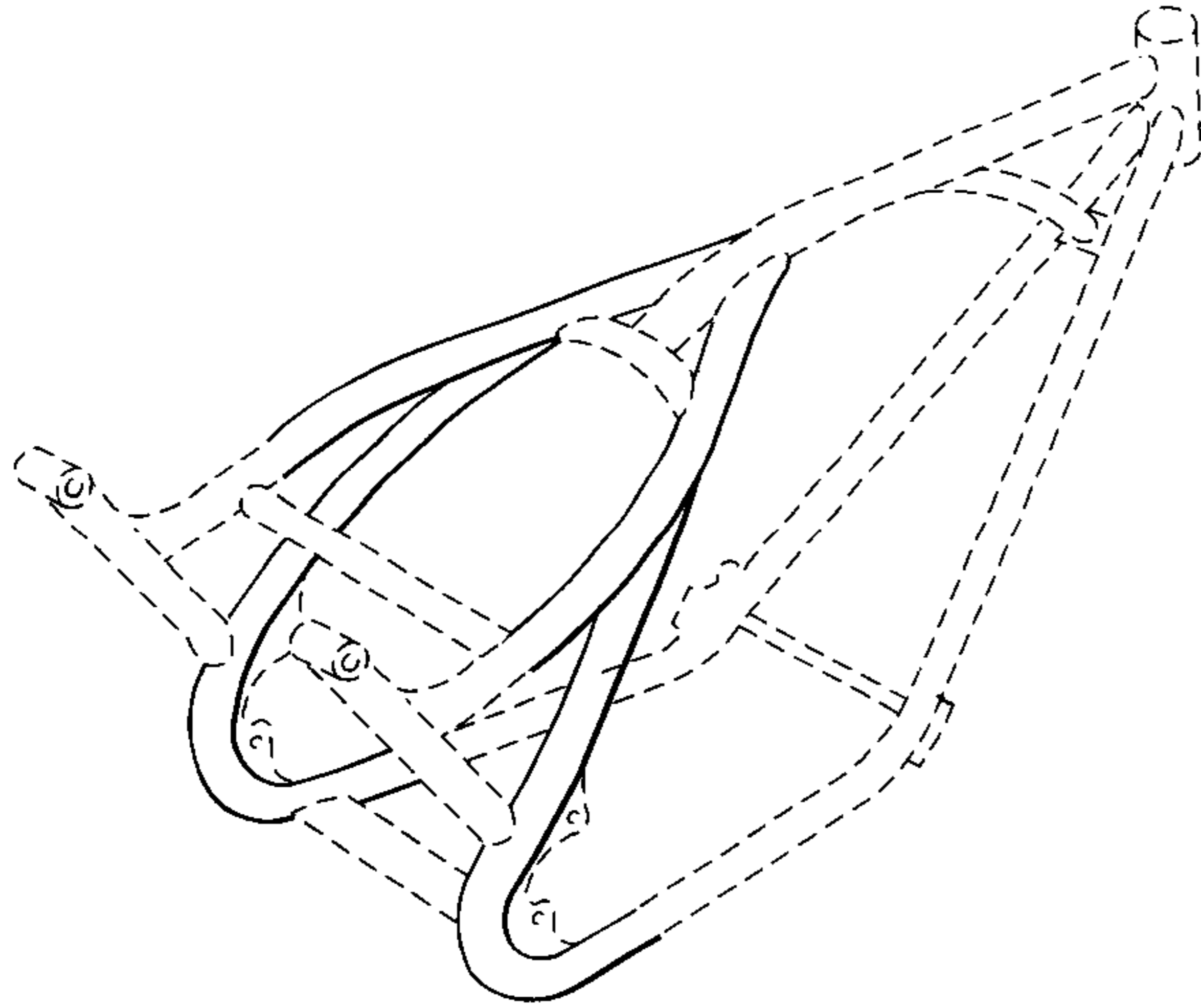

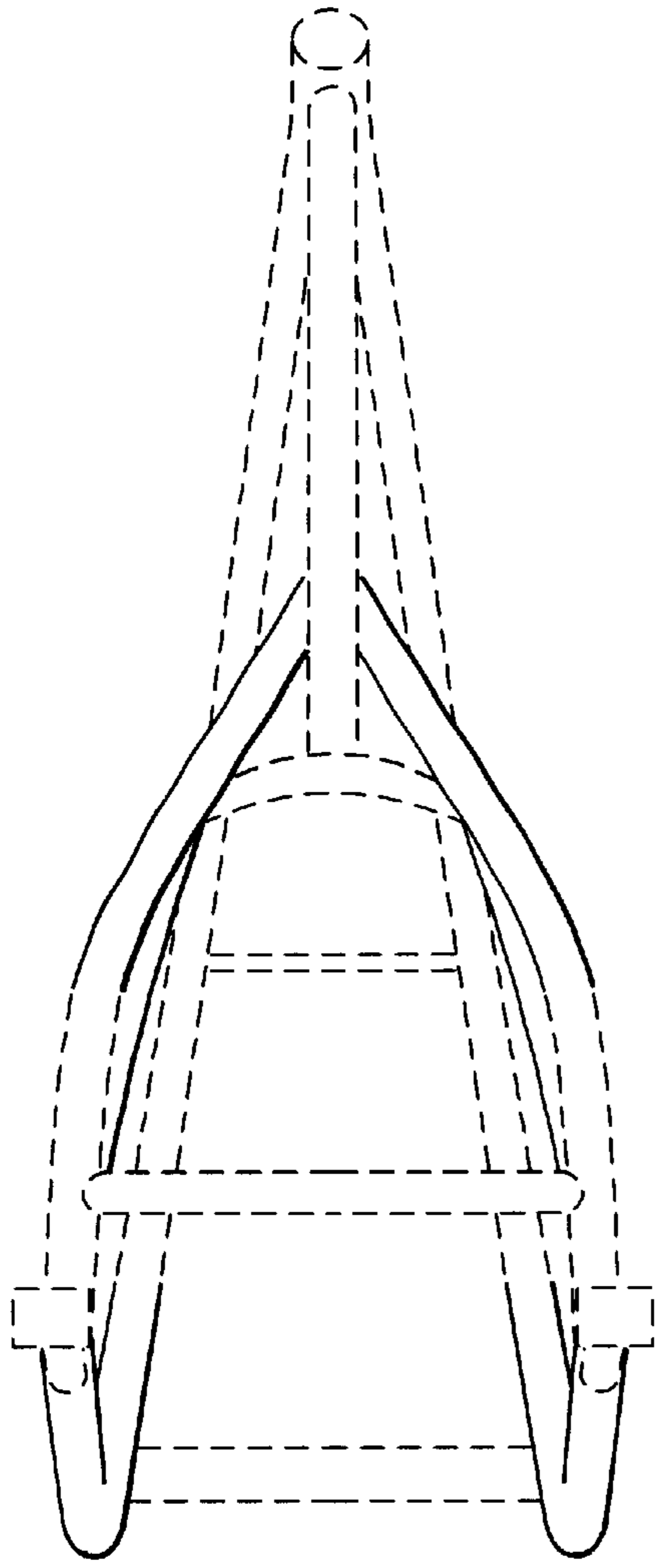

Fig. 1

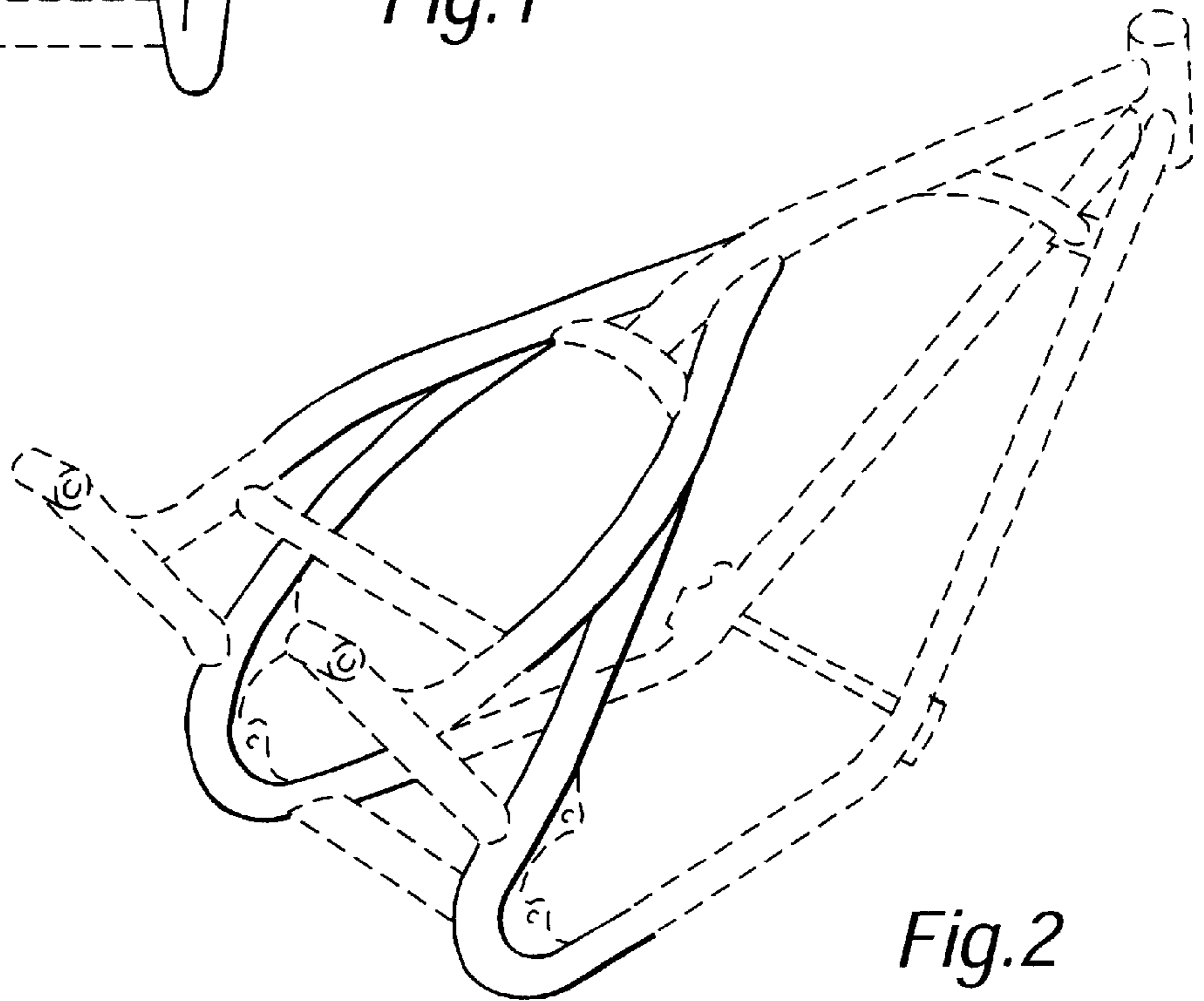

Fig. 2

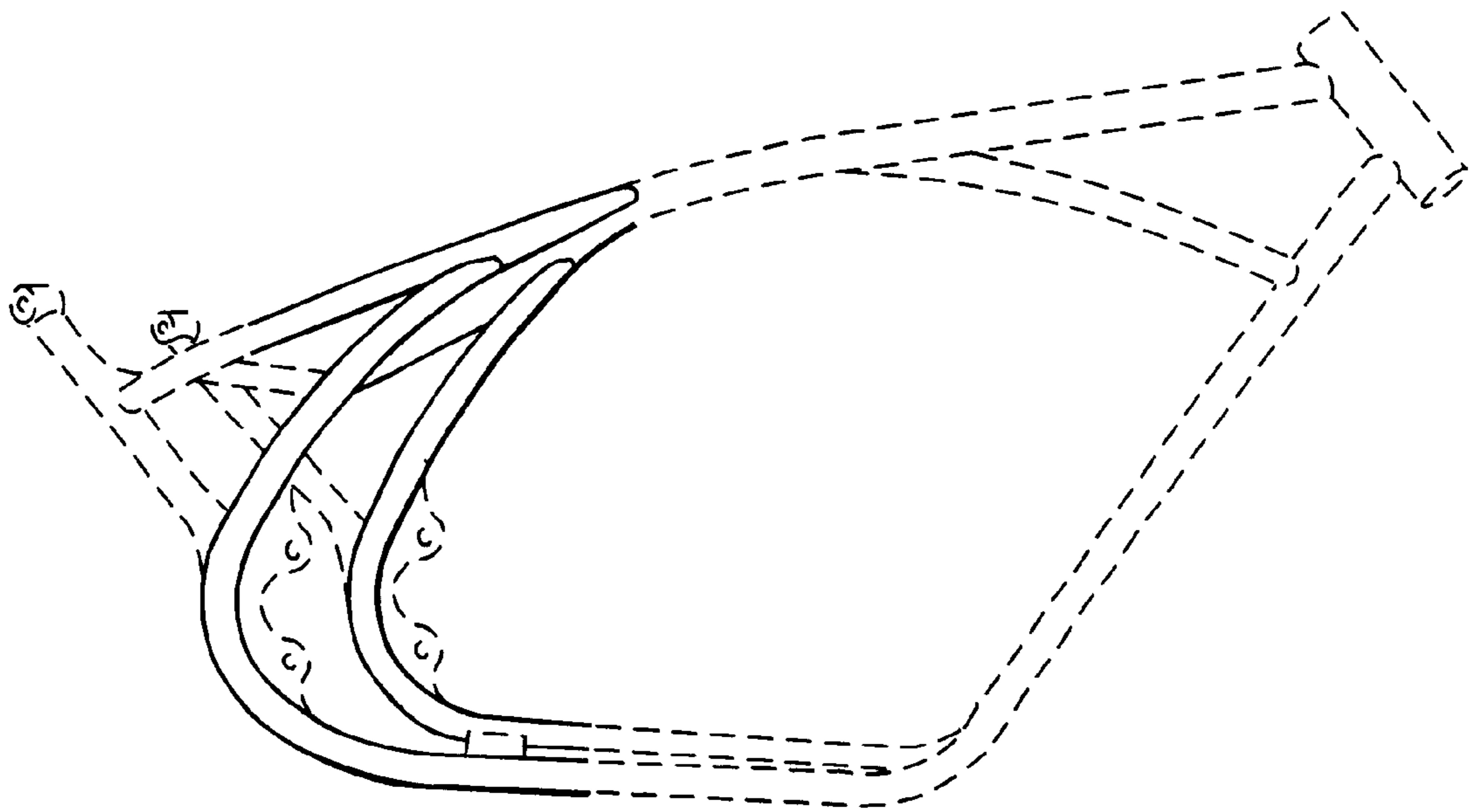

Fig.3