



US00D453669S

(12) **United States Design Patent**  
**Etter et al.**

(10) **Patent No.:** **US D453,669 S**

(45) **Date of Patent:** **\*\* Feb. 19, 2002**

(54) **BASE FOR A HAND-HELD OSCILLATING SPINDLE SANDER**

(75) Inventors: **Mark Alan Etter; John Charles Smith**, both of Jackson; **Brent Edward Stafford**, McMoresville; **Leslie Daily Gist**, Jackson, all of TN (US)

(73) Assignee: **Porter-Cable/Delta**, Jackson, TN (US)

(\*\*) Term: **14 Years**

(21) Appl. No.: **29/134,276**

(22) Filed: **Dec. 19, 2000**

**Related U.S. Application Data**

(63) Continuation-in-part of application No. 09/731,796, filed on Dec. 8, 2000.

(51) **LOC (7) Cl.** ..... **08-01**

(52) **U.S. Cl.** ..... **D8/62**

(58) **Field of Search** ..... D8/61, 62, 63, D8/64, 66, 67, 68, 69, 70; 30/392, 394; 310/50; 408/124; 451/344, 356, 357, 358, 359

(56) **References Cited**

**U.S. PATENT DOCUMENTS**

- 3,303,661 A \* 2/1967 Kane ..... D8/64
- D207,695 S \* 5/1967 Gresens et al. .... D8/64
- 3,339,598 A \* 9/1967 Frostad ..... D8/64
- D242,689 S \* 12/1976 Notaras et al. .... D8/70
- 4,213,242 A \* 7/1980 Partington ..... 30/392

- D262,472 S \* 12/1981 Wildman ..... D8/64
- D300,716 S \* 4/1989 Clowers ..... D8/69
- 5,038,481 A \* 8/1991 Smith ..... 30/392
- 5,678,292 A 10/1997 Kimbel et al. .... 29/76.4
- D413,243 S \* 8/1999 Robson ..... D8/64
- 5,957,765 A 9/1999 Kimbel et al. .... 451/358
- D440,474 S \* 4/2001 Heun ..... D8/64

\* cited by examiner

*Primary Examiner*—Doris V. Coles

*Assistant Examiner*—Elizabeth A. Albert

(74) *Attorney, Agent, or Firm*—Hunton & Williams

(57) **CLAIM**

The ornamental design for a base for a hand-held oscillating spindle sander, as shown and described.

**DESCRIPTION**

This application is related by subject matter to application Ser. No. 29/134,282, entitled "Hand-held Oscillating Spindle Sander".

FIG. 1 is an isometric view of the base for a hand-held oscillating spindle sander;

FIG. 2 is a side view thereof;

FIG. 3 is a front view thereof;

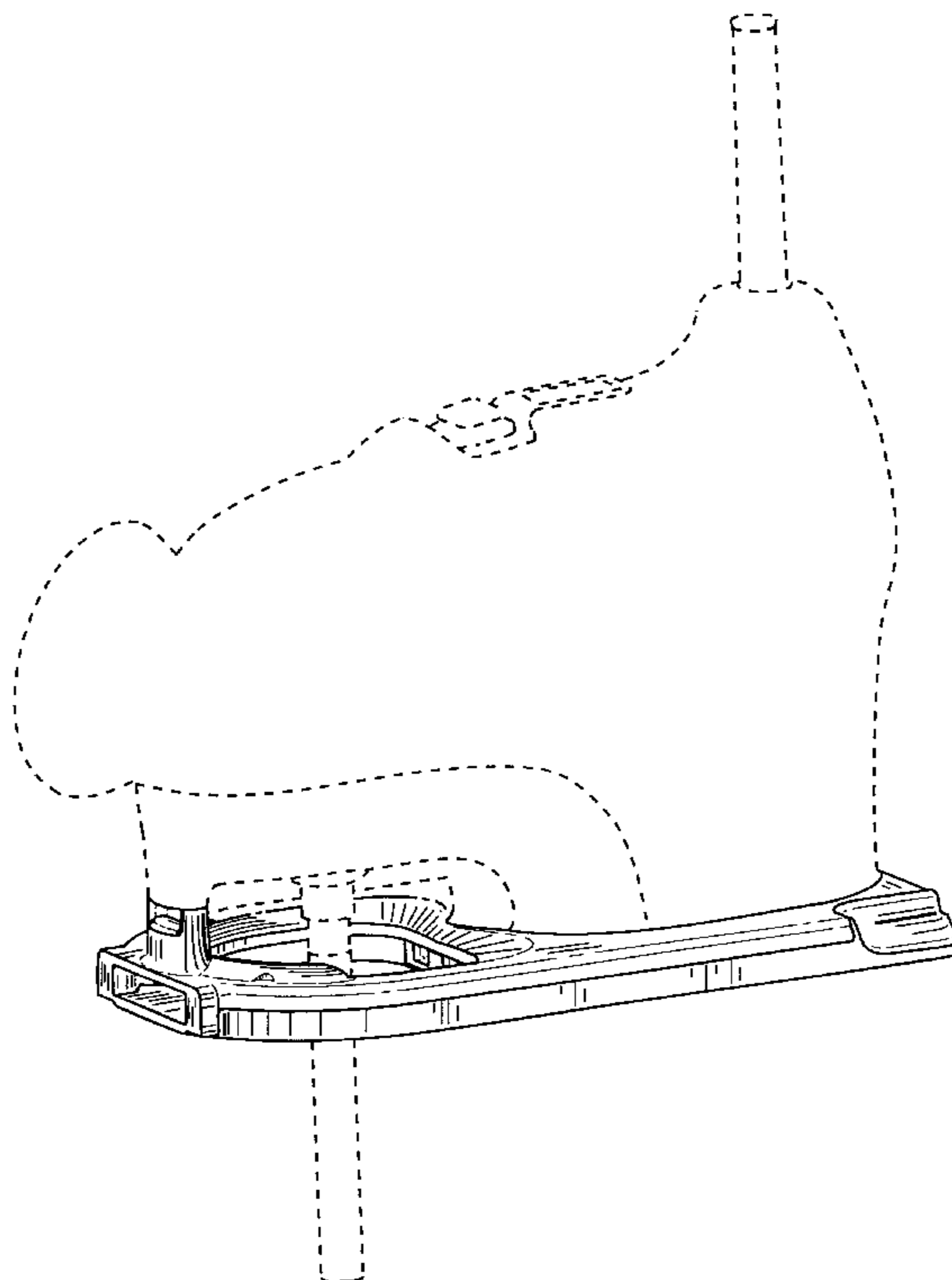
FIG. 4 is a back view thereof;

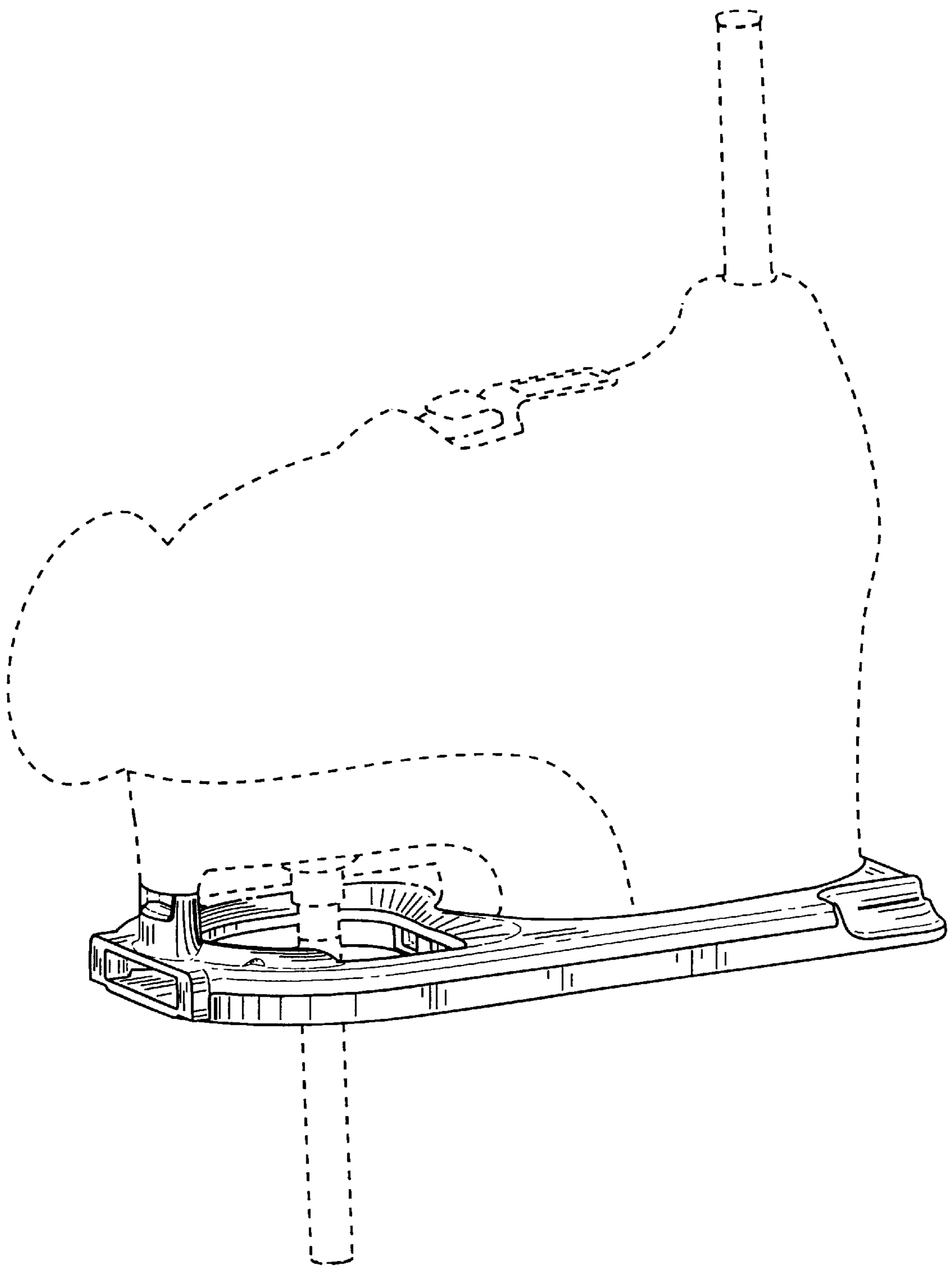
FIG. 5 is a top view thereof; and,

FIG. 6 is a bottom view thereof.

Only one side view is shown as each side view is the mirror image of the other. The broken line illustration of environmental structure in the figures is for illustrative purposes only and forms no part of the claimed design.

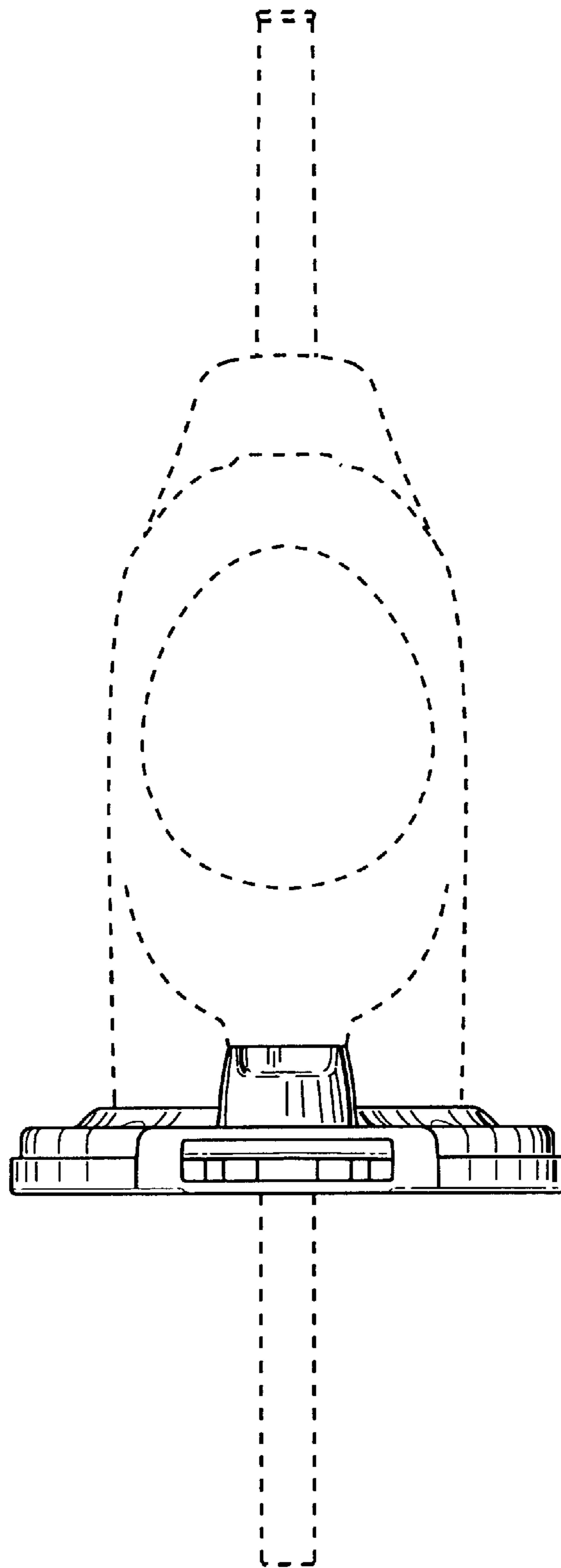
**1 Claim, 6 Drawing Sheets**



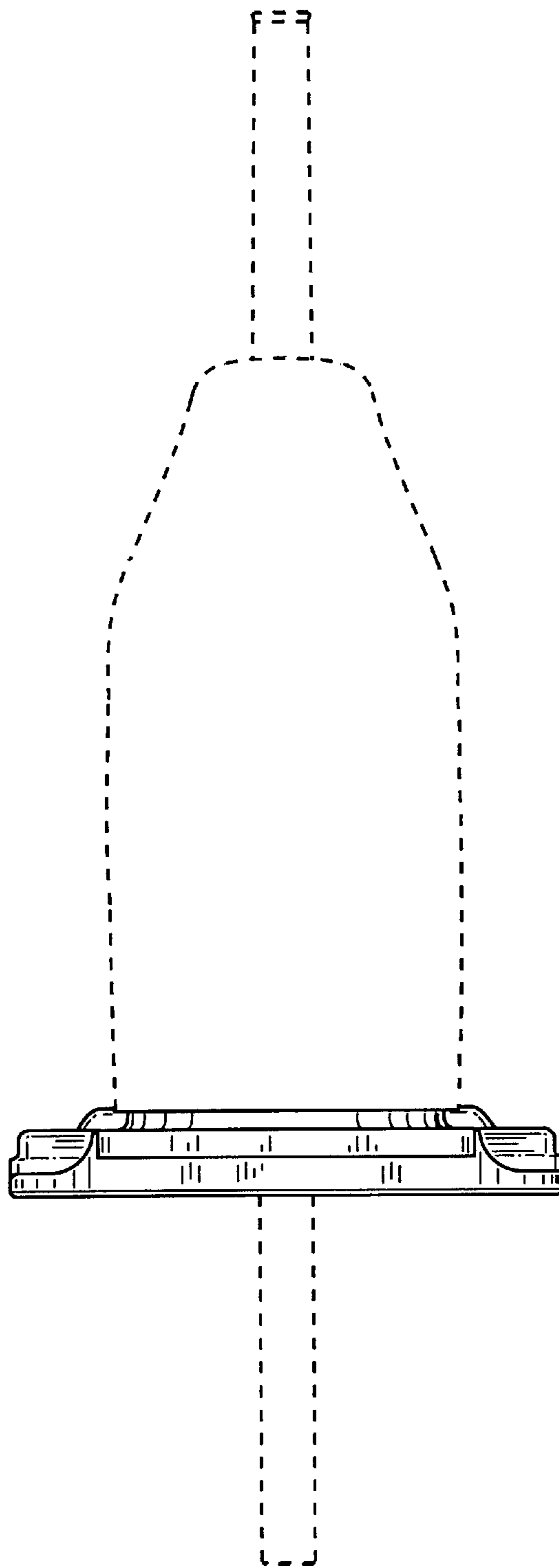


**FIG. 1**

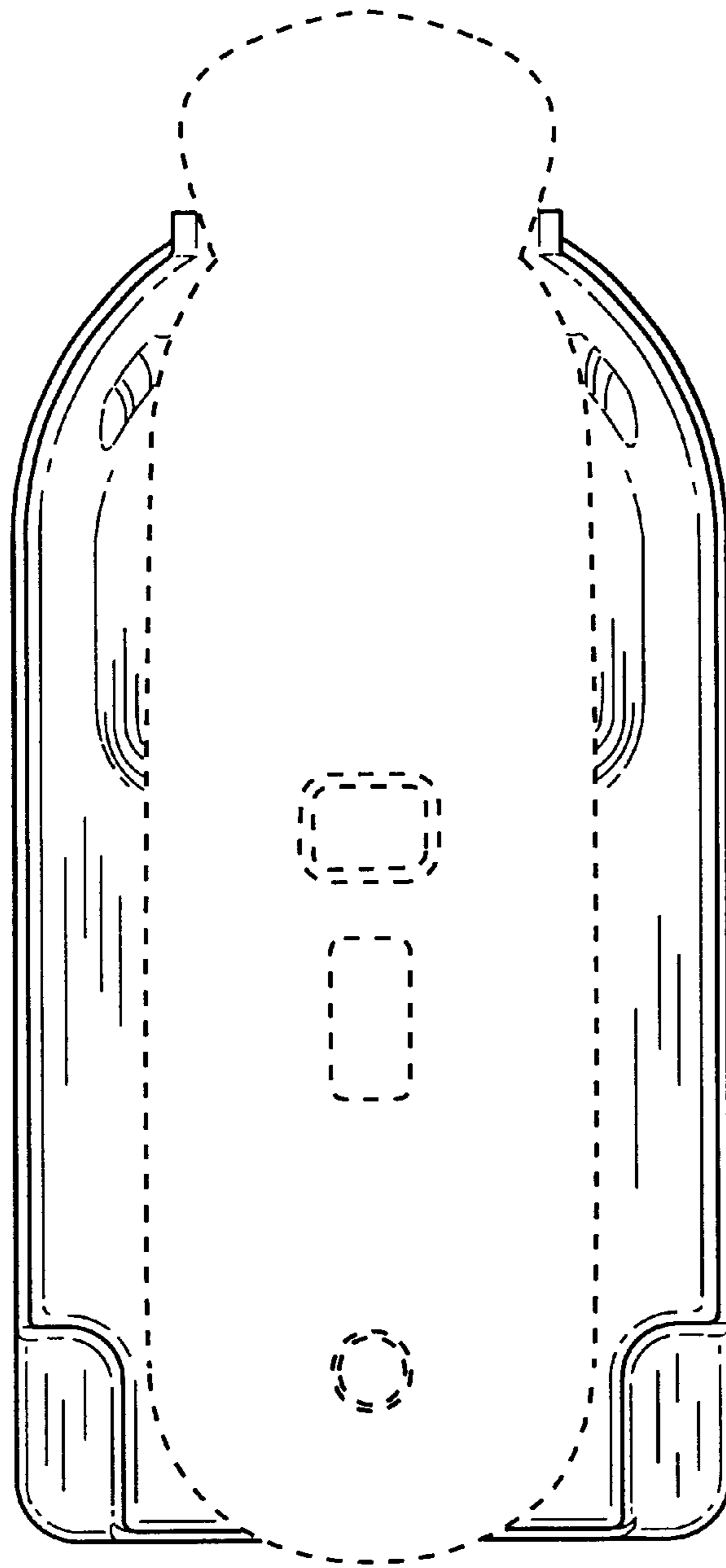




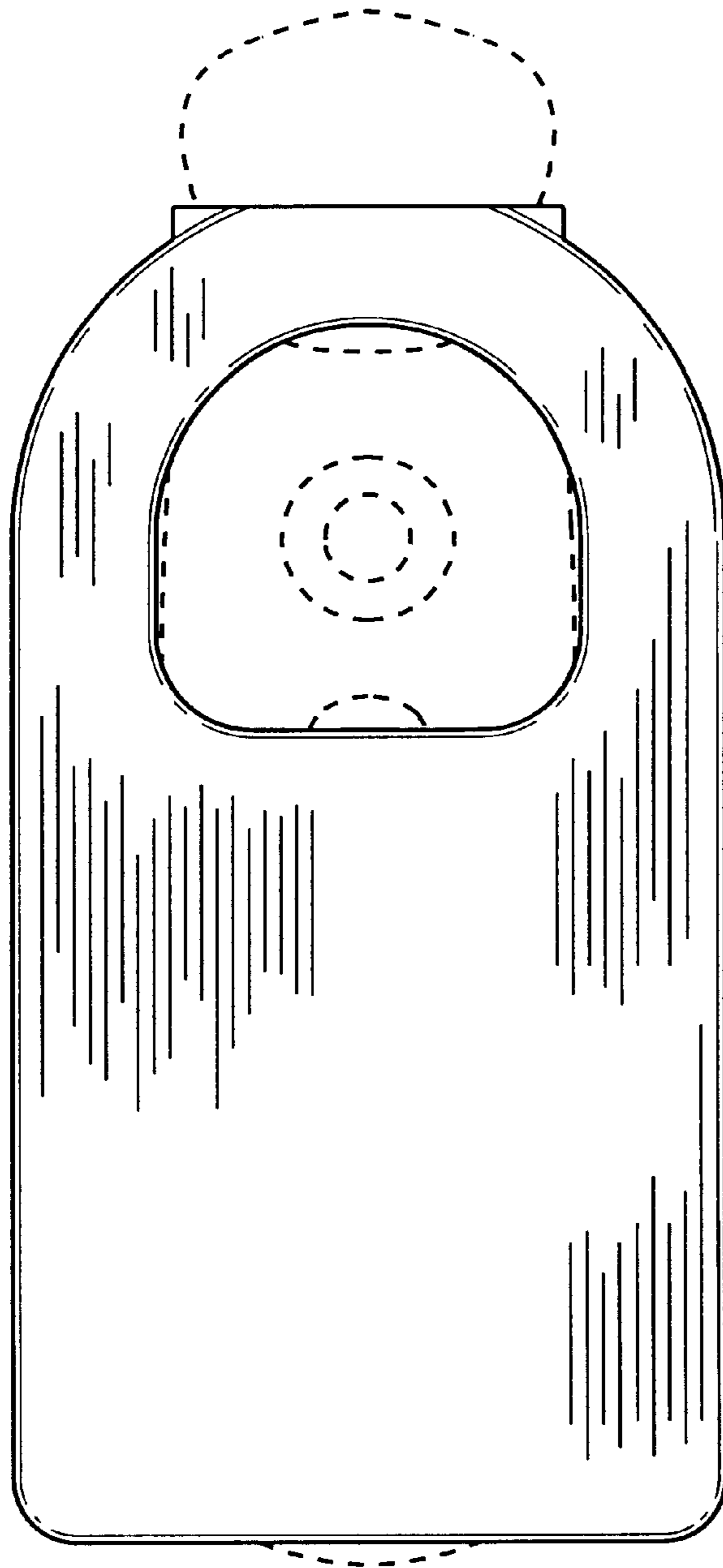
**FIG. 3**



**FIG. 4**



**FIG. 5**



**FIG. 6**