



US00D453627S

(12) **United States Design Patent**  
**Holmes et al.**

(10) **Patent No.:** **US D453,627 S**

(45) **Date of Patent:** **\*\* Feb. 19, 2002**

(54) **BOTTLE AND BRUSH COMBINATION**

(75) **Inventors:** **Richard A. Holmes; William H. Houghton**, both of Akron; **Paul G. Ouillette**, Stow; **John P. Cichello, II**, Wooster, all of OH (US)

(73) **Assignee:** **Joseph S. Kanfer**, Richfield, OH (US)

(\*\*) **Term:** **14 Years**

(21) **Appl. No.:** **29/119,159**

(22) **Filed:** **Feb. 25, 2000**

(51) **LOC (7) Cl.** ..... **04-01**

(52) **U.S. Cl.** ..... **D4/116; D9/338; D9/531**

(58) **Field of Search** ..... **D4/114, 116, 130; D9/338, 527, 528, 531; 401/118, 123, 137, 139**

(56) **References Cited**

**U.S. PATENT DOCUMENTS**

716,740 A	12/1902	Muller, et al.	
864,676 A	8/1907	Nagely	
2,859,463 A	11/1958	Hirsch	
3,354,492 A	11/1967	Baumgartner	
3,565,541 A	* 2/1971	Vallis	401/137
3,722,021 A	* 3/1973	Brainerd et al.	401/139 X
3,754,831 A	8/1973	Hutter	401/139
3,843,991 A	10/1974	Vallis	15/167.3
4,420,853 A	12/1983	Gilman et al.	15/111
4,480,351 A	11/1984	Koffler	15/187
4,618,443 A	10/1986	Jude	252/92

4,757,571 A	7/1988	Young	15/167.3
D338,297 S	8/1993	Singarella	D32/42
D346,332 S	4/1994	Kanfer et al.	D9/531
5,299,876 A	4/1994	Singaarella	401/139
5,312,197 A	5/1994	Abramson	401/6
5,355,545 A	10/1994	Hoagland	15/111
5,442,829 A	8/1995	Summers	15/106
5,558,453 A	9/1996	Bell et al.	401/137
D383,001 S	9/1997	Bell et al.	D4/116
6,036,389 A	3/2000	Zima	401/137

\* cited by examiner

*Primary Examiner*—Alan P. Douglas

*Assistant Examiner*—Lavone Tabor

(74) *Attorney, Agent, or Firm*—Reese Taylor

(57) **CLAIM**

The ornamental design for a bottle and brush combination, as shown and described.

**DESCRIPTION**

FIG. 1 is an elevational view showing our new bottle and brush combination;

FIG. 2 is an elevational view taken from the rear of FIG. 1;

FIG. 3 is a side elevational view taken from the left of FIG. 1;

FIG. 4 is a side elevational view taken from the right of FIG. 1;

FIG. 5 is a top plan view thereof; and,

FIG. 6 is a bottom plan view thereof.

The bristles are partially shown in FIGS. 1, 2, 5 and 6 for ease of illustration.

**1 Claim, 5 Drawing Sheets**

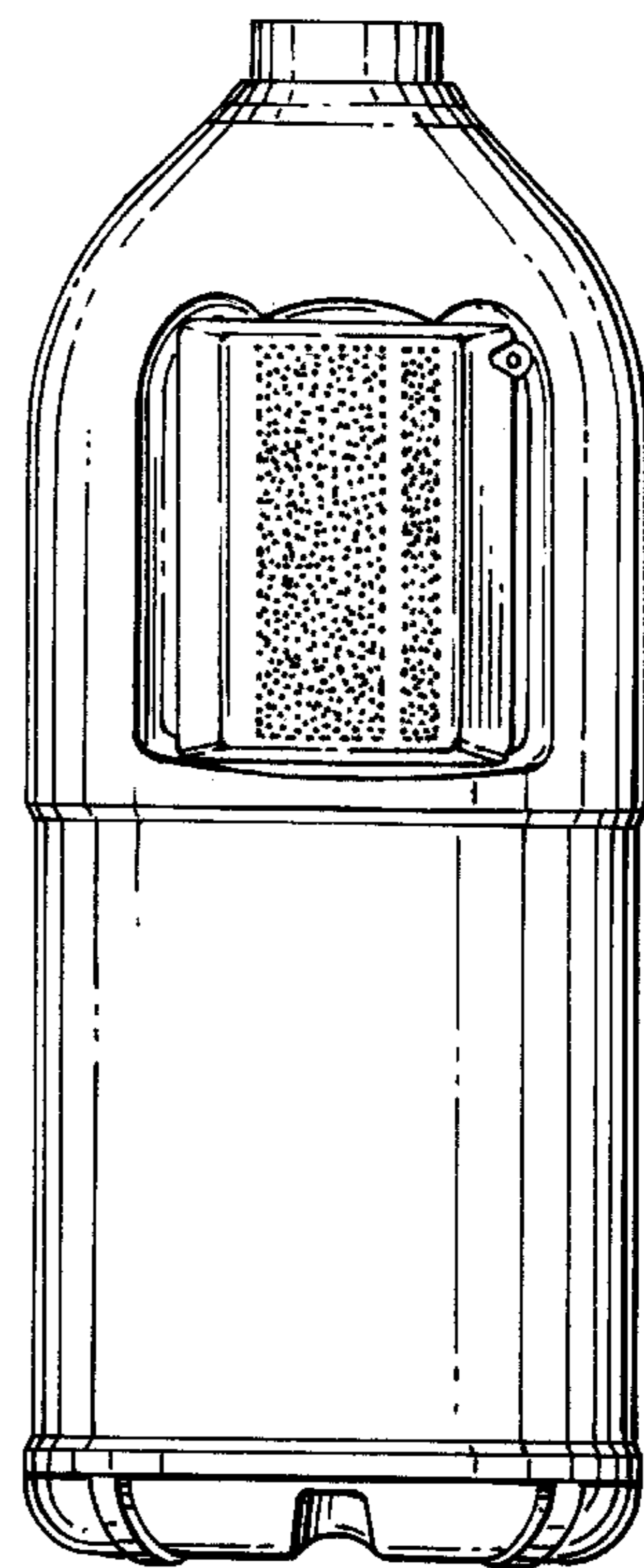
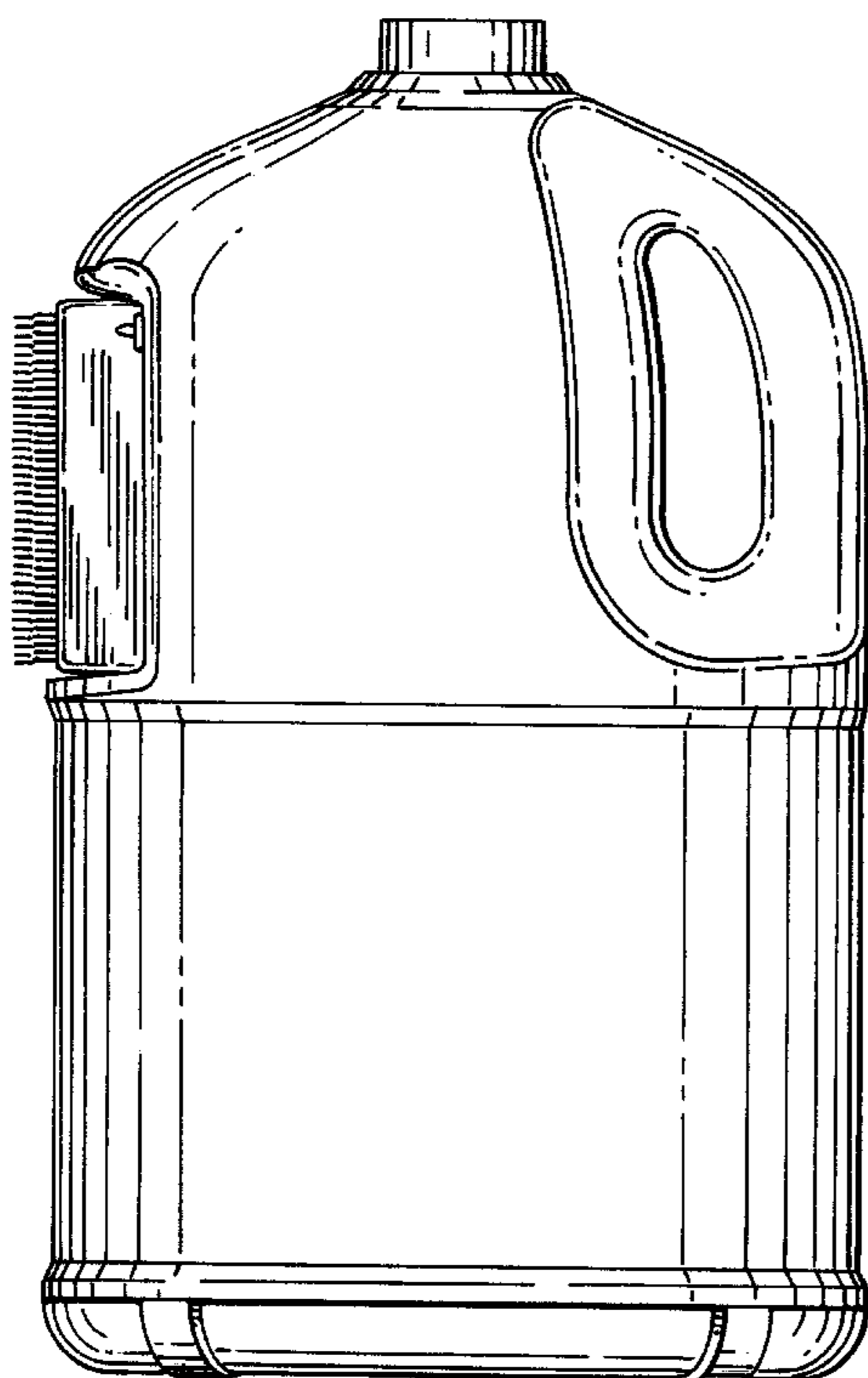

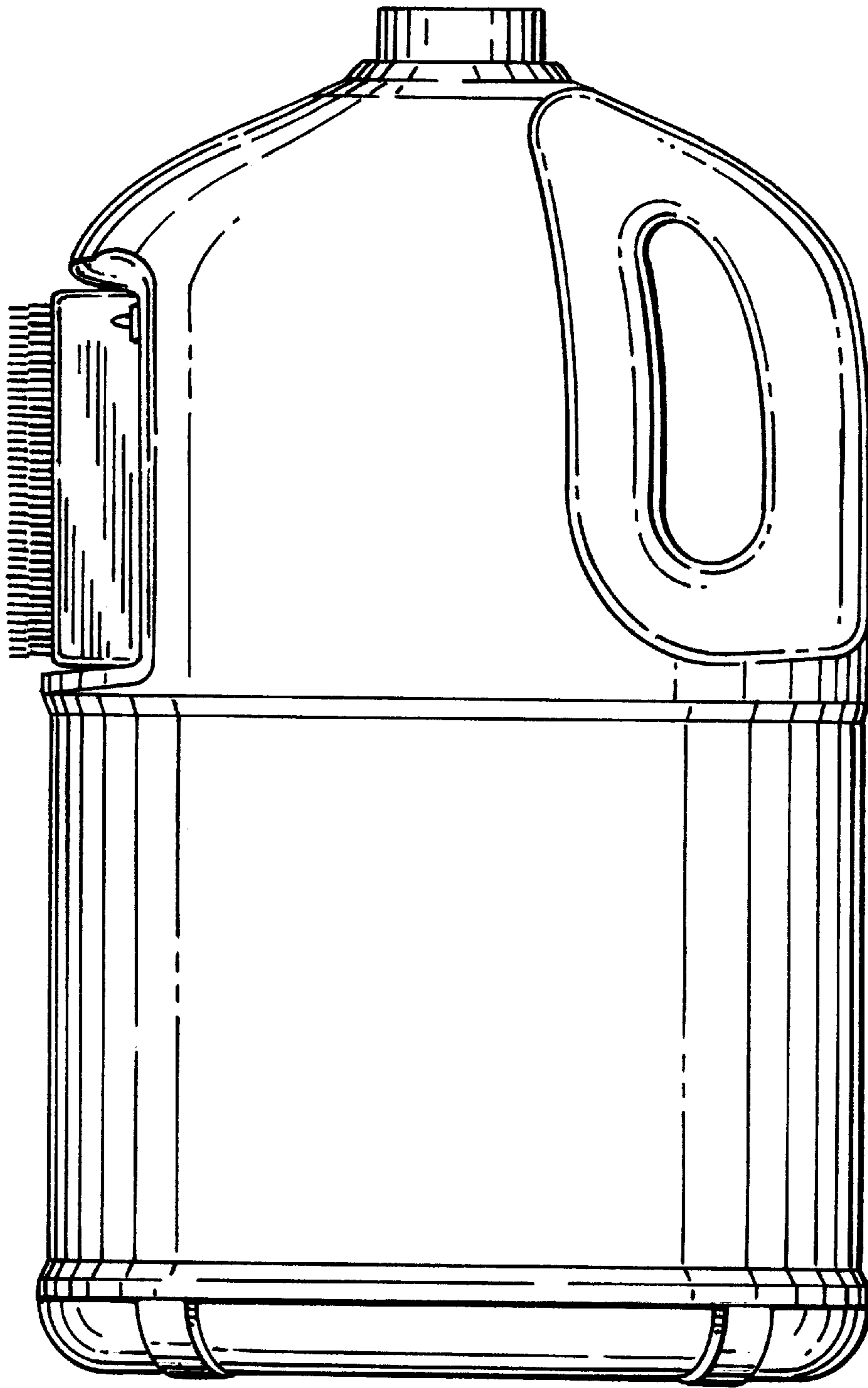

*FIG. 1*

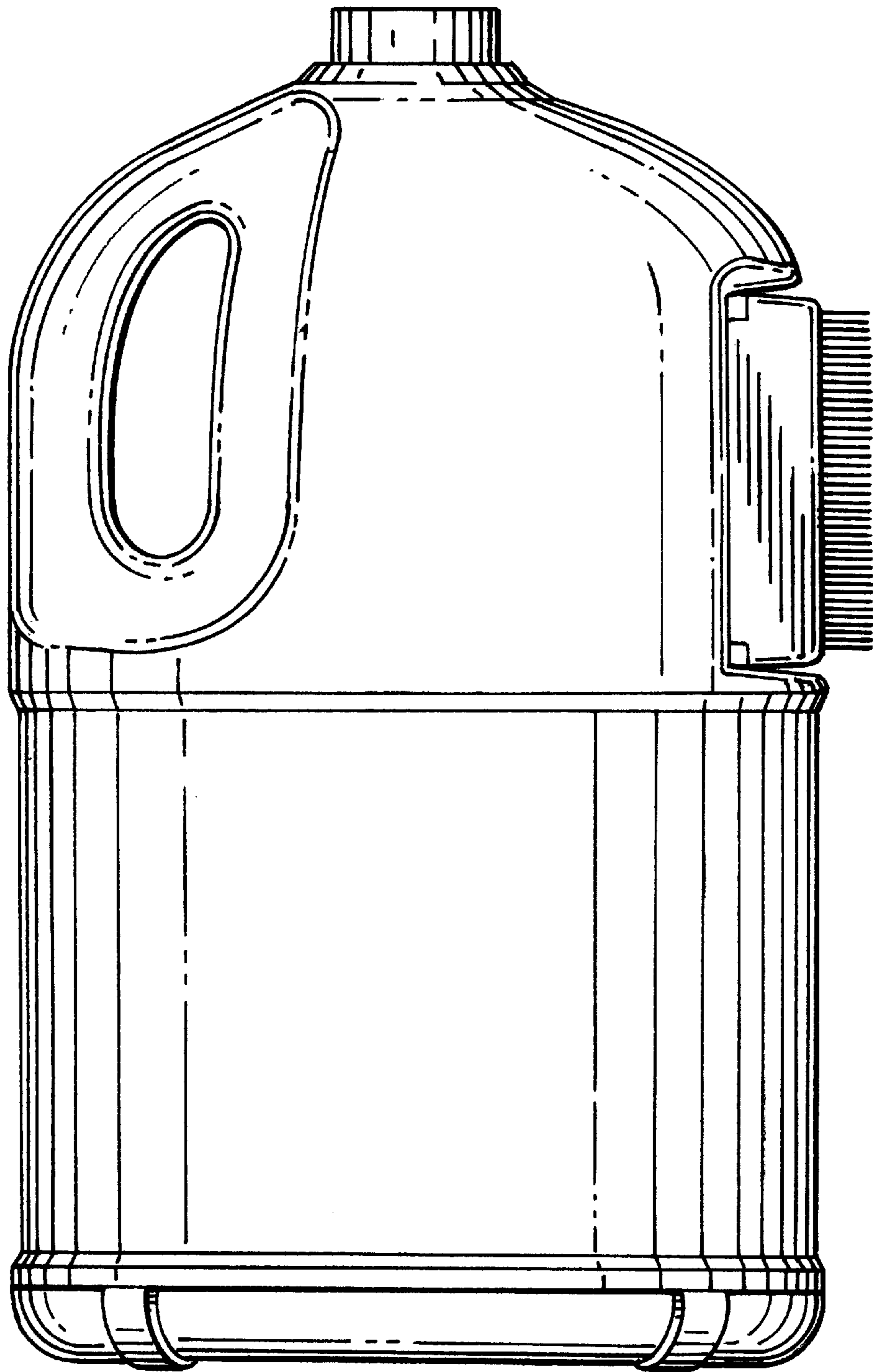

*FIG. 2*

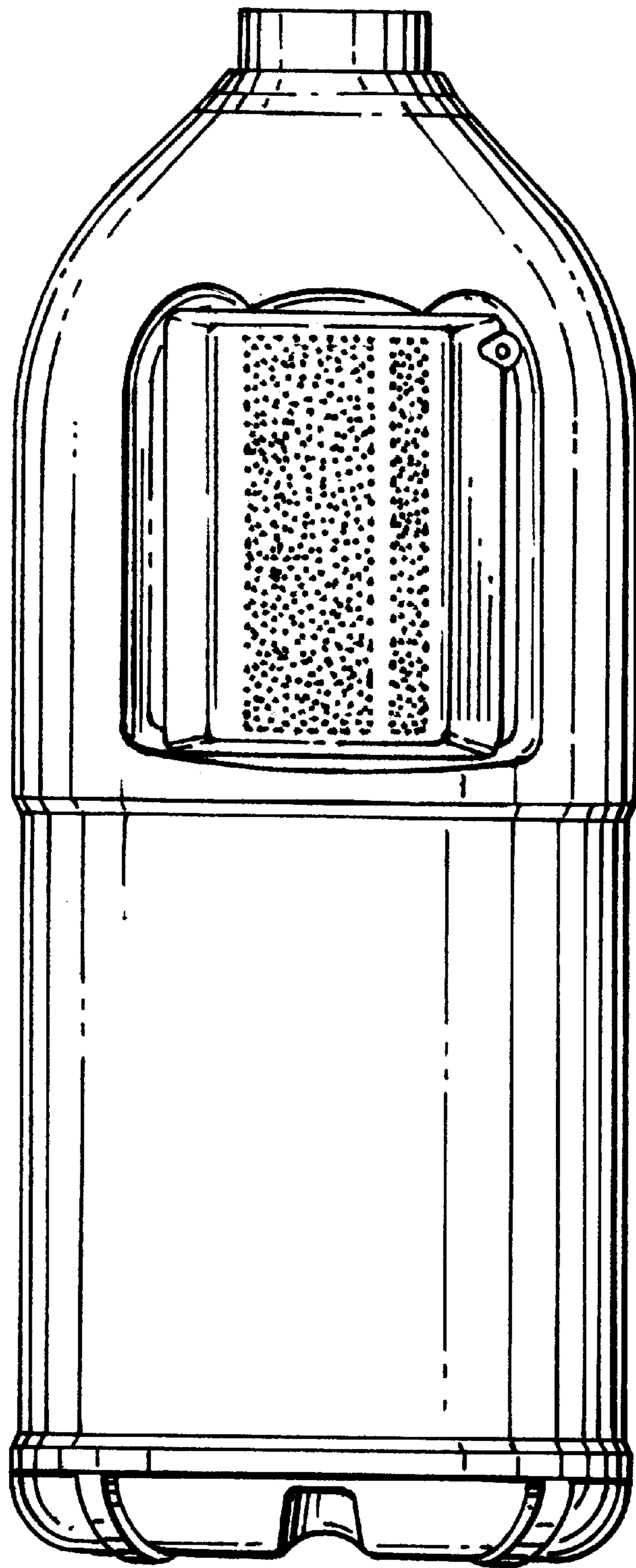
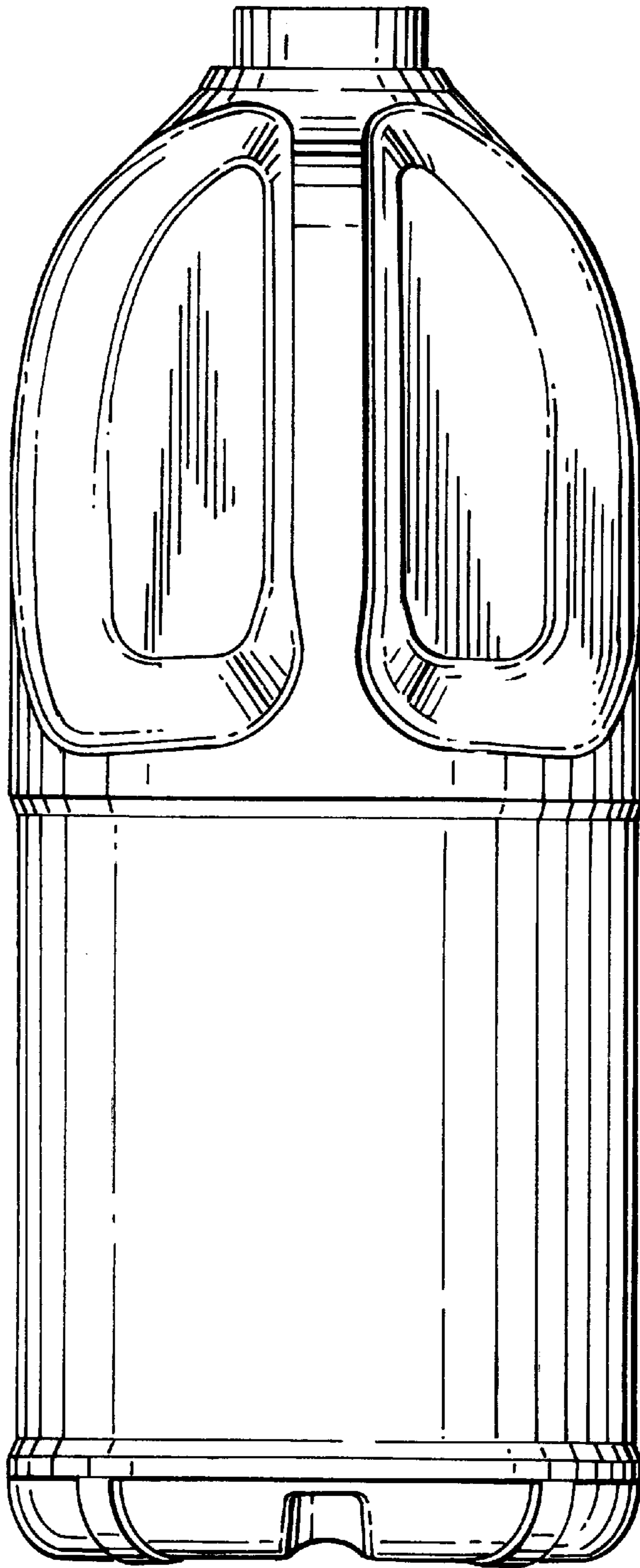
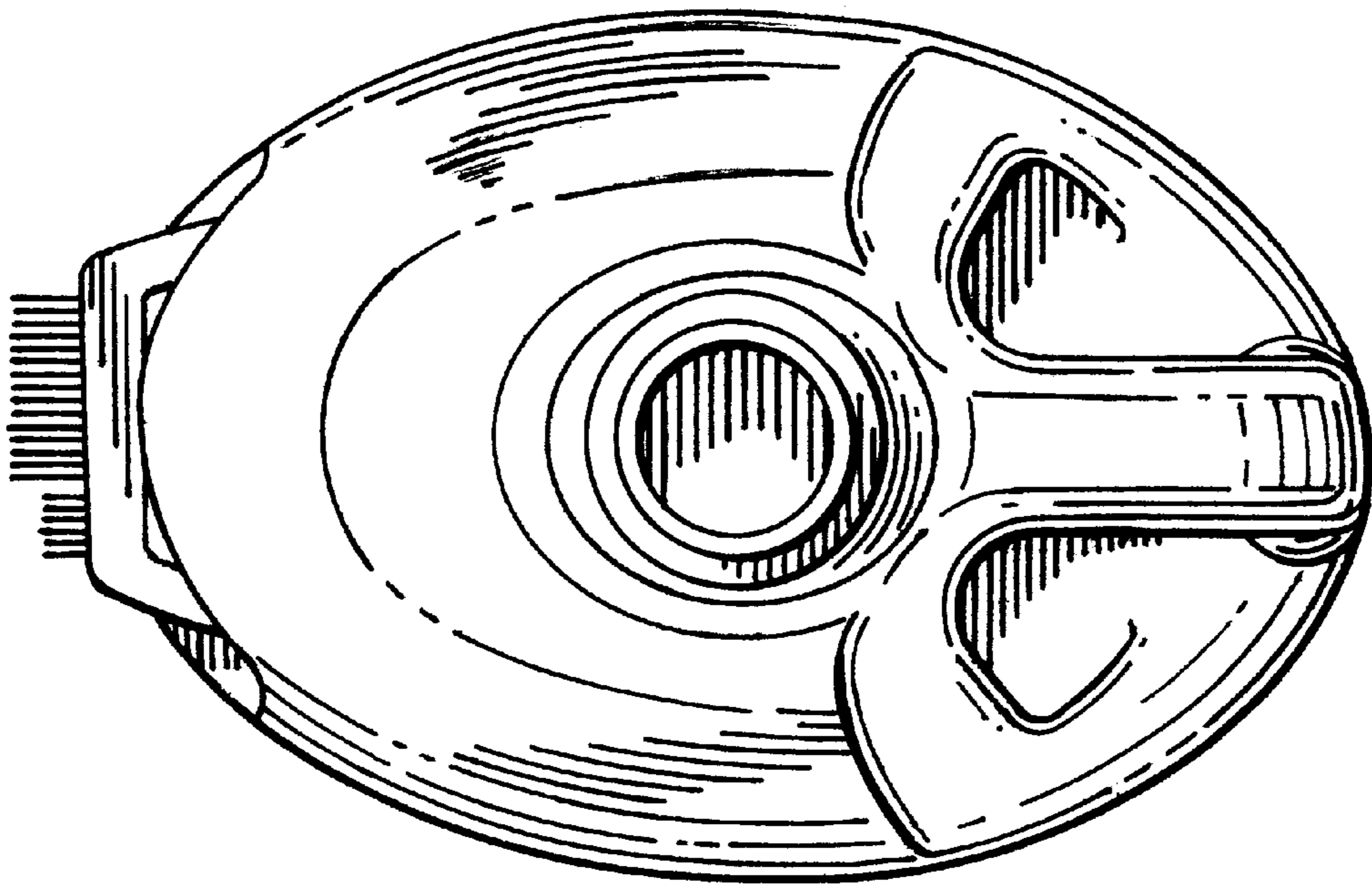

FIG. 3



*FIG. 4*



*FIG. 5*

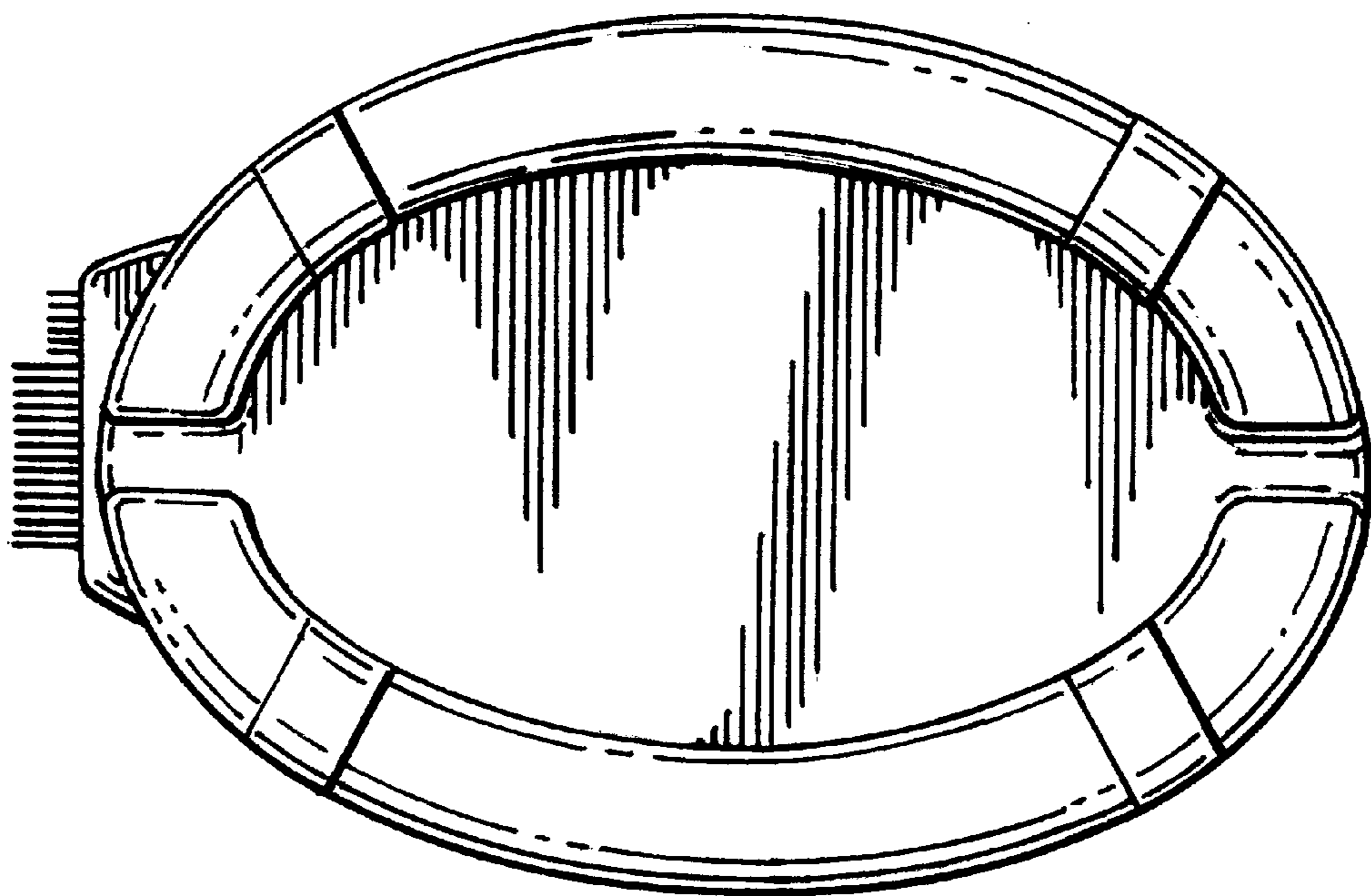

*FIG. 6*