



US00D453126S

(12) **United States Design Patent**
Nakazawa et al.

(10) **Patent No.:** **US D453,126 S**

(45) **Date of Patent:** **** *Jan. 29, 2002**

(54) **MOTORCYCLE**

(75) Inventors: **Tetsuya Nakazawa**, Rancho Palos Verdes; **Anthony Schroeder**, Huntington Beach; **Bruno Conte**, Redondo Beach, all of CA (US)

(73) Assignee: **Honda Giken Kogyo Kabushiki Kaisha**, Tokyo (JP)

(*) Notice: This patent is subject to a terminal disclaimer.

(**) Term: **14 Years**

(21) Appl. No.: **29/136,634**

(22) Filed: **Feb. 6, 2001**

(51) **LOC (7) Cl.** **12-03**

(52) **U.S. Cl.** **D12/110**

(58) **Field of Search** D12/107, 110;
180/219

(56) **References Cited**

U.S. PATENT DOCUMENTS

D339,089 S * 9/1993 Gibbons et al. D12/110
D417,173 S * 11/1999 Yamaguchi et al. D12/110

OTHER PUBLICATIONS

Cycle World, Oct. 1997, custom motorcycle by Mike Maldonado, pp. 56-59.*

* cited by examiner

Primary Examiner—Alan P. Douglas

Assistant Examiner—Linda Brooks

(74) *Attorney, Agent, or Firm*—Banner & Witcoff, Ltd.

(57) **CLAIM**

The ornamental design for a motorcycle, as shown and described.

DESCRIPTION

FIG. 1 is a frontal perspective view of a motorcycle showing our new design;

FIG. 2 is a rear perspective view thereof;

FIG. 3 is a side elevational view of one side thereof;

FIG. 4 is a side elevational view of the other side thereof;

FIG. 5 is a front elevational view thereof;

FIG. 6 is a rear elevational view thereof; and,

FIG. 7 is a top plan view thereof.

The broken line showing of the wheels, tires, rear view mirror, pedals, gauges and tank cap element is for illustrative purposes only and forms no part of the claimed design. The unillustrated bottom view forms no part of the claimed design.

1 Claim, 5 Drawing Sheets

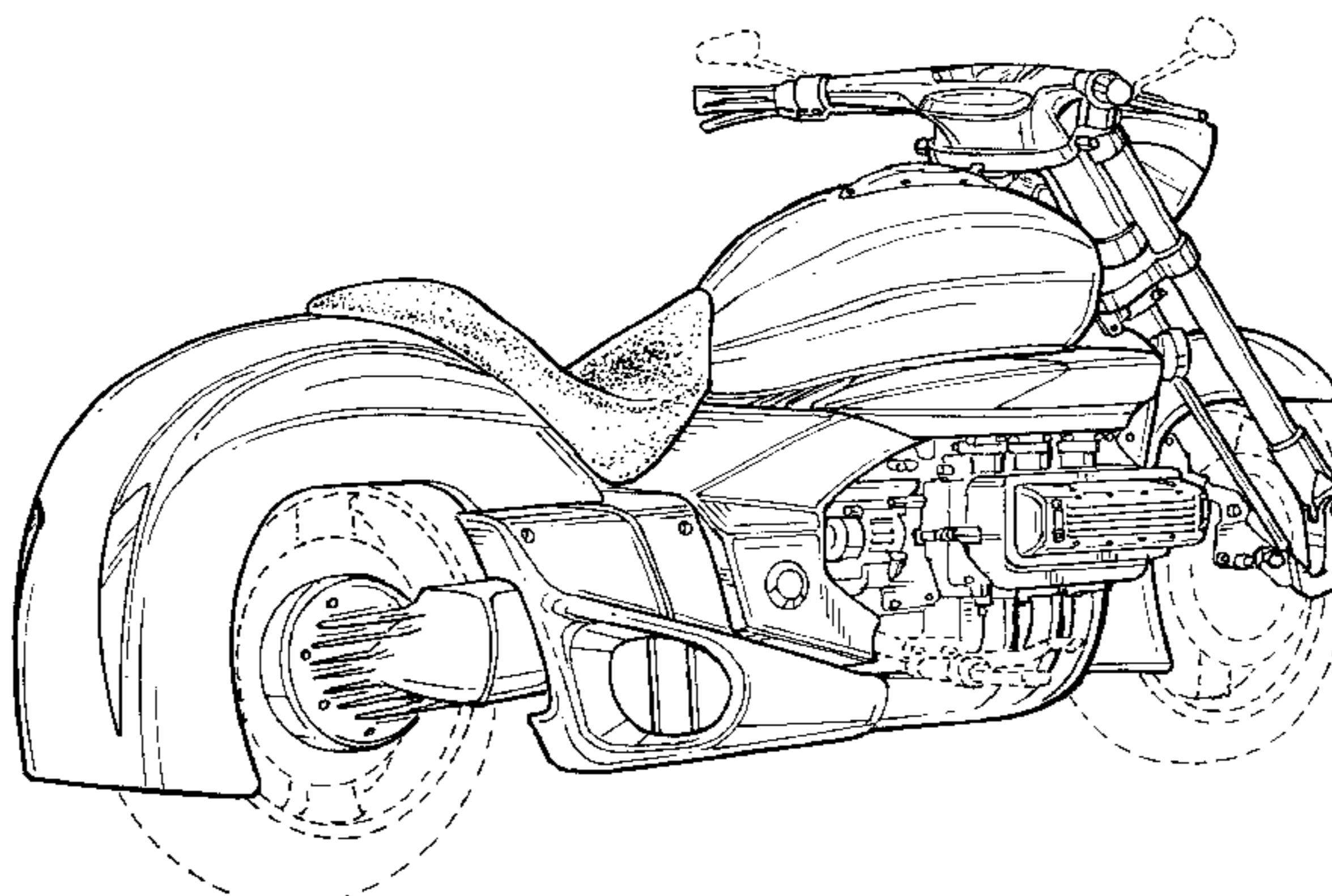
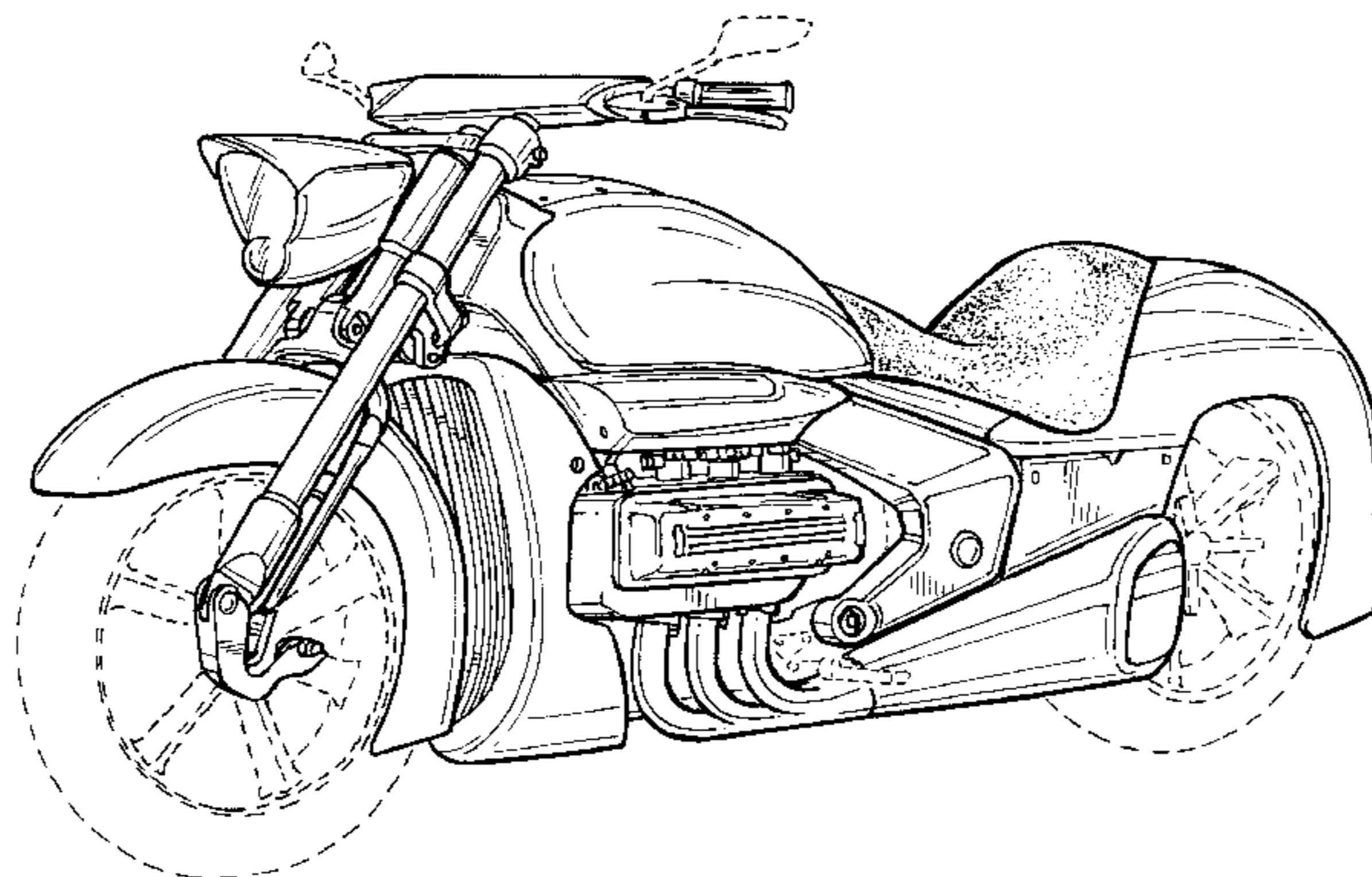

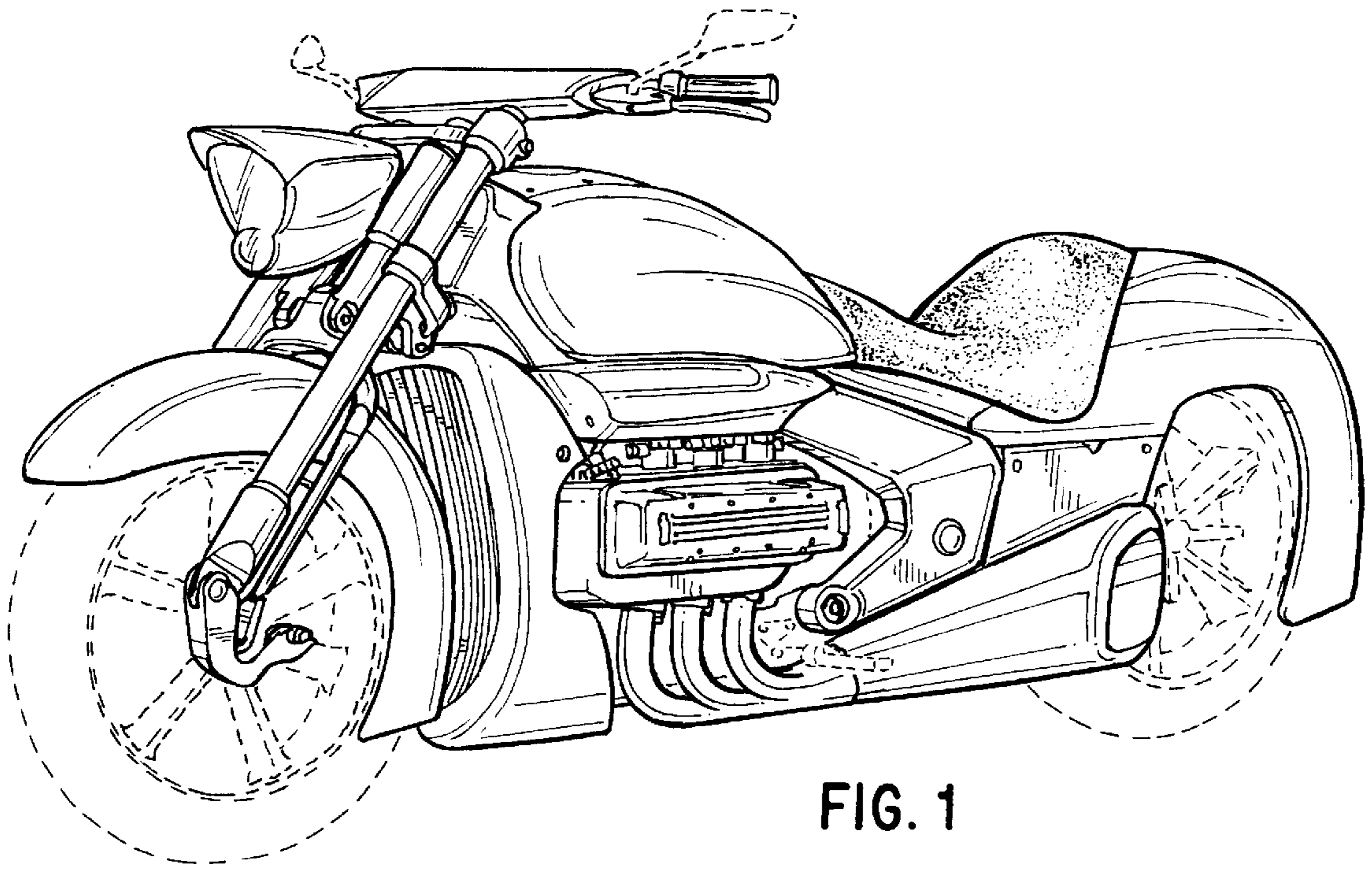

FIG. 1

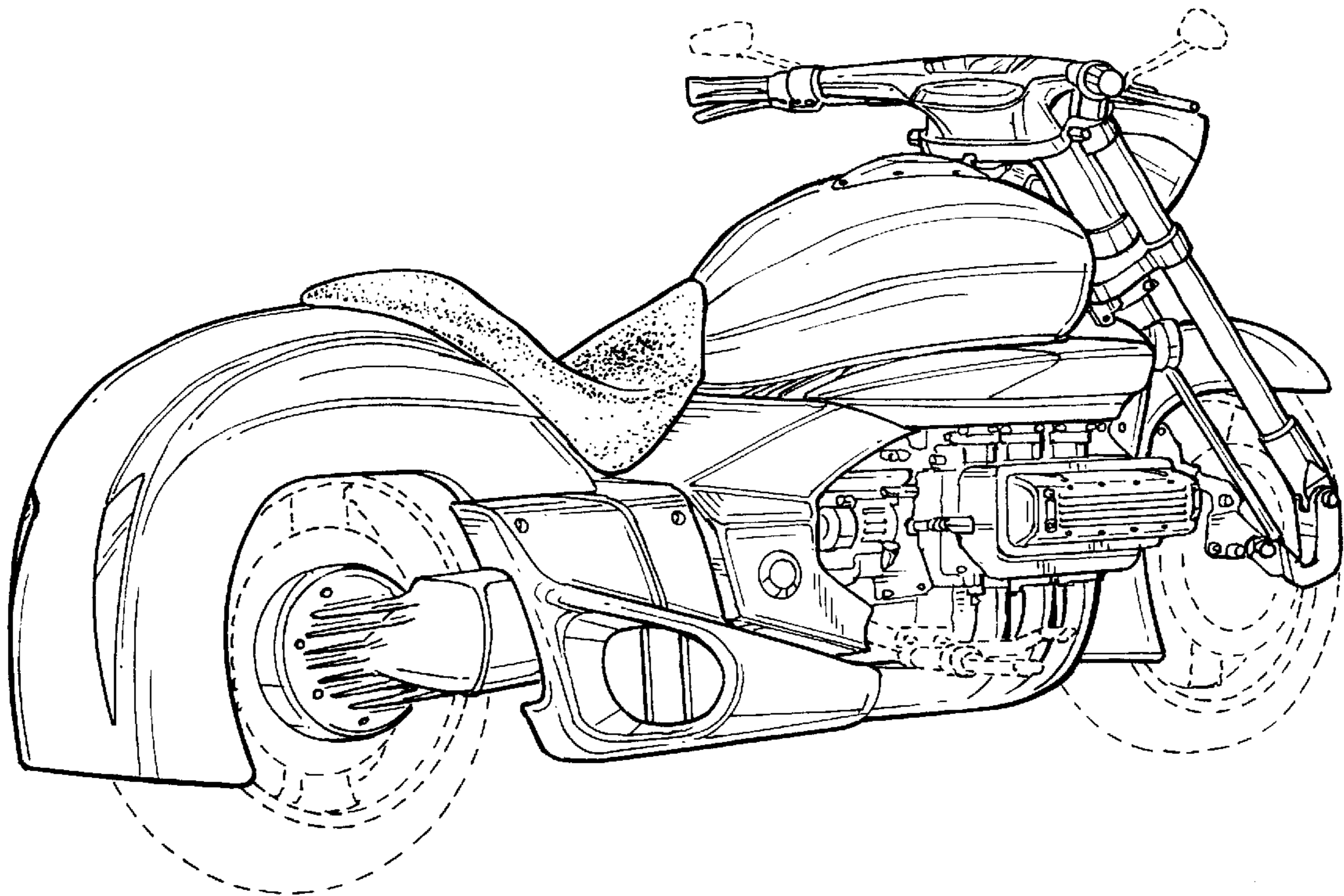

FIG. 2

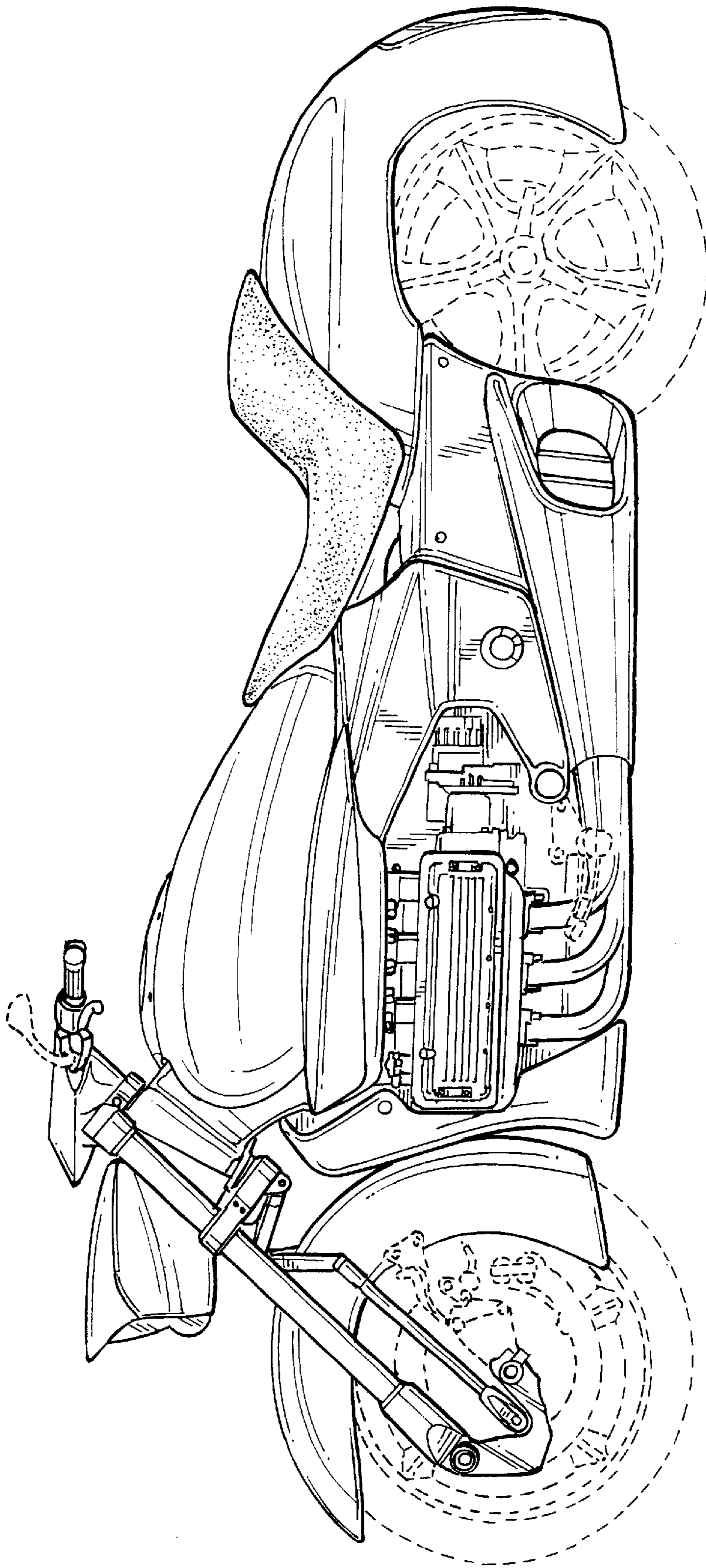

FIG. 3

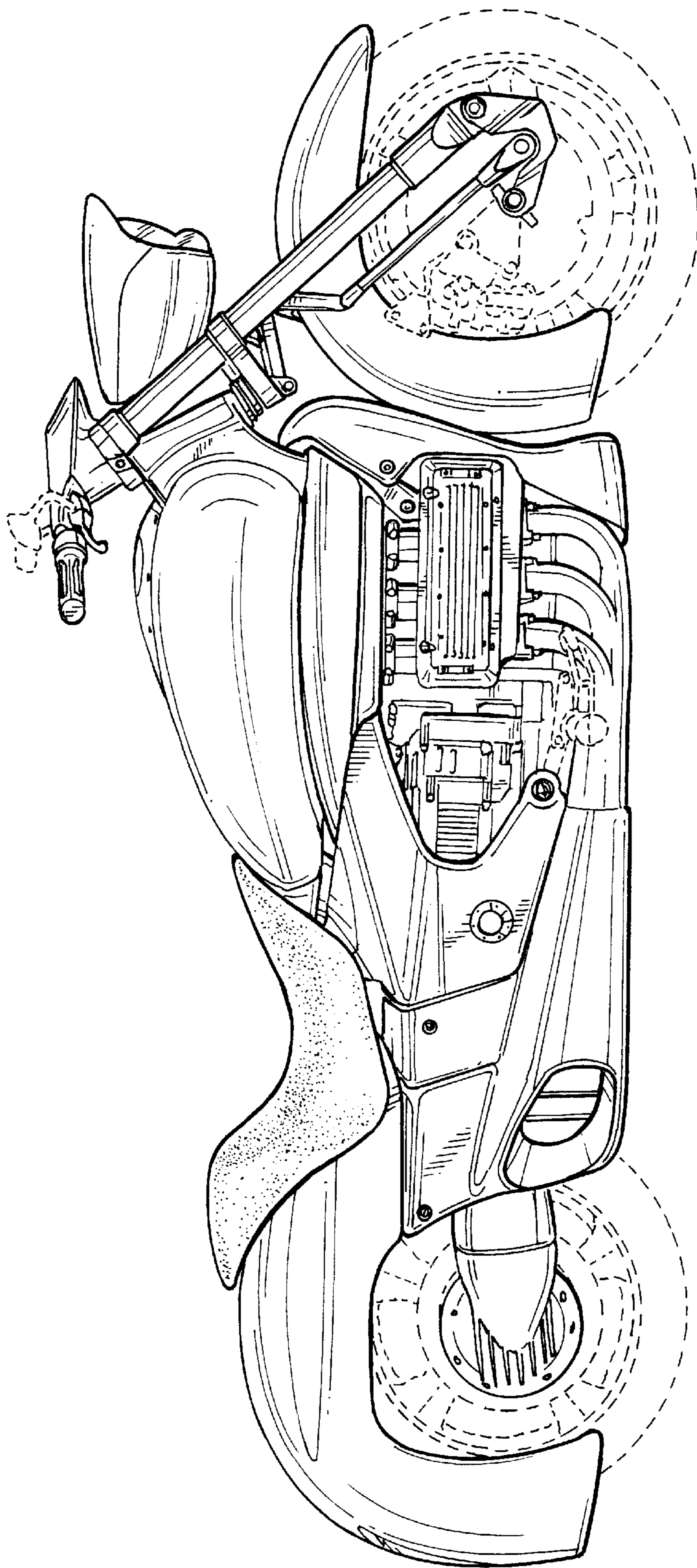

FIG. 4

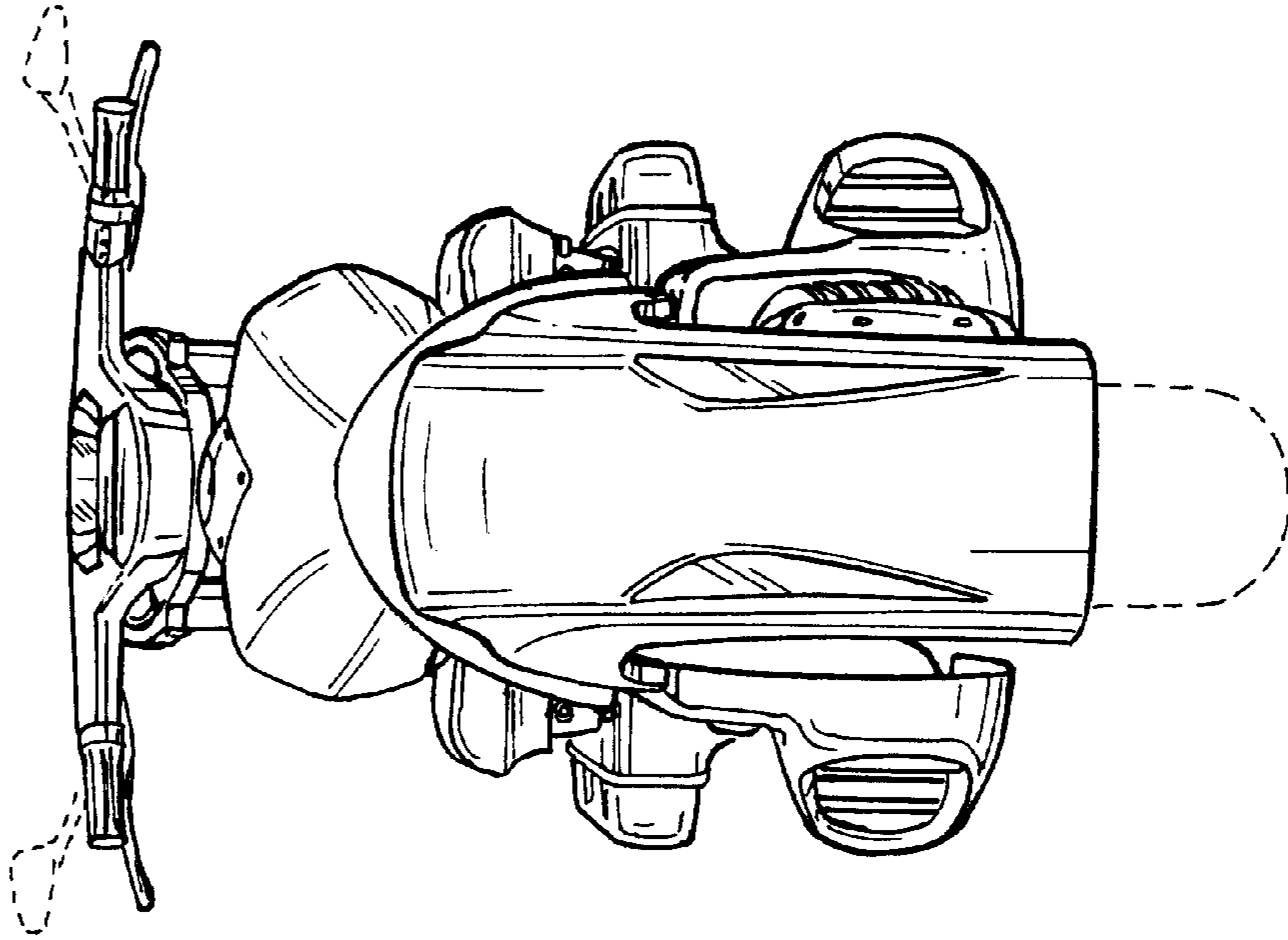

FIG. 6

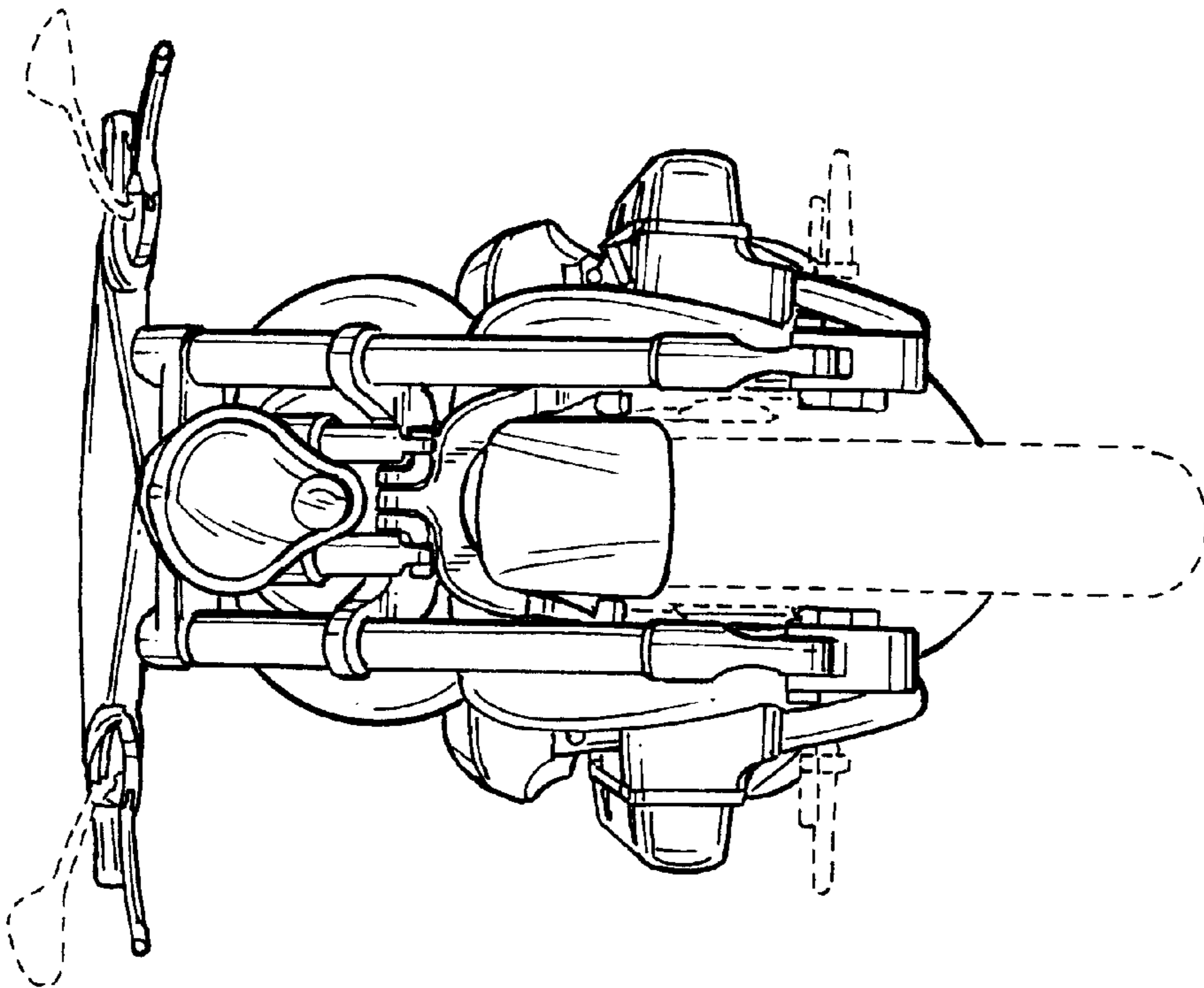

FIG. 5

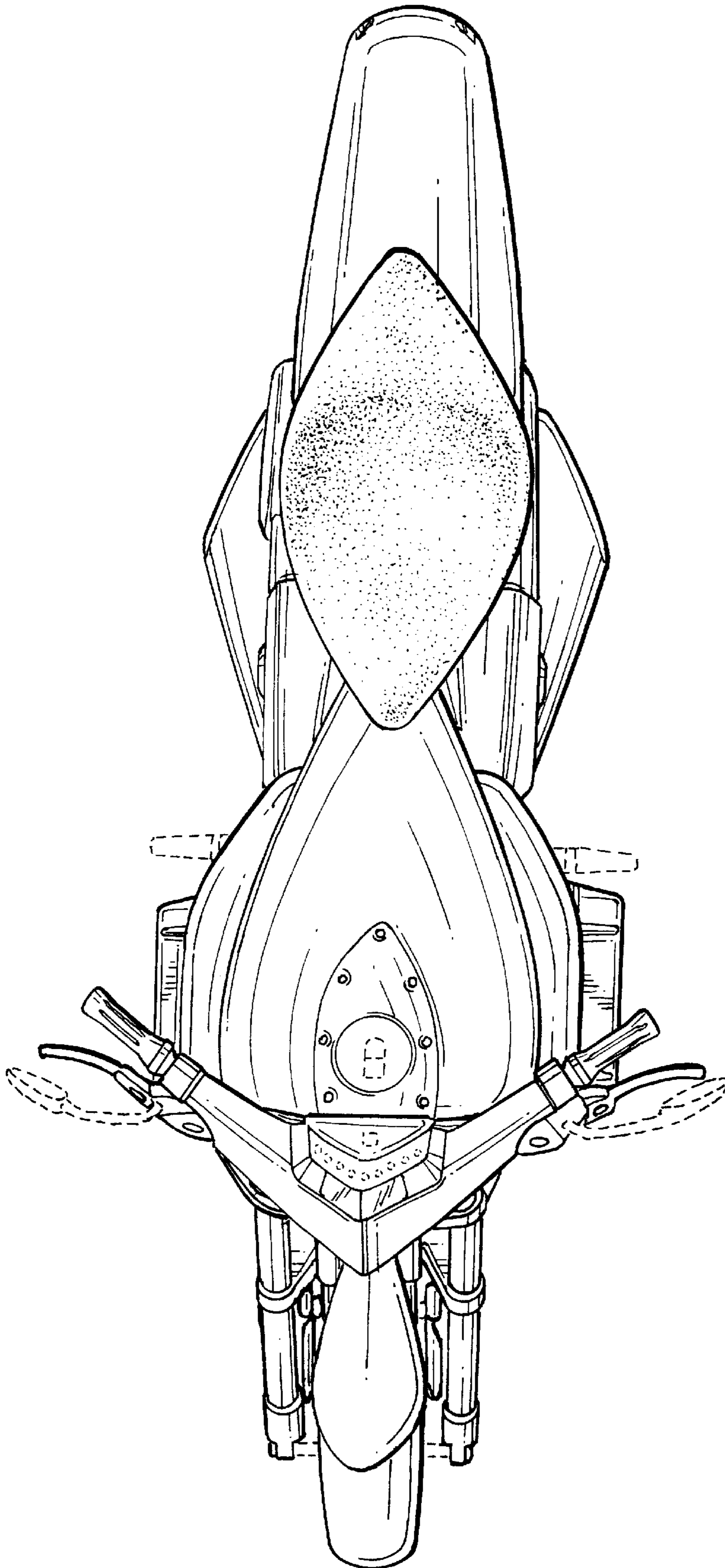

FIG. 7