



US00D452484B1

(12) **United States Design Patent**
Milanczak

(10) **Patent No.:** **US D452,484 S**

(45) **Date of Patent:** **** Dec. 25, 2001**

(54) **FUSE ASSEMBLY**

(75) **Inventor:** **Edwin Milanczak**, Victoria Harbour (CA)

(73) **Assignee:** **Canadian Shunt Industries Ltd.**, Markham (CA)

(**) **Term:** **14 Years**

(21) **Appl. No.:** **29/132,603**

(22) **Filed:** **Nov. 9, 2000**

(51) **LOC (7) Cl.** **13-03**

(52) **U.S. Cl.** **D13/161**

(58) **Field of Search** D13/160, 161;
200/237, 293, 297, 302.3

(56) **References Cited**

U.S. PATENT DOCUMENTS

D. 325,725	*	4/1992	Yamagata et al.	D13/160
D. 336,073		6/1993	Happ .		
D. 346,791		5/1994	Marach et al. .		
D. 348,048	*	6/1994	Marach et al.	D13/160
D. 355,642		2/1995	Marach et al. .		
D. 355,893		2/1995	Marach et al. .		
D. 367,041	*	2/1996	Alfaro et al.	D13/160
D. 406,106	*	2/1999	Gonser	D13/160
5,355,274		10/1994	Marach et al. .		

* cited by examiner

Primary Examiner—Brian N. Vinson

(74) *Attorney, Agent, or Firm*—Merchant & Gould P.C.

(57) **CLAIM**

The ornamental design for a fuse assembly, as shown and described.

DESCRIPTION

FIG. 1 is a top, front, and left side perspective view of a fuse assembly showing a first embodiment of my new design;

FIG. 2 is a right side elevational view thereof;

FIG. 3 is a top plan view thereof;

FIG. 4 is a left side elevational view thereof;

FIG. 5 is a rear elevational view thereof;

FIG. 6 is a front elevational view thereof;

FIG. 7 is a top, front, and left side perspective view of the front portion of the fuse assembly of FIG. 1, with the fuse holder portion omitted;

FIG. 8 is a right side elevational view thereof;

FIG. 9 is a top plan view thereof;

FIG. 10 is a left side elevational view thereof;

FIG. 11 is a rear elevational view thereof;

FIG. 12 is a front elevational view thereof;

FIG. 13 is a top, front, and left side perspective view of the fuse holder portion of the fuse assembly of FIG. 1, with the front portion omitted;

FIG. 14 is a right side elevational view thereof;

FIG. 15 is a top plan view thereof;

FIG. 16 is a rear elevational view thereof;

FIG. 17 is a front elevational view thereof;

FIG. 18 is a bottom plan view thereof;

FIG. 19 is a left side elevational view thereof; and,

FIG. 20 is a top, front, and left side perspective view of a fuse assembly showing a second embodiment of my new design, the only difference residing in the configuration of protruding flat element on the front face.

1 Claim, 14 Drawing Sheets

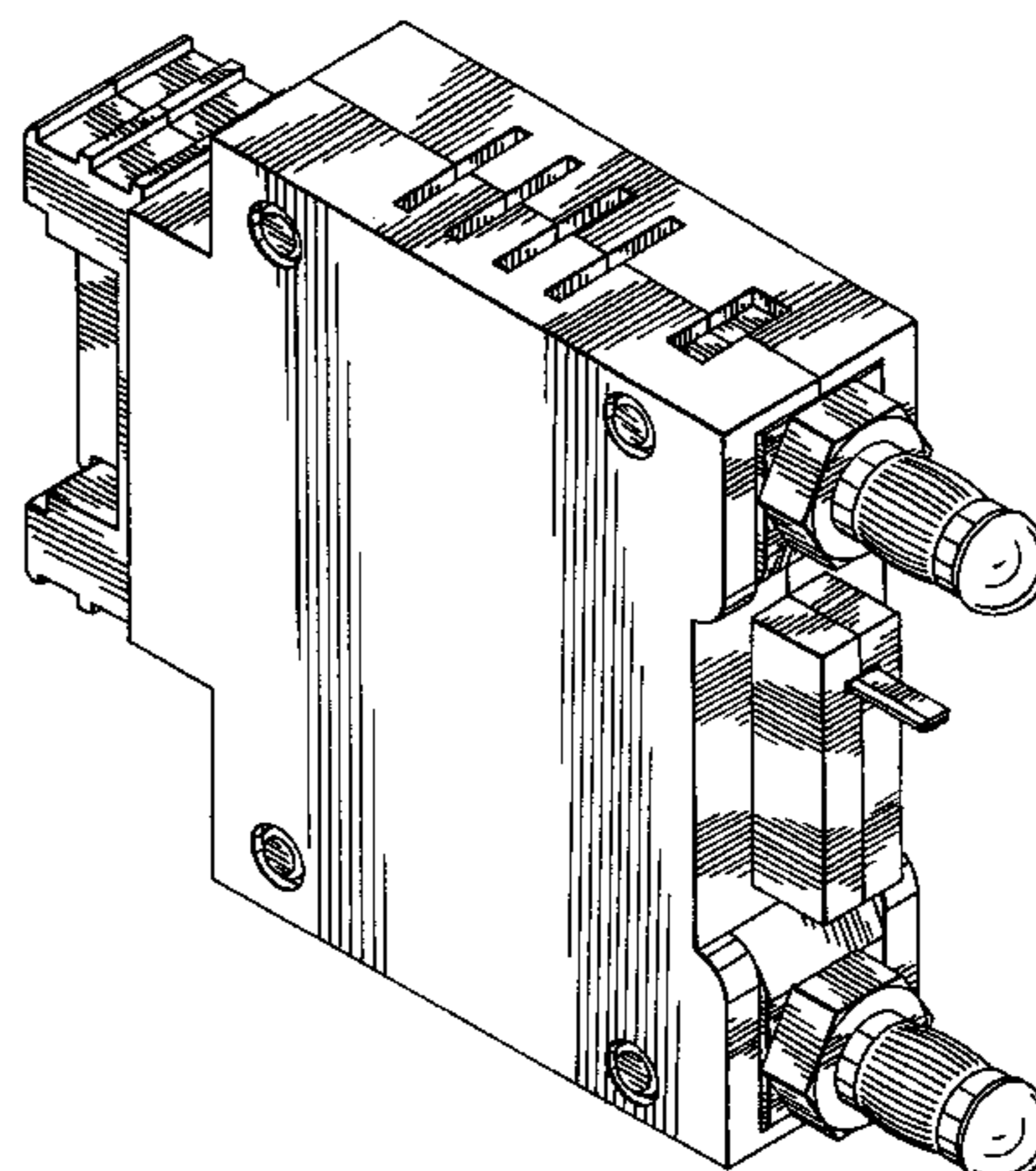
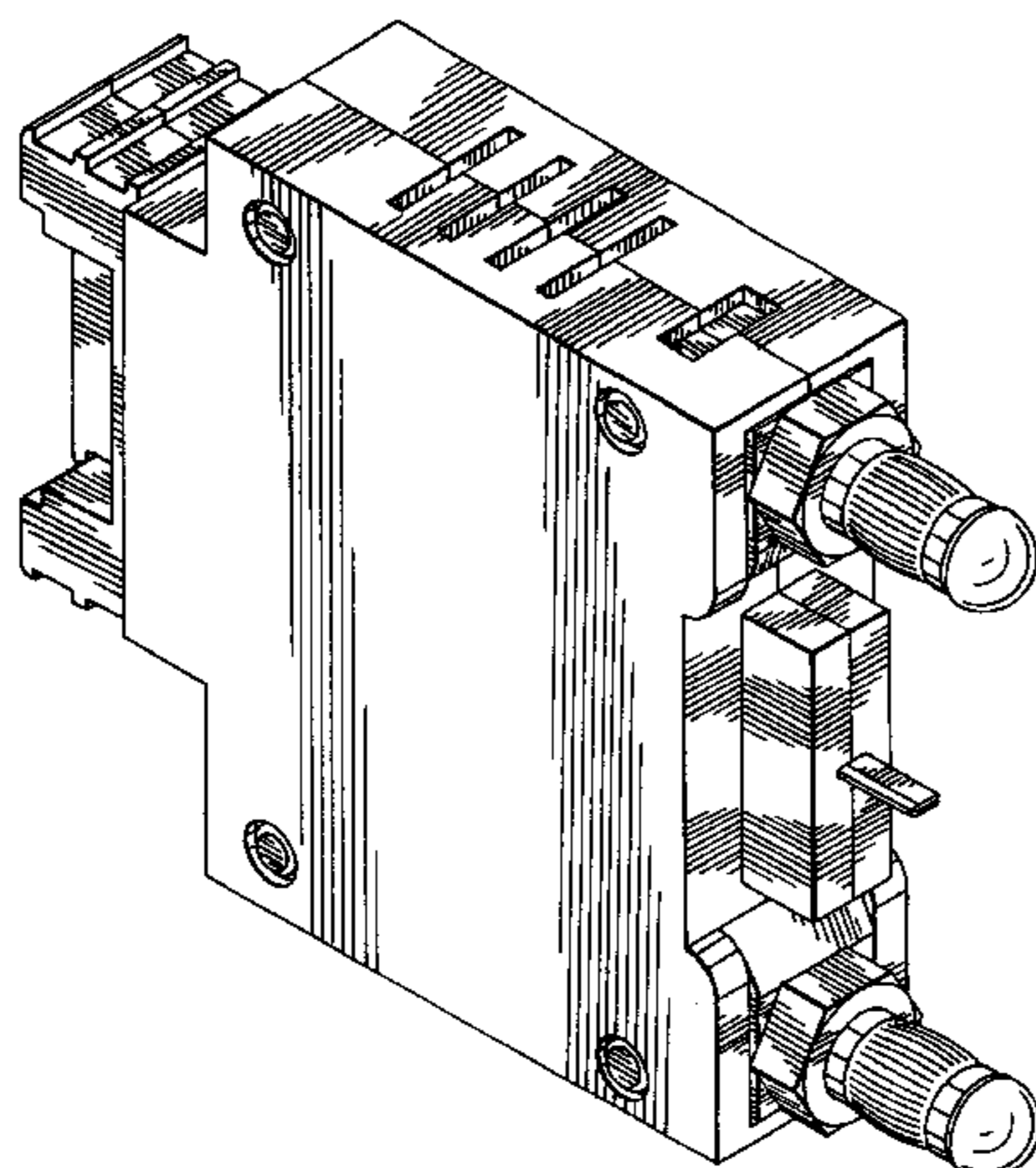

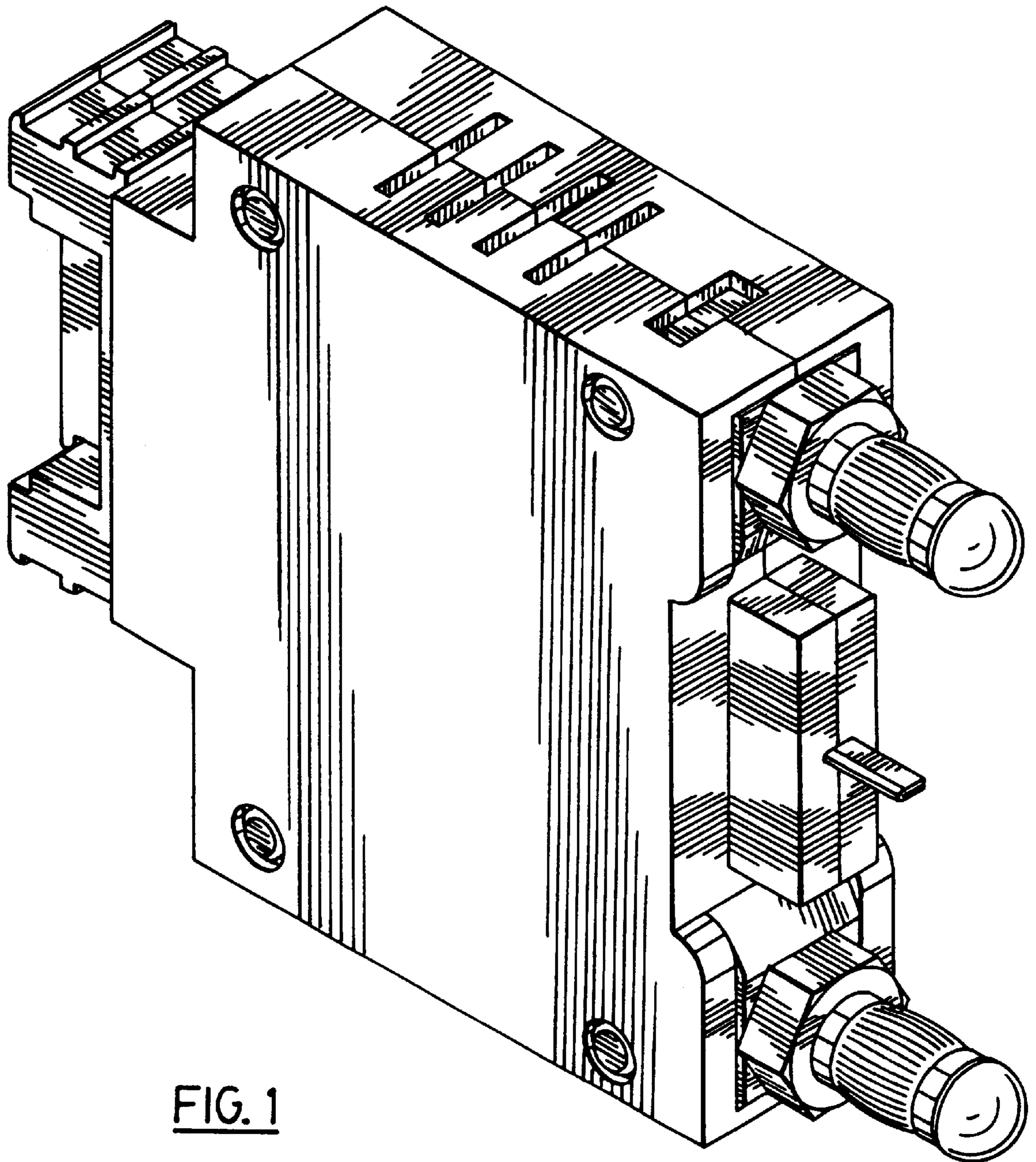
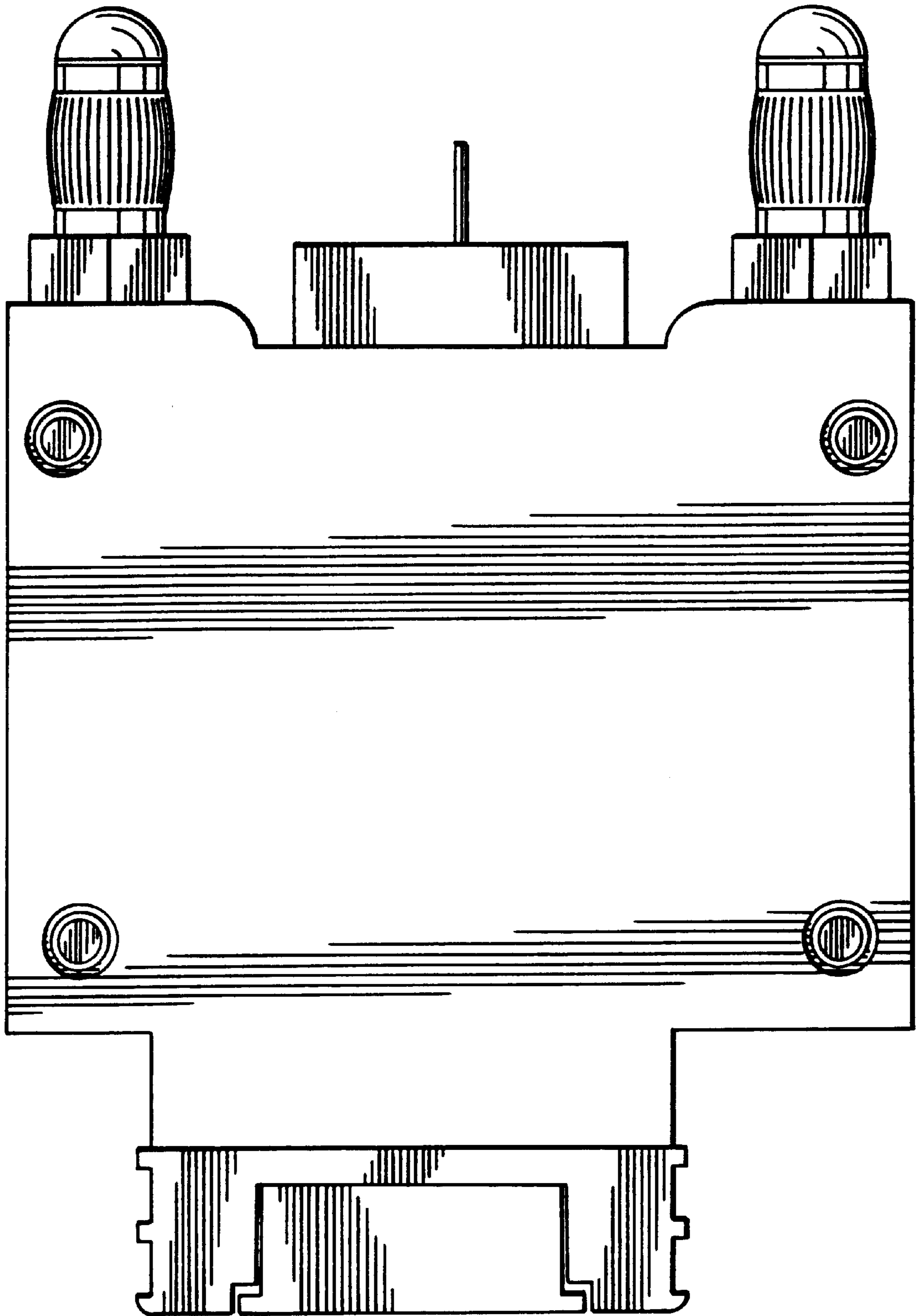

FIG. 1

FIG. 2



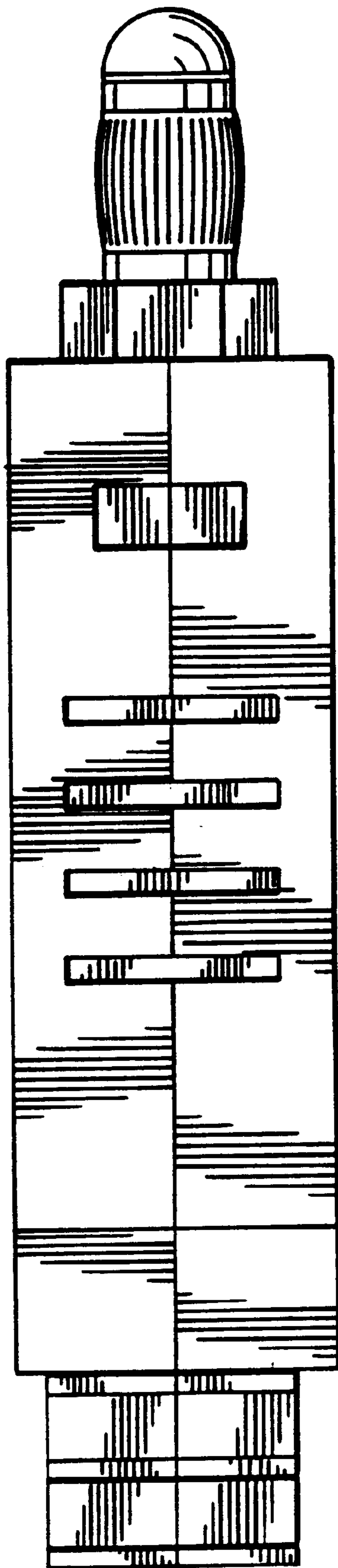

FIG. 3

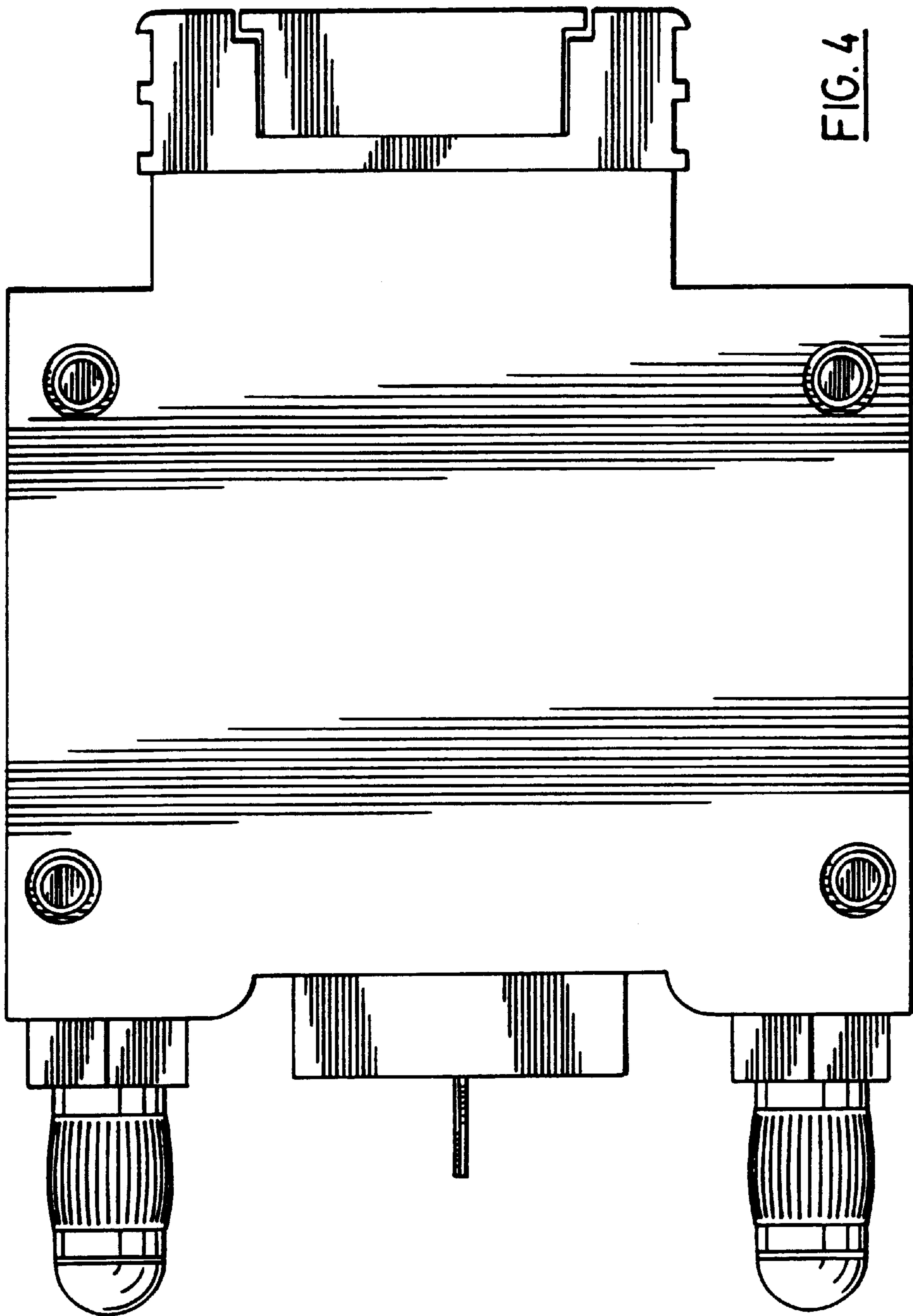

FIG. 6

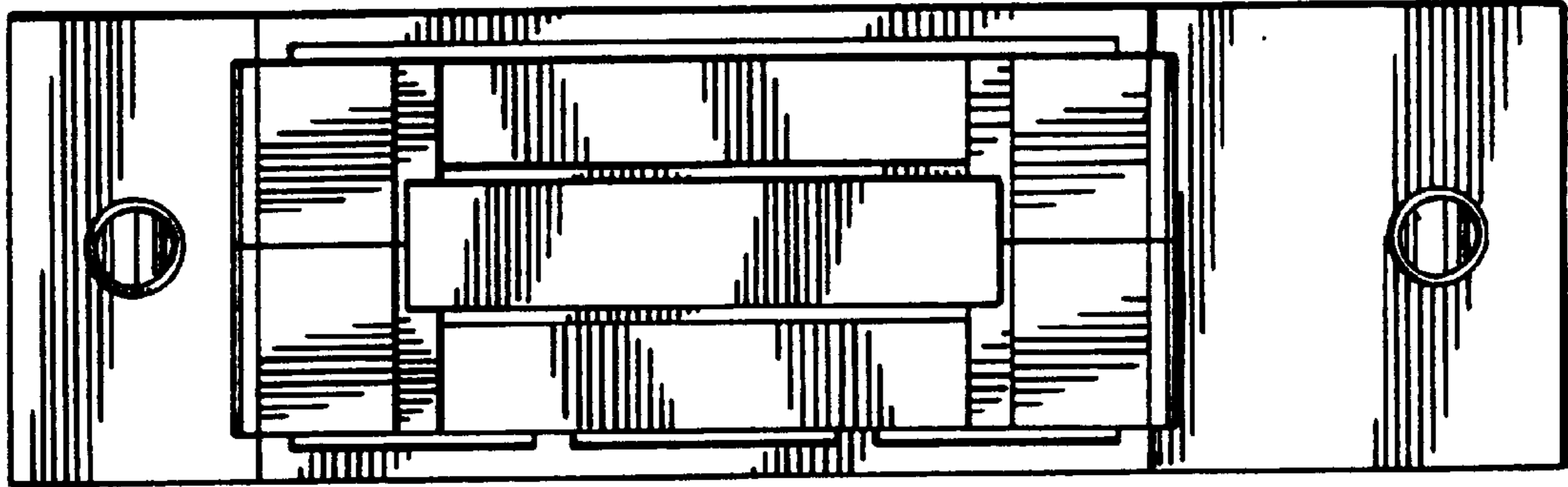
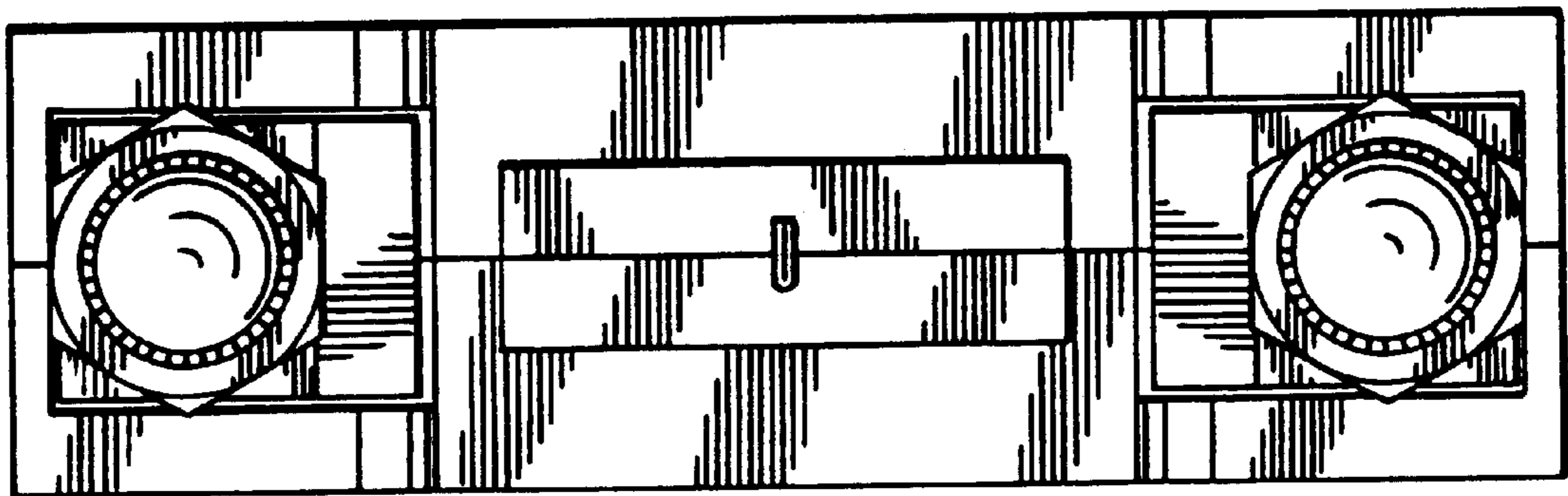

FIG. 5



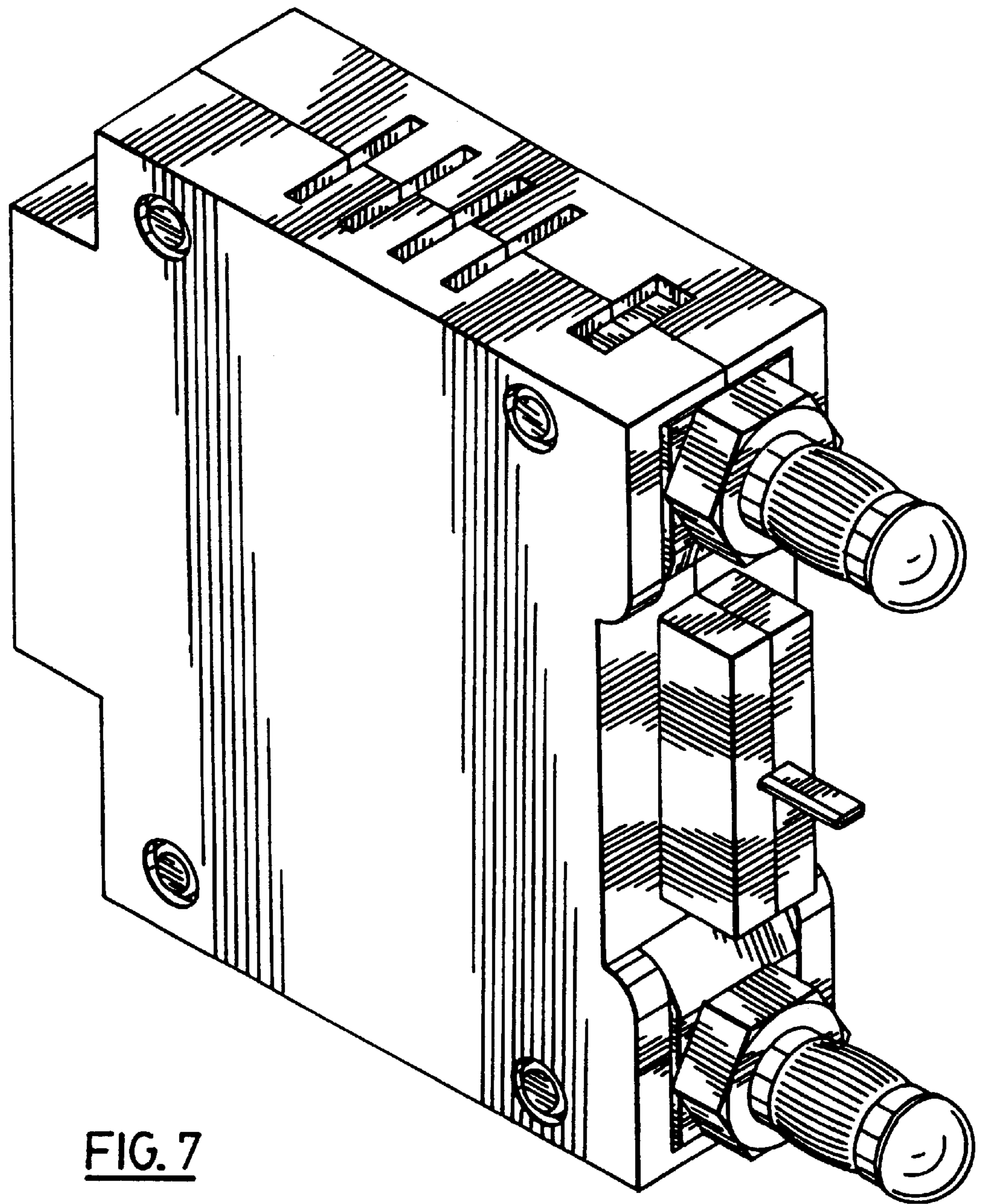
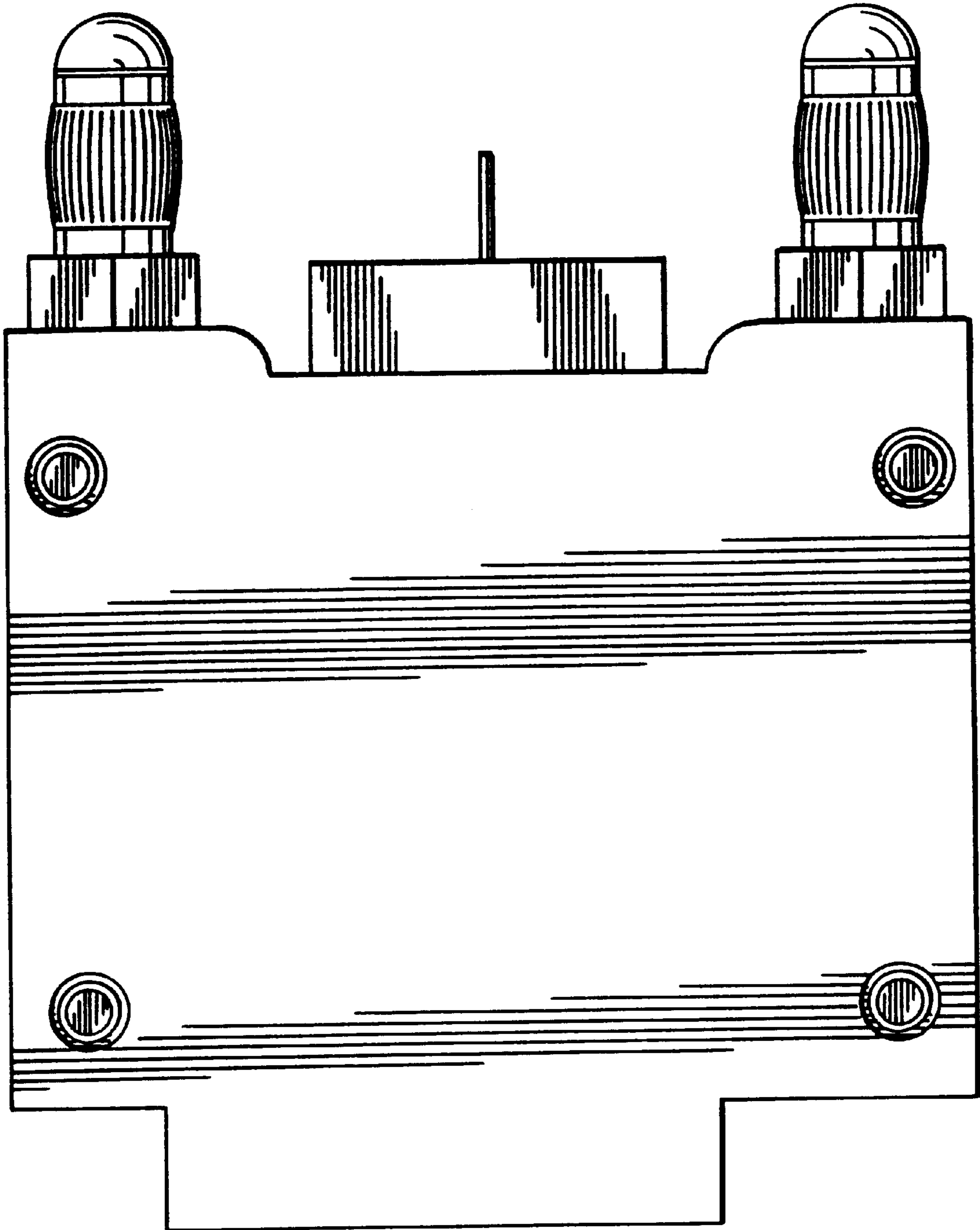

FIG. 7

FIG. 8



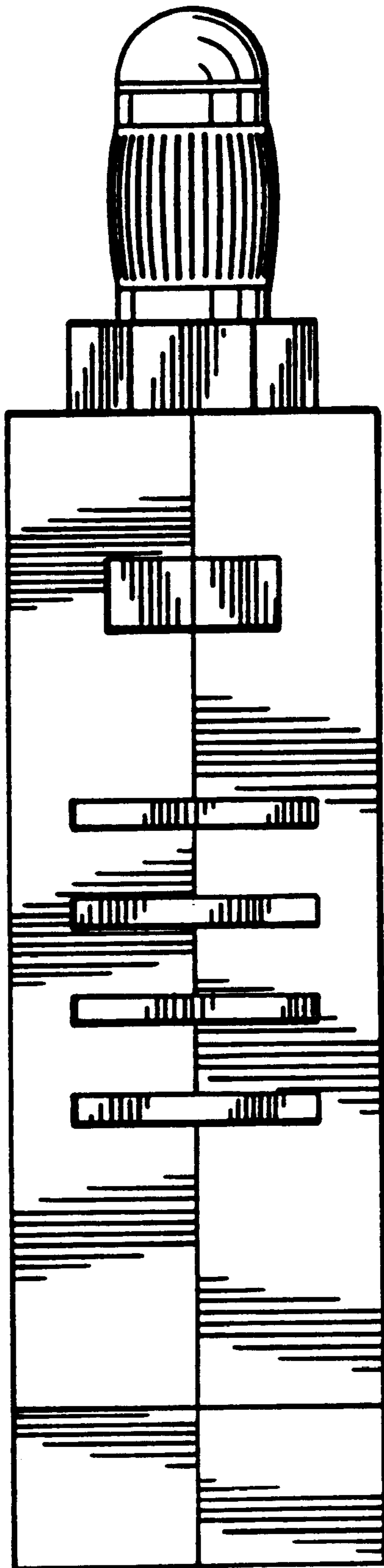

FIG. 9

FIG. 10

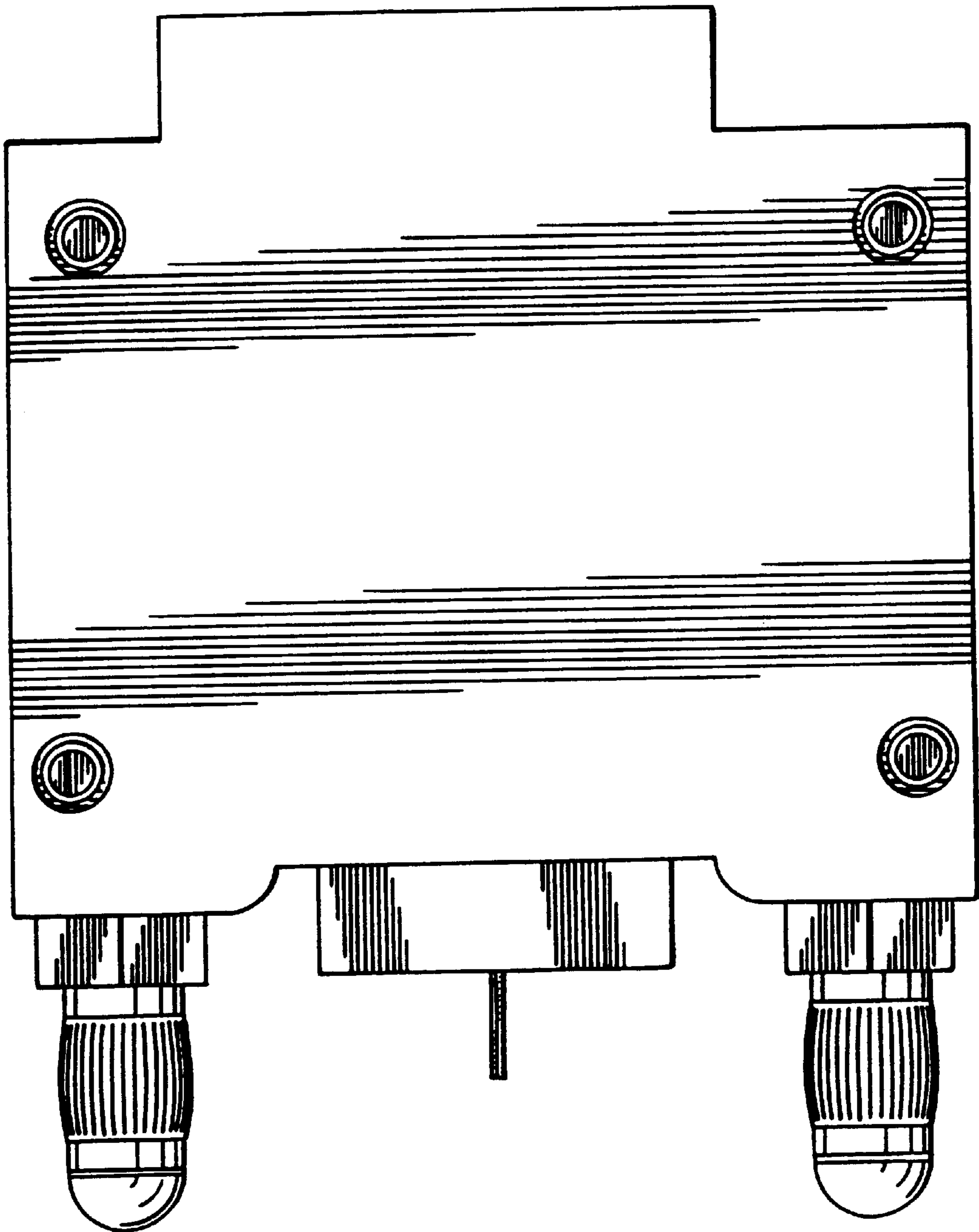

FIG. 12

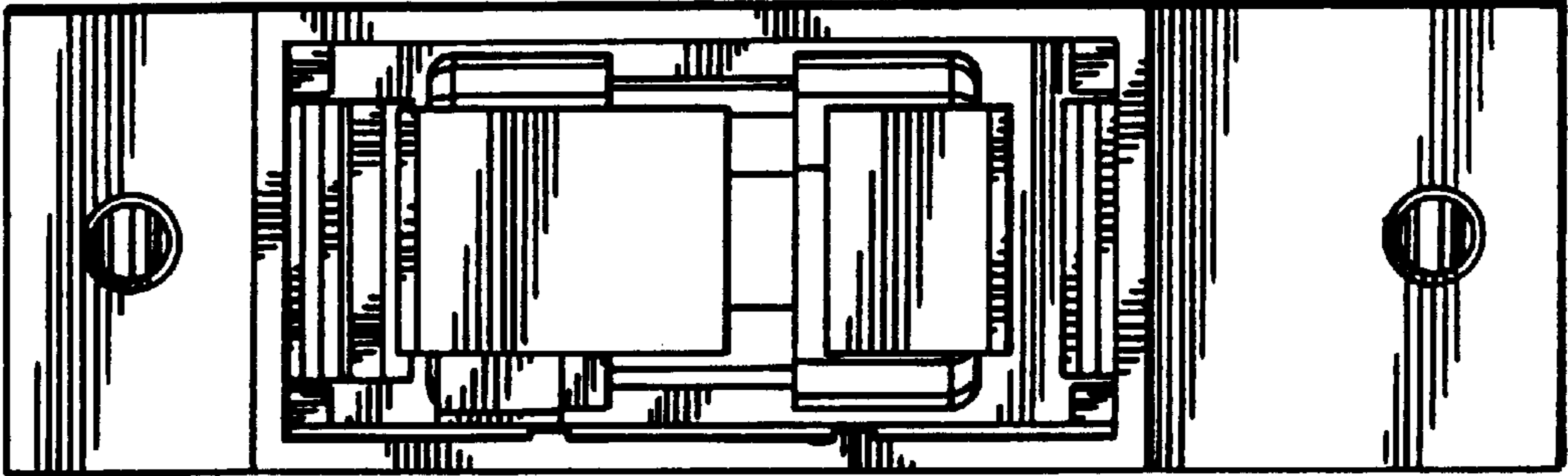
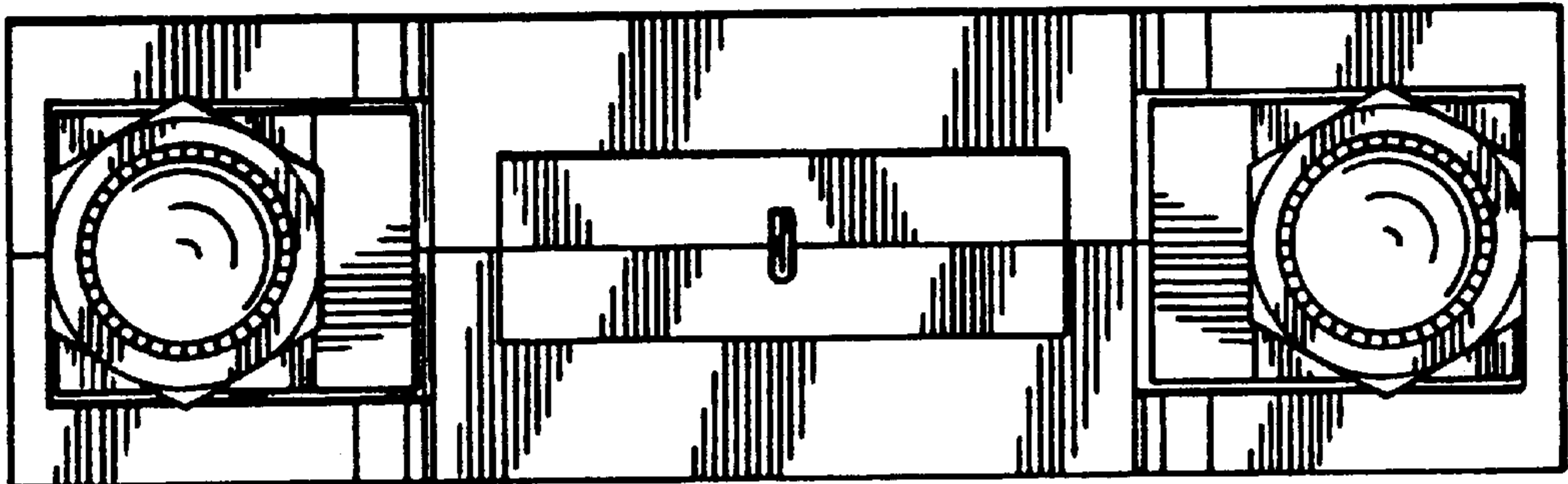

FIG. 11



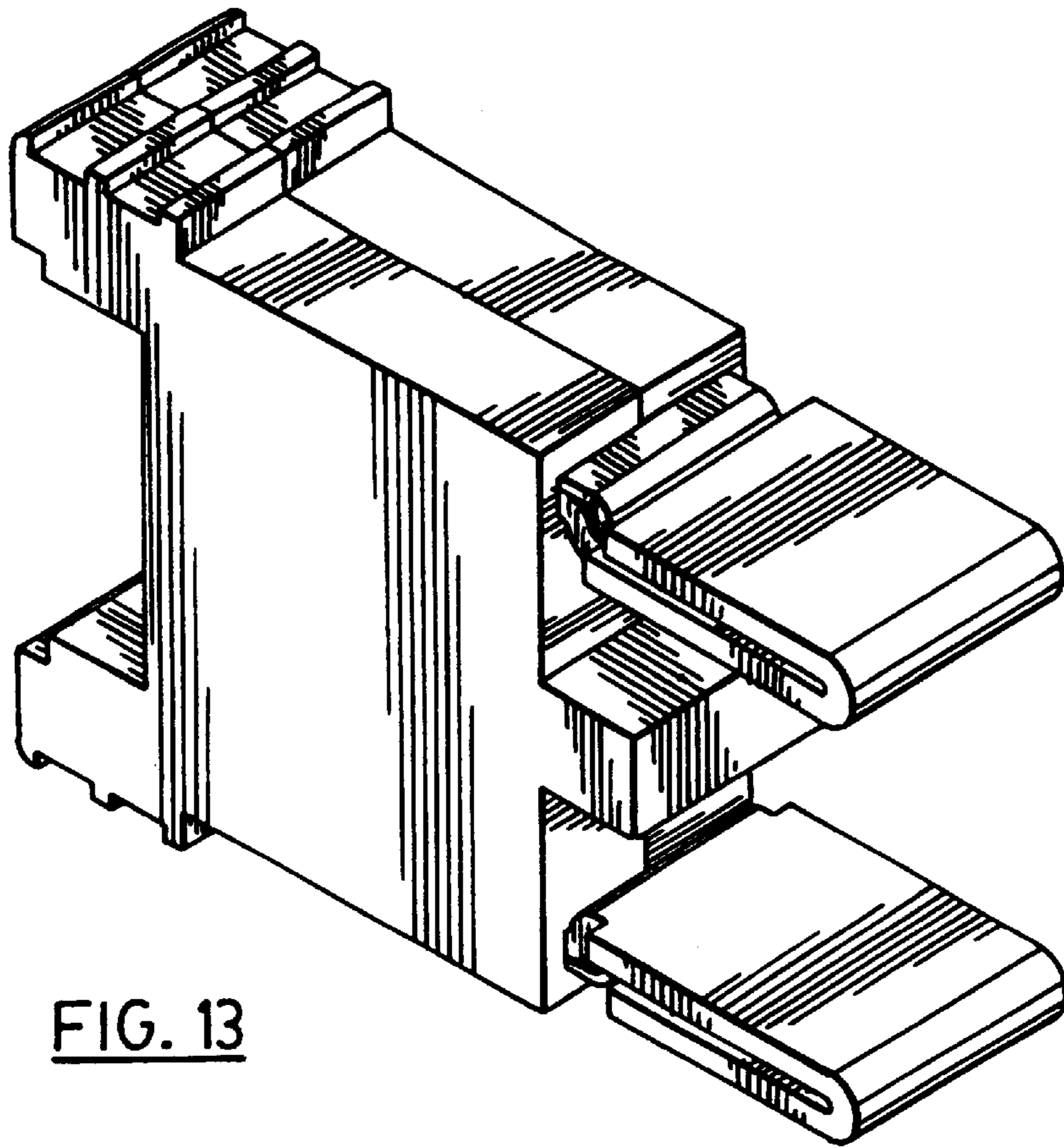

FIG. 13

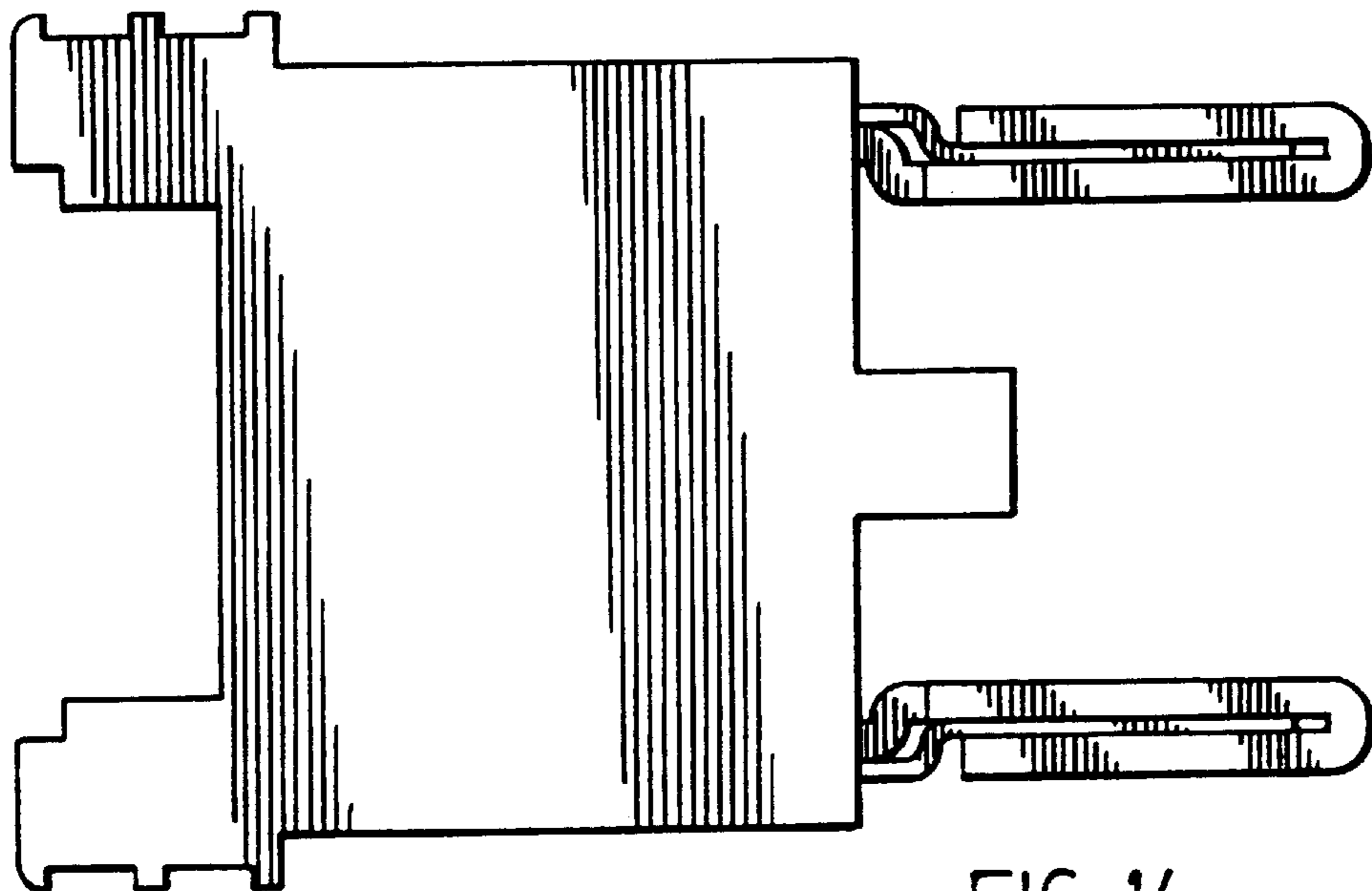

FIG. 14

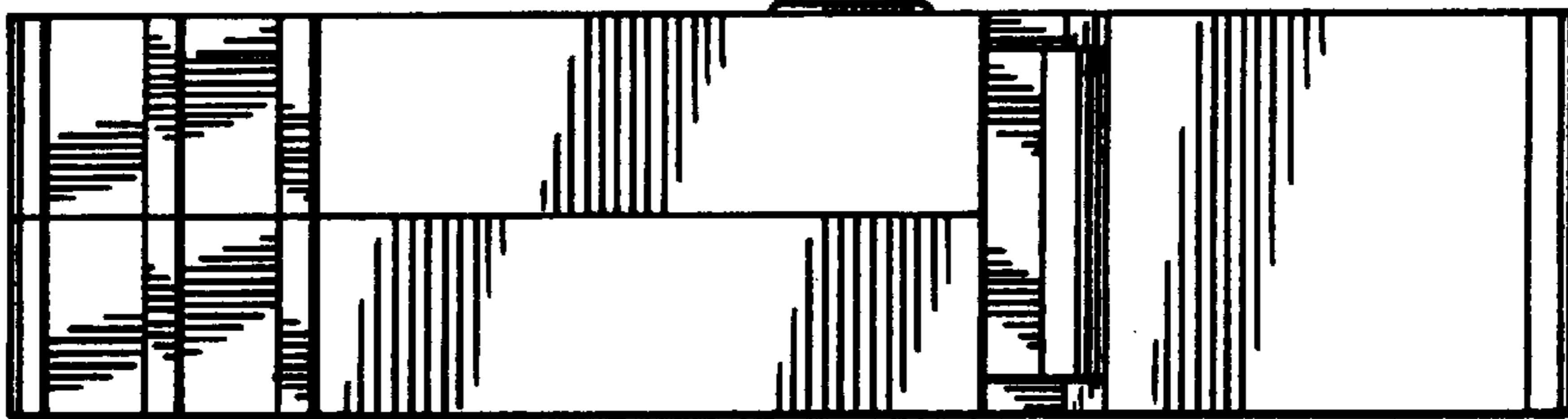

FIG. 15

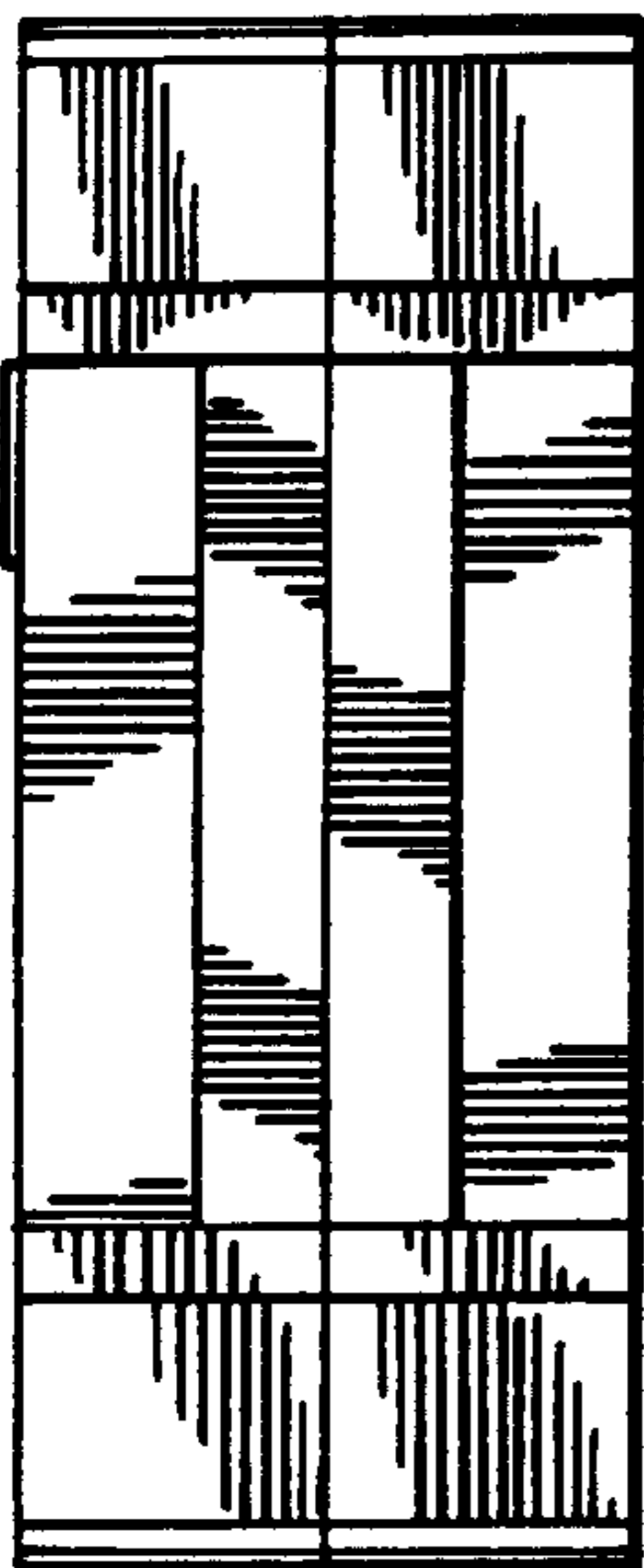

FIG. 16

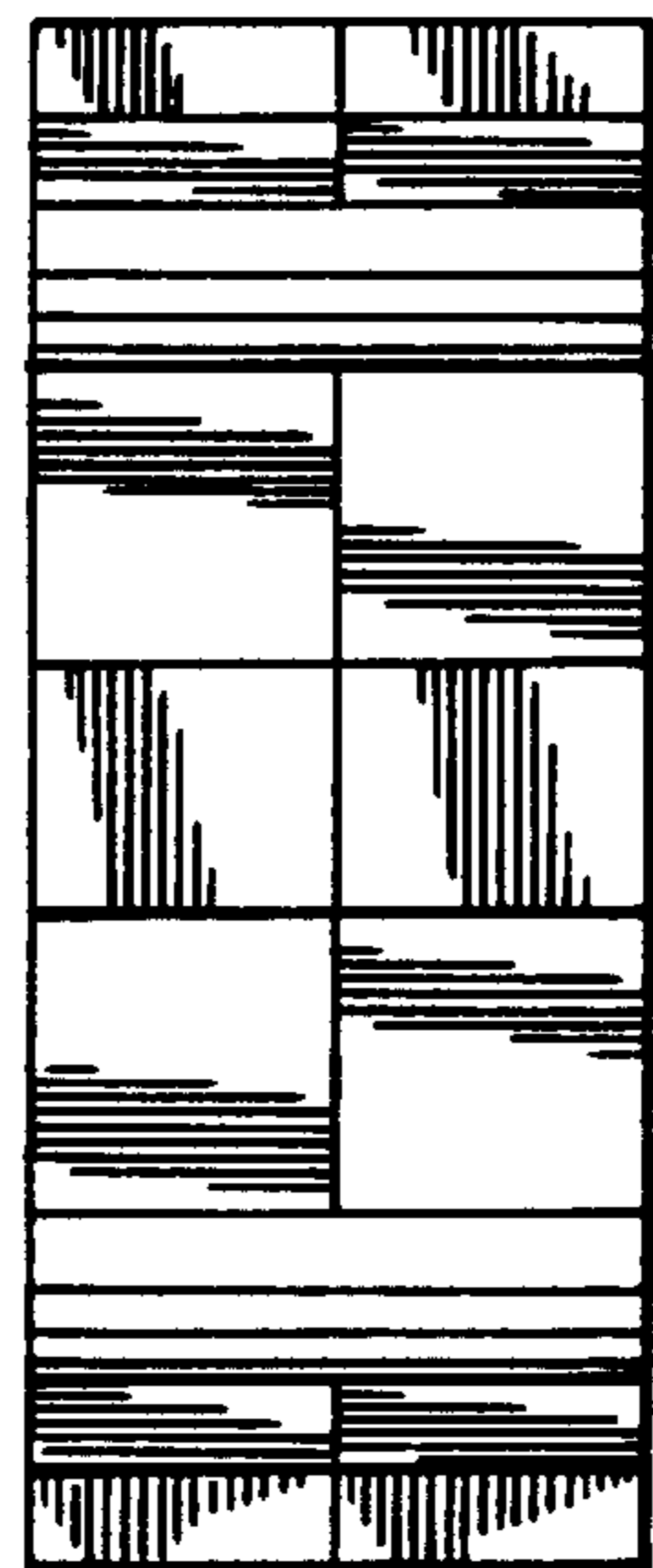

FIG. 17

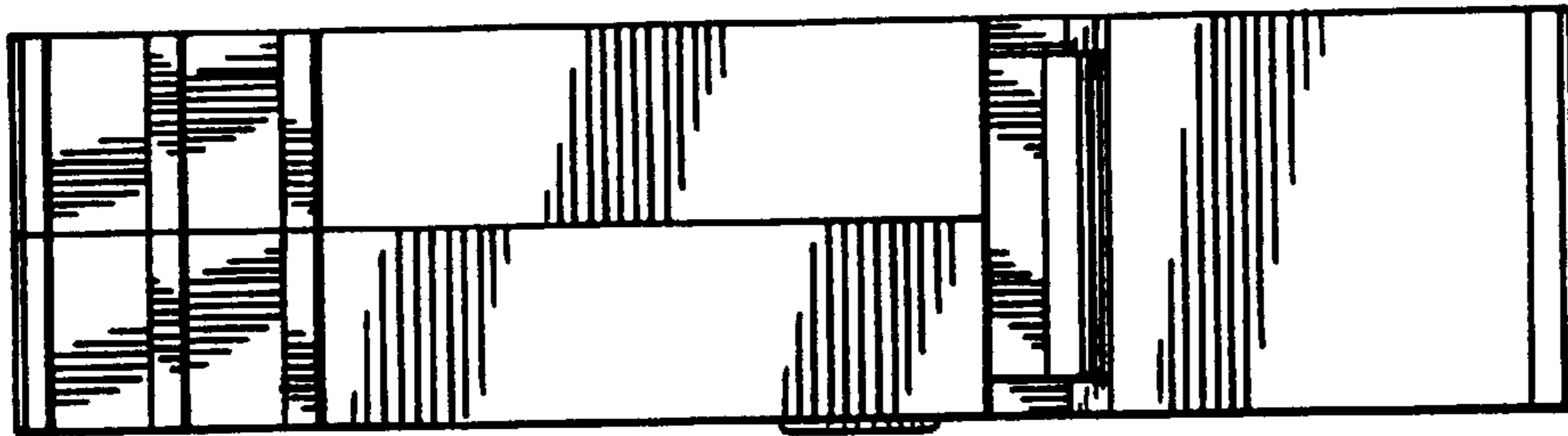

FIG. 18

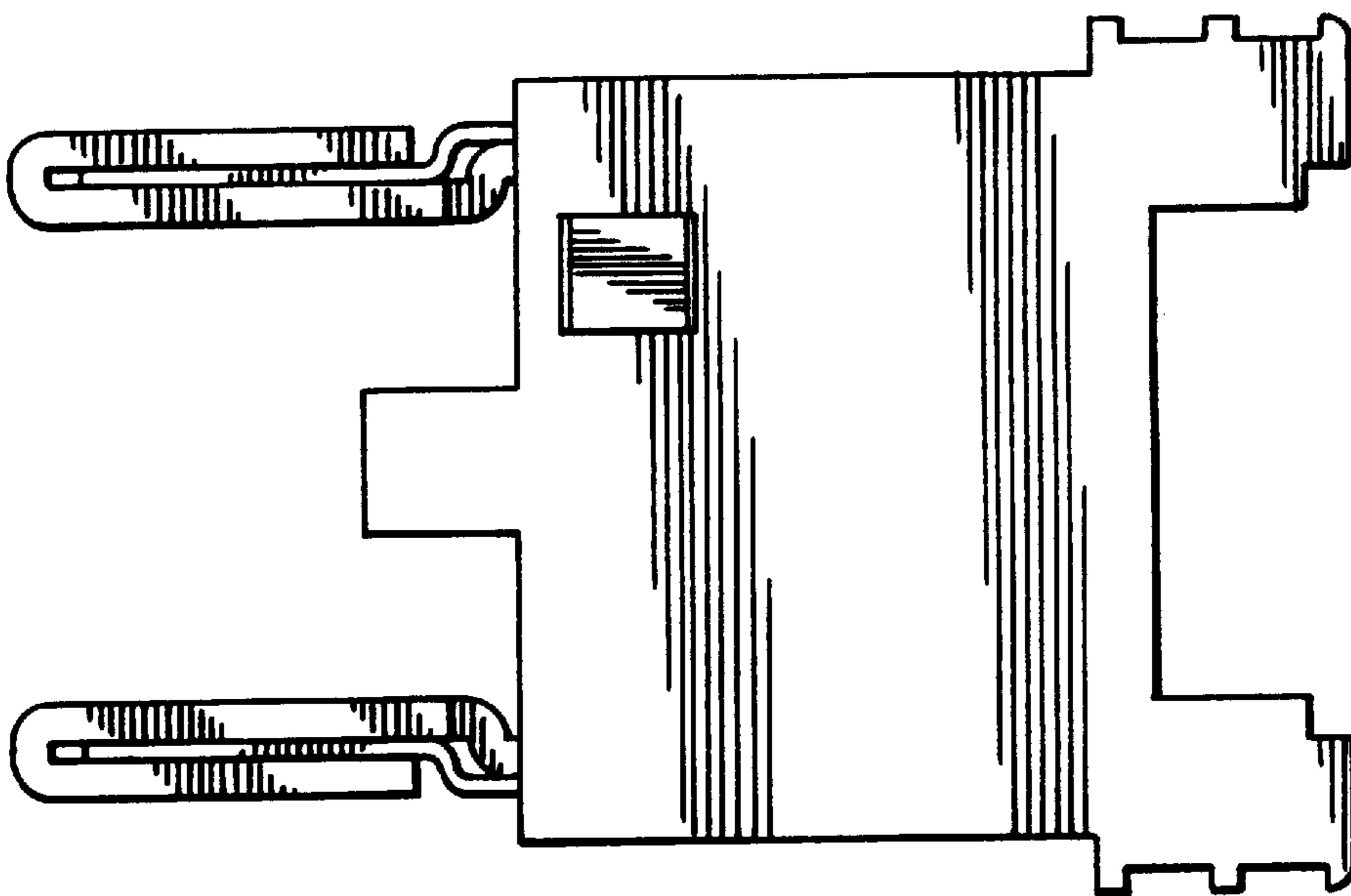

FIG. 19

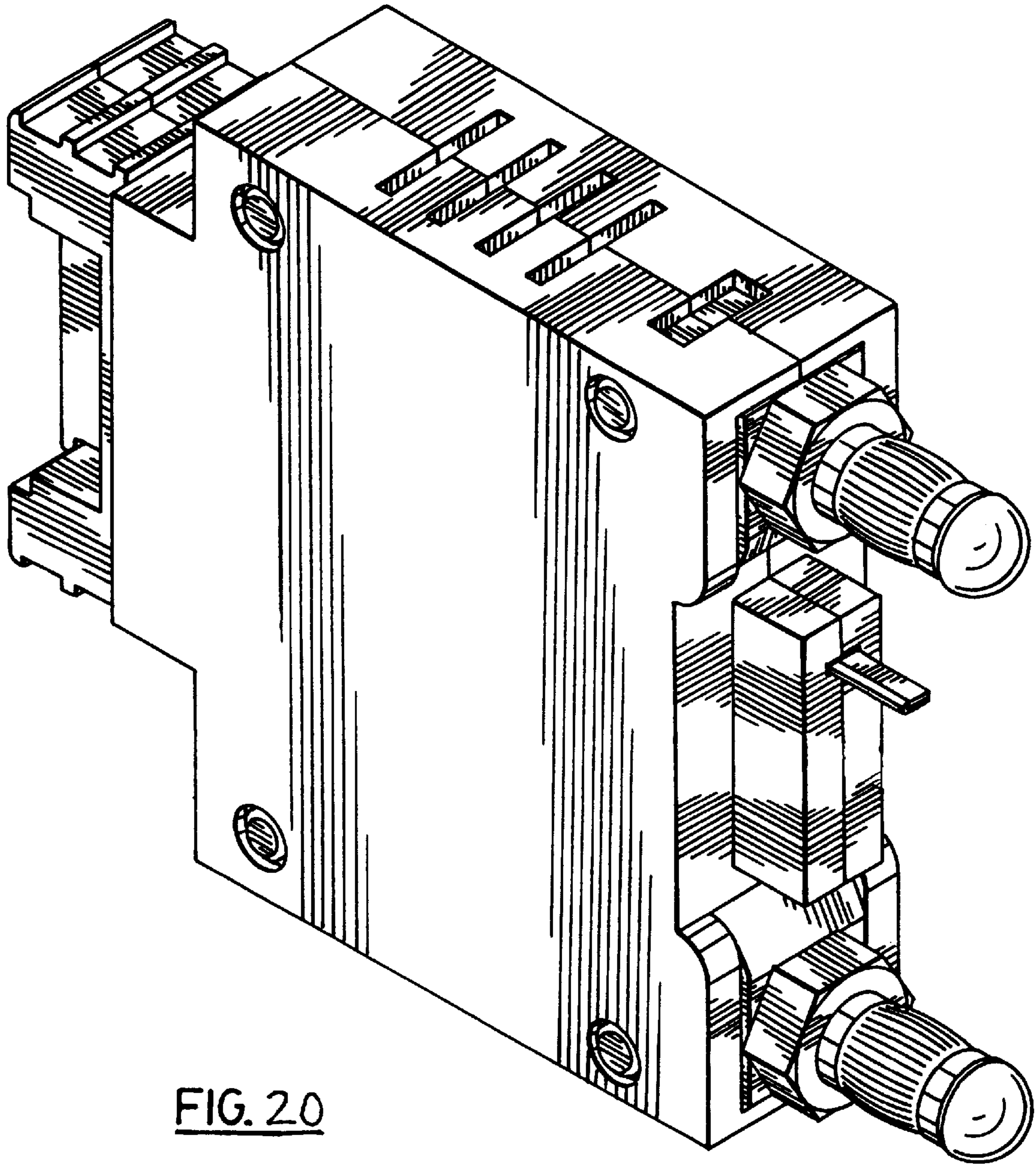

FIG. 20