



US00D452241B1

(12) **United States Design Patent**
Kitajima et al.

(10) **Patent No.:** **US D452,241 S**

(45) **Date of Patent:** **** Dec. 18, 2001**

(54) **IMAGE COMPRESSION TRANSMISSION CONTROL EQUIPMENT**

(75) Inventors: **Yasuhiro Kitajima; Sadaaki Miyamoto; Ou Matsumoto; Tsuneo Shimada**, all of Tokyo (JP)

(73) Assignee: **NEC Corporation**, Tokyo (JP)

(**) Term: **14 Years**

(21) Appl. No.: **29/133,452**

(22) Filed: **Dec. 1, 2000**

(30) **Foreign Application Priority Data**

Aug. 8, 2000 (JP) 2000-021847

(51) **LOC (7) Cl.** **14-02**

(52) **U.S. Cl.** **D14/358**

(58) **Field of Search** D14/354, 358, D14/368, 356, 357, 363; D13/162, 184, 199, 123; 382/259; 386/94; 380/51; 370/465; 707/4; 709/206, 217, 219, 227; 710/126; 717/11

(56) **References Cited**

U.S. PATENT DOCUMENTS

- D. 375,488 * 11/1996 Ikenaga D14/357
- D. 381,639 * 7/1997 Fraquelli et al. D14/354
- D. 381,647 * 7/1997 Terng D14/358
- D. 394,046 * 5/1998 Kurokawa D14/358

- D. 425,033 * 5/2000 Hibino D14/357
- D. 433,382 * 11/2000 Lytel D13/123
- 4,701,841 * 10/1987 Goodrich et al. 710/126
- 5,475,686 * 12/1995 Bach et al. 370/465
- 6,038,598 * 3/2000 Danneels 709/219
- 6,081,835 * 6/2000 Antcliff et al. 709/217
- 6,096,096 * 8/2000 Murphy et al. 717/11
- 6,131,122 * 10/2000 Sampson 709/227
- 6,154,738 * 11/2000 Call 707/4

* cited by examiner

Primary Examiner—Freda Nunn

(74) *Attorney, Agent, or Firm*—Sughrue, Mion, Zinn, Macpeak & Seas, PLLC

(57) **CLAIM**

The ornamental design for image compression transmission control equipment, as shown.

DESCRIPTION

FIG. 1 is a perspective view of the top, front and right side of image compression transmission control equipment showing our new design;

FIG. 2 is a front elevational view thereof;

FIG. 3 is a rear elevational view thereof;

FIG. 4 is a left side elevational view thereof;

FIG. 5 is a right side elevational view thereof;

FIG. 6 is a top plan view thereof; and,

FIG. 7 is a bottom plan view thereof.

1 Claim, 3 Drawing Sheets

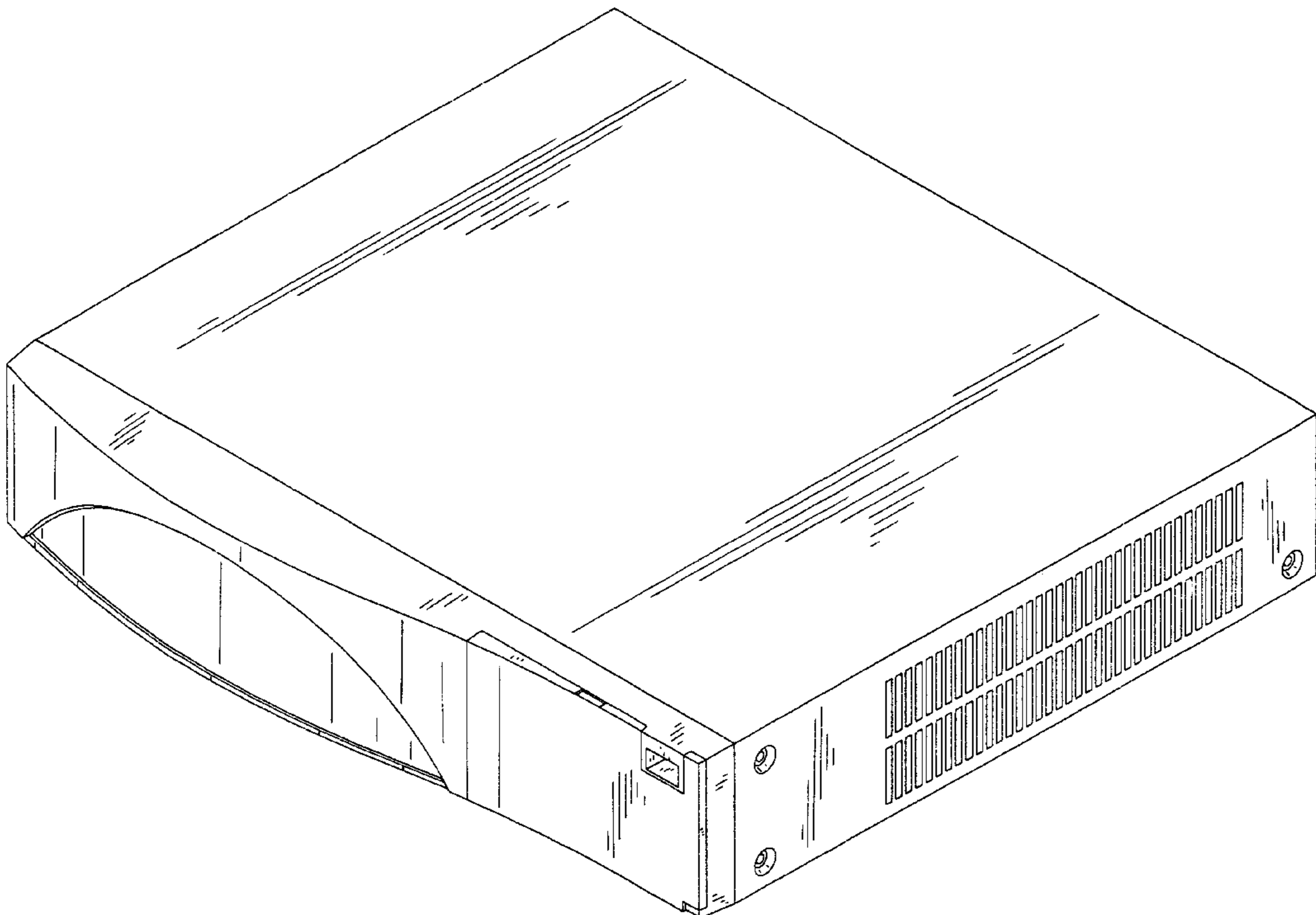

FIG. 1

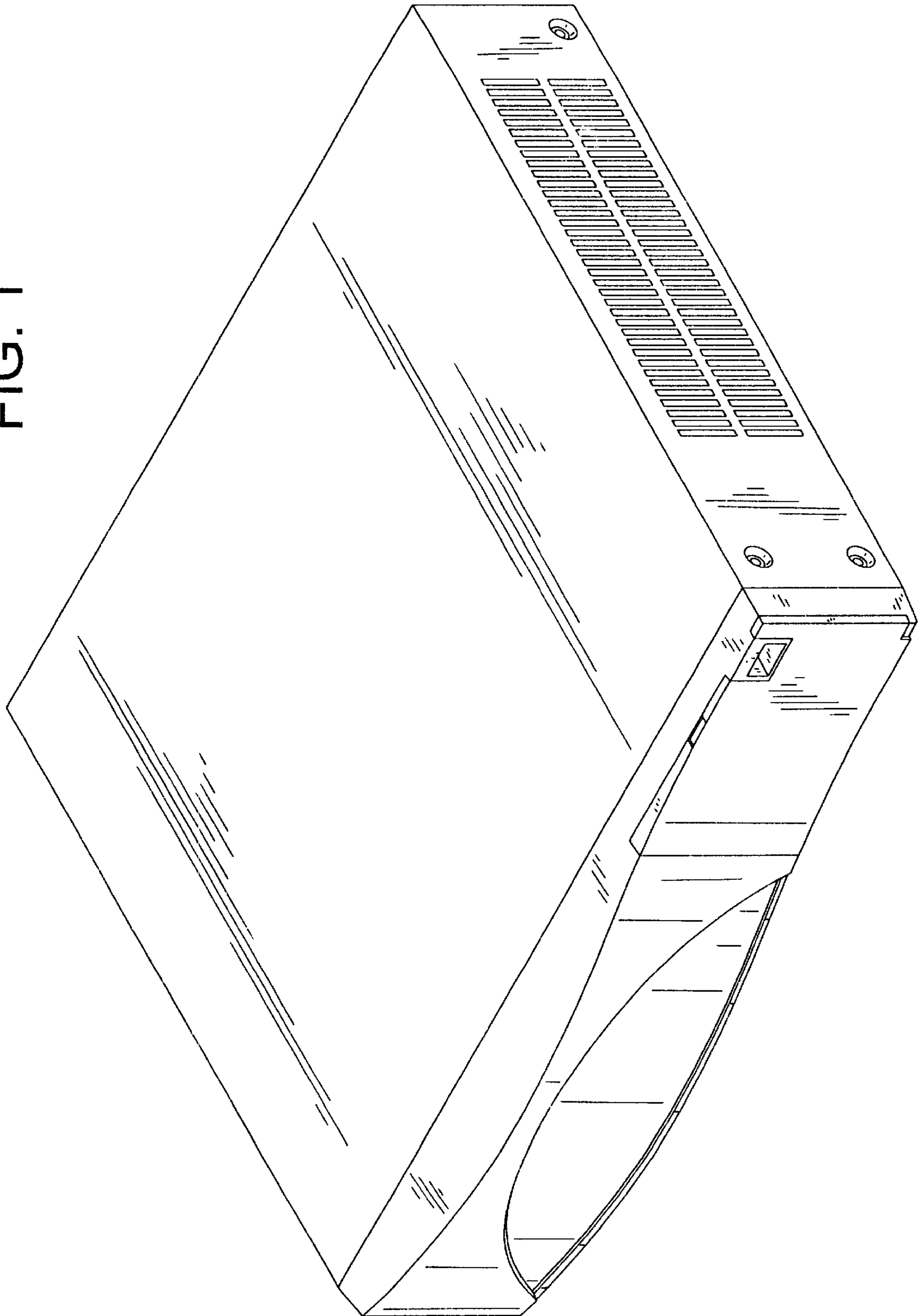

FIG. 2

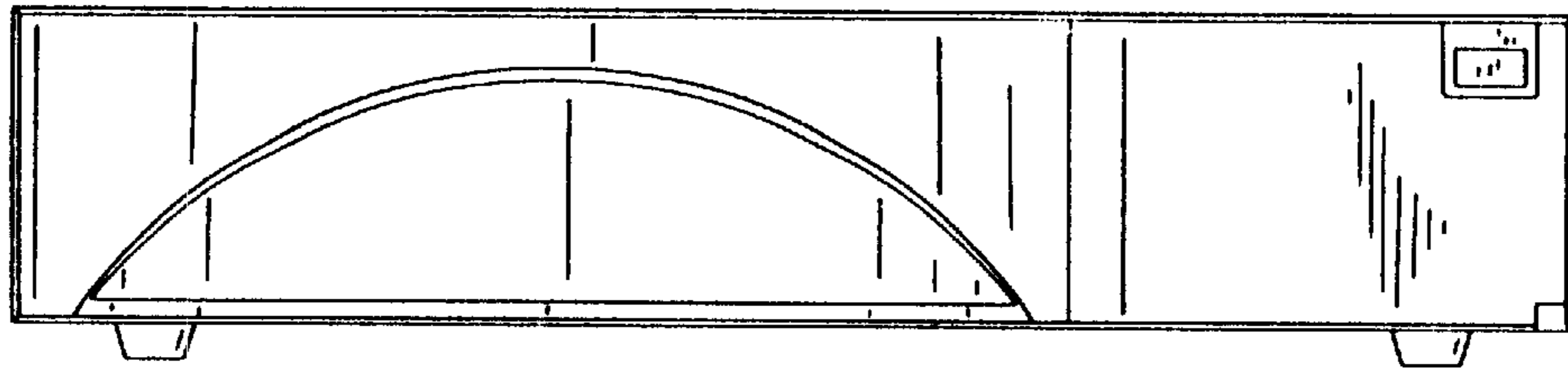

FIG. 3

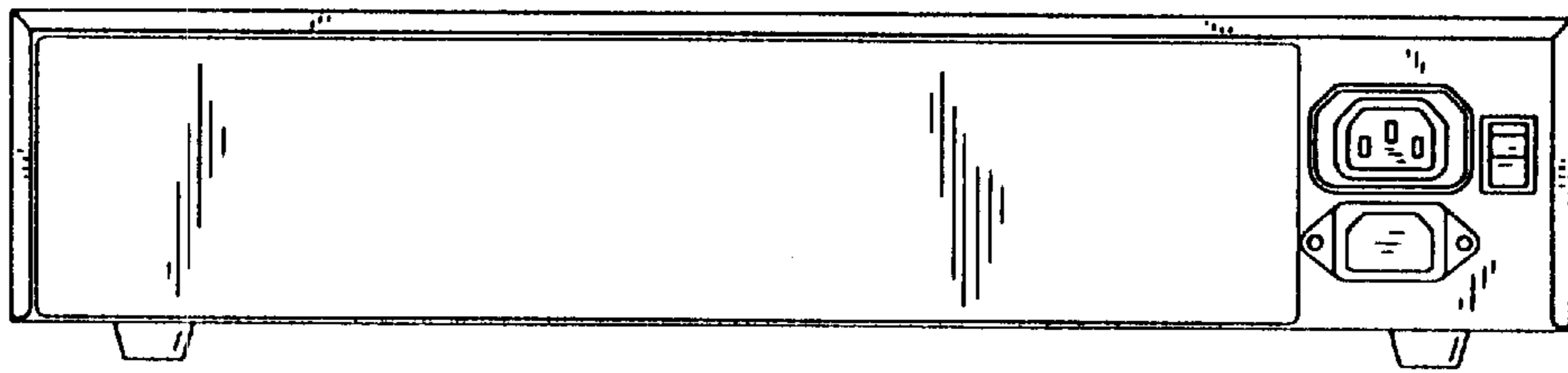

FIG. 4

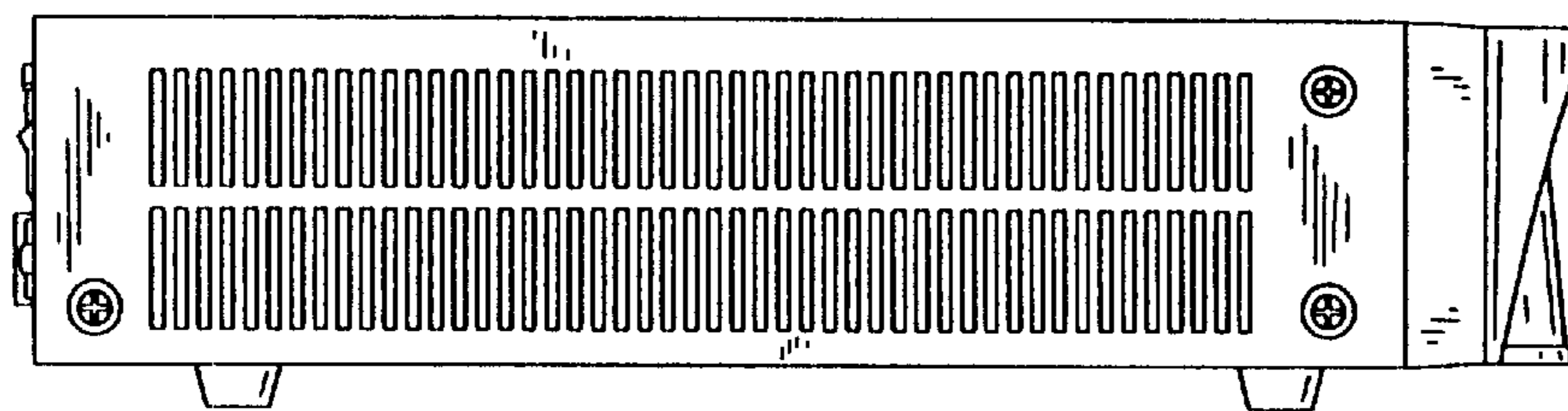

FIG. 5

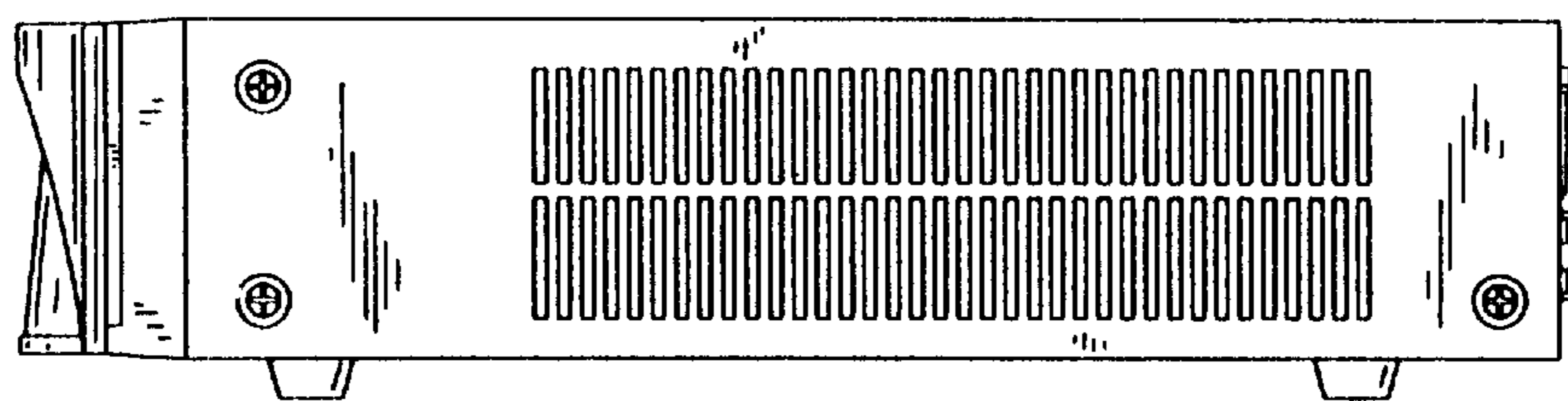

FIG. 6

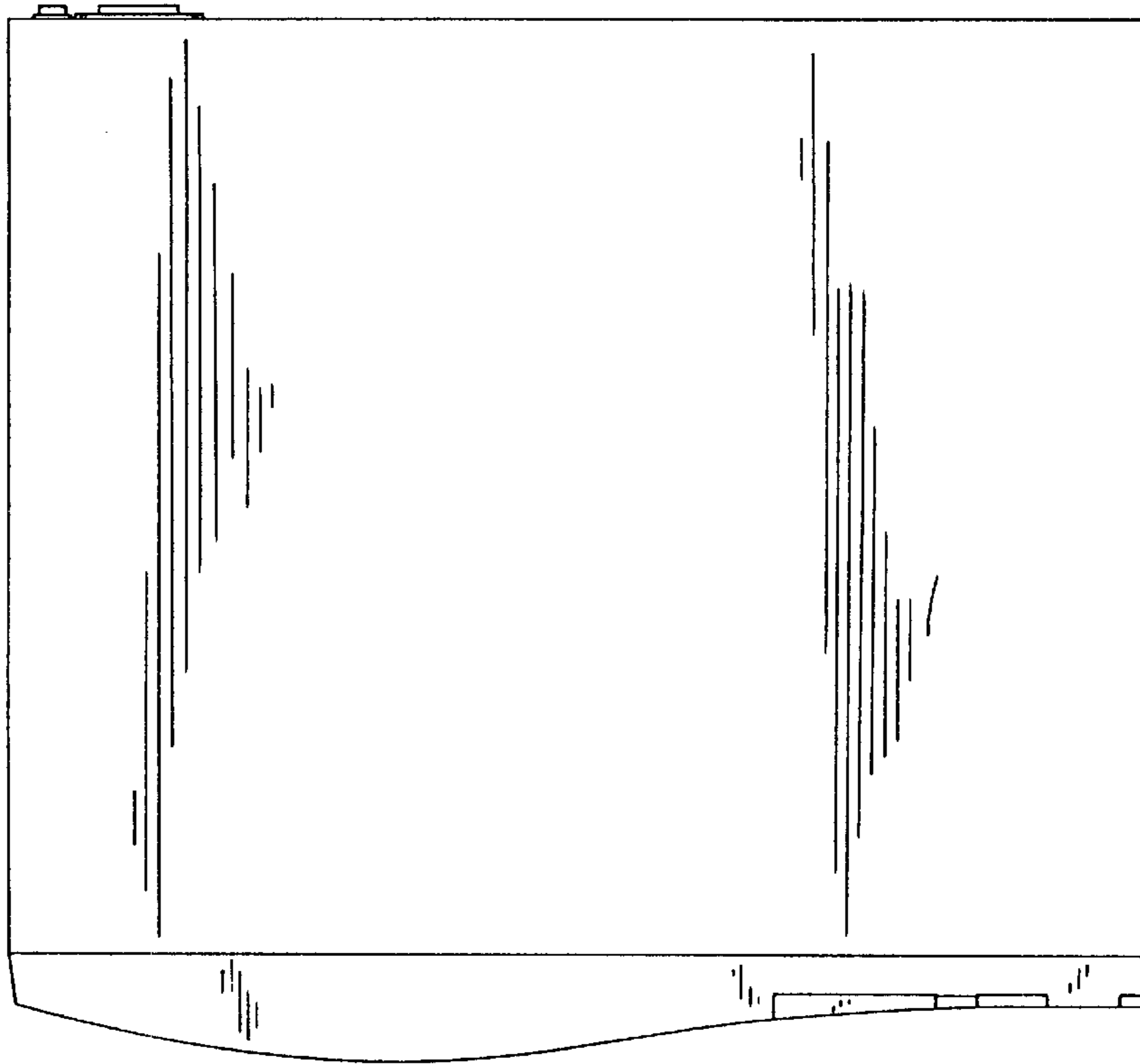

FIG. 7

