



US00D452085B1

(12) **United States Design Patent**
Chang

(10) **Patent No.:** **US D452,085 S**

(45) **Date of Patent:** **** Dec. 18, 2001**

(54) **OFFICE DESK**

(76) Inventor: **Chien-Kuo Chang**, Fl. 10-2, No. 447,
Sec. 3, Wen-Hsin Rd., Taichung (TW)

(**) Term: **14 Years**

(21) Appl. No.: **29/140,528**

(22) Filed: **Apr. 20, 2001**

(51) **LOC (7) Cl.** **06-04**

(52) **U.S. Cl.** **D6/422**

(58) **Field of Search** D6/422-428, 484,
D6/477, 474; 312/194-196, 208.1; 108/50.01,
50.02

(56) **References Cited**

U.S. PATENT DOCUMENTS

- D. 258,787 * 4/1981 Verdesca D6/422
- D. 270,025 * 8/1983 Koves D6/422
- D. 329,551 * 9/1992 Lechman D6/422

* cited by examiner

Primary Examiner—Janice E. Seeger

(74) *Attorney, Agent, or Firm*—Rosenberg, Klein & Lee

(57) **CLAIM**

The ornamental design for office desk, as shown and described.

DESCRIPTION

FIG. 1 is a perspective view of office desk showing my new design;

FIG. 2 is a front elevational view thereof;

FIG. 3 is a rear elevational view thereof;

FIG. 4 is a left side elevational view thereof;

FIG. 5 is a right side elevational view thereof;

FIG. 6 is a top side elevational view thereof; and,

FIG. 7 is a bottom side elevational view thereof.

1 Claim, 5 Drawing Sheets

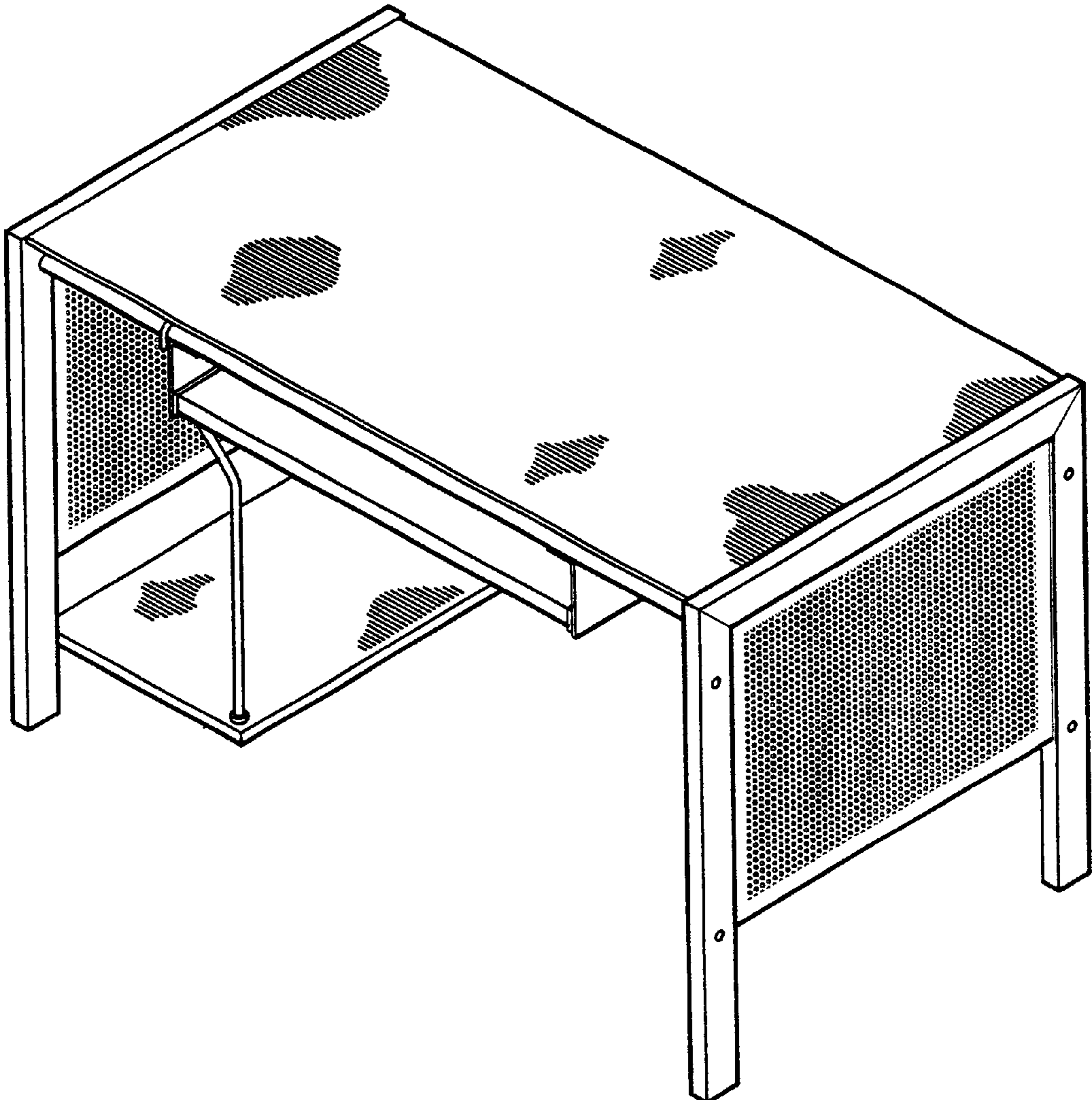

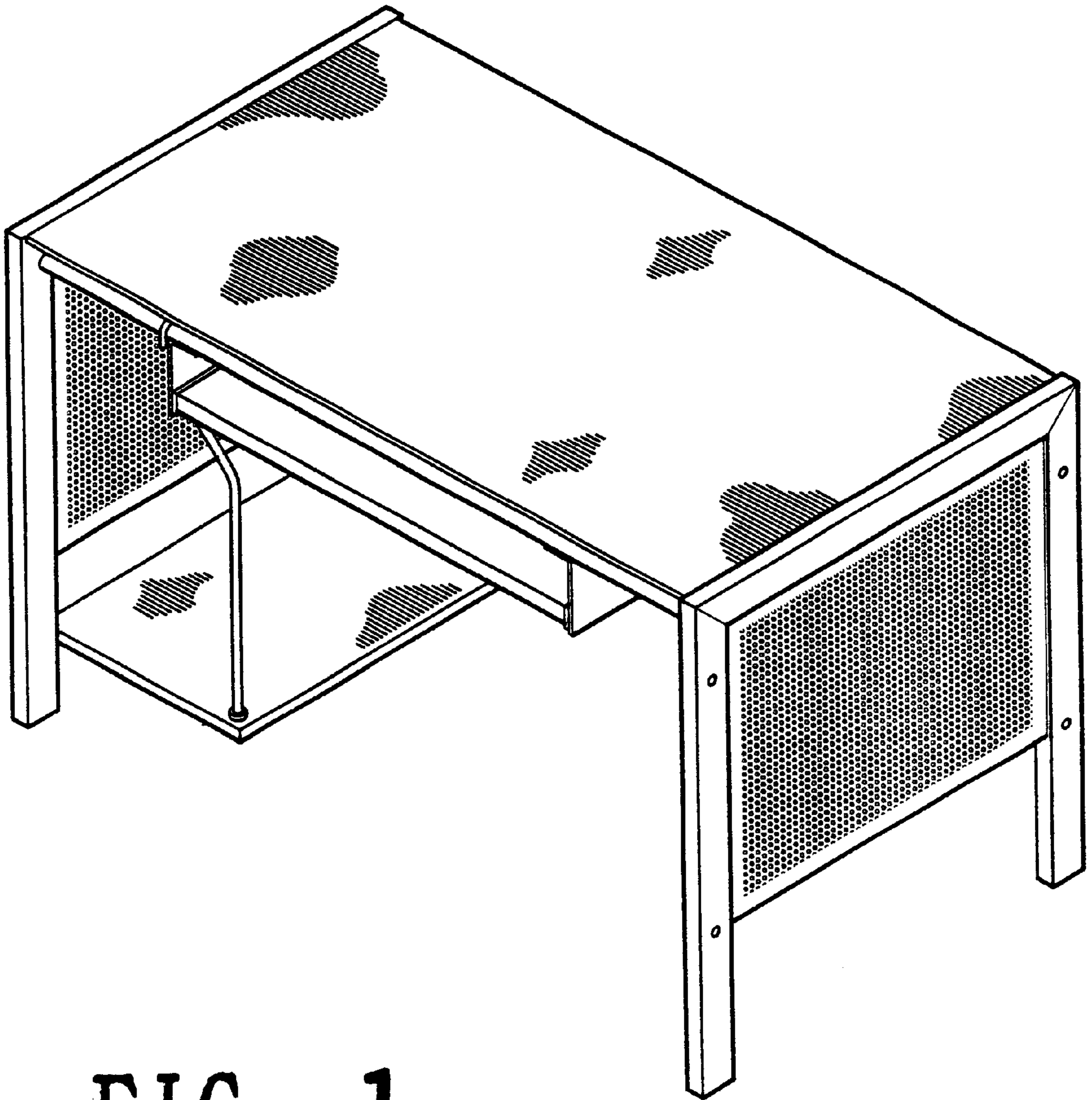

FIG. 1

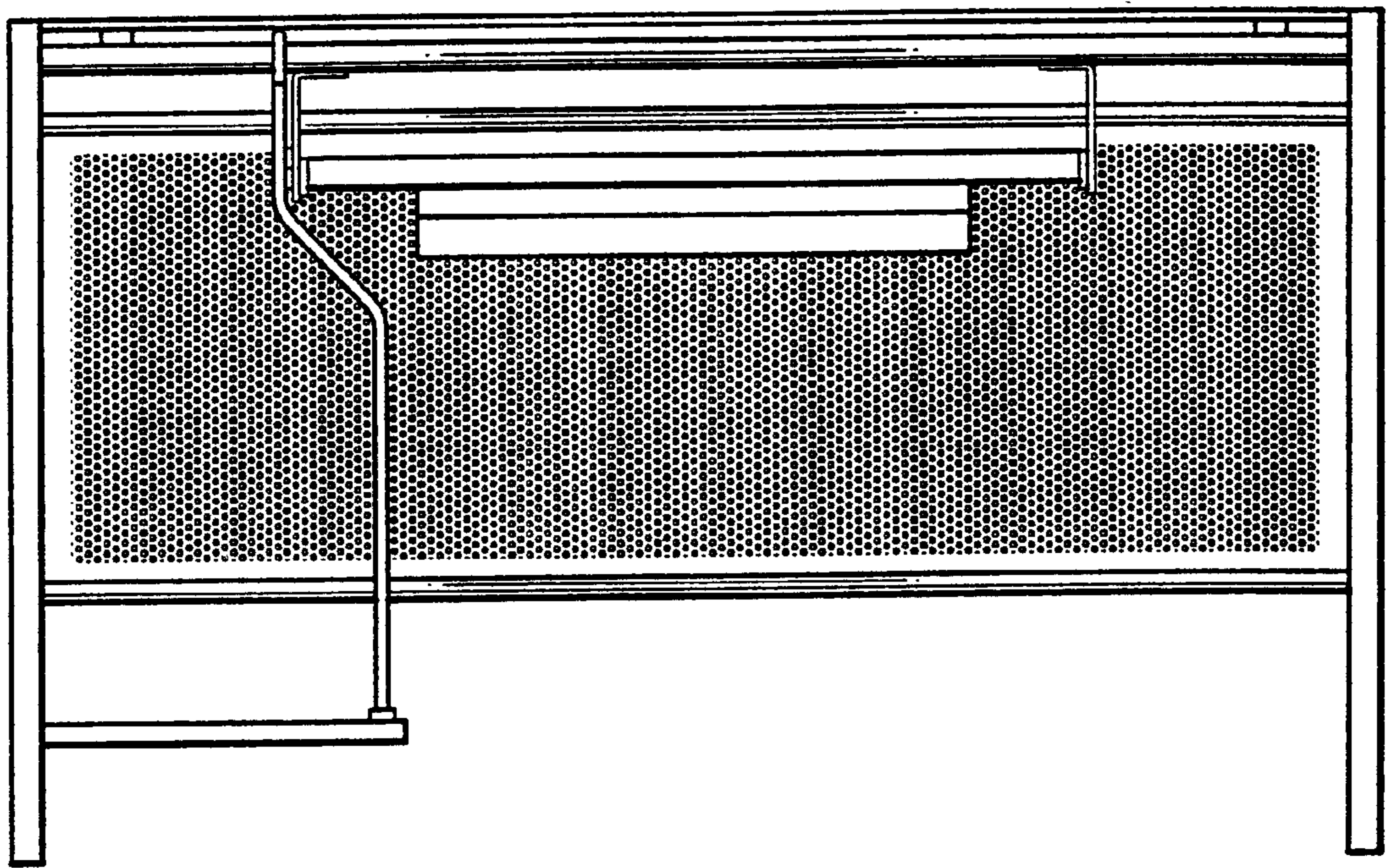

FIG. 2

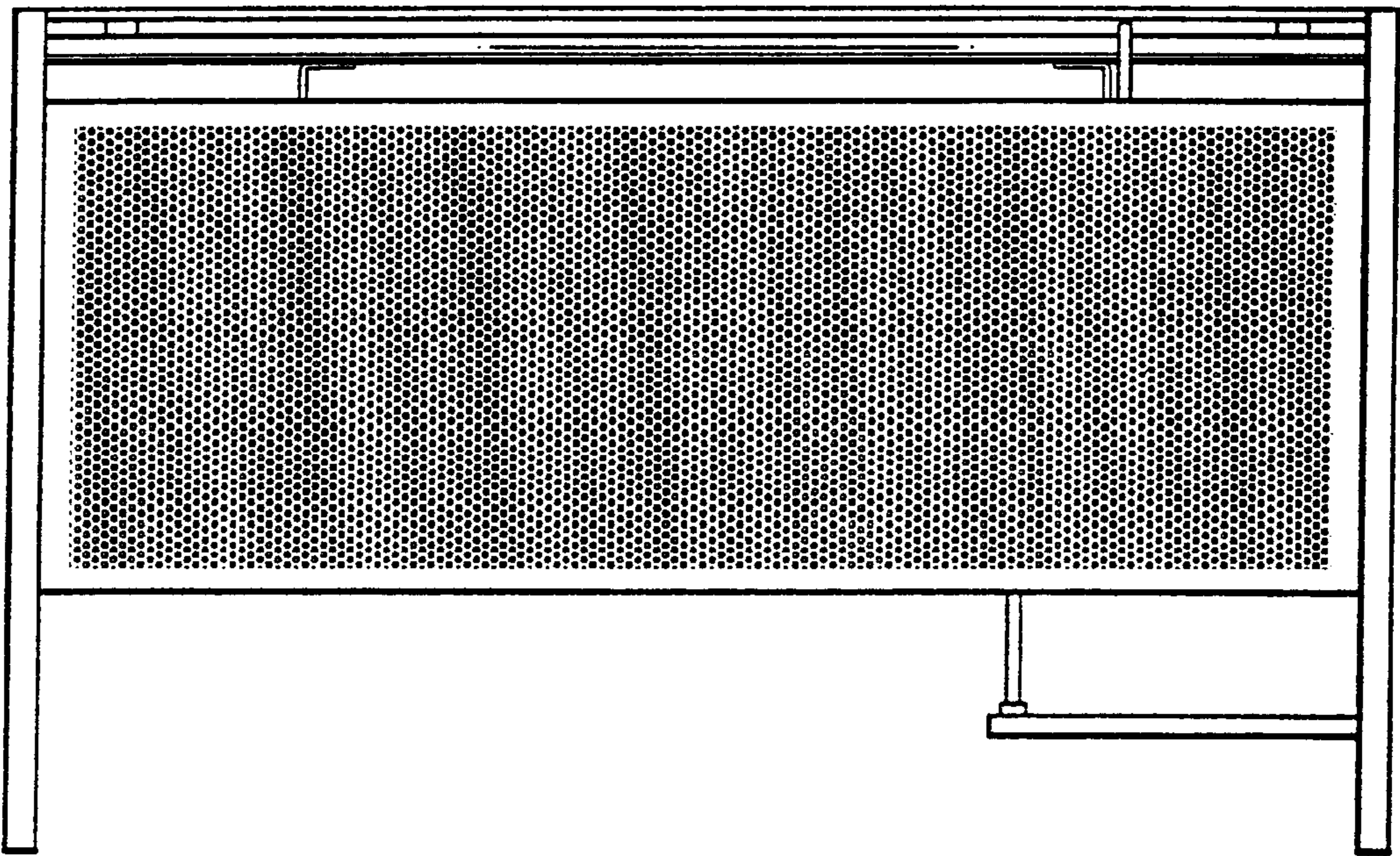

FIG. 3

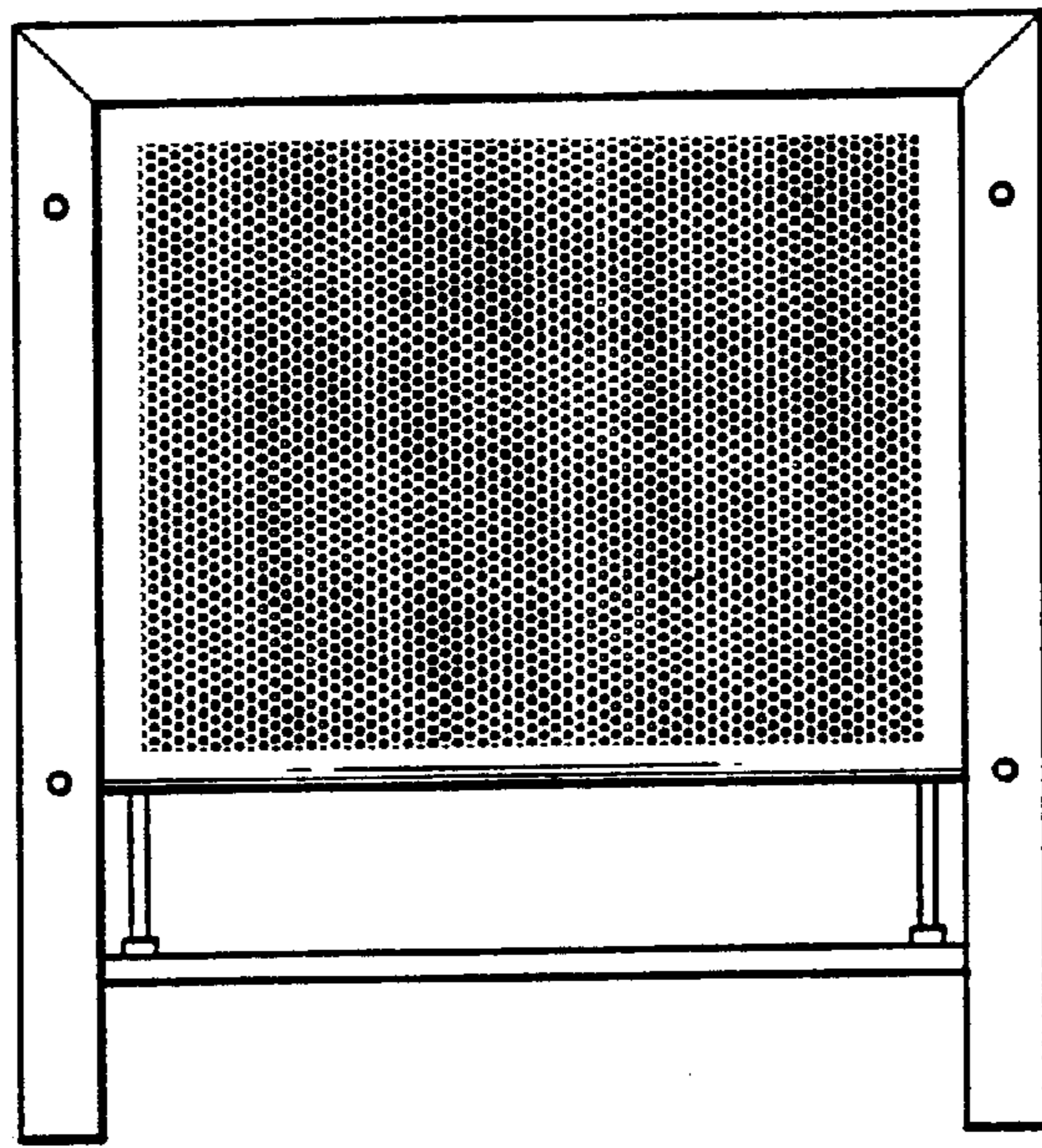

FIG. 4

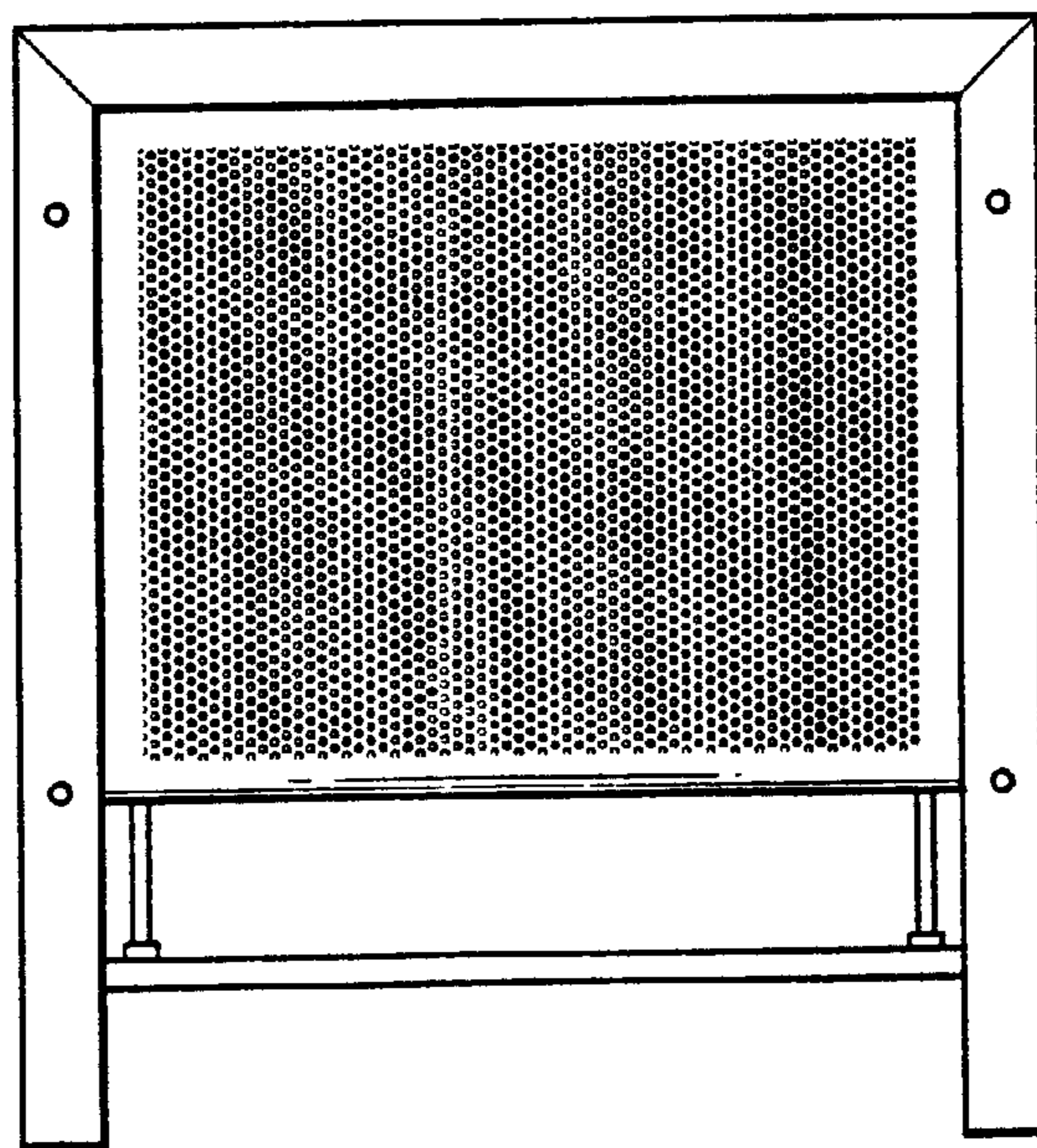

FIG. 5

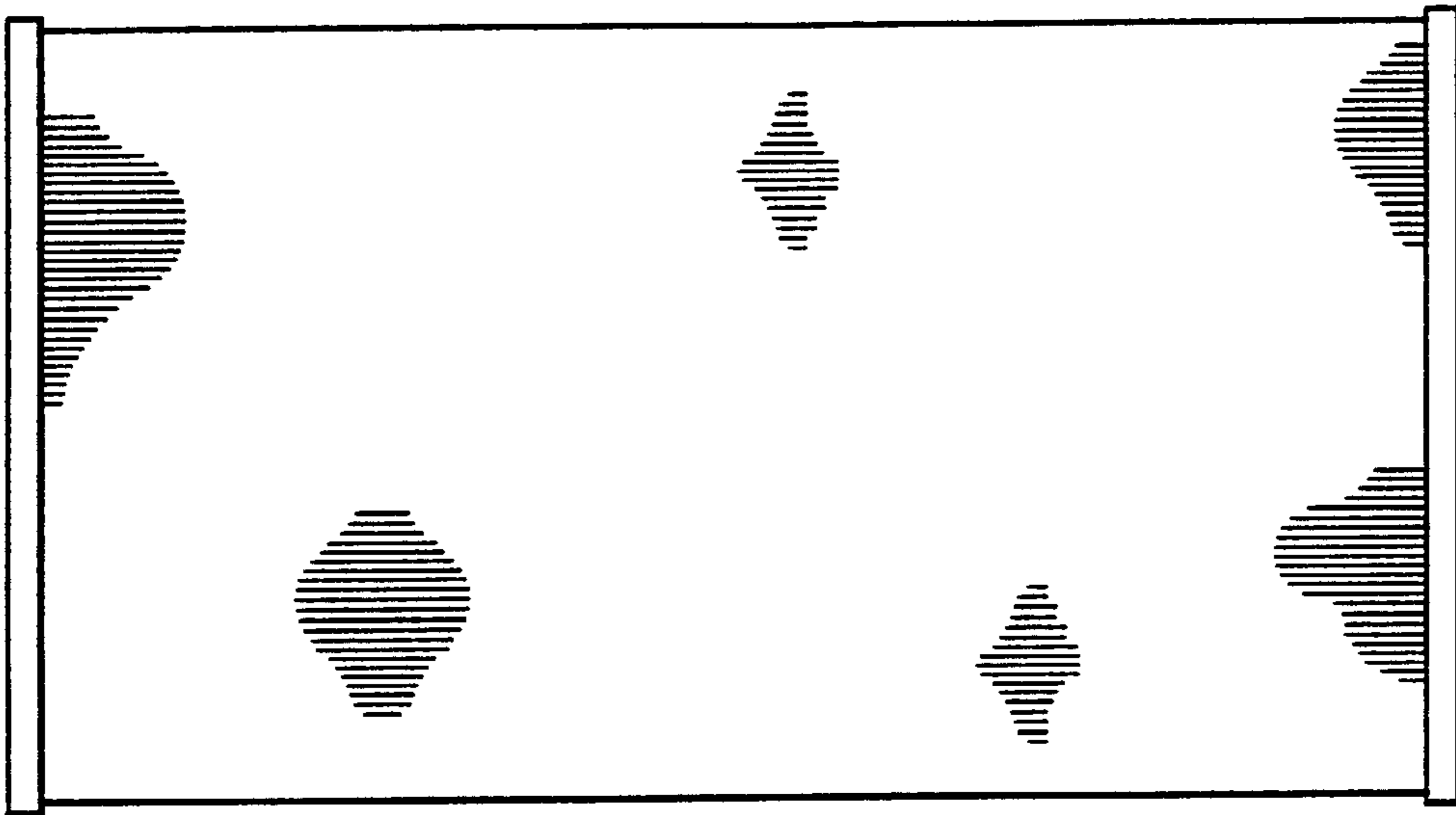

FIG. 6

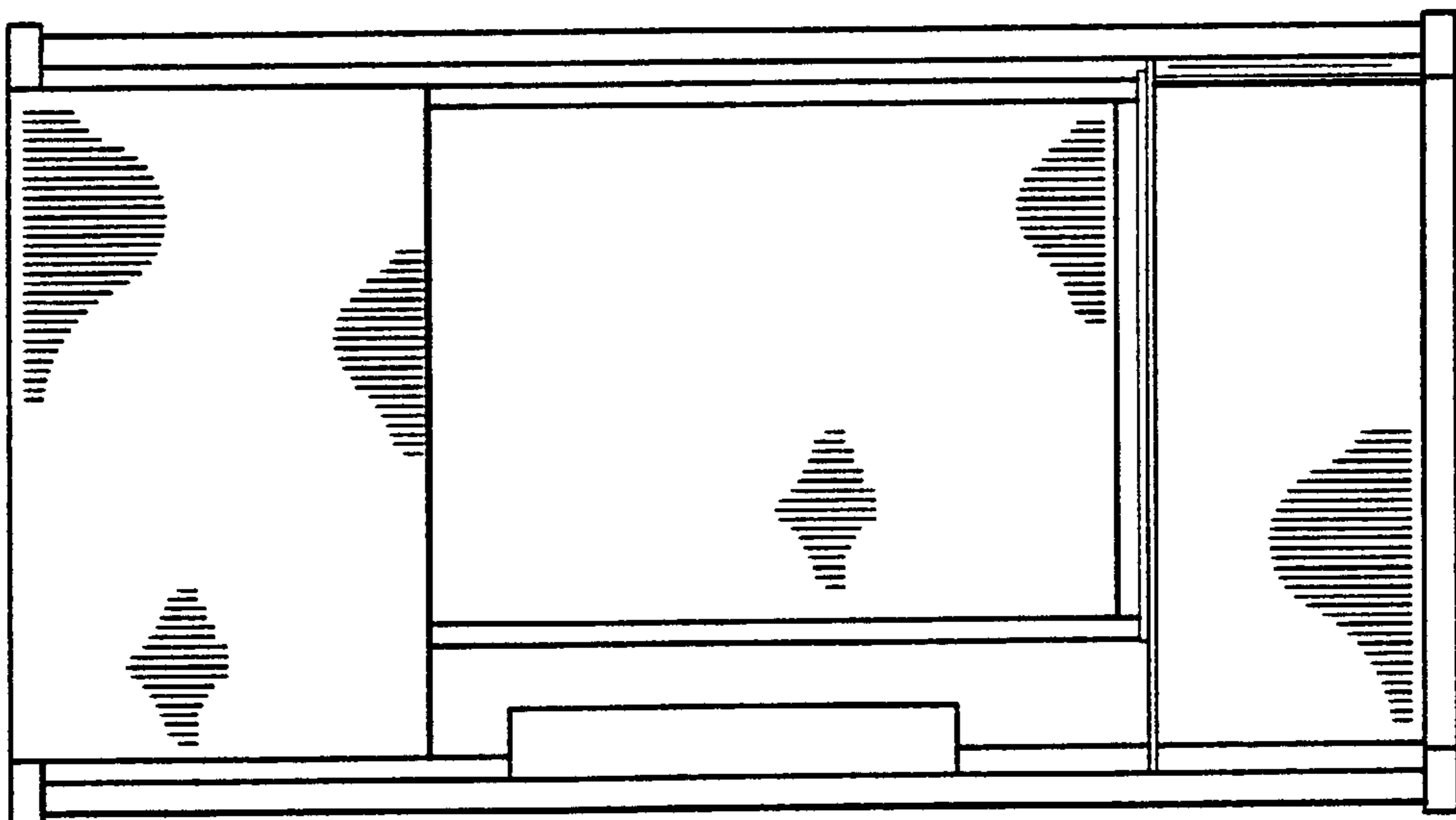

FIG. 7