



US00D451959B1

(12) **United States Design Patent**
Velasquez

(10) **Patent No.:** **US D451,959 S**

(45) **Date of Patent:** **** Dec. 11, 2001**

(54) **ADHESIVE TRANSFER APPARATUS**

(75) Inventor: **Joseph P. E. Velasquez**, Gilbert, AZ (US)

(73) Assignee: **Xyron, Inc.**, Scottsdale, AZ (US)

(**) Term: **14 Years**

(21) Appl. No.: **29/137,891**

(22) Filed: **Mar. 2, 2001**

(51) **LOC (7) Cl.** **19-02**

(52) **U.S. Cl.** **D19/67**

(58) **Field of Search** D19/65-70; 156/523, 156/527, 540, 576, 577; 206/395-398, 411, 415; 225/6-7, 9, 25, 34, 45-46, 56, 65, 77, 89; 242/588.1-588.6, 590; 312/34.8; D18/24, 29, 99

(56) **References Cited**

U.S. PATENT DOCUMENTS

- D. 386,524 * 11/1997 Walker D19/65
- 3,983,814 * 10/1976 Baker D18/24

* cited by examiner

Primary Examiner—Doris V. Coles
Assistant Examiner—Elizabeth A. Albert

(74) *Attorney, Agent, or Firm*—Pillsbury Winthrop LLP

(57) **CLAIM**

The ornamental design for an adhesive transfer apparatus, as shown and described.

DESCRIPTION

A portion of the disclosure of this patent document contains material to which a claim for copyright is made. The copyright owner has no objection to the facsimile reproduction of the patent document or the patent disclosure, as it appears in the Patent and Trademark Office patent file or records, but reserves all other copyrights whatsoever.

FIG. 1 is a perspective view of an adhesive transfer apparatus, looking downwardly at a front and left side thereof; FIG. 2 is a right elevational view of the adhesive transfer apparatus of FIG. 1;

FIG. 3 is a left elevational view of the adhesive transfer apparatus of FIG. 1;

FIG. 4 is a front elevational view of the adhesive transfer apparatus of FIG. 1;

FIG. 5 is a rear elevational view of the adhesive transfer apparatus of FIG. 1;

FIG. 6 is top plan view of the adhesive transfer apparatus of FIG. 1; and,

FIG. 7 is bottom plan view of the adhesive transfer apparatus of FIG. 1.

1 Claim, 5 Drawing Sheets

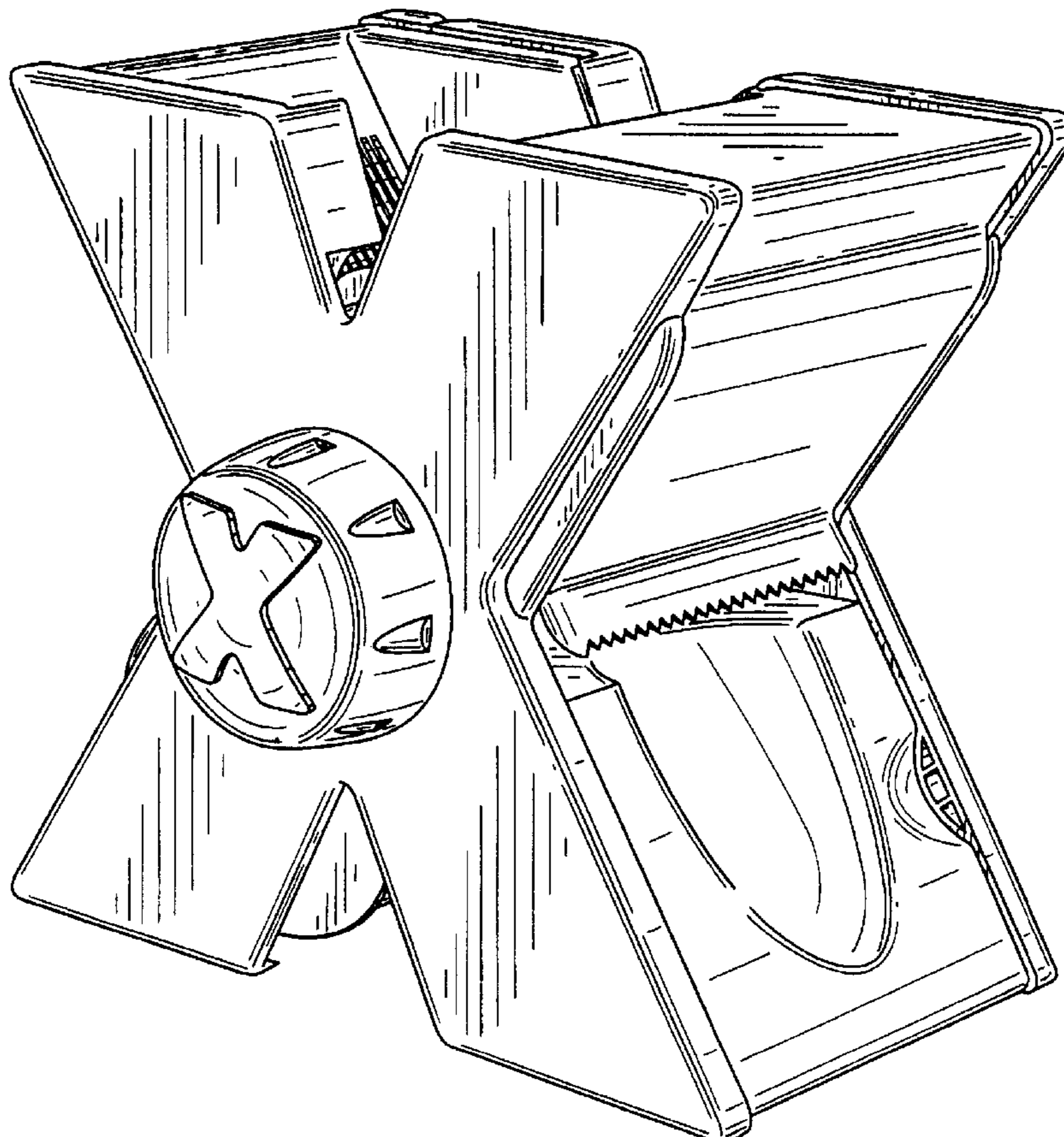

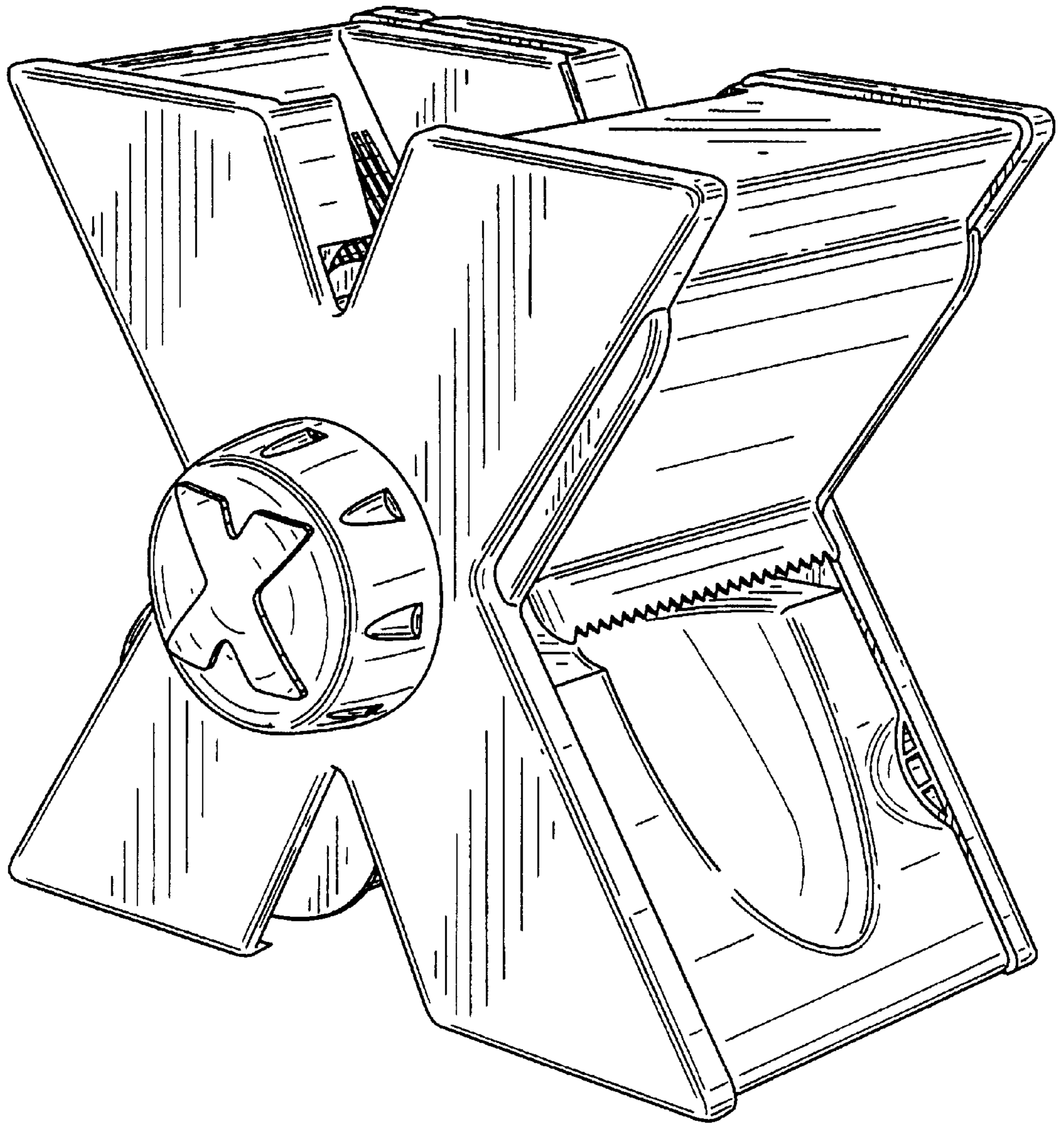

FIG. 1

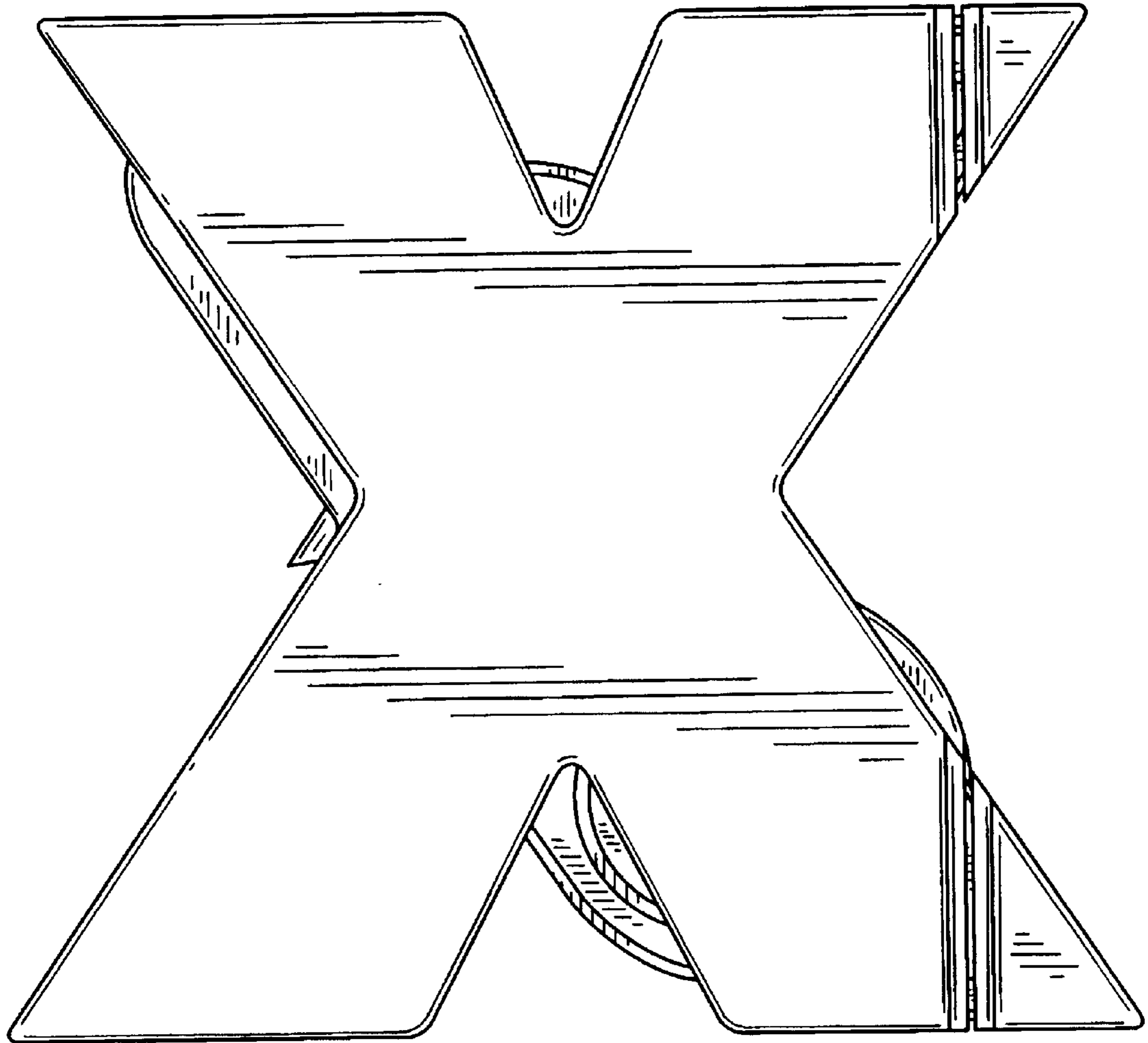

FIG. 2

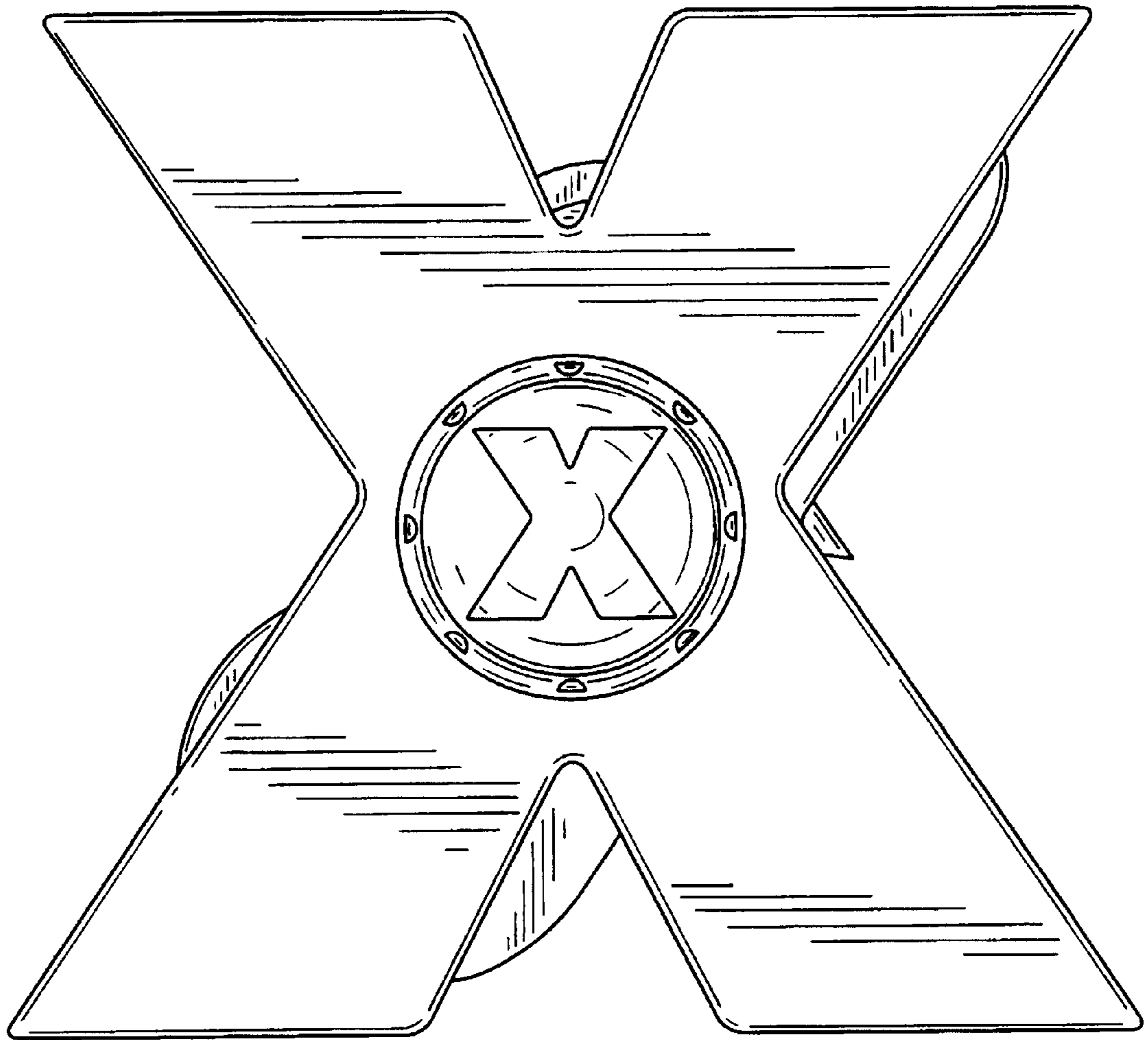

FIG. 3

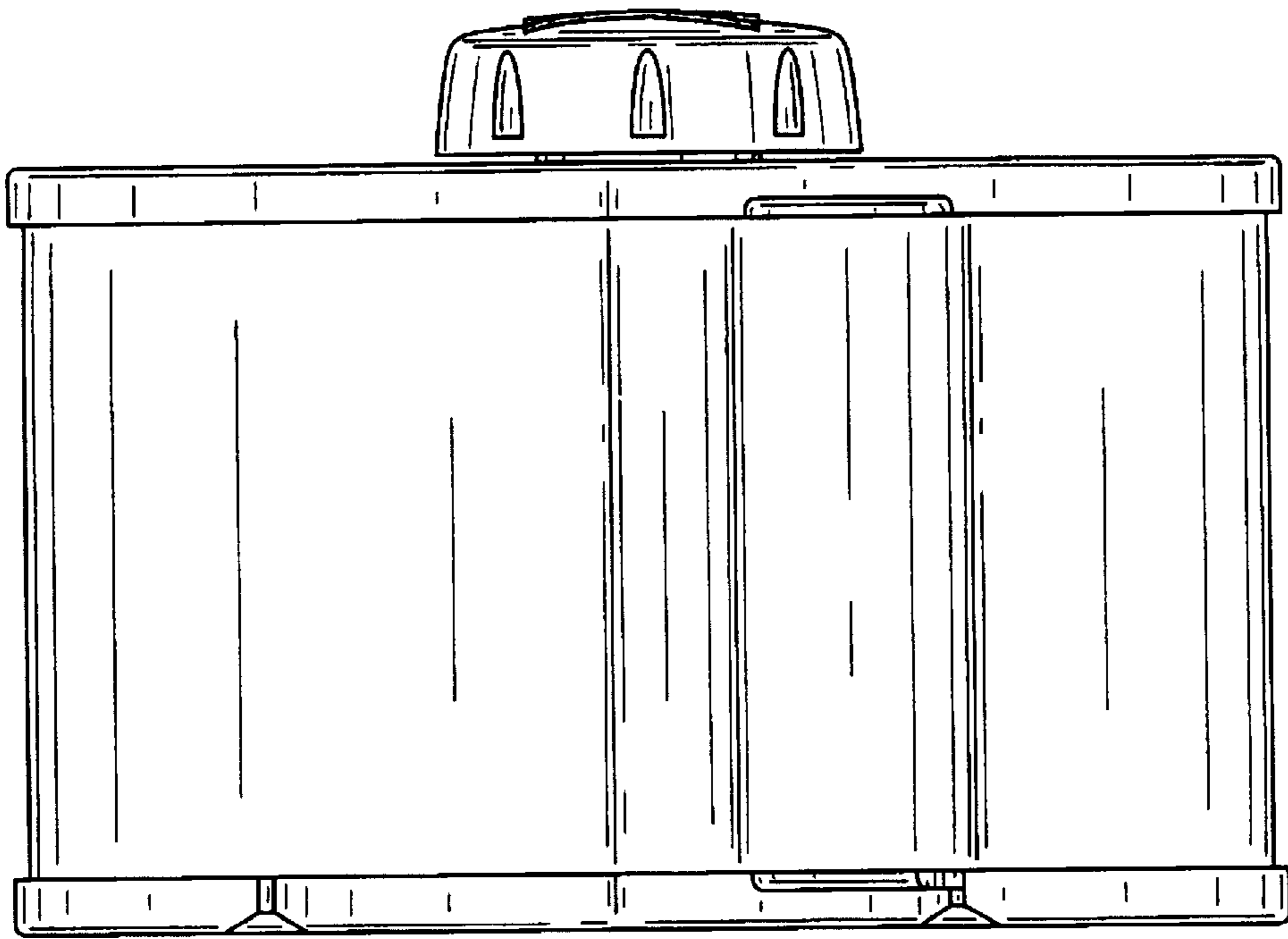

FIG. 5

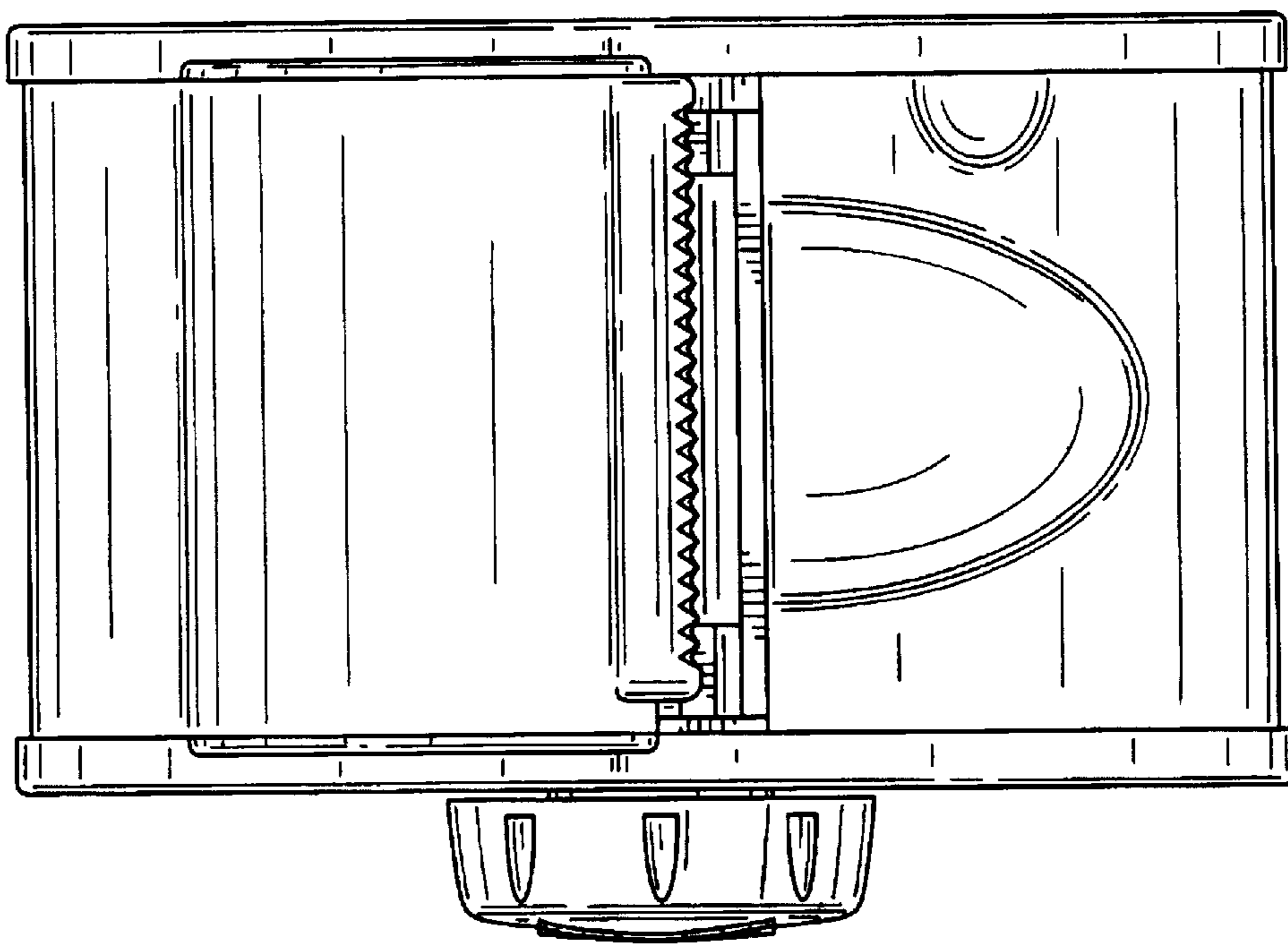

FIG. 4

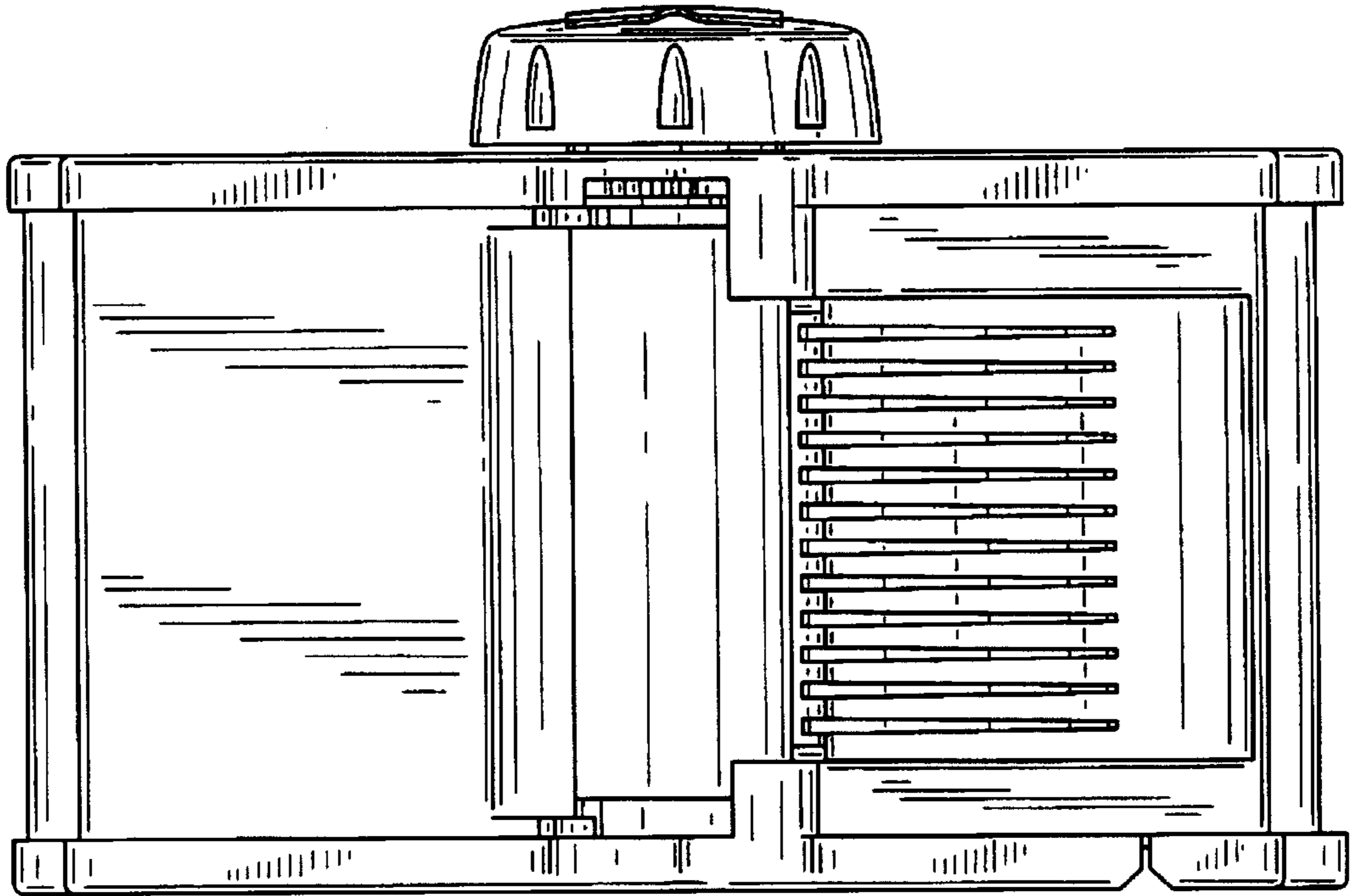

FIG. 6

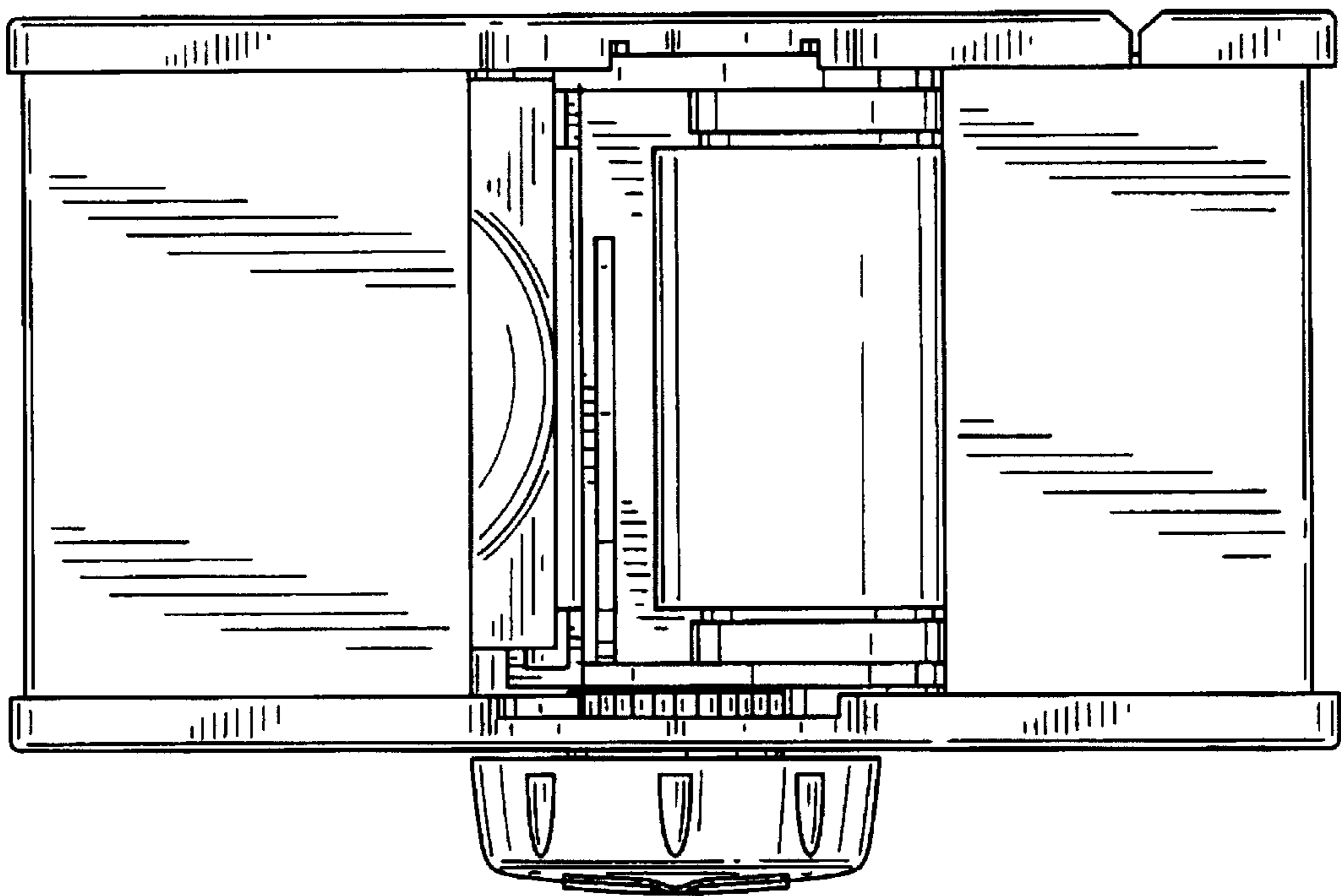

FIG. 7