



US00D451879B1

(12) **United States Design Patent**  
**Fraser**

(10) **Patent No.:** **US D451,879 S**

(45) **Date of Patent:** **\*\* Dec. 11, 2001**

(54) **AIRCRAFT**

*Primary Examiner*—Marcus A. Jackson

(76) **Inventor:** **Norman Thomas Laurence Fraser,**  
4597 Candleberry Ave., Seal Beach, CA  
(US) 90740-3026

(57) **CLAIM**

The ornamental design for a aircraft, as shown and described.

(\*\*) **Term:** **14 Years**

**DESCRIPTION**

(21) **Appl. No.:** **29/140,581**

FIG. 1 is a left side perspective view of a first twin engine embodiment of an aircraft showing my new design.

(22) **Filed:** **Apr. 23, 2001**

FIG. 2 is a left side elevation view thereof.

(51) **LOC (7) Cl.** ..... **12-07**

(52) **U.S. Cl.** ..... **D12/319**

FIG. 3 is a front elevational view thereof. This view also applies to my second twin engine aircraft.

(58) **Field of Search** ..... D12/319-345;  
244/45 R, 45 A, 15, 55, 91, 199

FIG. 4 is a top plan view thereof.

(56) **References Cited**

FIG. 5 is a left side perspective view of a second twin engine embodiment of an aircraft showing my new design.

**U.S. PATENT DOCUMENTS**

FIG. 6 is a left side elevational view thereof; and,

D. 370,456 \* 6/1996 Buchsel et al. .... D12/319

D. 421,955 \* 3/2000 Birrenbach ..... D12/319

FIG. 7 is a top plan view thereof.

D. 426,804 \* 6/2000 Birrenbach ..... D12/319

\* cited by examiner

**1 Claim, 3 Drawing Sheets**

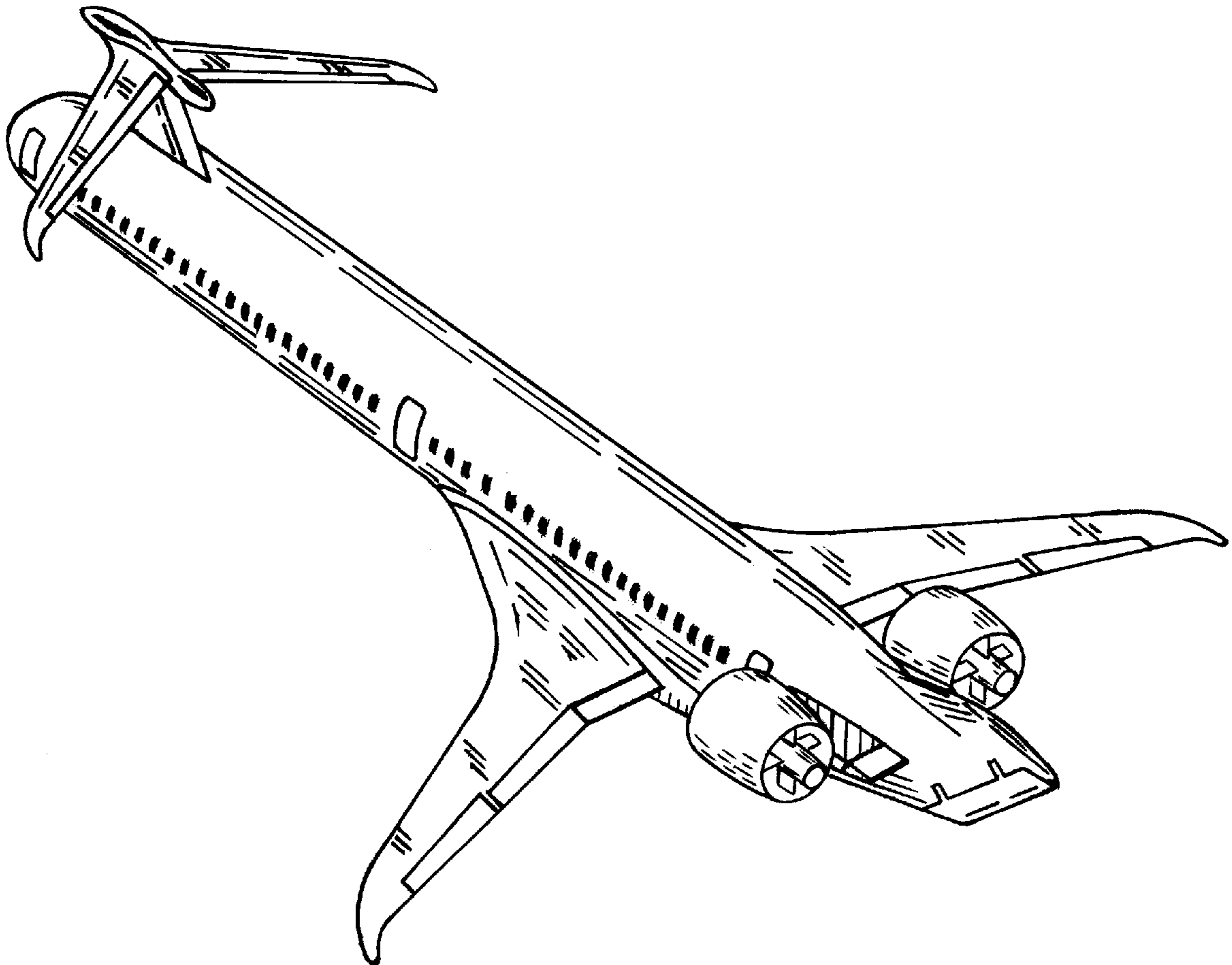

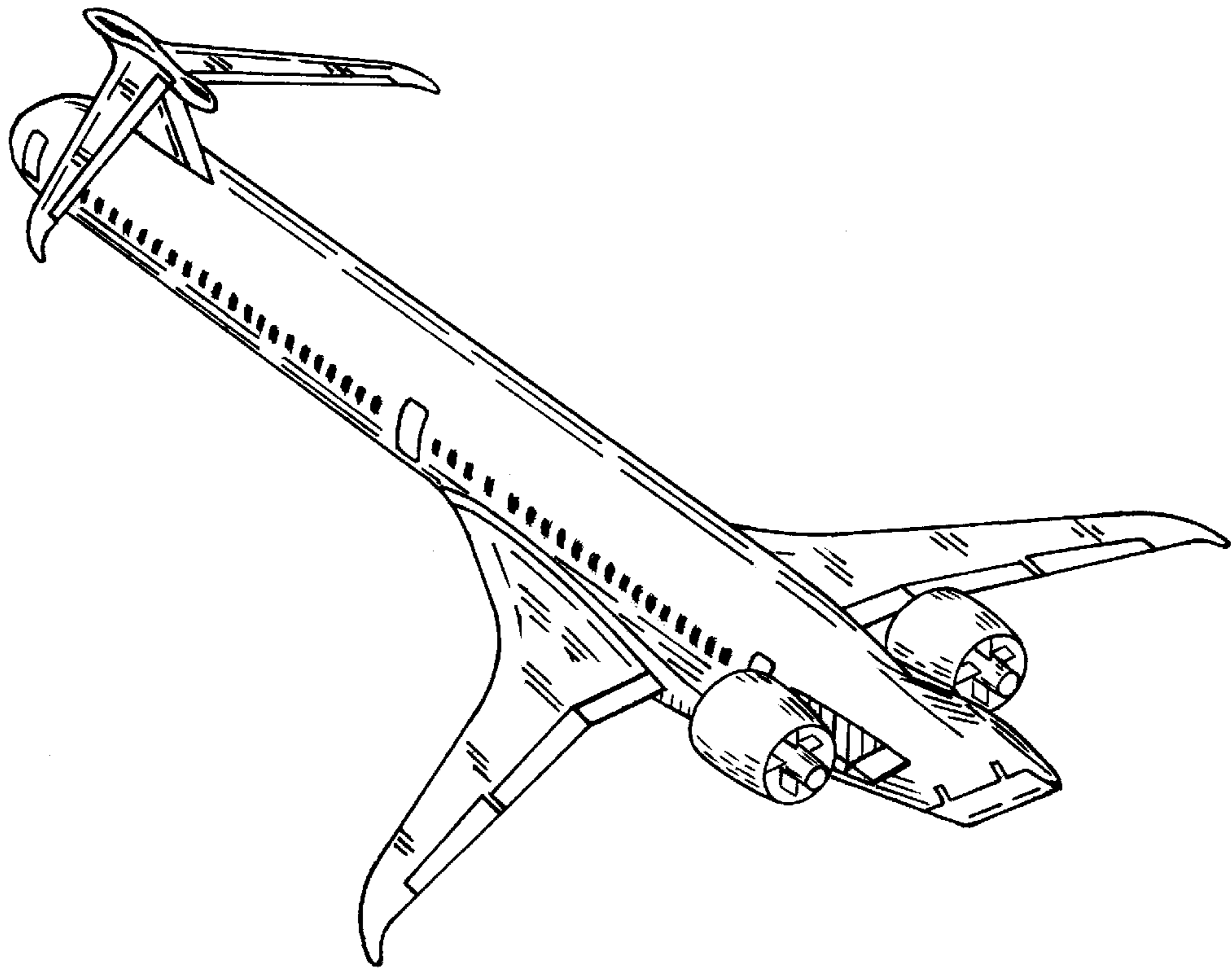

FIG. 1

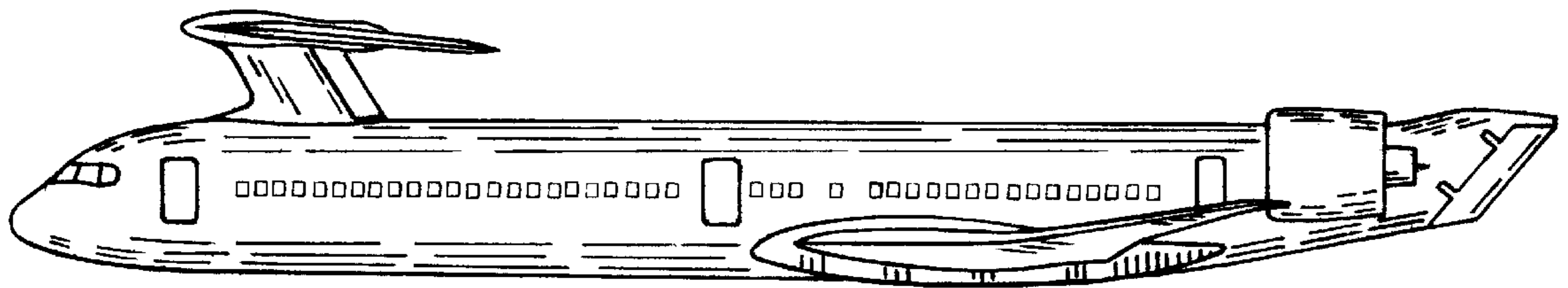

FIG. 2

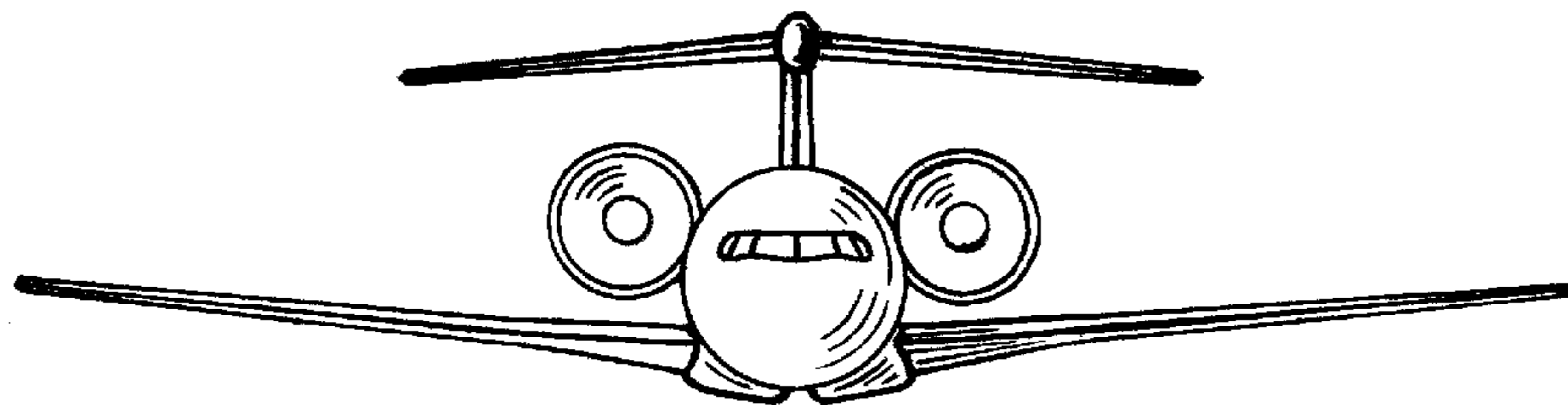

FIG. 3

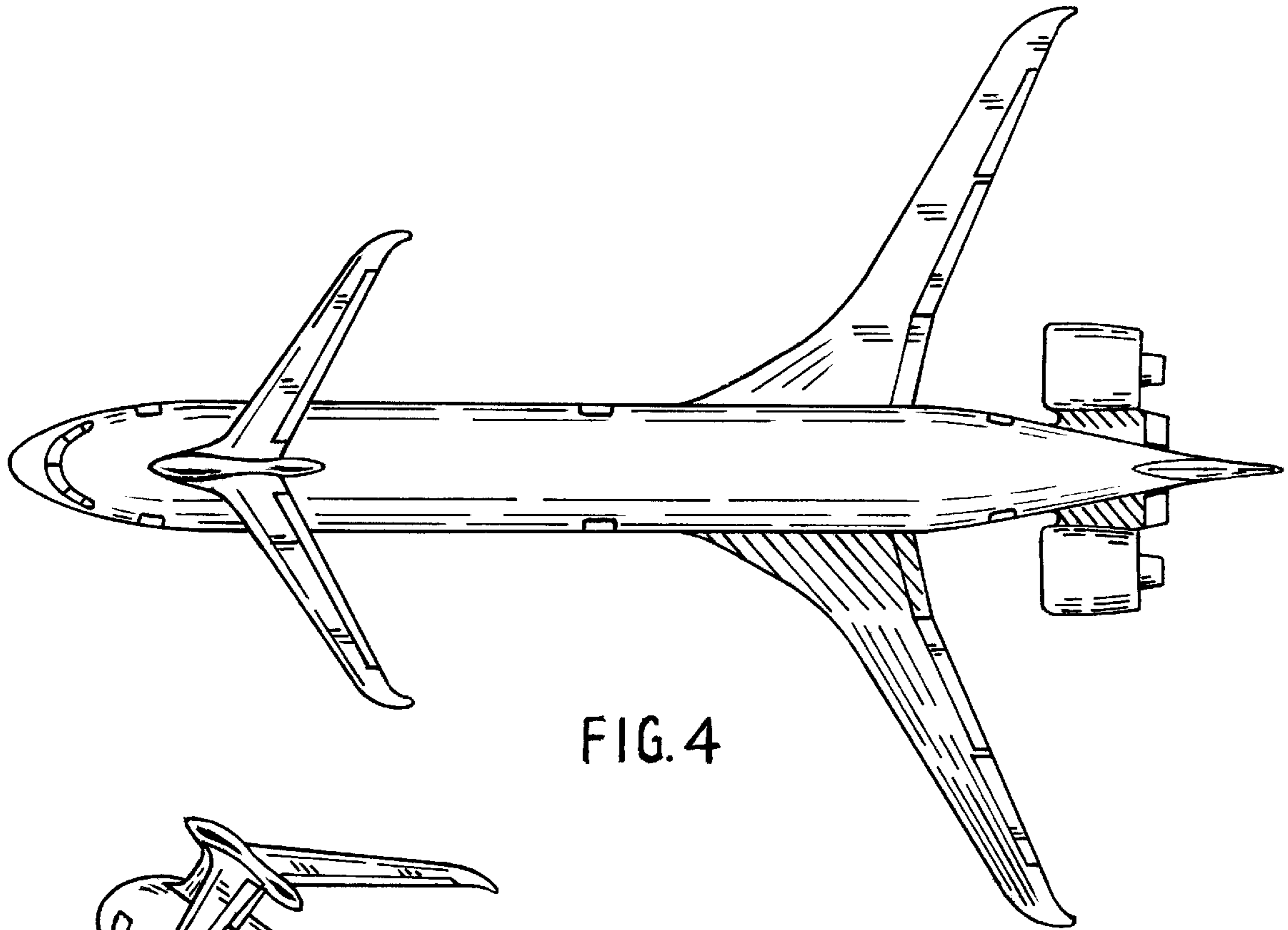

FIG. 4

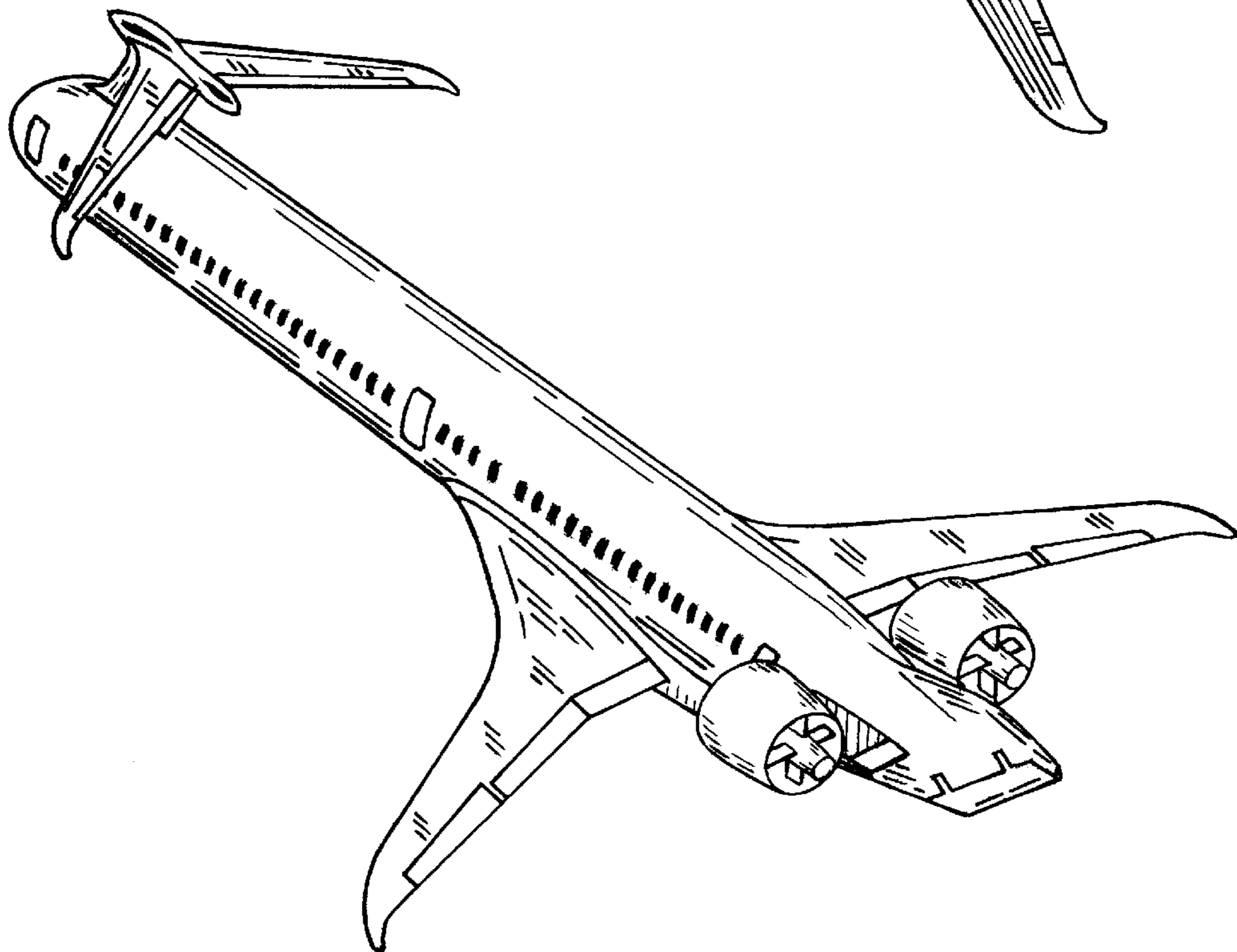

FIG. 5

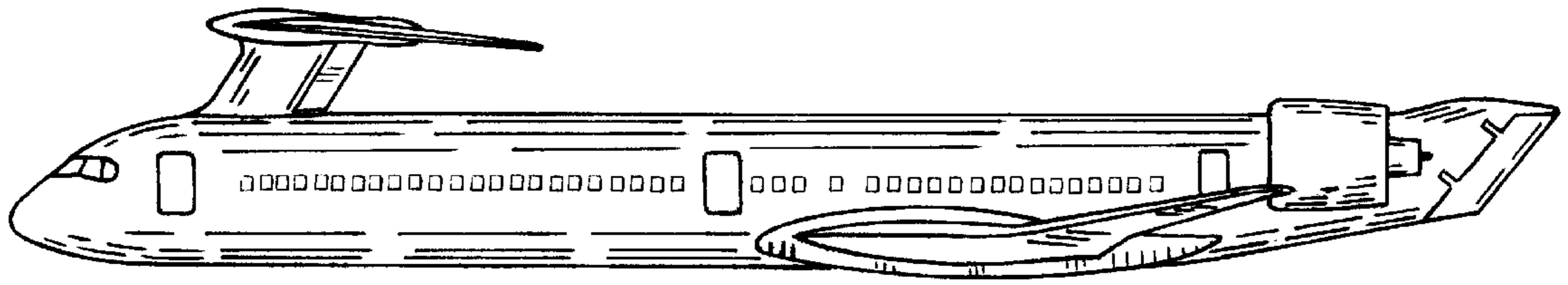

FIG. 6

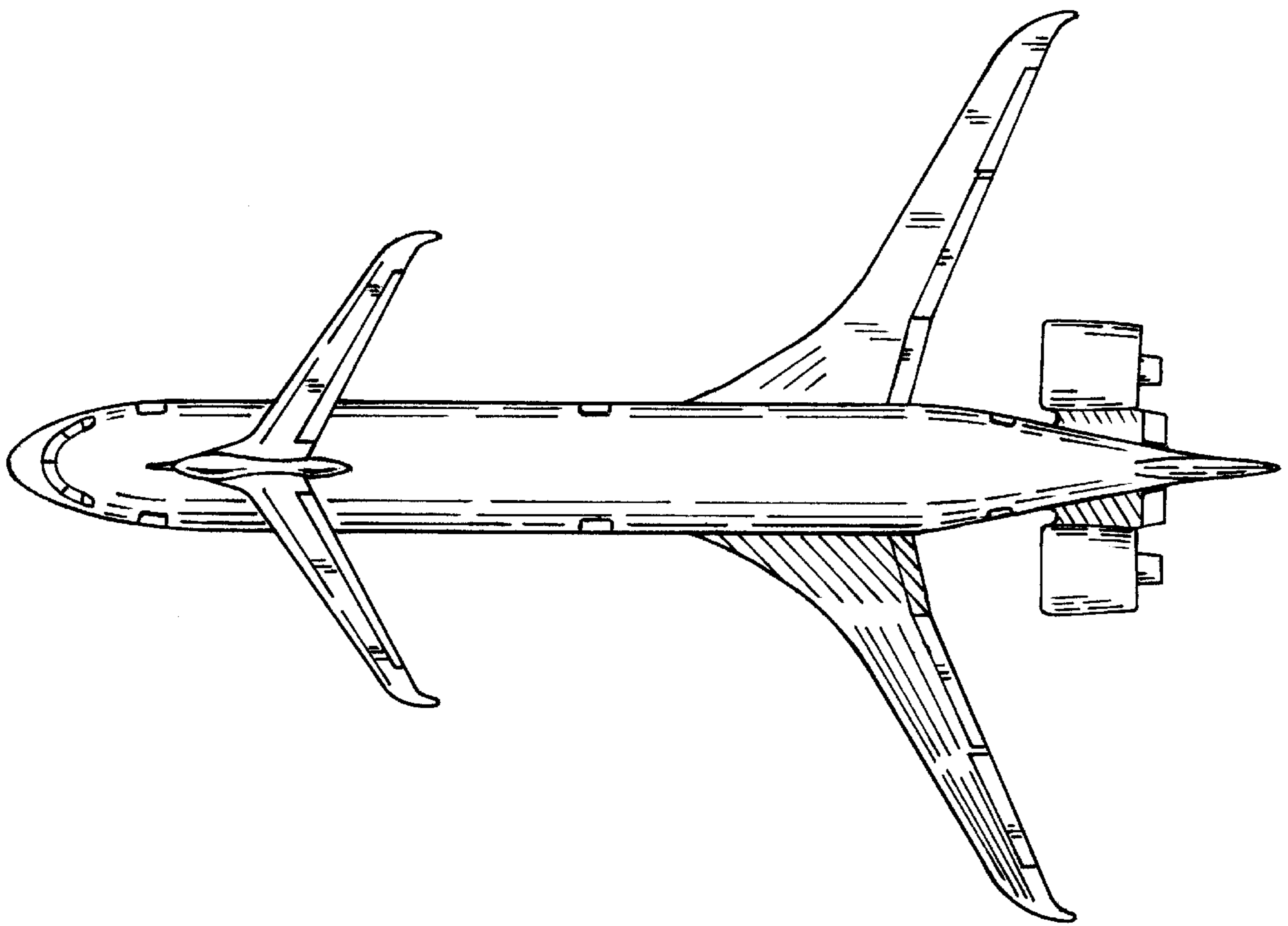

FIG. 7