



US00D451871B1

(12) **United States Design Patent**  
**Fujii et al.**

(10) **Patent No.:** **US D451,871 S**

(45) **Date of Patent:** **\*\* Dec. 11, 2001**

(54) **FRONT PORTION OF MOTOR VEHICLE**

(75) Inventors: **Takeshi Fujii; Tsuyoshi Toyoda;**  
**Hiroshi Takezawa**, all of Aki-gun (JP)

(73) Assignee: **Mazda Motor Corporation,**  
Hiroshima-ken (JP)

(\*\*) Term: **14 Years**

(21) Appl. No.: **29/136,215**

(22) Filed: **Jan. 29, 2001**

(30) **Foreign Application Priority Data**

Sep. 11, 2000 (JP) ..... 12-025296  
Sep. 11, 2000 (JP) ..... 12-025297

(51) **LOC (7) Cl.** ..... **12-16**

(52) **U.S. Cl.** ..... **D12/196**

(58) **Field of Search** ..... D12/196, 90-92;  
296/185

(56) **References Cited**

**U.S. PATENT DOCUMENTS**

D. 373,331 9/1996 Ohkura et al. ....  
D. 422,546 4/2000 Toyoda .....  
D. 422,547 \* 4/2000 Kitamura et al. .... D12/196  
D. 423,438 \* 4/2000 Shimazu ..... D12/196  
D. 432,065 \* 10/2000 Kitamura et al. .... D12/196  
D. 443,575 \* 7/2001 Okazaki et al. .... D12/196

**OTHER PUBLICATIONS**

Notice of Reasons for Rejection, Japanese Design Applica-  
tion No. 2000-025296, Mailing No. 018309, Mailing Date:  
Apr. 9, 2001, Partial Translation published Jun. 1, 1999.

CARGRAPHIC pp. 136, Jun. 1, 1999, vol. 38, No. 6.  
Notice of Reasons for Rejection, Japanese Design Applica-  
tion No. 2000-025297, Mailing No. 018297, Mailing Date:  
Apr. 9, 2001, Partial Translation published Jun. 1, 1999.

\* cited by examiner

*Primary Examiner*—Melody N. Brown

(74) *Attorney, Agent, or Firm*—Nixon Peabody LLP;  
Donald R. Studebaker

(57) **CLAIM**

The ornamental design for a front portion of motor vehicle,  
as shown and described.

**DESCRIPTION**

FIG. 1 is a perspective view of front portion of motor vehicle  
showing a first embodiment of our new design;  
FIG. 2 is a front view thereof;  
FIG. 3 is a rear view of the motor vehicle;  
FIG. 4 is a right side view of the front portion of motor  
vehicle;  
FIG. 5 is a left side view thereof;  
FIG. 6 is a top view thereof;  
FIG. 7 is a perspective view of front portion of motor vehicle  
showing a second embodiment of our new design;  
FIG. 8 is a front view of FIG. 7;  
FIG. 9 is a rear view of FIG. 7;  
FIG. 10 is a right side view of FIG. 7;  
FIG. 11 is a left side view of FIG. 7; and,  
FIG. 12 is a top view of FIG. 7.

The portion shown in broken lines is for illustrative purposes  
only and forms no part of the claimed design.

**1 Claim, 10 Drawing Sheets**

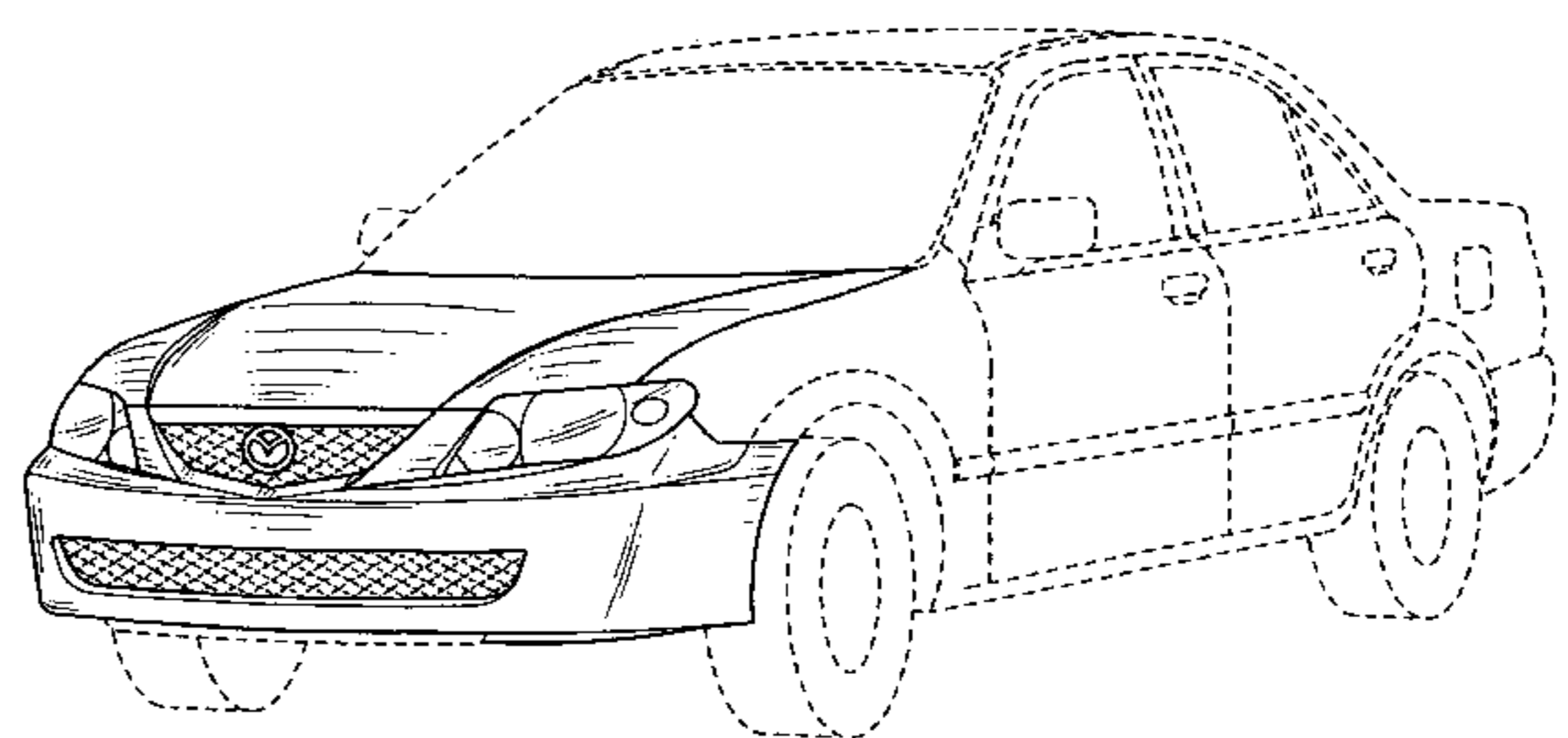
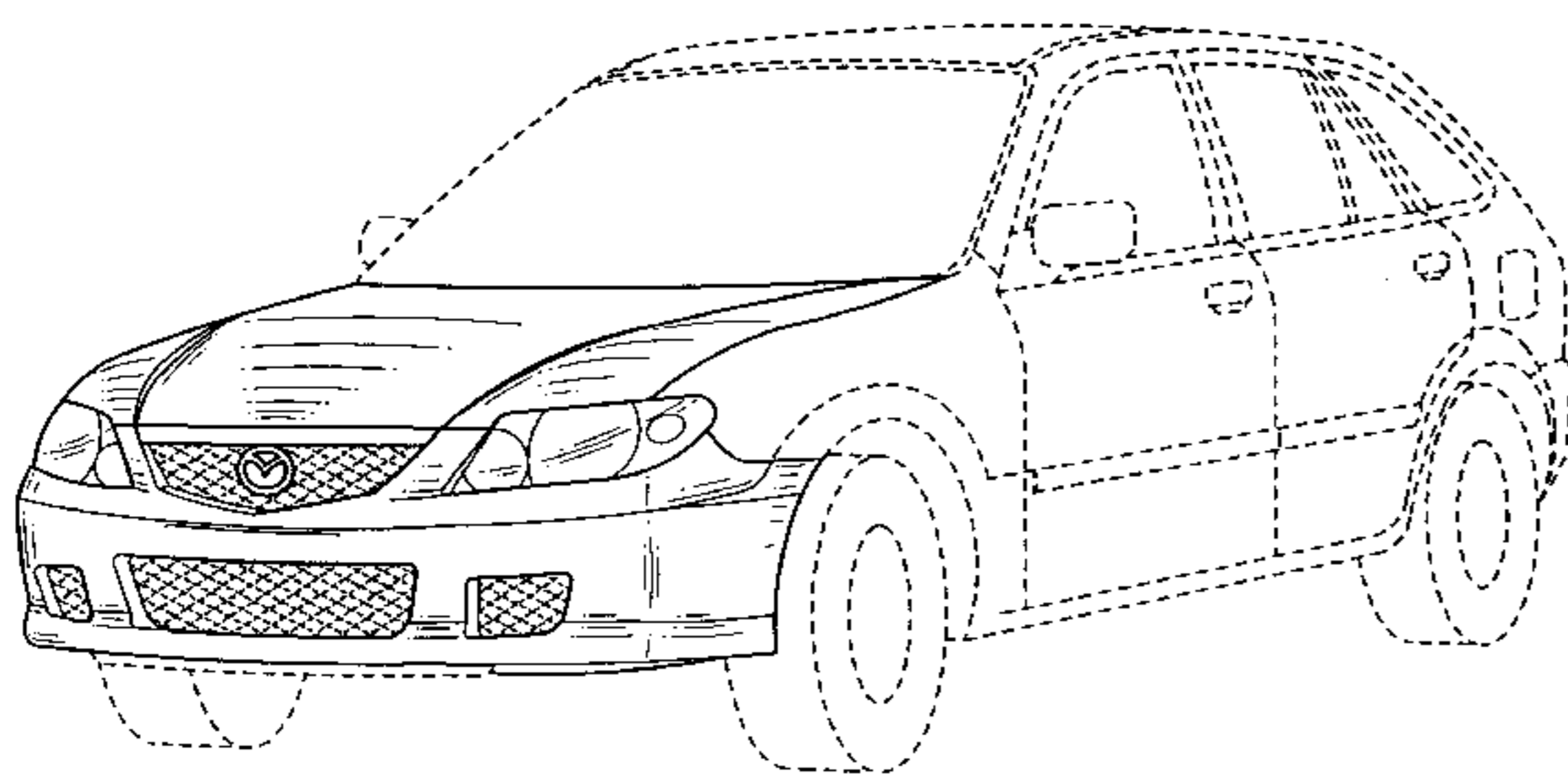

FIG. 1

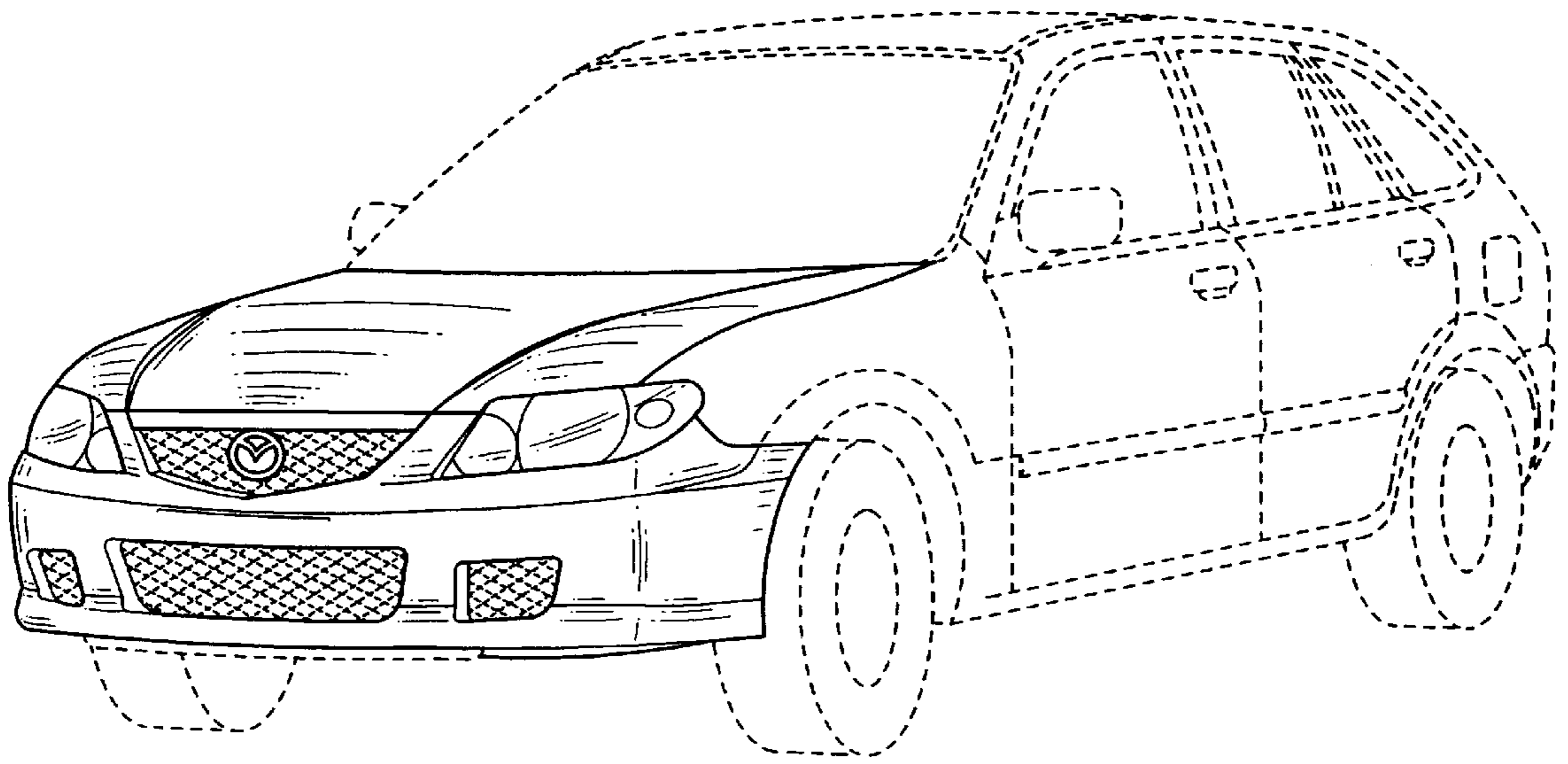

FIG. 2

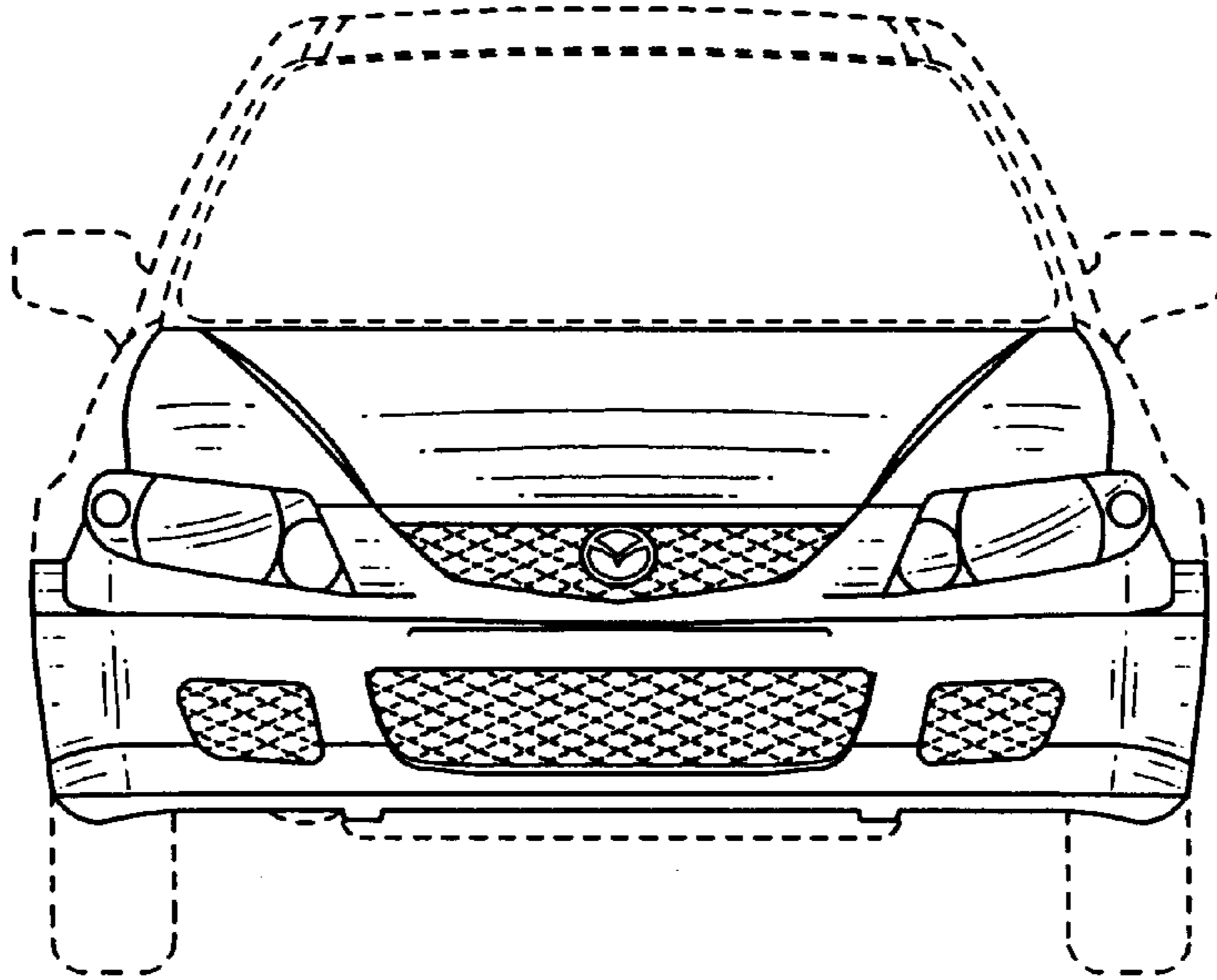

FIG. 3

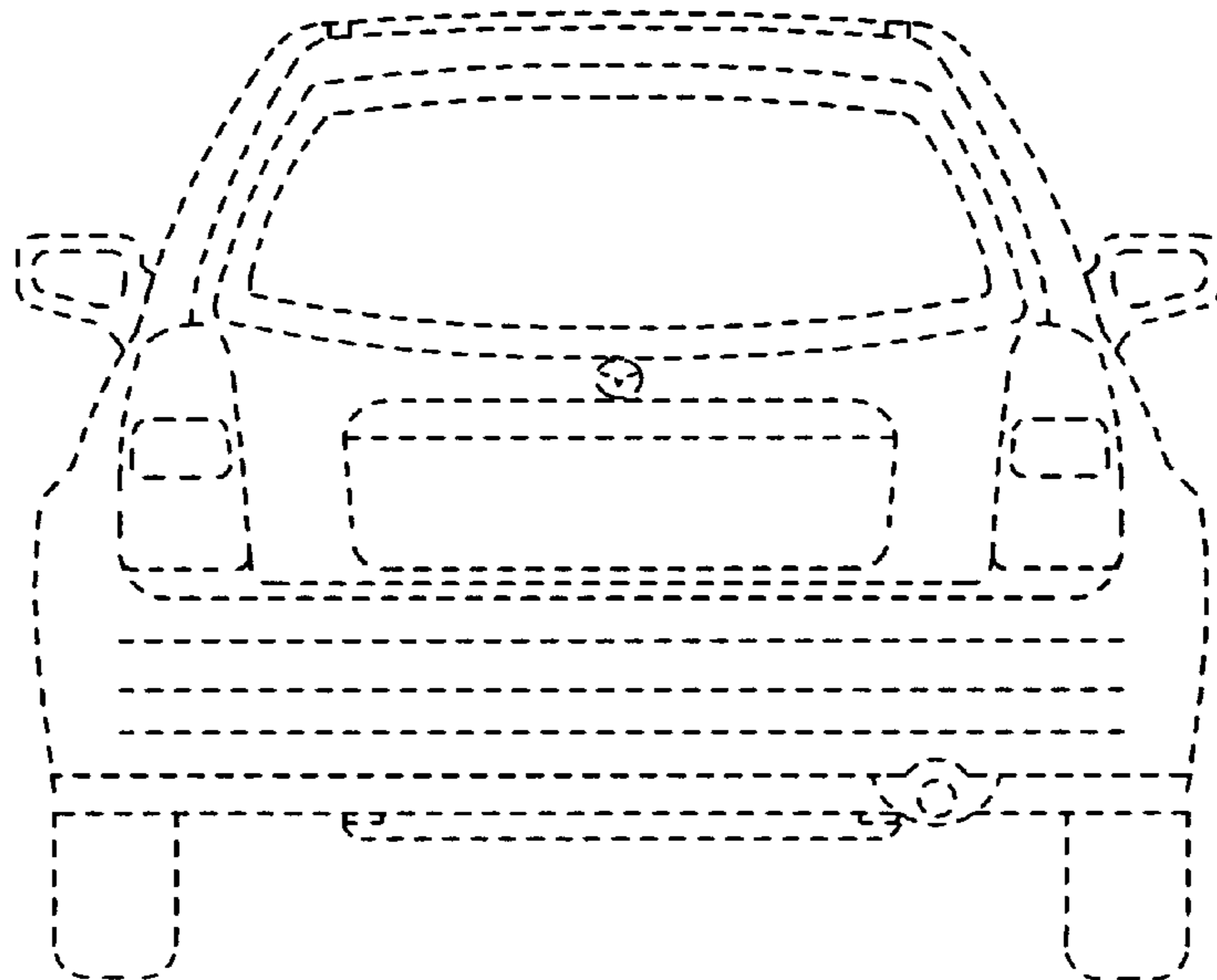

FIG. 4

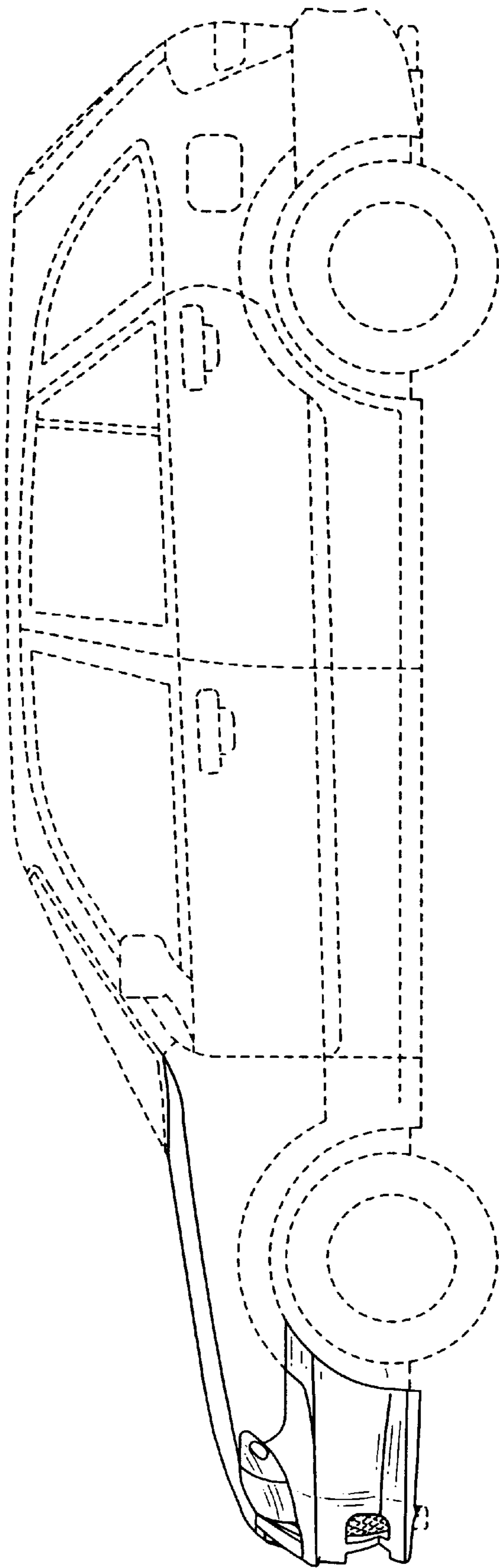

FIG. 5

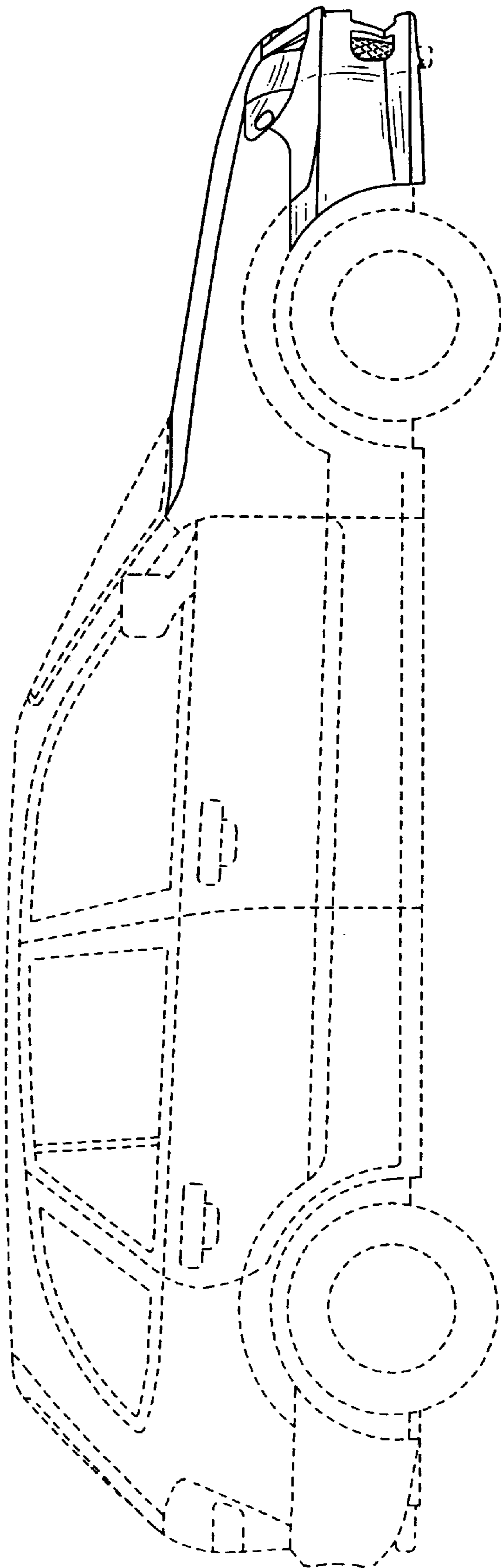

FIG. 6

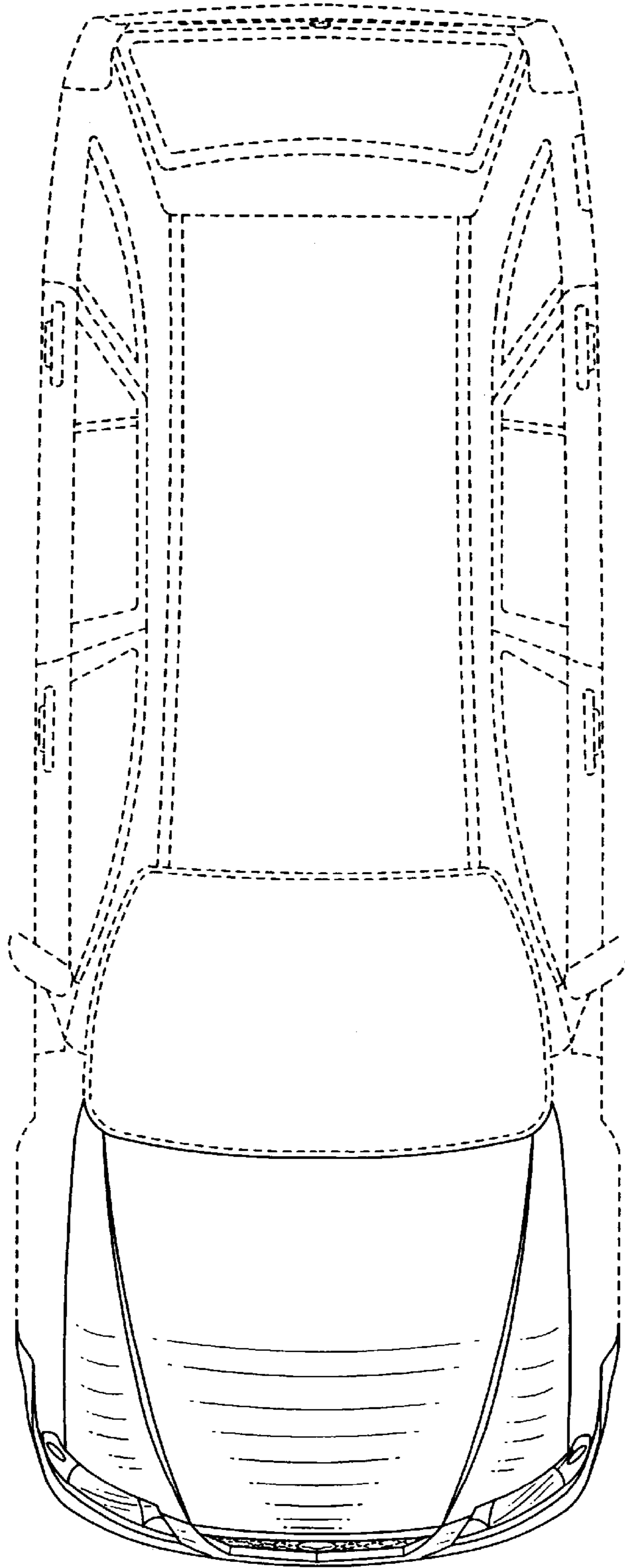

FIG. 7

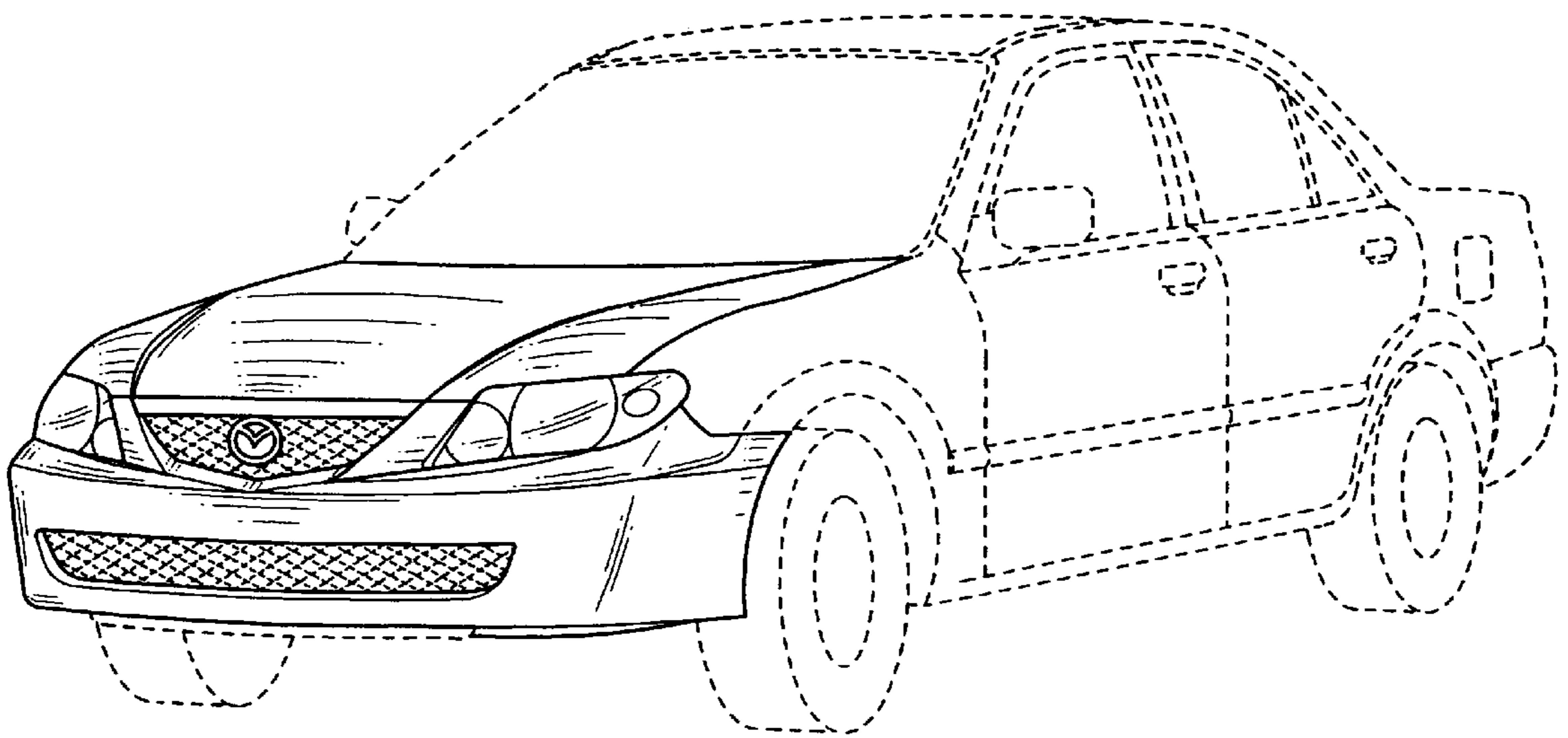

FIG. 8

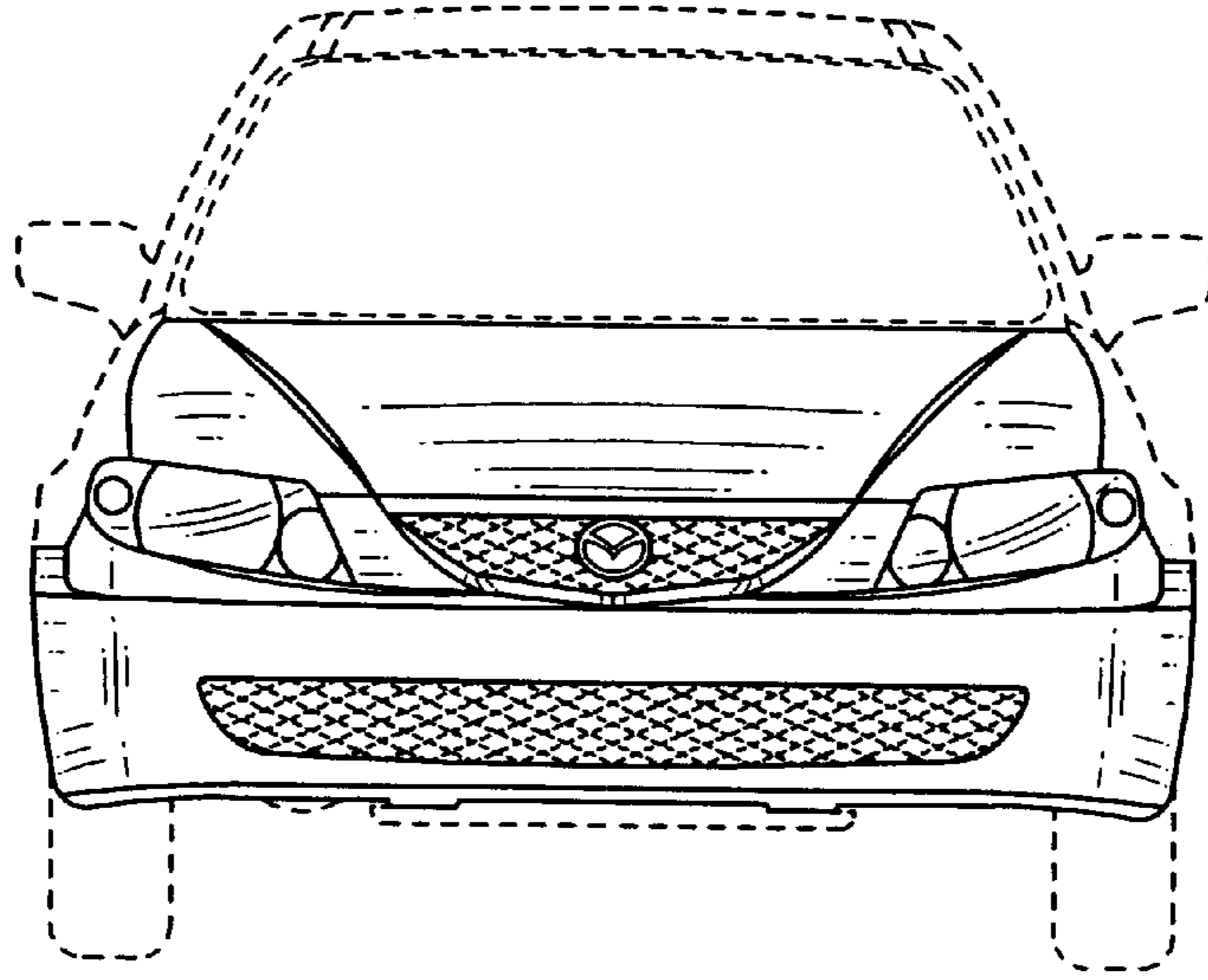

FIG. 9

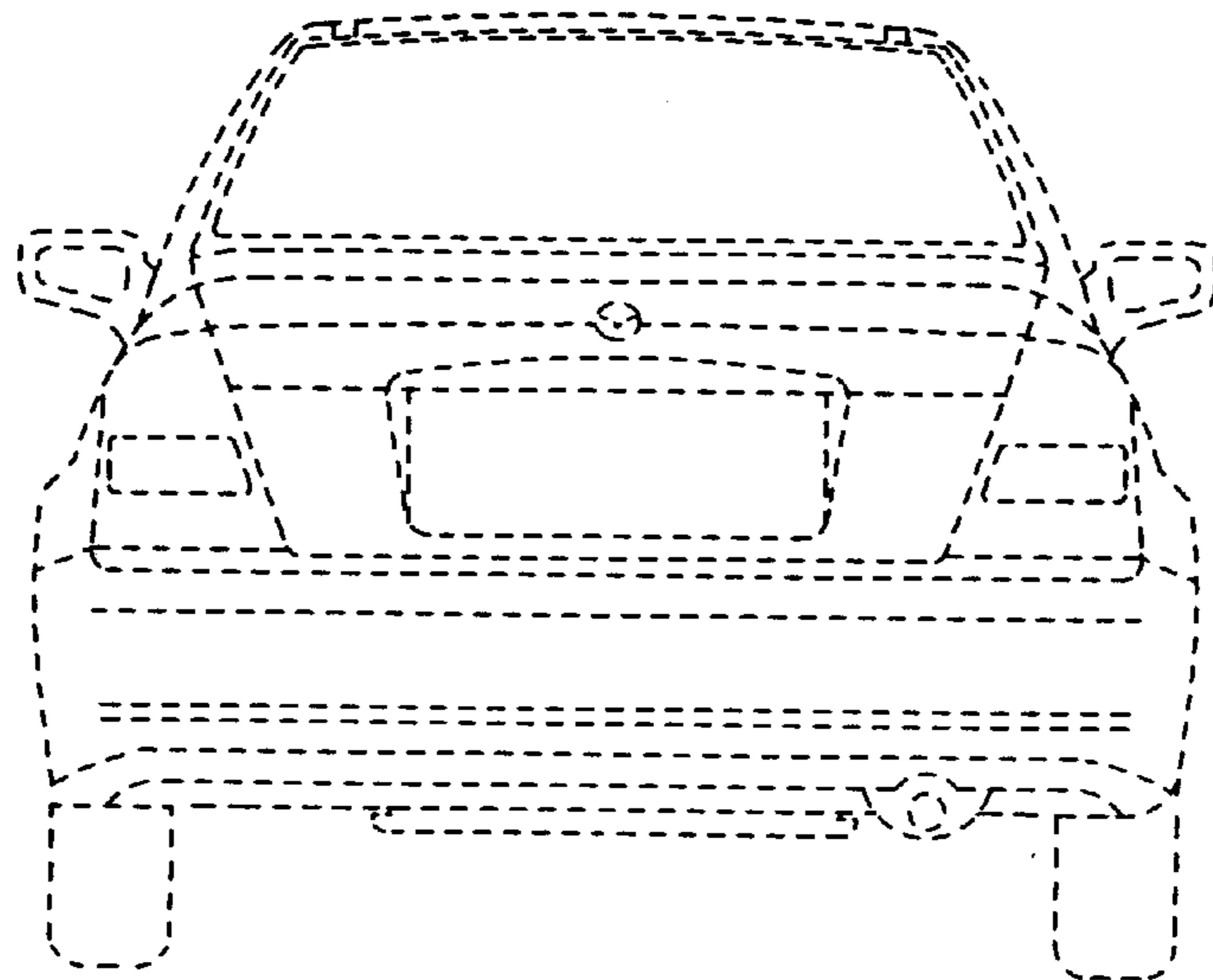



FIG. 10

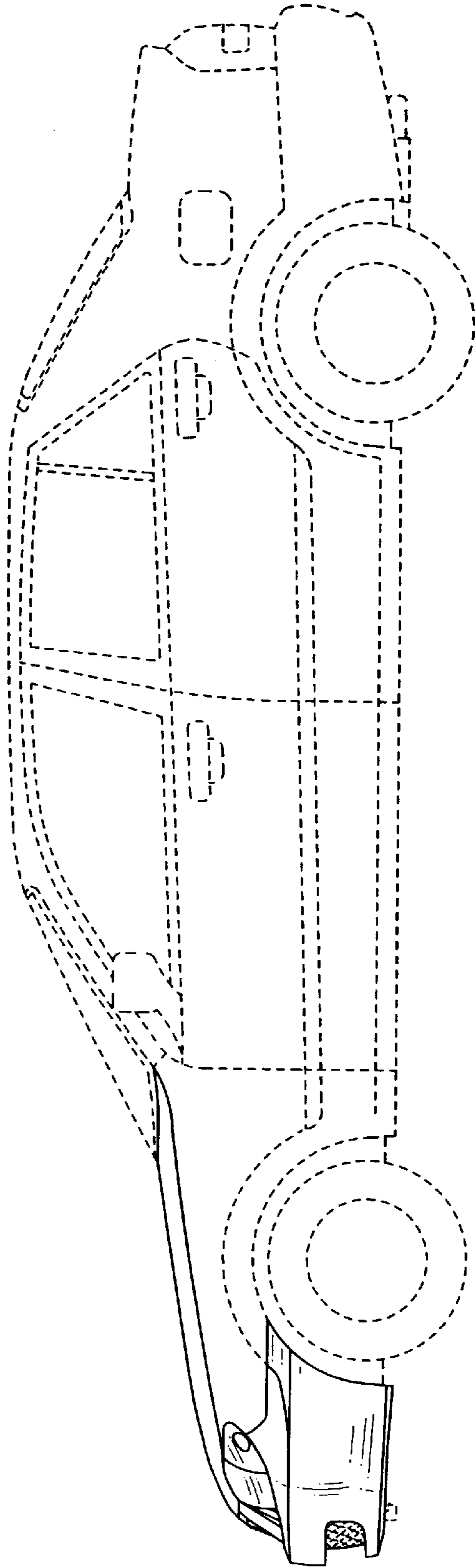

FIG. 11

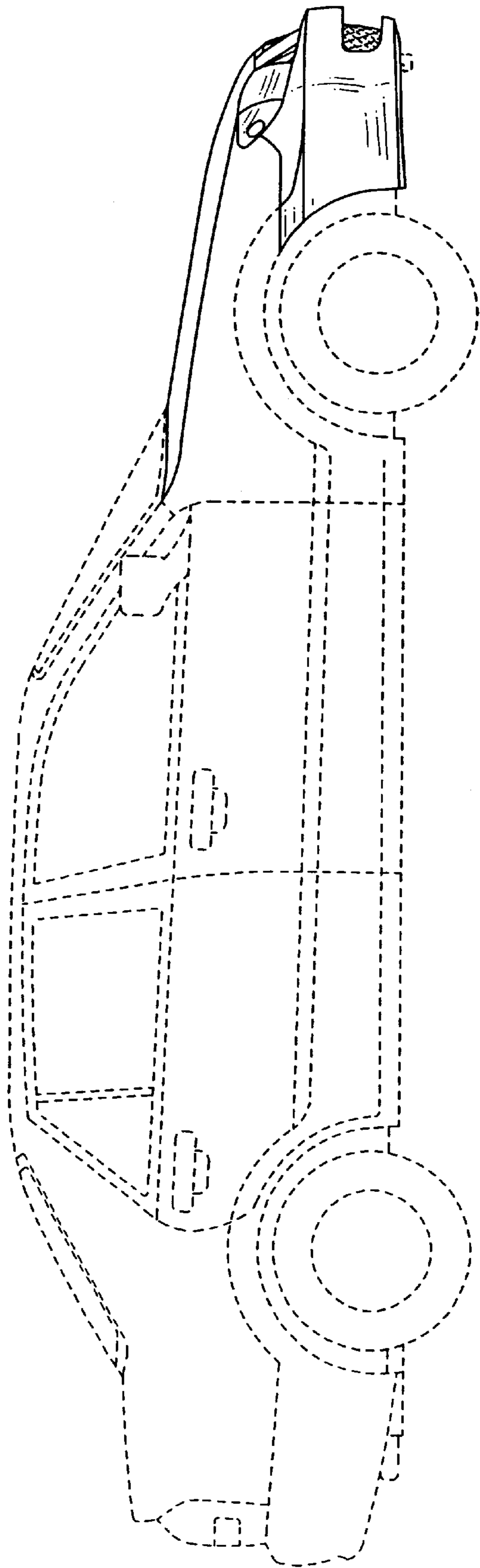

FIG. 12

