



US00D451466B1

(12) **United States Design Patent**  
**Fujii**

(10) **Patent No.:** **US D451,466 S**

(45) **Date of Patent:** **\*\* Dec. 4, 2001**

(54) **WHEEL FOR A MOTOR VEHICLE**

(75) **Inventor:** **Takeshi Fujii, Hatsukaichi (JP)**

(73) **Assignee:** **Mazda Motor Corporation,  
Hiroshima-ken (JP)**

(\*\*) **Term:** **14 Years**

(21) **Appl. No.:** **29/094,308**

(22) **Filed:** **Sep. 30, 1998**

(30) **Foreign Application Priority Data**

Mar. 31, 1998 (JP) ..... 10-9225

(51) **LOC (7) Cl.** ..... **12-16**

(52) **U.S. Cl.** ..... **D12/211**

(58) **Field of Search** ..... D12/204-211;  
301/37.1, 64.1, 65

(56) **References Cited**

**U.S. PATENT DOCUMENTS**

- D. 286,278 \* 10/1986 Sandberg ..... D12/211
- D. 370,883 \* 6/1996 Bhambra ..... D12/209
- D. 375,074 \* 10/1996 Sacco et al. .... D12/209
- D. 392,237 \* 3/1998 Kelley ..... D12/209
- D. 395,863 \* 7/1998 Saaco et al. .... D12/211
- D. 403,648 \* 1/1999 Feriero ..... D12/209
- D. 412,149 \* 7/1999 Corioni ..... D12/211

- D. 423,446 \* 4/2000 Chung ..... D12/211
- D. 428,377 \* 7/2000 Kubosaki et al. .... D12/209
- D. 428,845 \* 8/2000 Yoshida et al. .... D12/211
- D. 432,479 \* 10/2000 Lee et al. .... D12/209
- D. 433,371 \* 11/2000 Donikoglu ..... D12/209
- D. 436,568 \* 1/2001 Chung ..... D12/209
- D. 436,907 \* 1/2001 Ong ..... D12/209
- D. 436,912 \* 1/2001 Boyer ..... D12/211

\* cited by examiner

*Primary Examiner*—Stacia Cadmus

(74) *Attorney, Agent, or Firm*—Sidley Austin Brown & Wood; Hugh A. Abrams

(57) **CLAIM**

The ornamental design for a wheel for a motor vehicle, as shown and described.

**DESCRIPTION**

FIG. 1 is a perspective view of a wheel for a motor vehicle; FIG. 2 is a rear perspective view of the tire wheel; FIG. 3 is a front view of the tire wheel; FIG. 4 is a rear view of the tire wheel; FIG. 5 is a left side view of the tire wheel; FIG. 6 is a right side view of the tire wheel; FIG. 7 is a top view of the tire wheel; and, FIG. 8 is a bottom view of the tire wheel.

**1 Claim, 4 Drawing Sheets**





Fig. 1

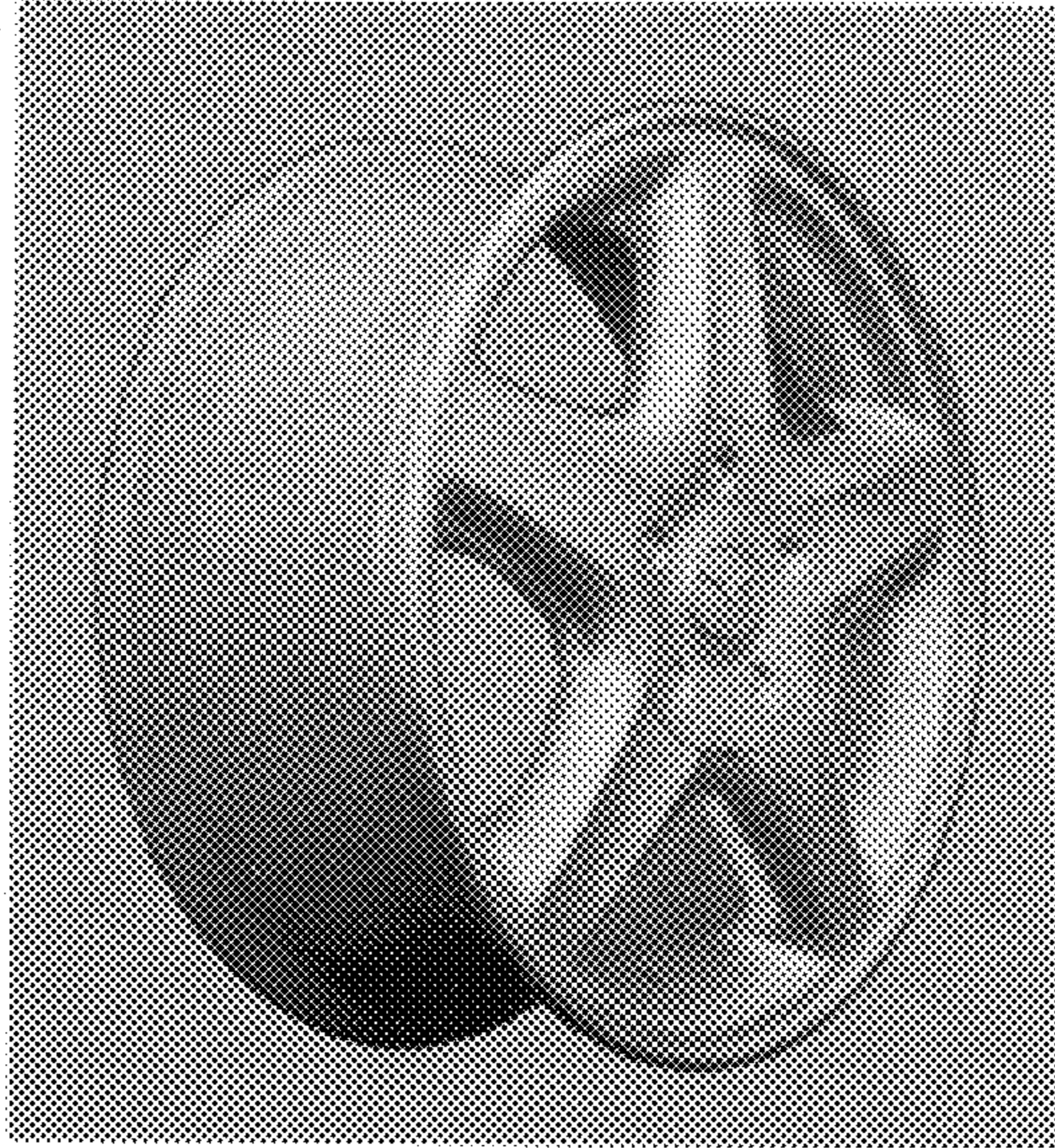

Fig. 2

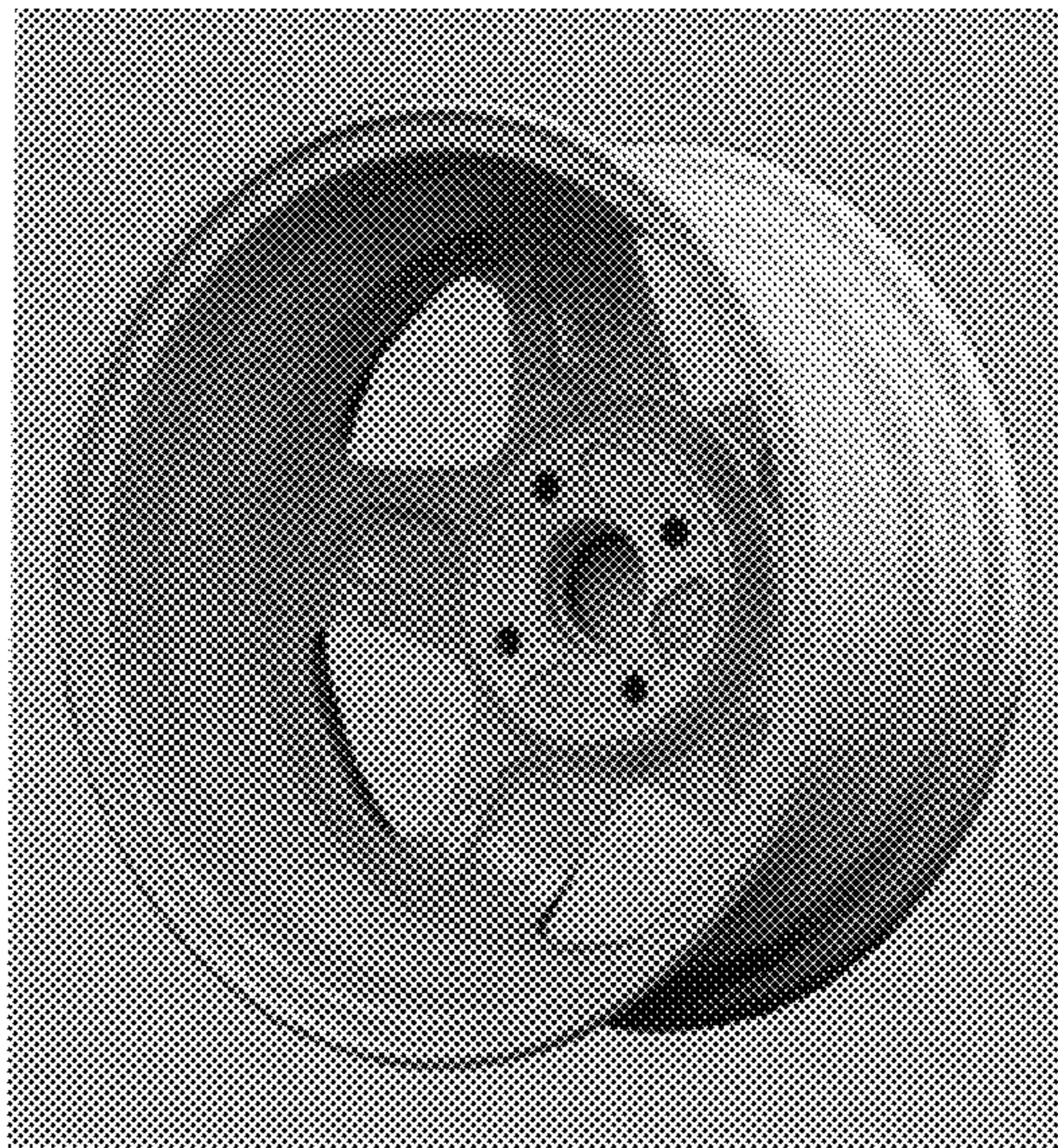



Fig. 3

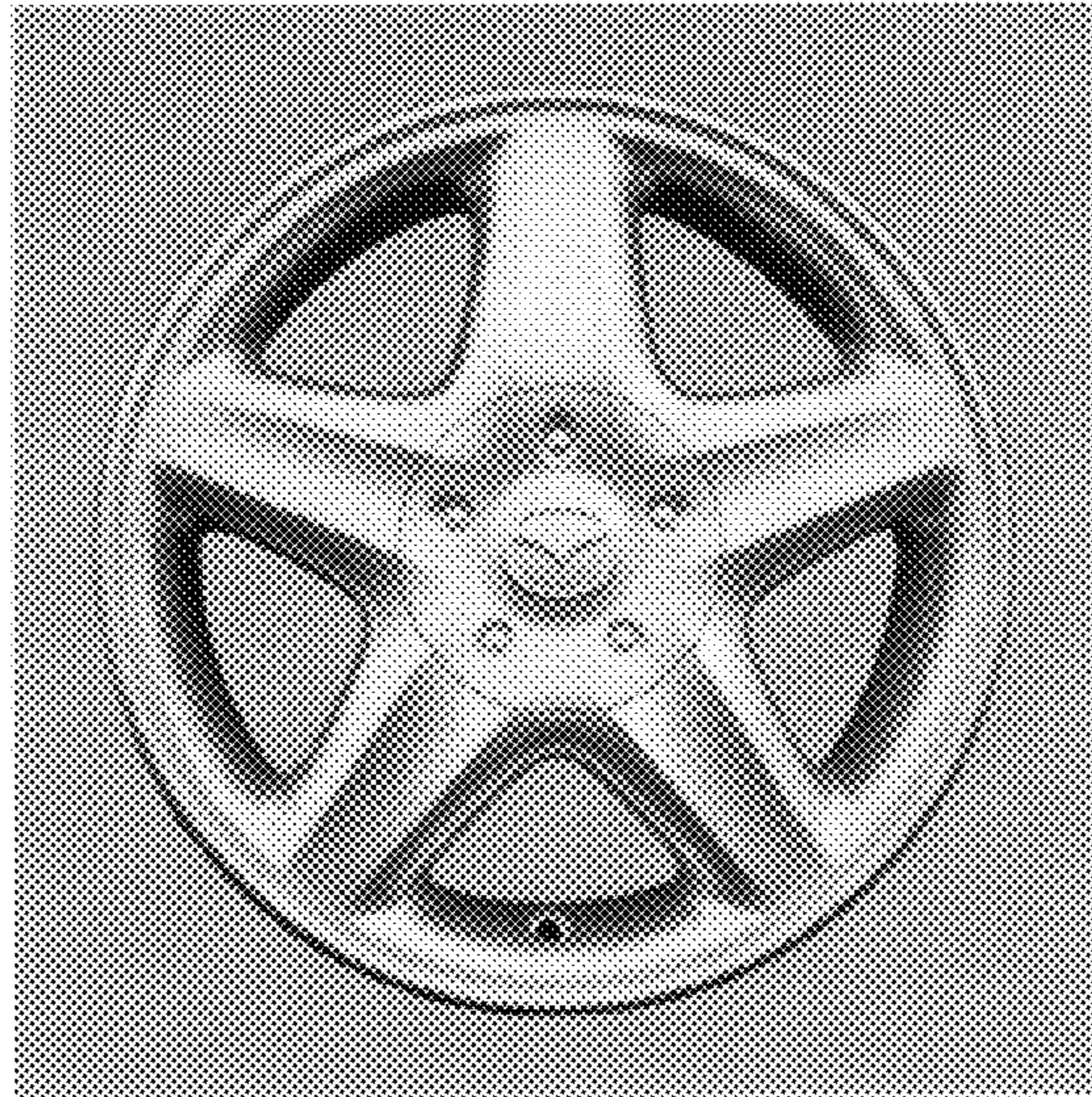

Fig. 4

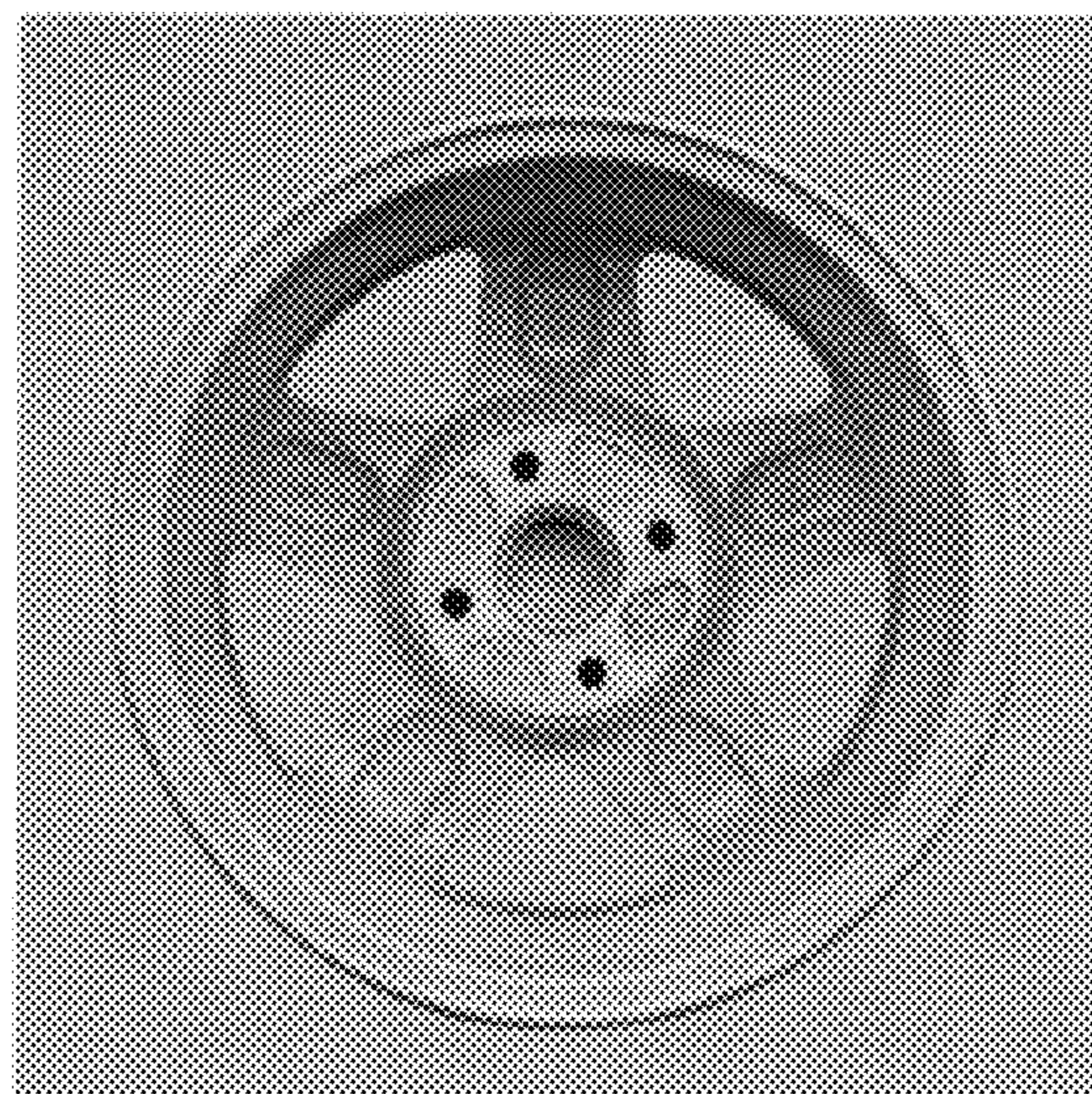



Fig. 5

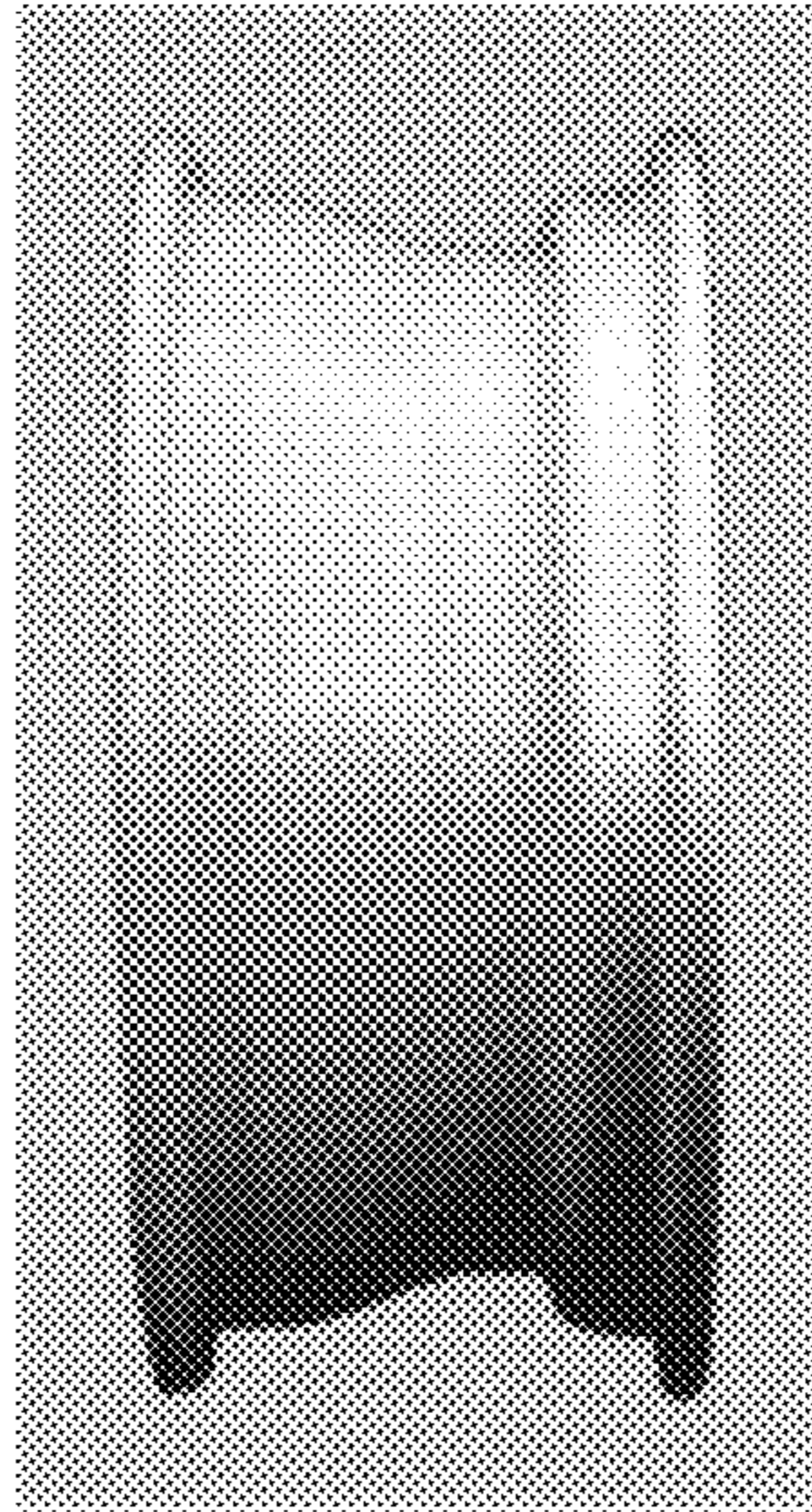

Fig. 6

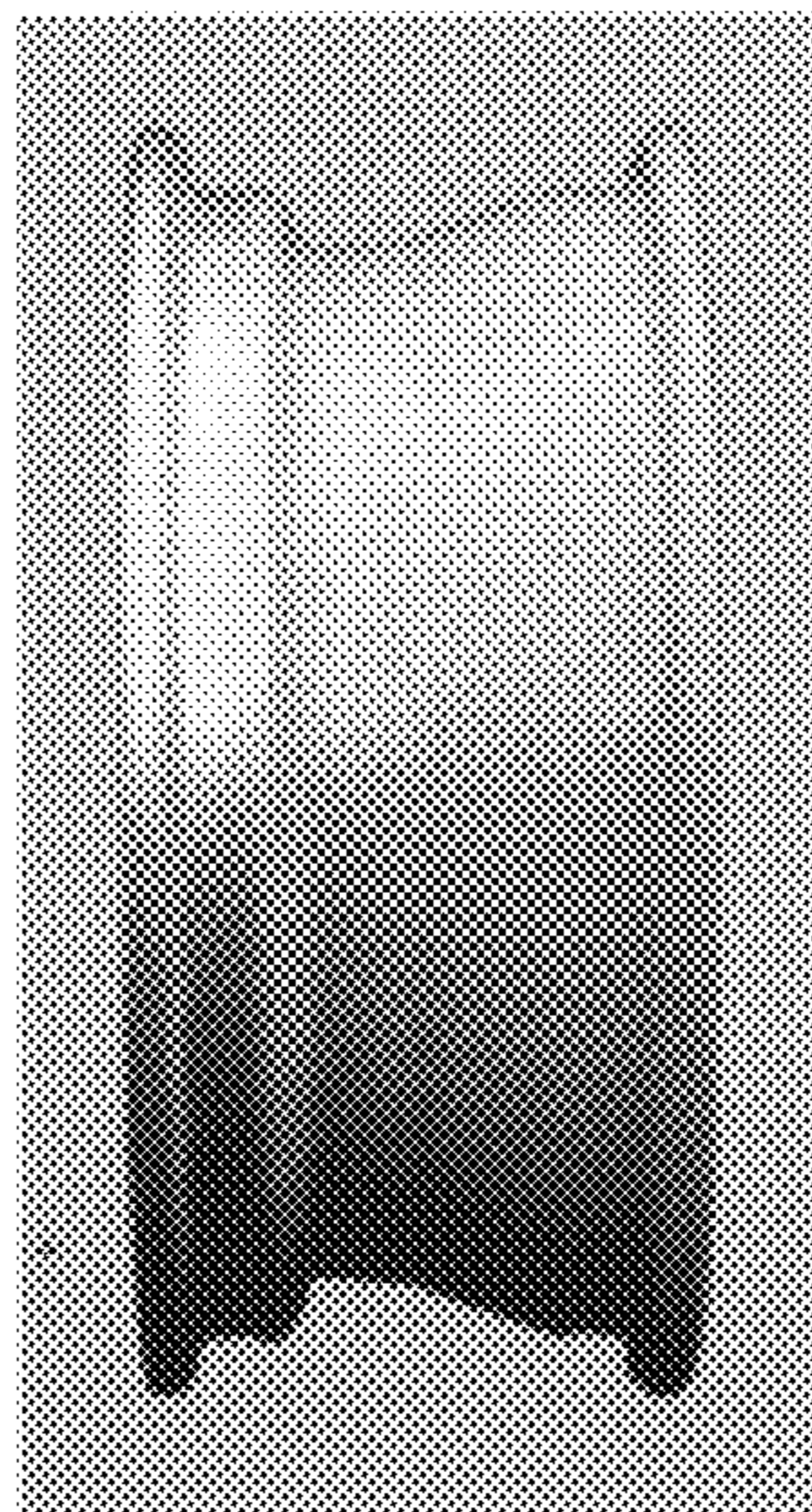

Fig. 7

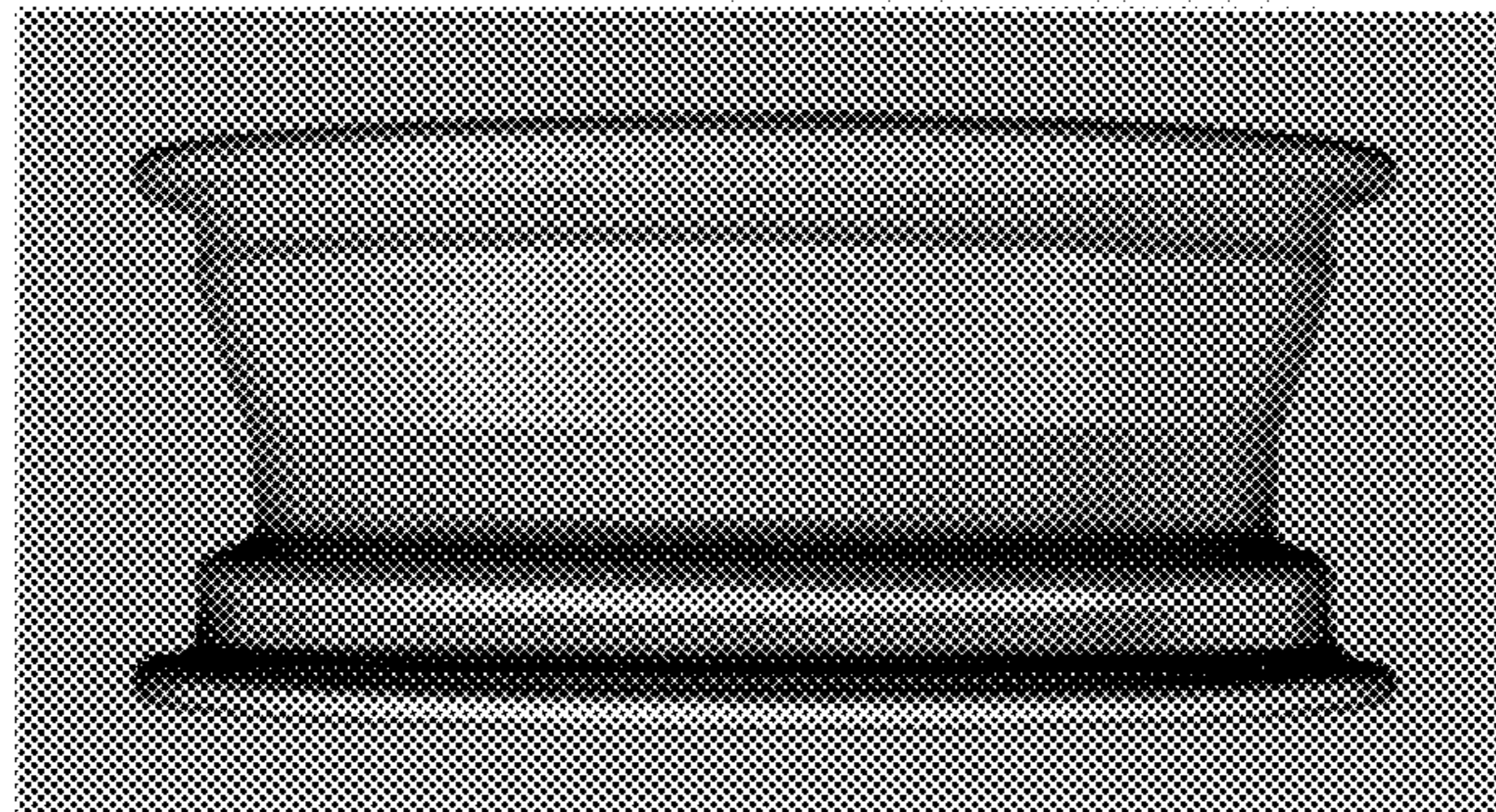

Fig. 8

