



US00D451375B1

(12) **United States Design Patent**  
**Shinjo et al.**

(10) **Patent No.:** **US D451,375 S**

(45) **Date of Patent:** **\*\* \*Dec. 4, 2001**

(54) **CLINCH NUT**

(75) Inventors: **Katsumi Shinjo**, Osaka; **Tadashi Shinjo**, Sakai; **Hiroshi Shinjo**, Osaka, all of (JP)

(73) Assignee: **Yugenkaisha Shinjo Seisakusho**, Osaka (JP)

(\*) Notice: This patent is subject to a terminal disclaimer.

(\*\*) Term: **14 Years**

(21) Appl. No.: **29/131,927**

(22) Filed: **Oct. 31, 2000**

(30) **Foreign Application Priority Data**

May 11, 2000 (JP) ..... 12-012359

(51) **LOC (7) Cl.** ..... **08-08**

(52) **U.S. Cl.** ..... **D8/397**

(58) **Field of Search** ..... D8/397, 399; 411/172, 411/174, 175, 179, 184, 427, 432, 533, 978, 190, 910, 330, 326, 205, 222, 429

(56) **References Cited**

**U.S. PATENT DOCUMENTS**

D. 223,747 \* 6/1972 Shinjo ..... D8/397  
3,736,969 \* 6/1973 Wörn et al. .

**OTHER PUBLICATIONS**

Machine Design—The Fasteners Book; p. 118; Quintlock-nut, Sep. 29, 1960.\*

Machine Design—The Fasteners Book; p. 139; Self-clinching floating nut, Sep. 29, 1960.\*

Machine Design—The Fasteners Book; p. 133; Shakeproof Locknut, Sep. 29, 1960.\*

\* cited by examiner

*Primary Examiner*—B. J. Bullock

(74) *Attorney, Agent, or Firm*—Antonelli, Terry, Stout & Kraus, LLP

(57) **CLAIM**

The ornamental design for a clinch nut, as shown and described.

**DESCRIPTION**

In the drawings, each Figure thereof being of a clinch nut. FIG. 1 is a top plan view; FIG. 2 is a front elevation; FIG. 3 is a bottom plan view; FIG. 4 is a right-side elevation; FIG. 5 is a cross section taken along the line 5—5 in FIG. 1; FIG. 6 is a downwards perspective view; and, FIG. 7 is an upwards perspective view.

**1 Claim, 3 Drawing Sheets**

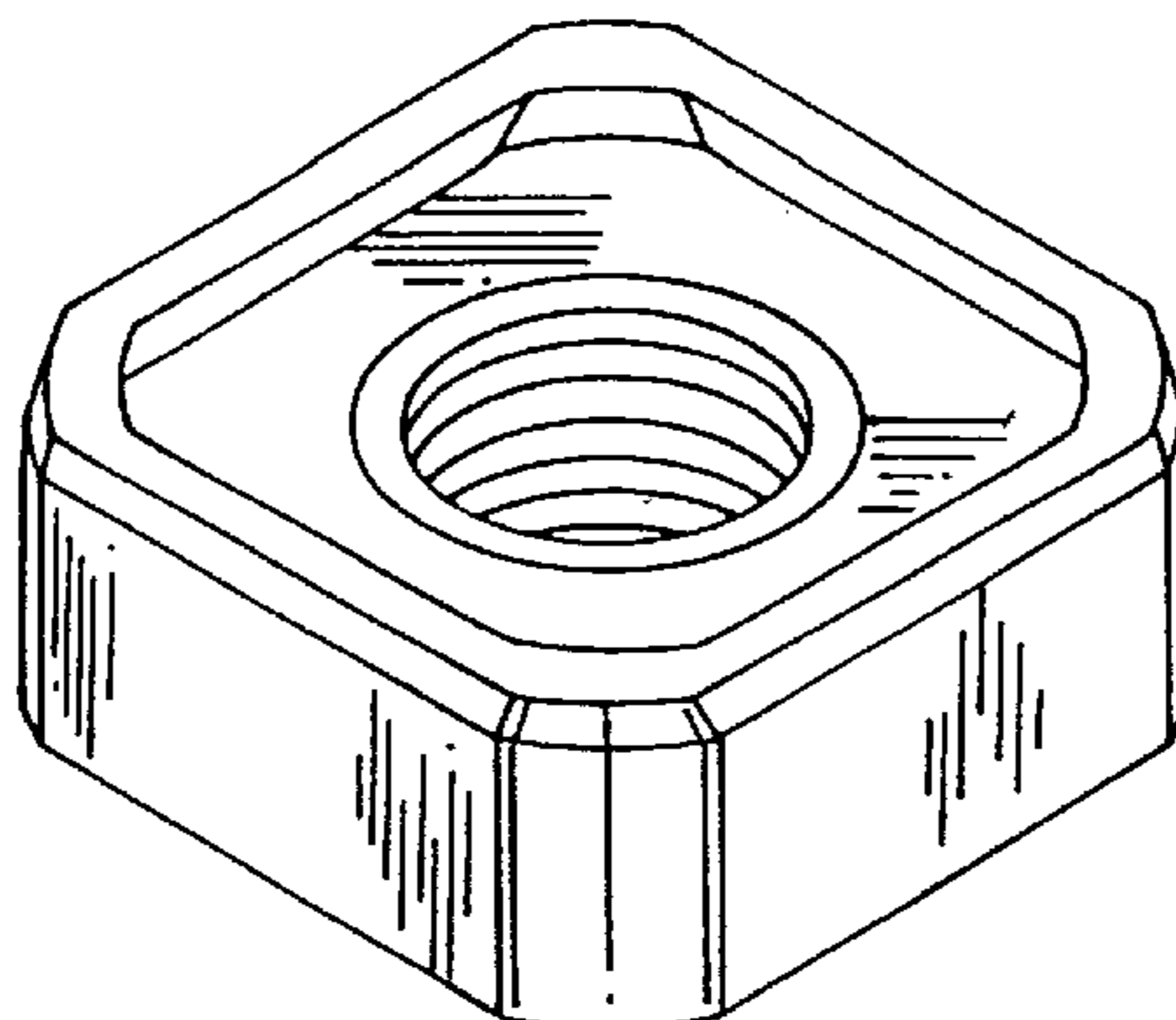
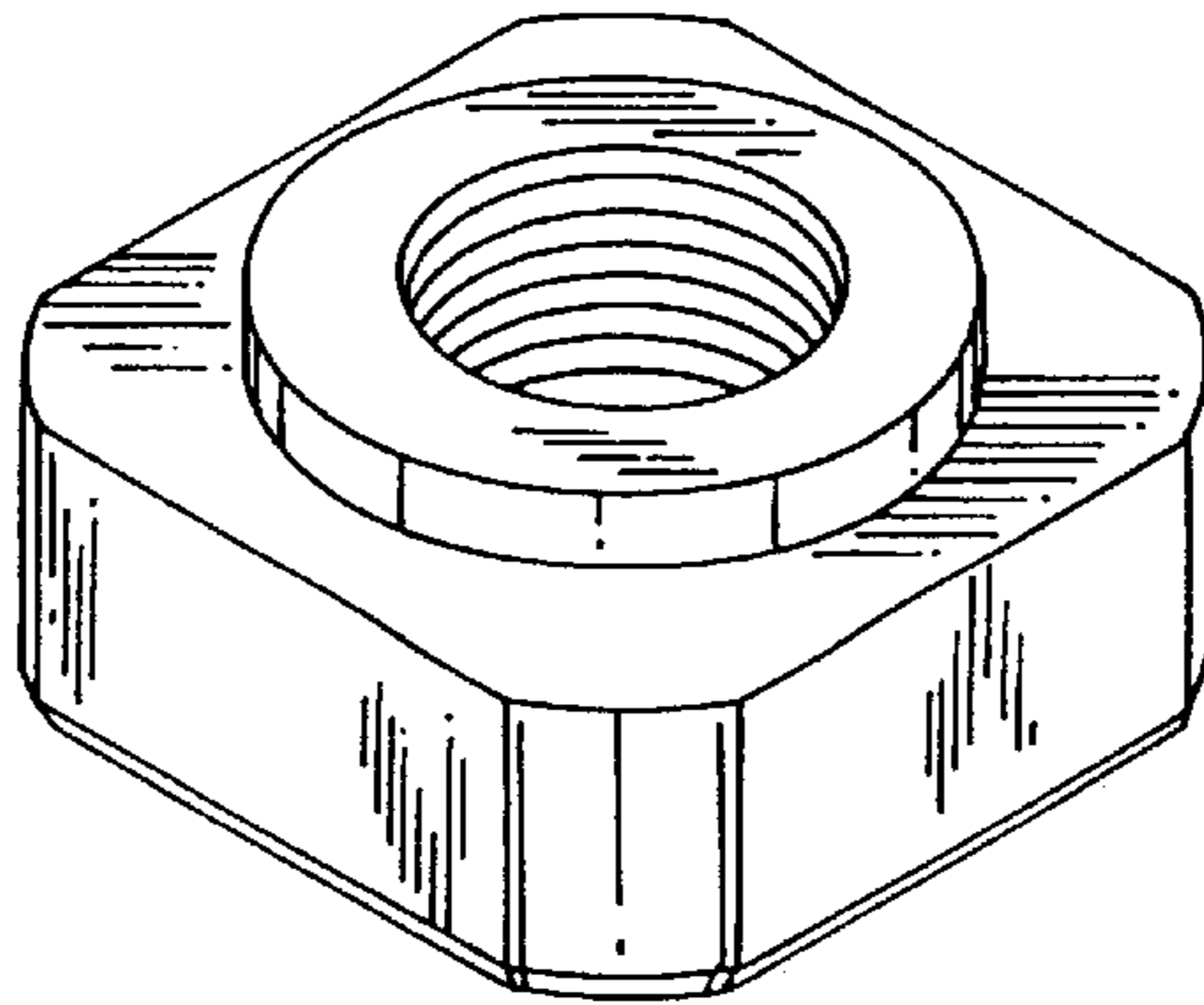

**FIG. 1**

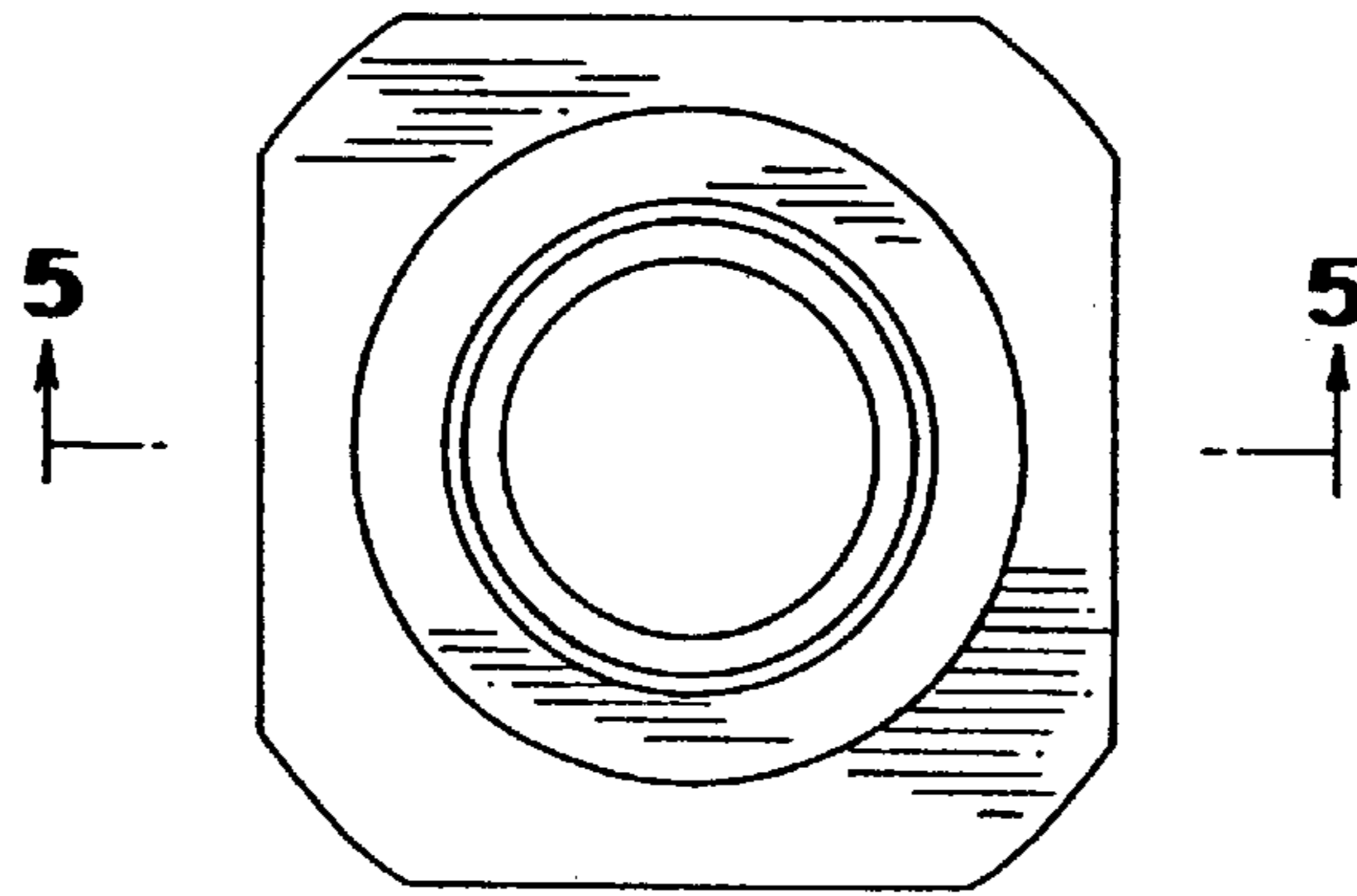

**FIG. 2**

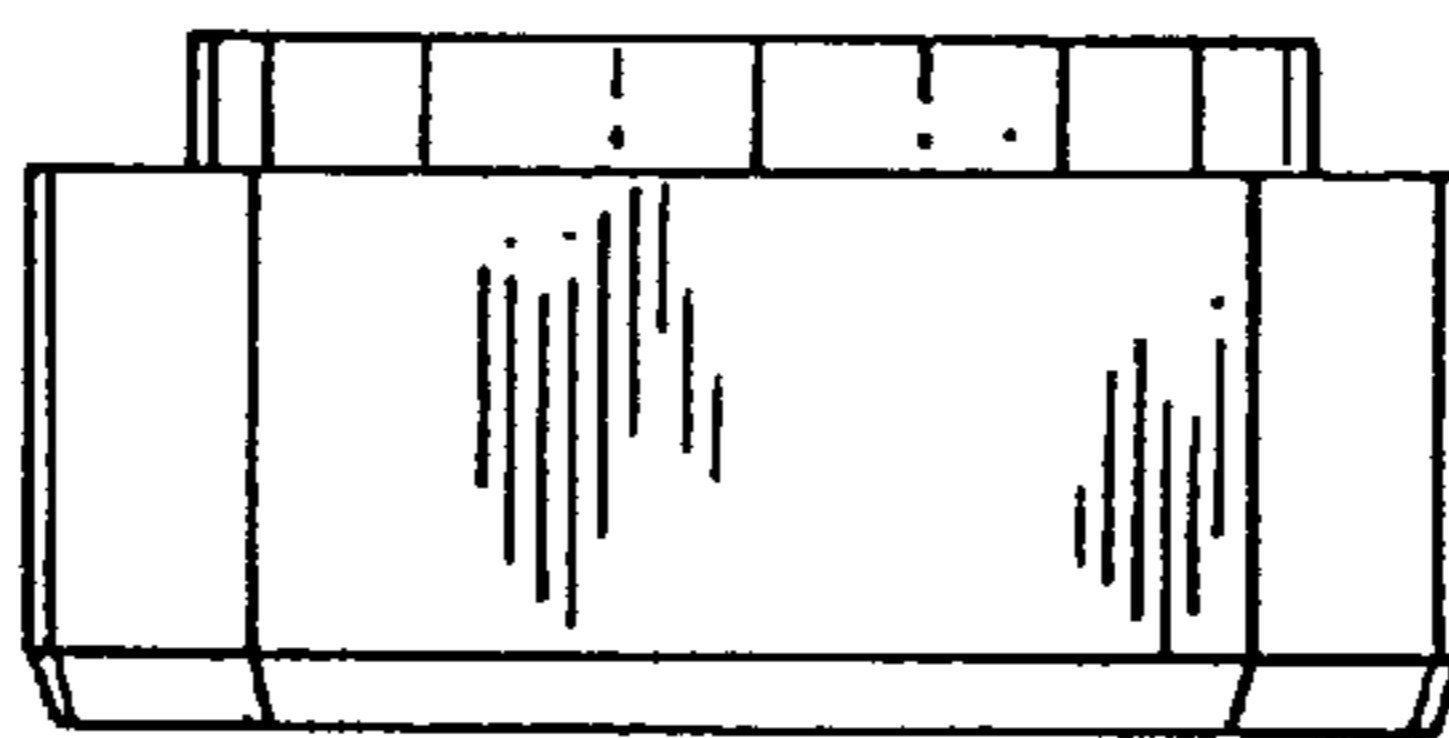

**FIG. 3**

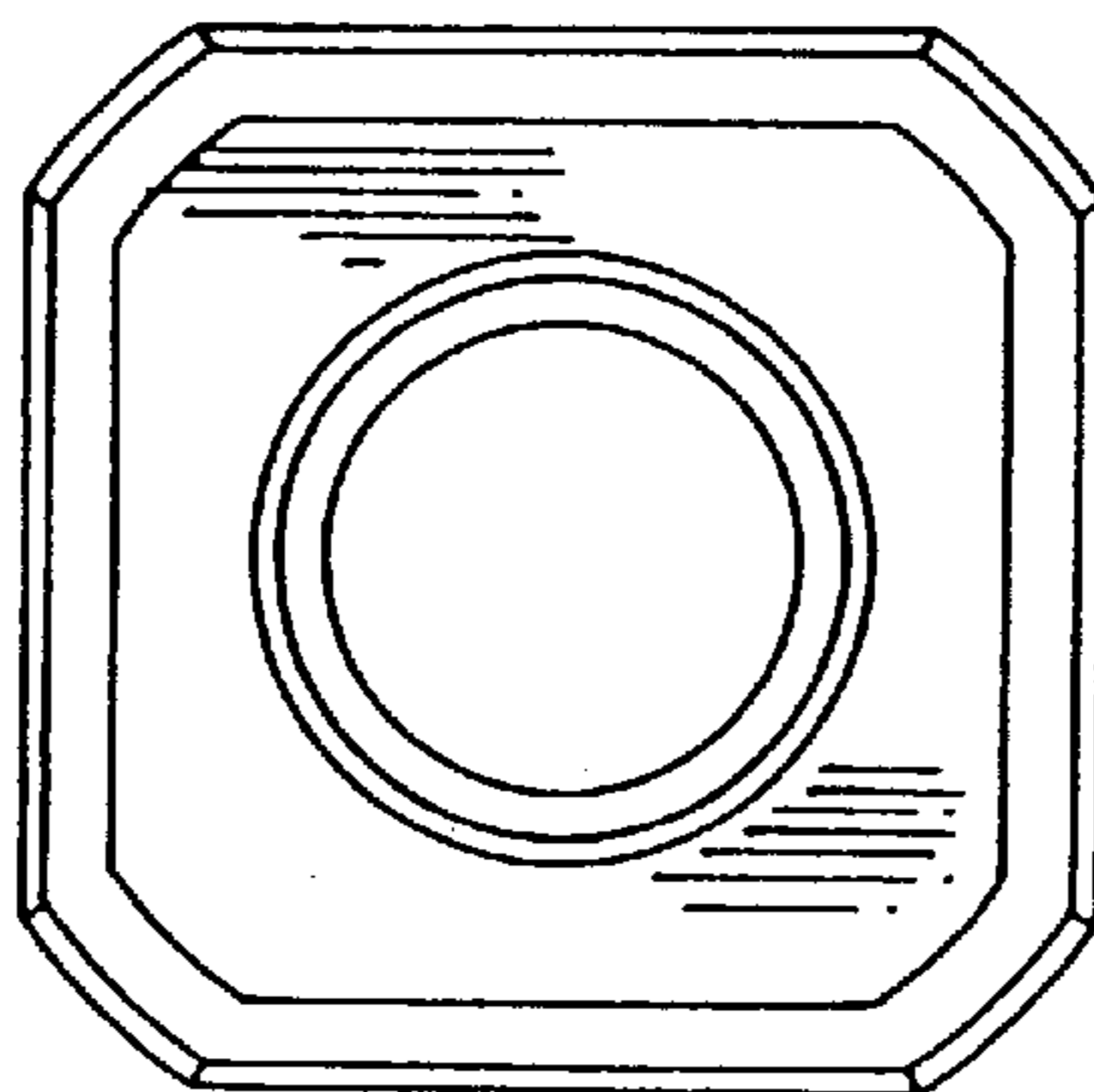

**FIG. 4**

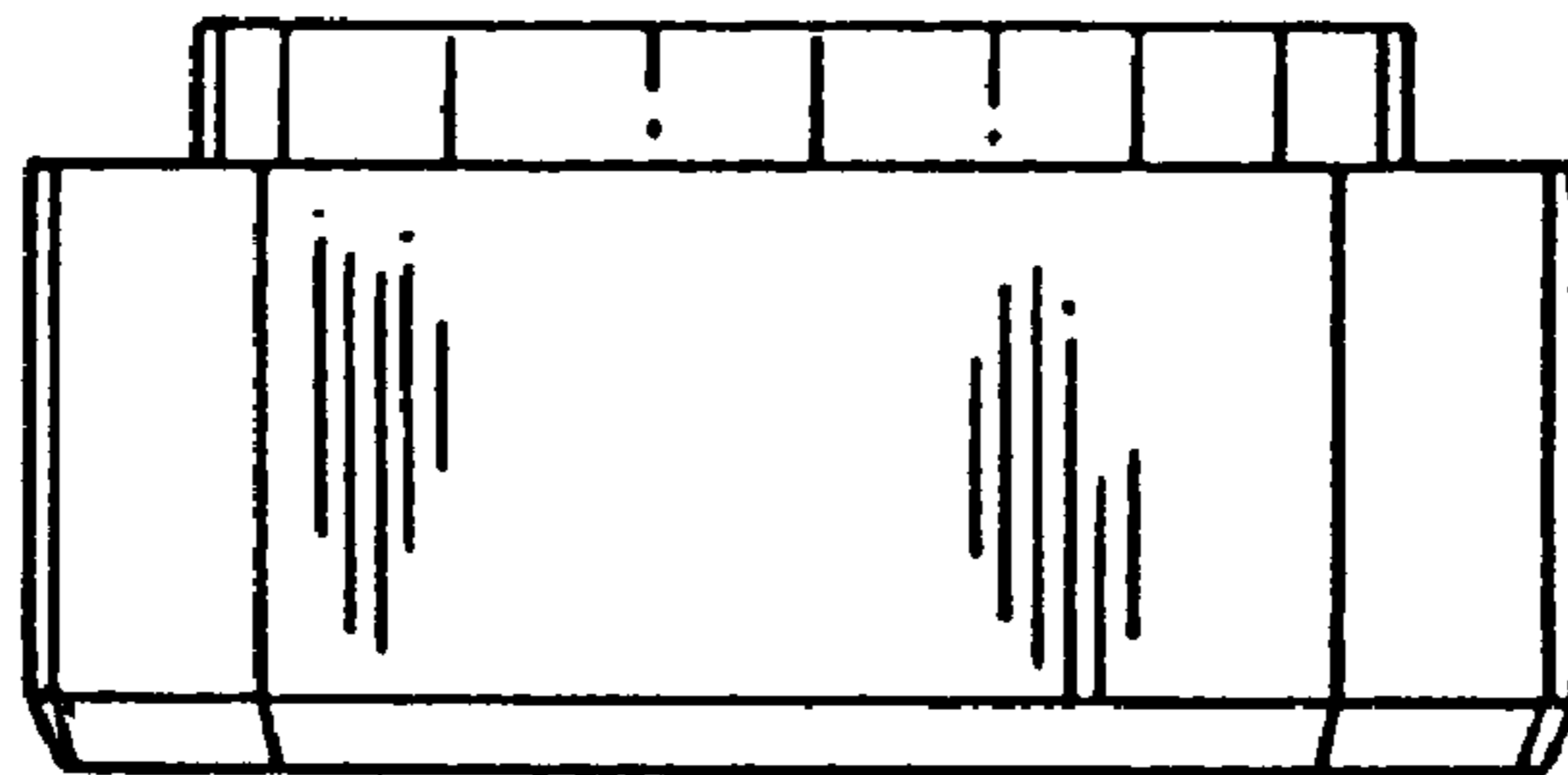

**FIG. 5**

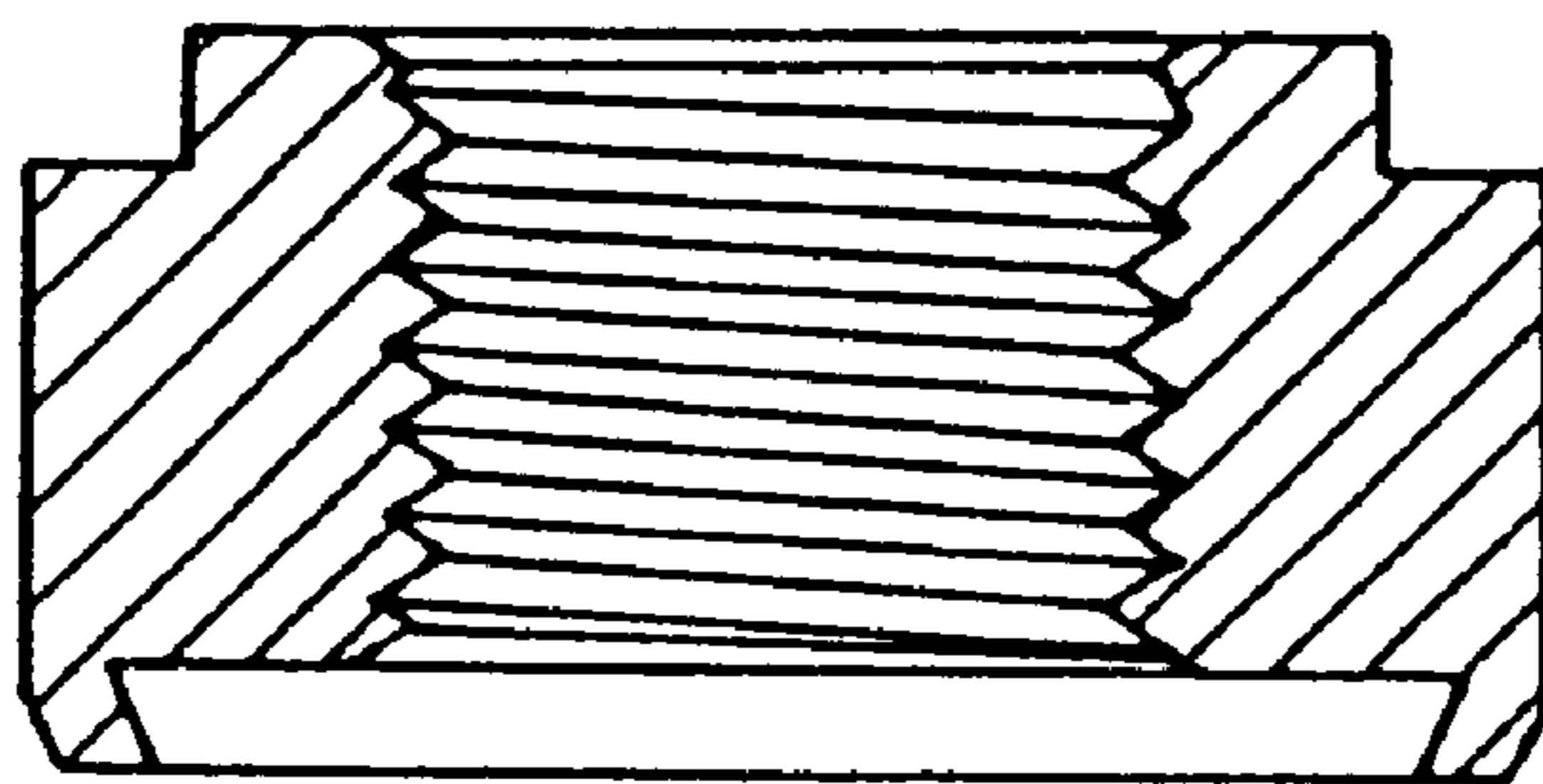

**FIG. 6**

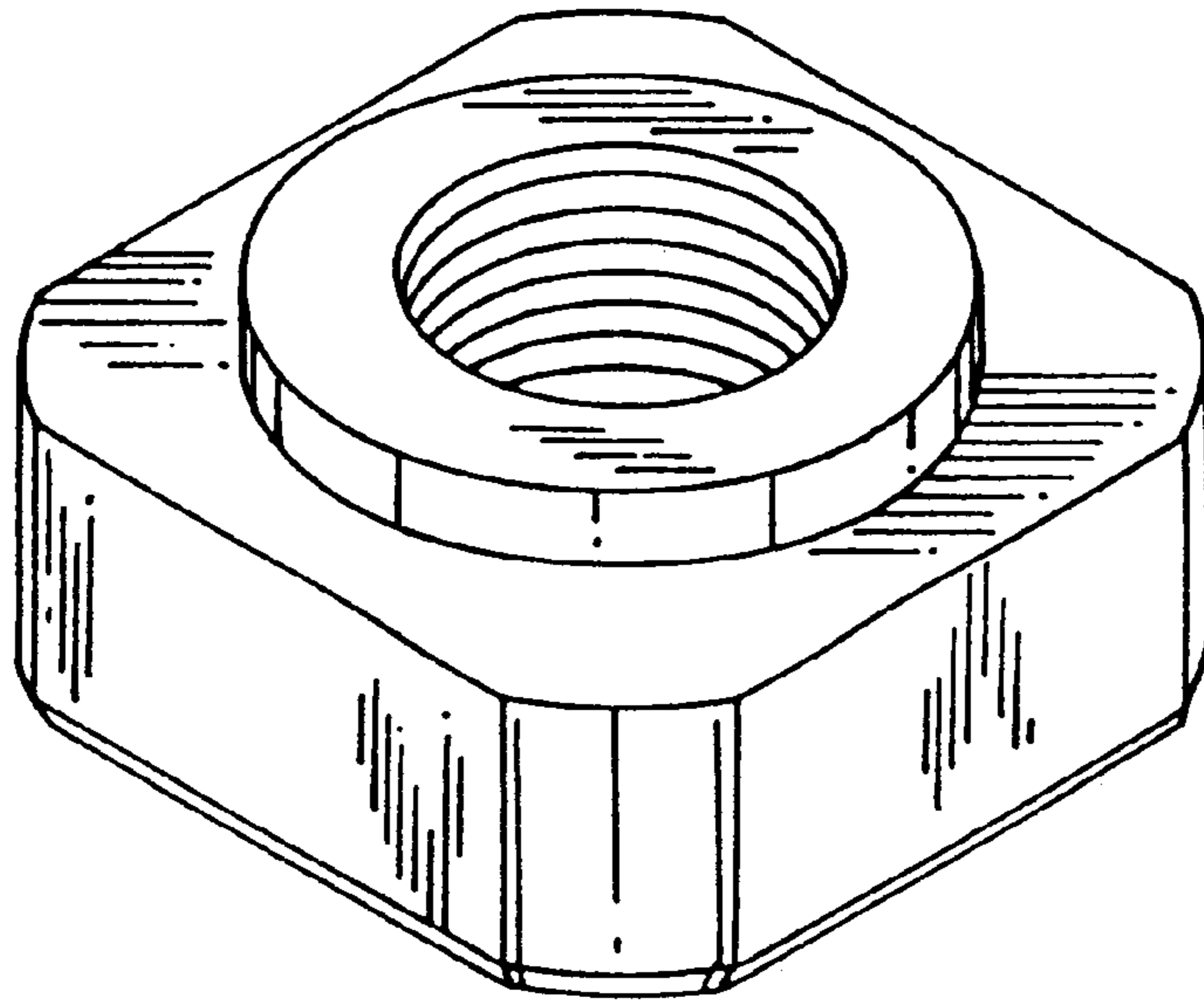

**FIG. 7**

