



US00D451374B1

(12) **United States Design Patent**  
**Shinjo et al.**

(10) **Patent No.:** **US D451,374 S**

(45) **Date of Patent:** **\*\* Dec. 4, 2001**

(54) **CLINCH NUT**

(75) Inventors: **Katsumi Shinjo**, Osaka; **Tadashi Shinjo**, Sakai; **Hiroshi Shinjo**, Osaka, all of (JP)

(73) Assignee: **Yugenkaisha Shinjo Seisakusho**, Osaka (JP)

(\* ) Notice: This patent is subject to a terminal disclaimer.

(\*\*) Term: **14 Years**

(21) Appl. No.: **29/131,925**

(22) Filed: **Oct. 31, 2000**

(30) **Foreign Application Priority Data**

May 18, 2000 (JP) ..... 12-013083

(51) **LOC (7) Cl.** ..... **08-08**

(52) **U.S. Cl.** ..... **D8/397**

(58) **Field of Search** ..... D8/397, 399; 411/172, 411/174, 175, 179, 184, 427, 429, 432, 533, 978, 190, 910, 330, 326, 205, 222

(56) **References Cited**

**U.S. PATENT DOCUMENTS**

32,880 \* 7/1861 Lawrence et al. .  
433,730 \* 8/1890 Harker .

843,656 \* 2/1907 Andersen .  
5,092,725 \* 3/1992 Aittama ..... 411/429  
5,618,145 \* 4/1997 Kuo ..... 411/432

**OTHER PUBLICATIONS**

Machine Design—The Fasteners Book; p. 133; Shakeproof Locknut w/flange, Sep. 29, 1960.\*  
Machine Design—The Fasteners Book; p. 138; Rh nut, Sep. 9, 1960.\*

\* cited by examiner

*Primary Examiner*—B. J. Bullock

(74) *Attorney, Agent, or Firm*—Antonelli, Terry, Stout & Kraus, LLP

(57) **CLAIM**

The ornamental design for a clinch nut, as shown and described.

**DESCRIPTION**

FIG. 1 is a top plan view;  
FIG. 2 is a front elevation;  
FIG. 3 is a bottom plan view;  
FIG. 4 is a right-side elevation;  
FIG. 5 is a cross section taken along the line 5—5 in FIG. 1;  
FIG. 6 is a downwards perspective view; and,  
FIG. 7 is an upwards perspective view.

**1 Claim, 3 Drawing Sheets**

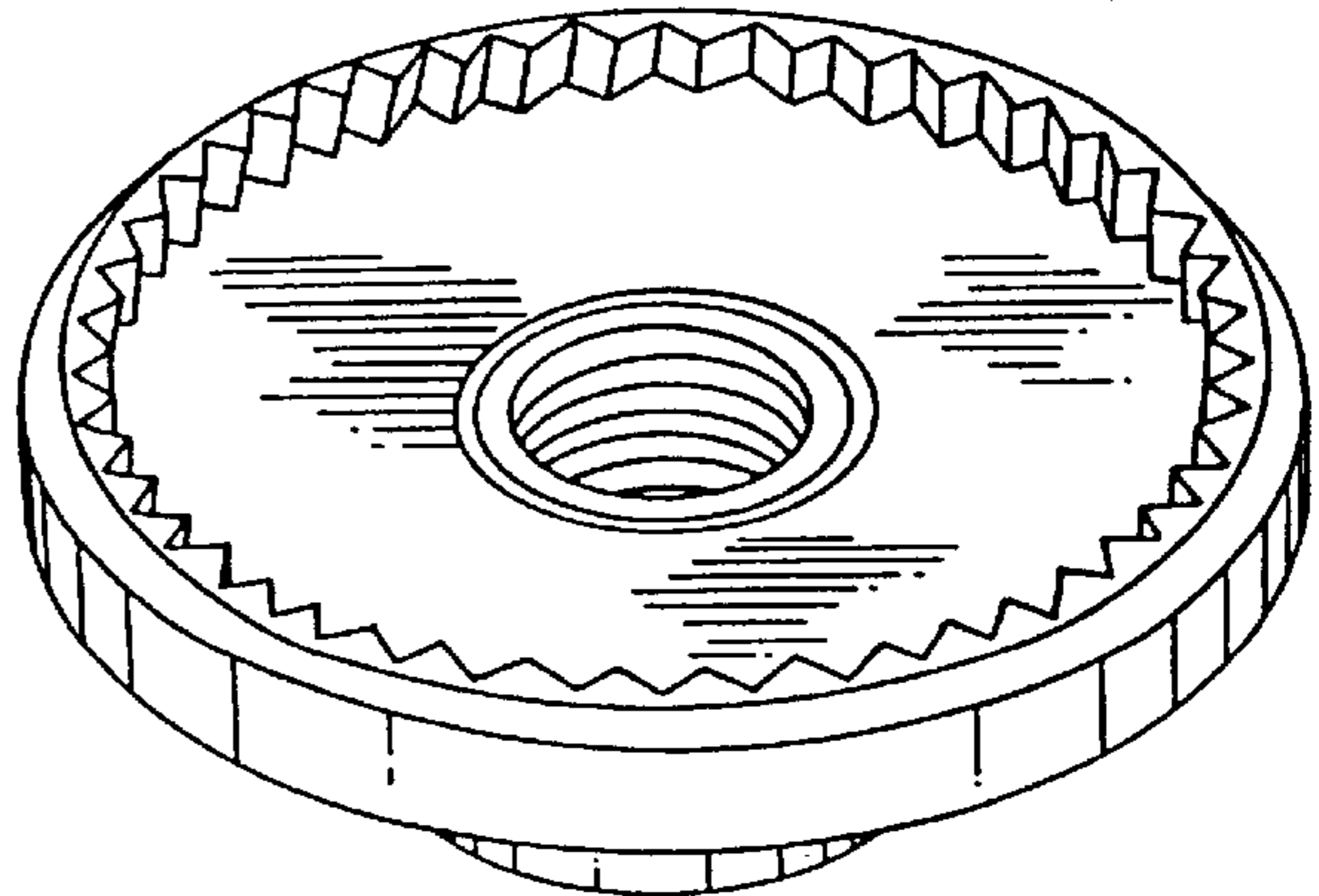
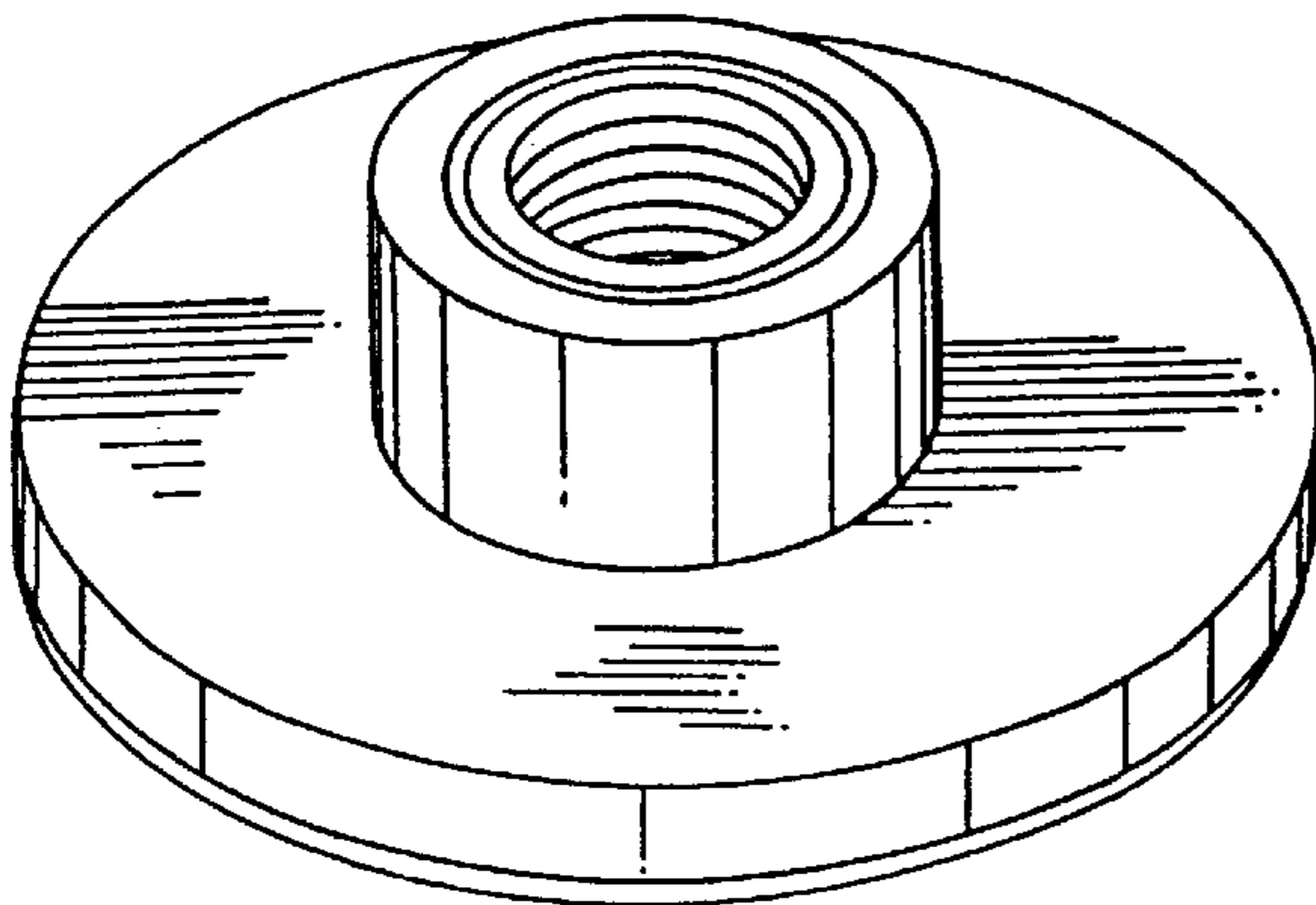

FIG. 1

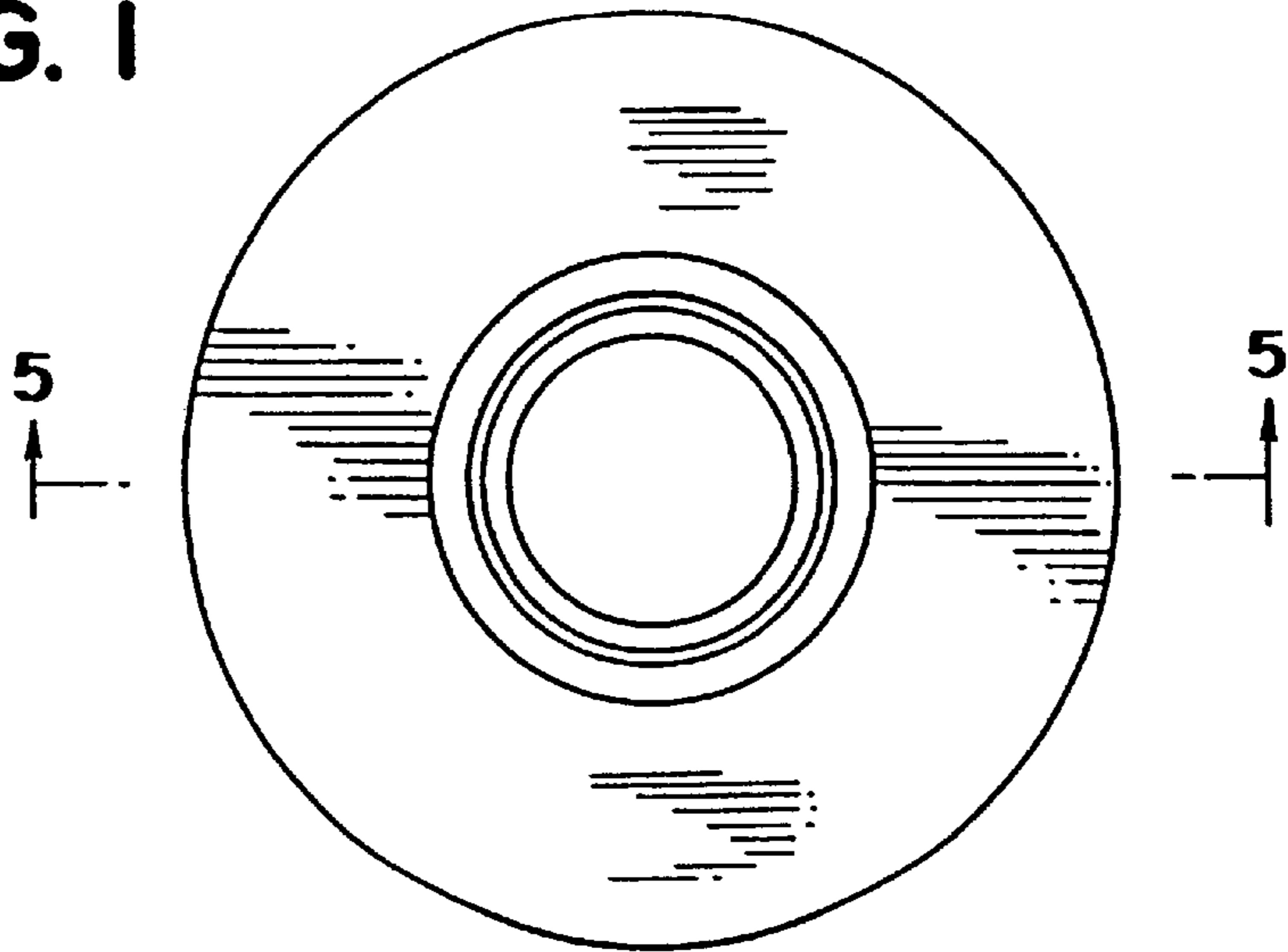

FIG. 2

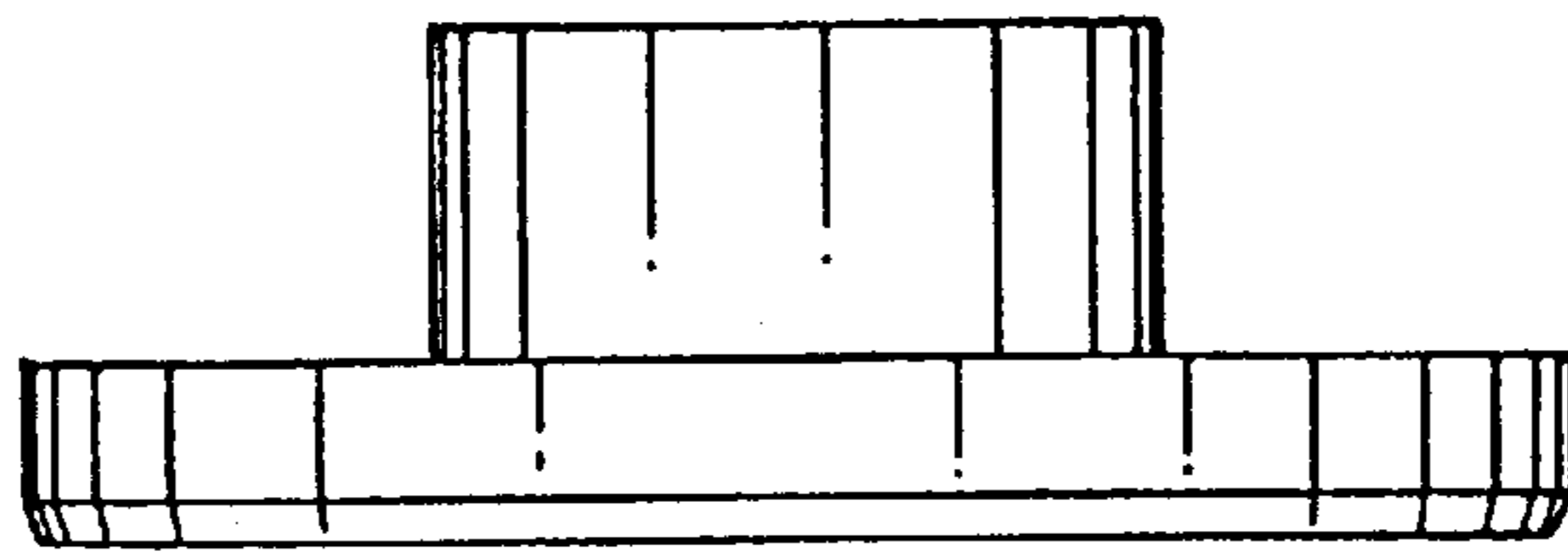
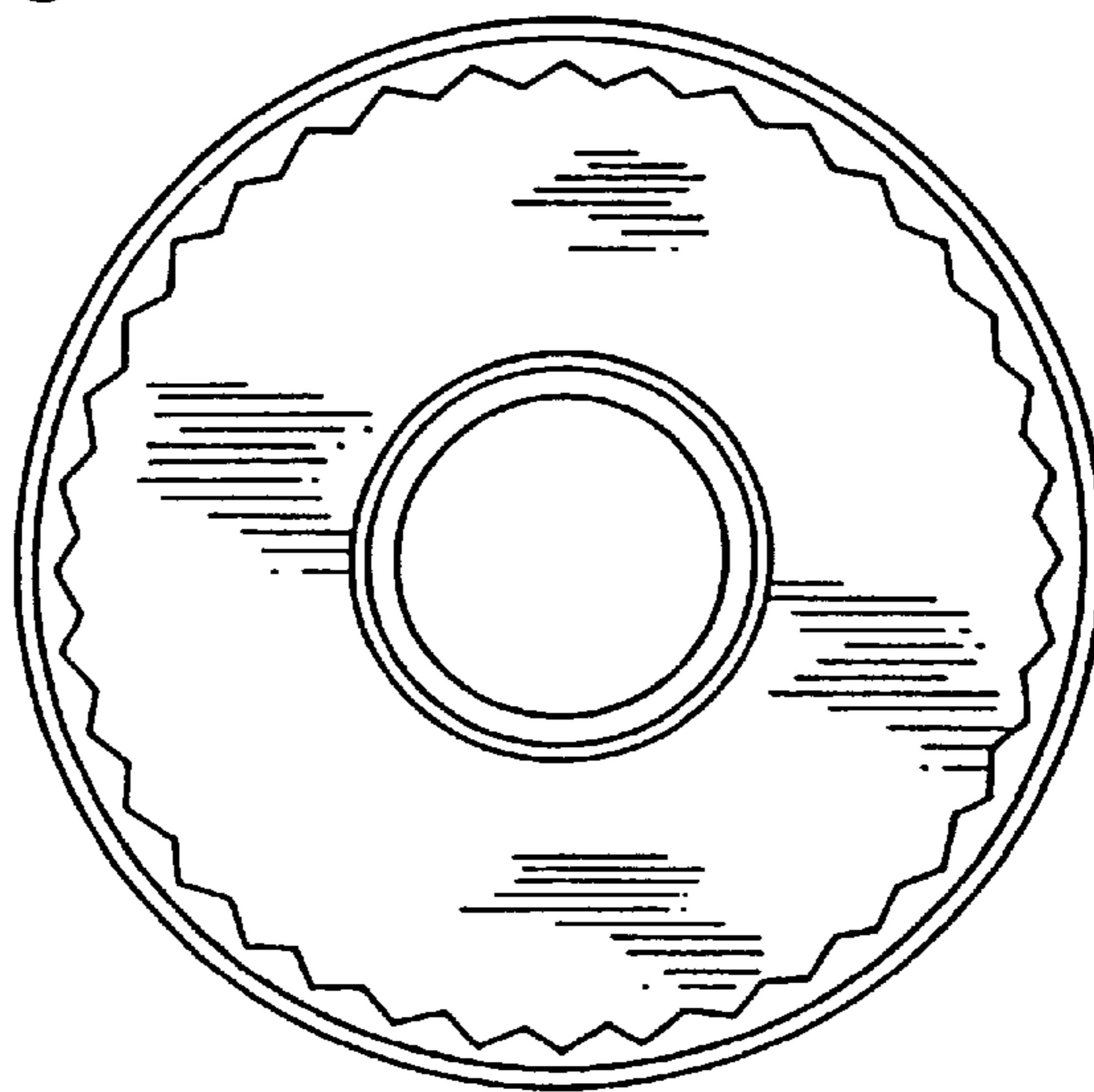
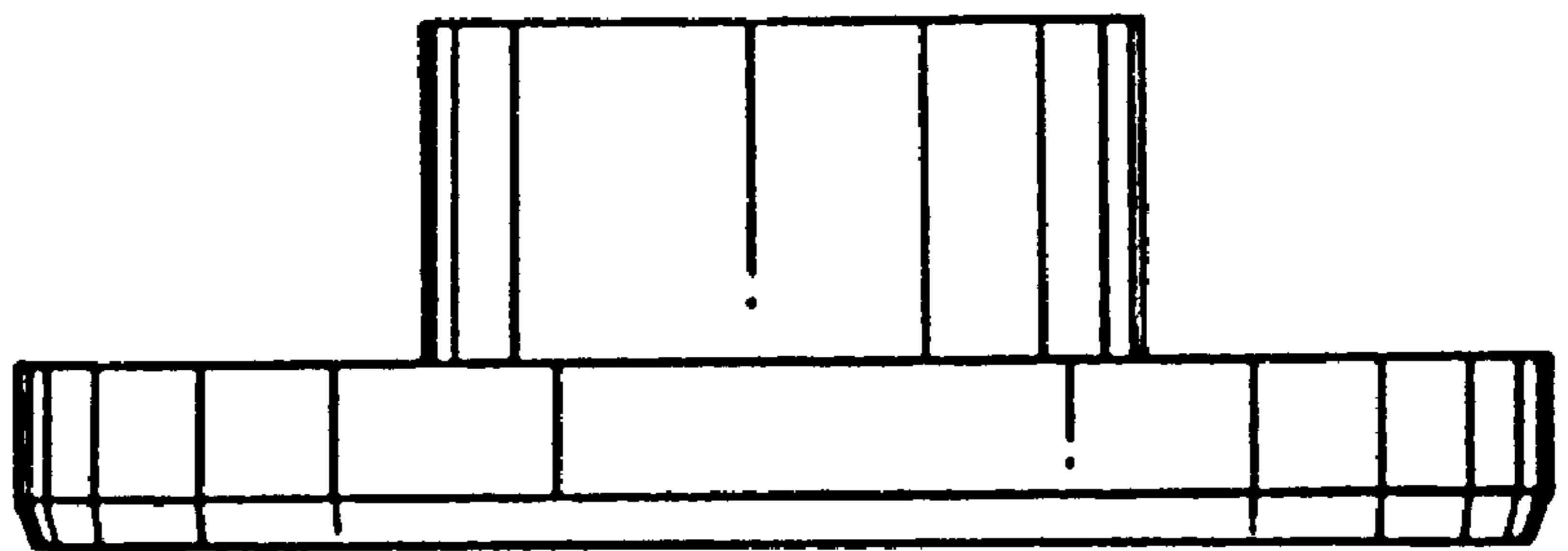

FIG. 3



**FIG. 4**



**FIG. 5**

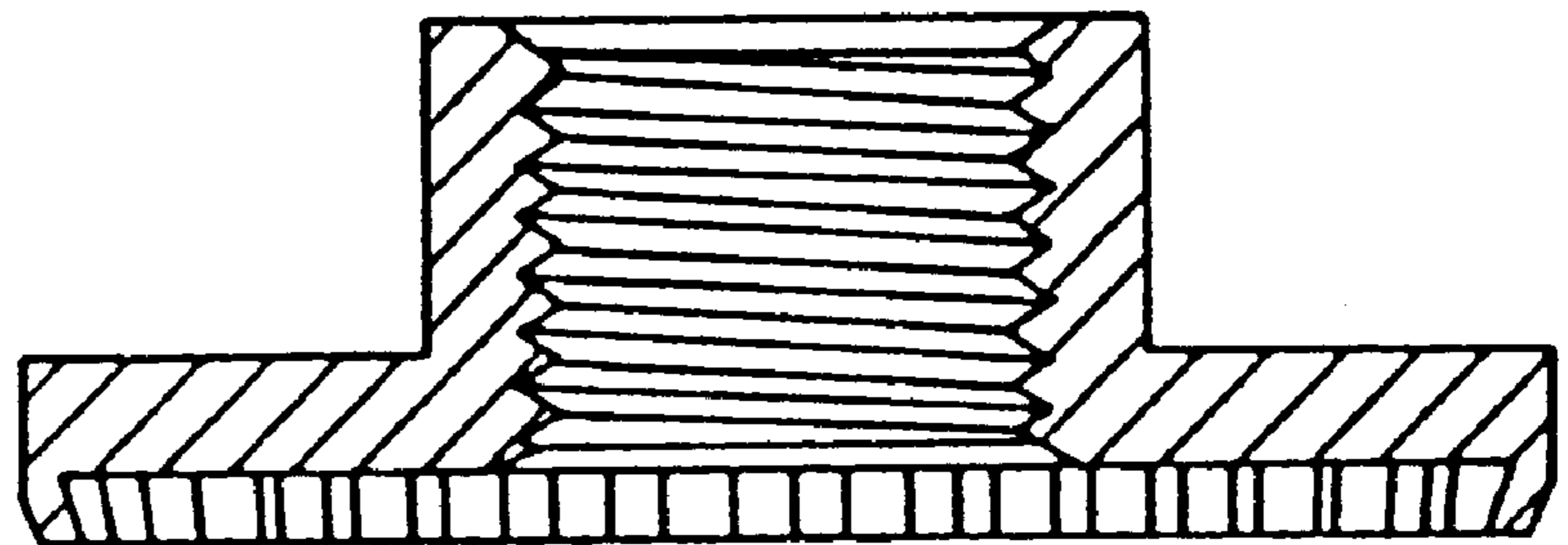

**FIG. 6**

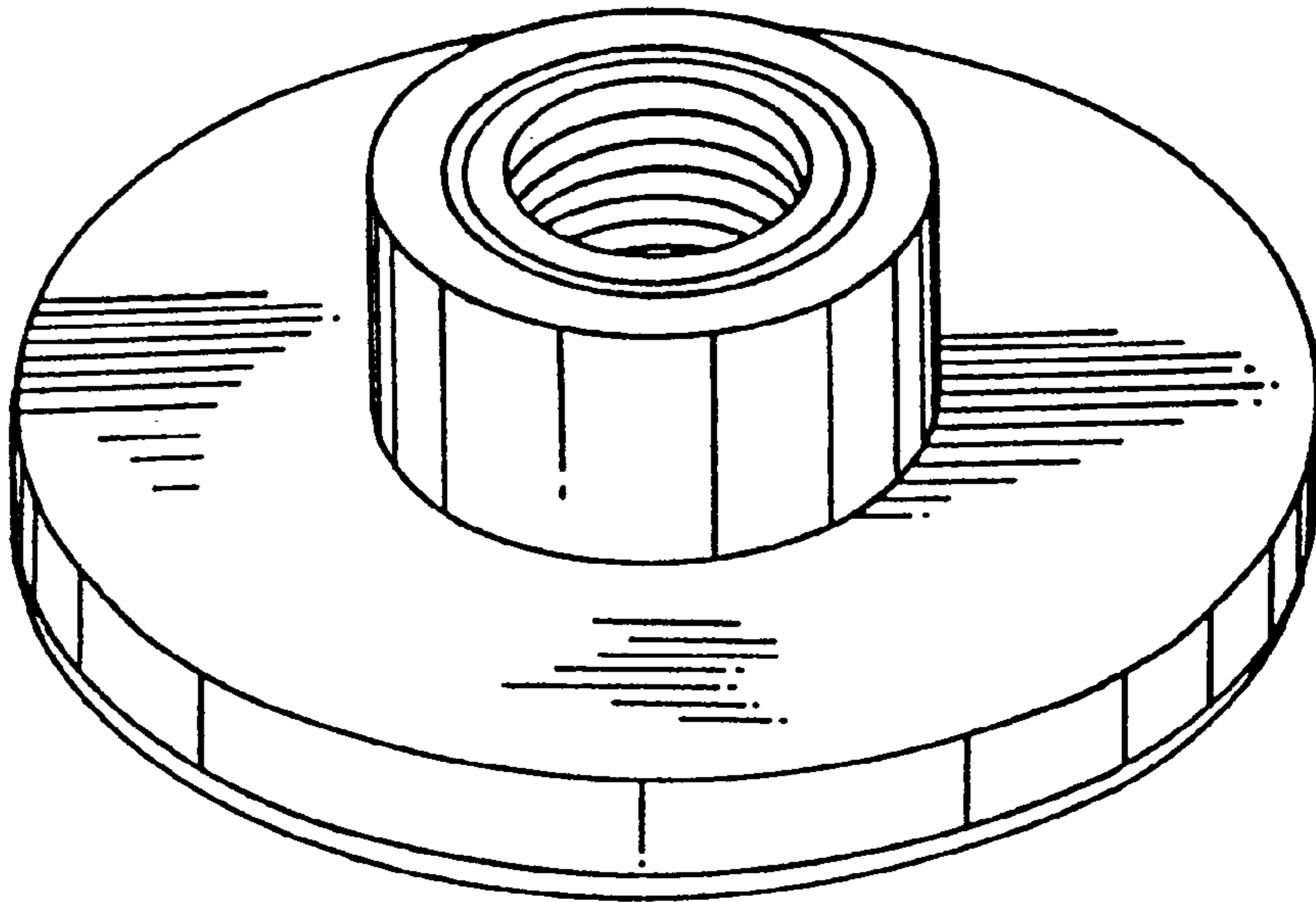

**FIG. 7**

