



US00D451050B1

(12) **United States Design Patent**  
**Cerny, Jr. et al.**

(10) **Patent No.: US D451,050 S**  
(45) **Date of Patent: \*\* Nov. 27, 2001**

(54) **VEHICLE CHASSIS SURFACE**

(75) Inventors: **John Robert Cerny, Jr.; Mohamad Samih El-Zein**, both of Bettendorf, IA (US); **Harold Eugene Krause**, Milan; **Richard Lane Hockenberry, Viola**, both of IL (US)

(73) Assignee: **Deere & Company**, Moline, IL (US)

(\*\*) Term: **14 Years**

(21) Appl. No.: **29/118,944**

(22) Filed: **Feb. 18, 2000**

(51) **LOC (7) Cl. .... 12-08**

(52) **U.S. Cl. .... D12/86; D12/107; D12/16**

(58) **Field of Search .... D12/86, 107, 16, D12/15, 14; 296/185**

(56) **References Cited**

**U.S. PATENT DOCUMENTS**

D. 311,921	11/1990	Popelier et al. ....	D15/15
D. 338,473	8/1993	Patterson et al. ....	D15/17
D. 395,023 *	6/1998	Hikida ....	D12/16
D. 441,320 *	5/2001	Kehr ....	D12/16
5,174,627	12/1992	Cleereman et al. ....	296/187
5,238,267	8/1993	Hutchison et al. ....	280/781
5,314,230	5/1994	Hutchison et al. ....	296/203
5,558,368	9/1996	Cerny et al. ....	280/781

**OTHER PUBLICATIONS**

John Deere, John Deere Gator® 6×4 and 4×2 Utility Vehicles brochure, 12 pages, date of publication—Mar. 1993, published in U.S.A.

Club Car Inc., Drive It To Work brochure, 2 pages, dated Feb. 1994, published in U.S.A.

(List continued on next page.)

*Primary Examiner*—Melody N. Brown

**1 Claim, 10 Drawing Sheets**

(57) **CLAIM**

The ornamental design for a vehicle chassis surface, as shown and described.

**DESCRIPTION**

FIG. 1 is an elevated left front perspective view of a vehicle chassis surface showing our new design, the broken line showings of the front, mid and rear compartments being for illustrative purposes only, and forming no part of the claimed design.

FIG. 2 is an elevated rear left perspective view of the vehicle chassis surface design of FIG. 1.

FIG. 3 is a plan view of the vehicle chassis surface design of FIG. 1.

FIG. 4 is a left side view of the vehicle chassis surface design of FIG. 1.

FIG. 5 is a right side view of the vehicle chassis surface design of FIG. 1.

FIG. 6 is a front view of the vehicle chassis surface design of FIG. 1.

FIG. 7 is a rear view of the vehicle chassis surface design of FIG. 1.

FIG. 8 is an elevated left front perspective view of a vehicle chassis surface showing a second embodiment of our new design, the broken line showings of the front, mid and rear compartments being for illustrative purposes only, and forming no part of the claimed design.

FIG. 9 is an elevated rear left perspective view of the vehicle chassis surface design of FIG. 8.

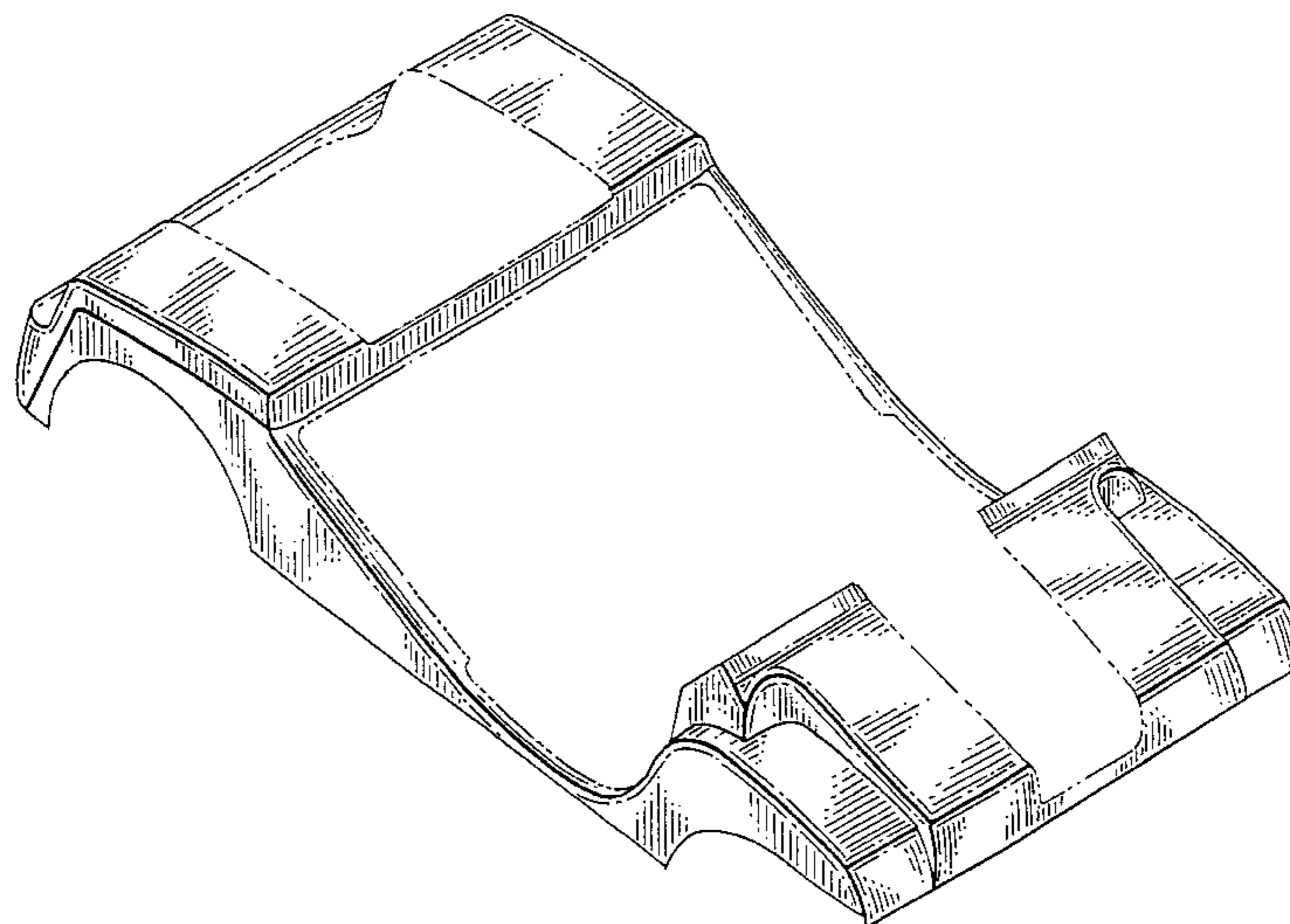
FIG. 10 is a plan view of the vehicle chassis surface design of FIG. 8.

FIG. 11 is a left side view of the vehicle chassis surface design of FIG. 8.

FIG. 12 is a right side view of the vehicle chassis surface design of FIG. 8.

FIG. 13 is a front view of the vehicle chassis surface design of FIG. 8; and,

FIG. 14 is a rear view of the vehicle chassis surface design of FIG. 8.



OTHER PUBLICATIONS

Kawasaki Motors Corp., Mule 2010/1000 brochure, 2 pages, date of publication—1990, published in Japan.

Ransomes Cushman Ryan, Cushman Hawk brochure, 2 pages, date of publication—1996, published in U.S.A.

E-Z-Go Textron, E-Z-Go brochure, 2 pages, date of publication—Jul. 1986, published in U.S.A.

Club Car Inc., Club Car brochure, 2 pages, date of publication—unknown, published in U.S.A.

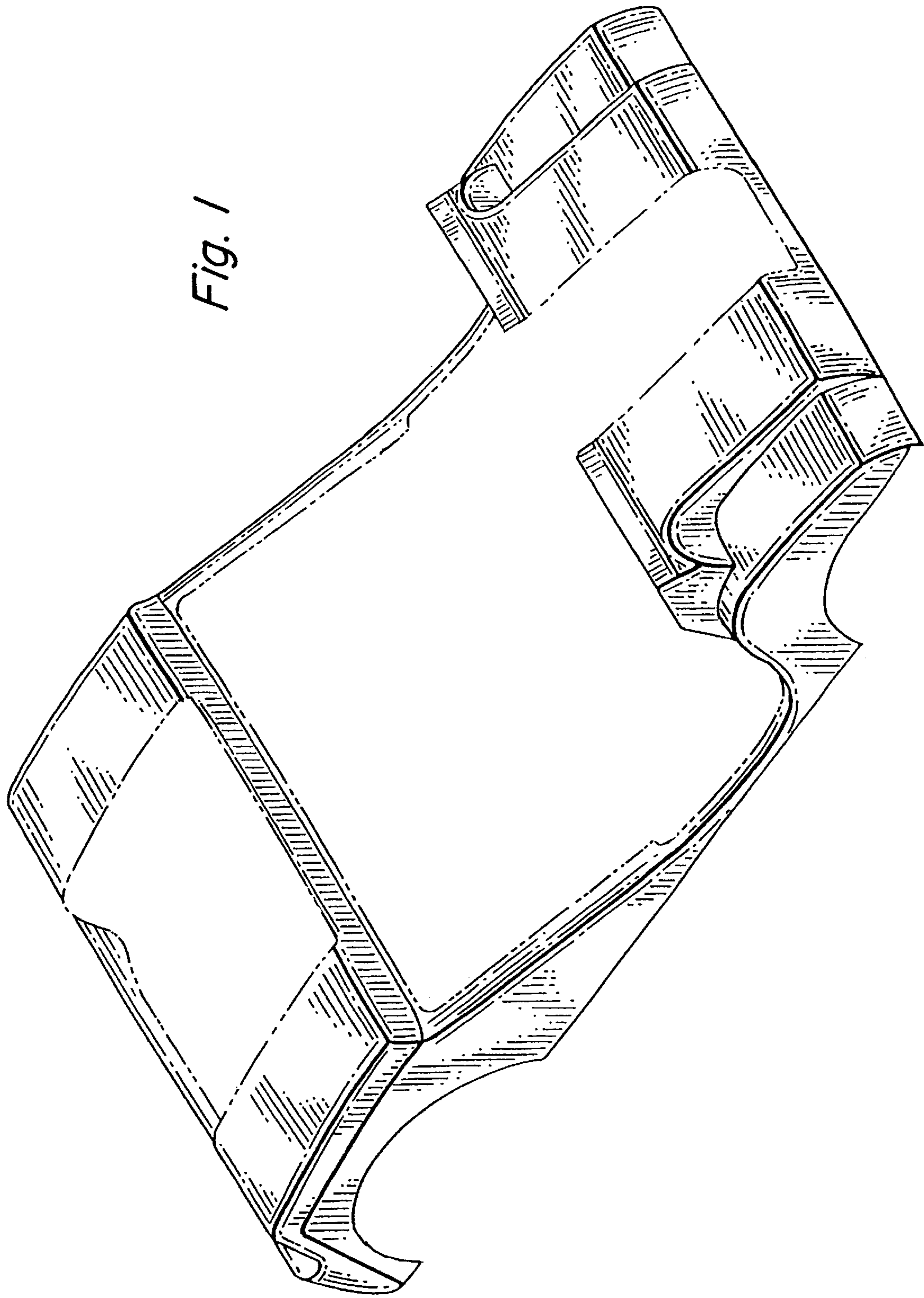
Yamaha Motor Corp., Yamaha brochure, 2 pages, date of publication—unknown, published in U.S.A.

Lamborghini, Golf Cart brochure, 2 pages, dated Nov. 1997, published in Italy.

Shuttlecraft USA Inc., The Golf Car That Evolved From Space Age Technology brochure, 2 pages, dated Feb. 1988, published in U.S.A.

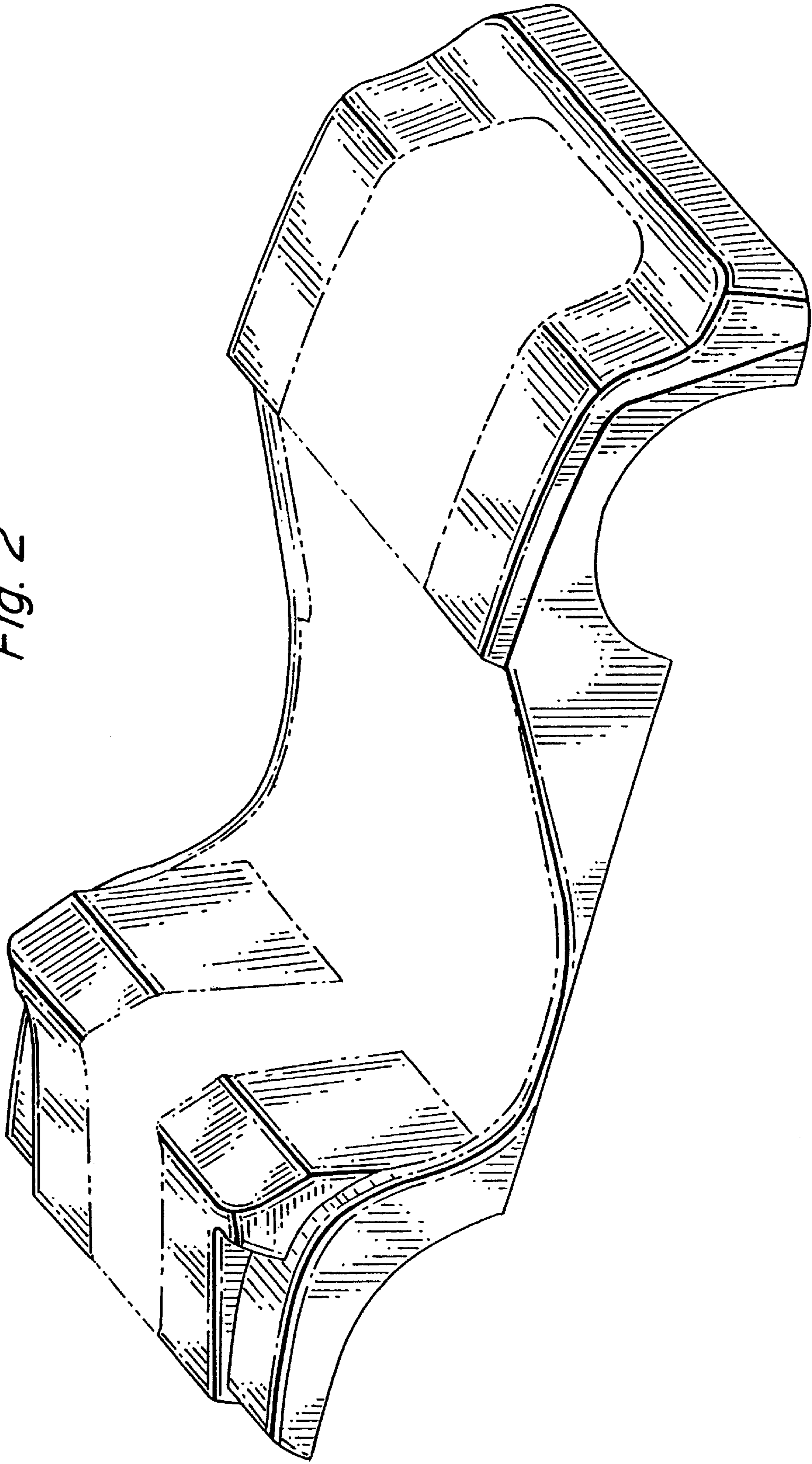
Yamaha Motor Corporation, Pro4 Utility Products brochure, 2 pages, date of publication—1989, published in U.S.A.

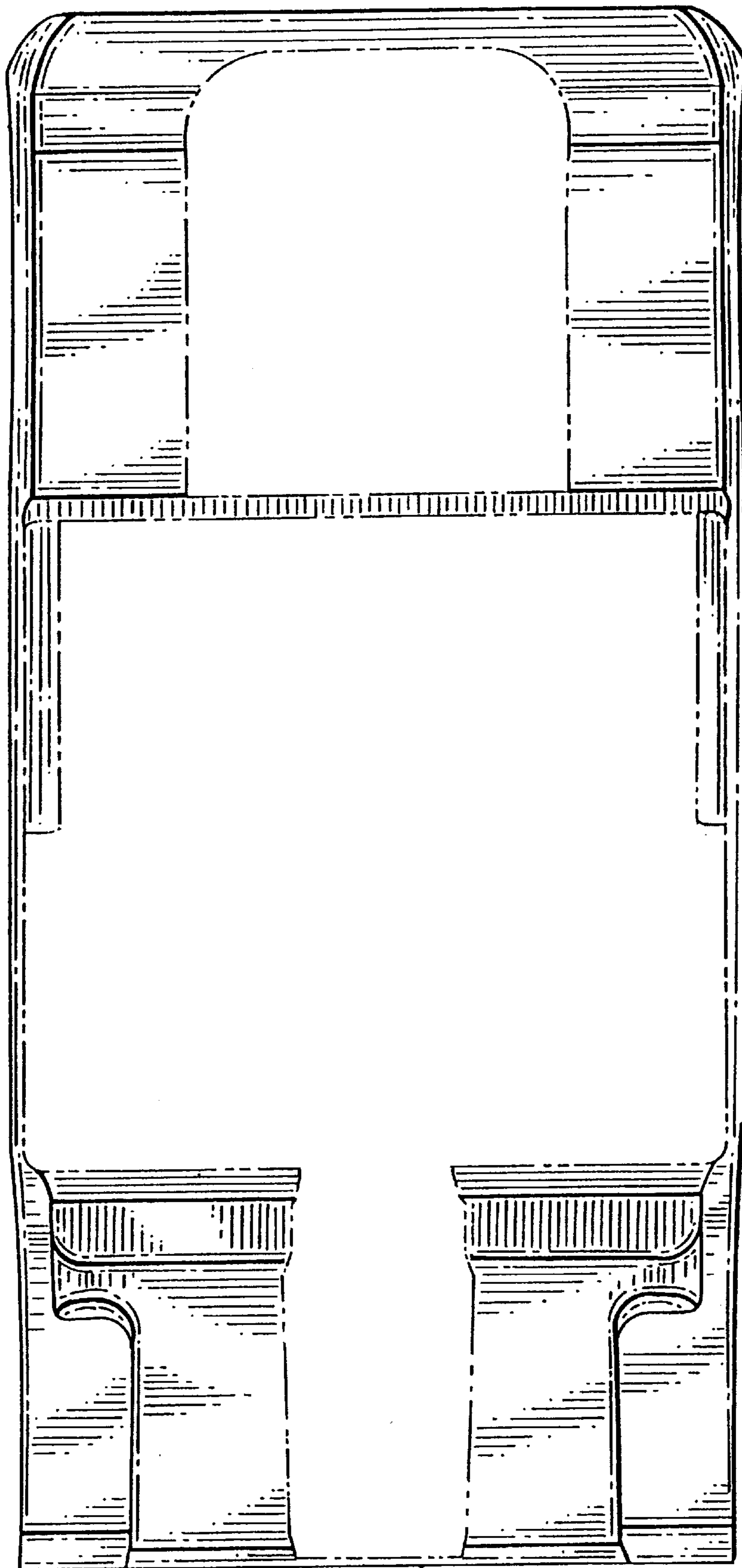
\* cited by examiner



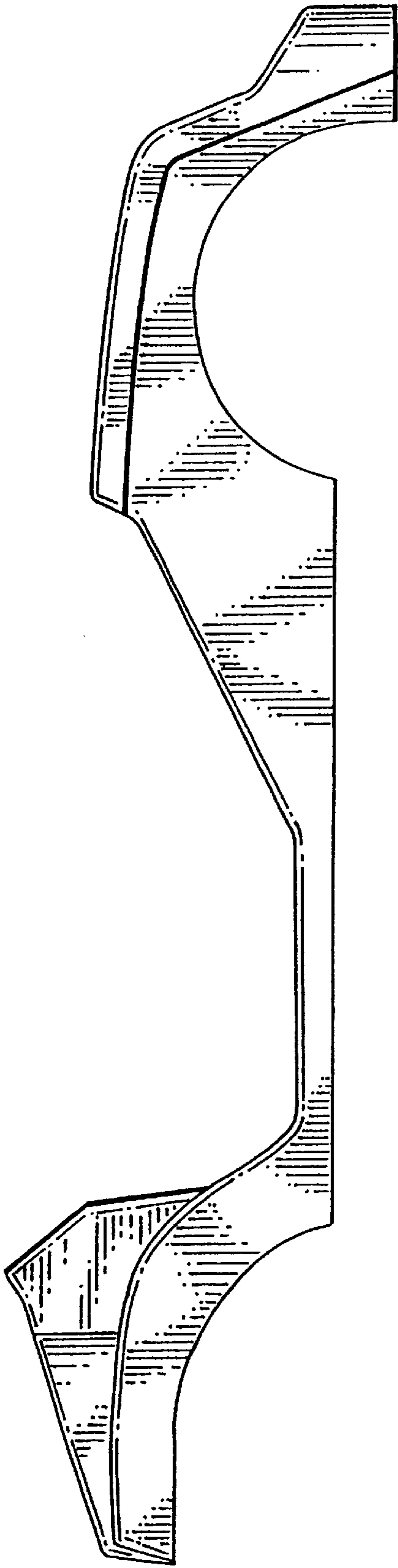
*Fig. 1*

Fig. 2

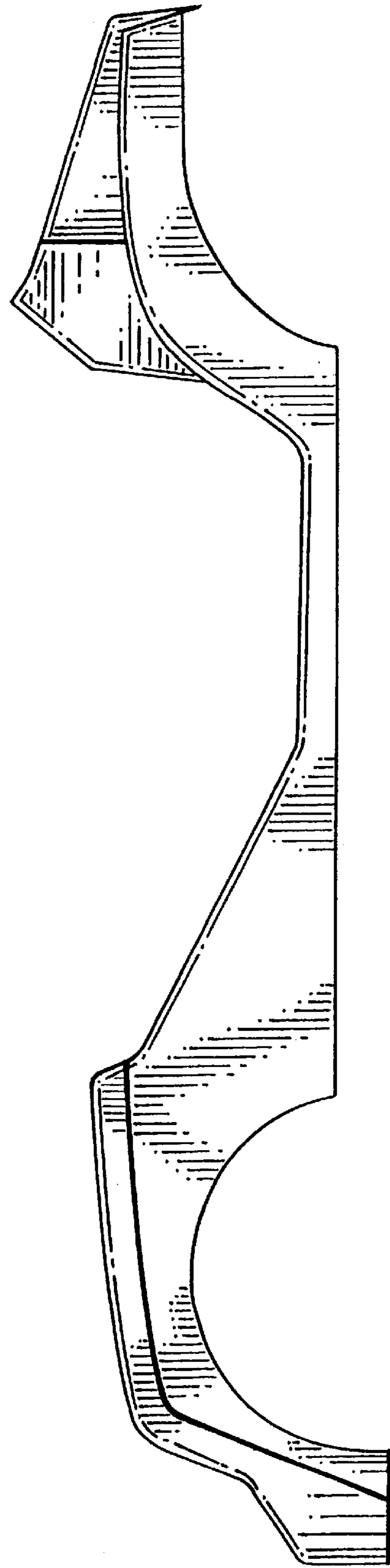




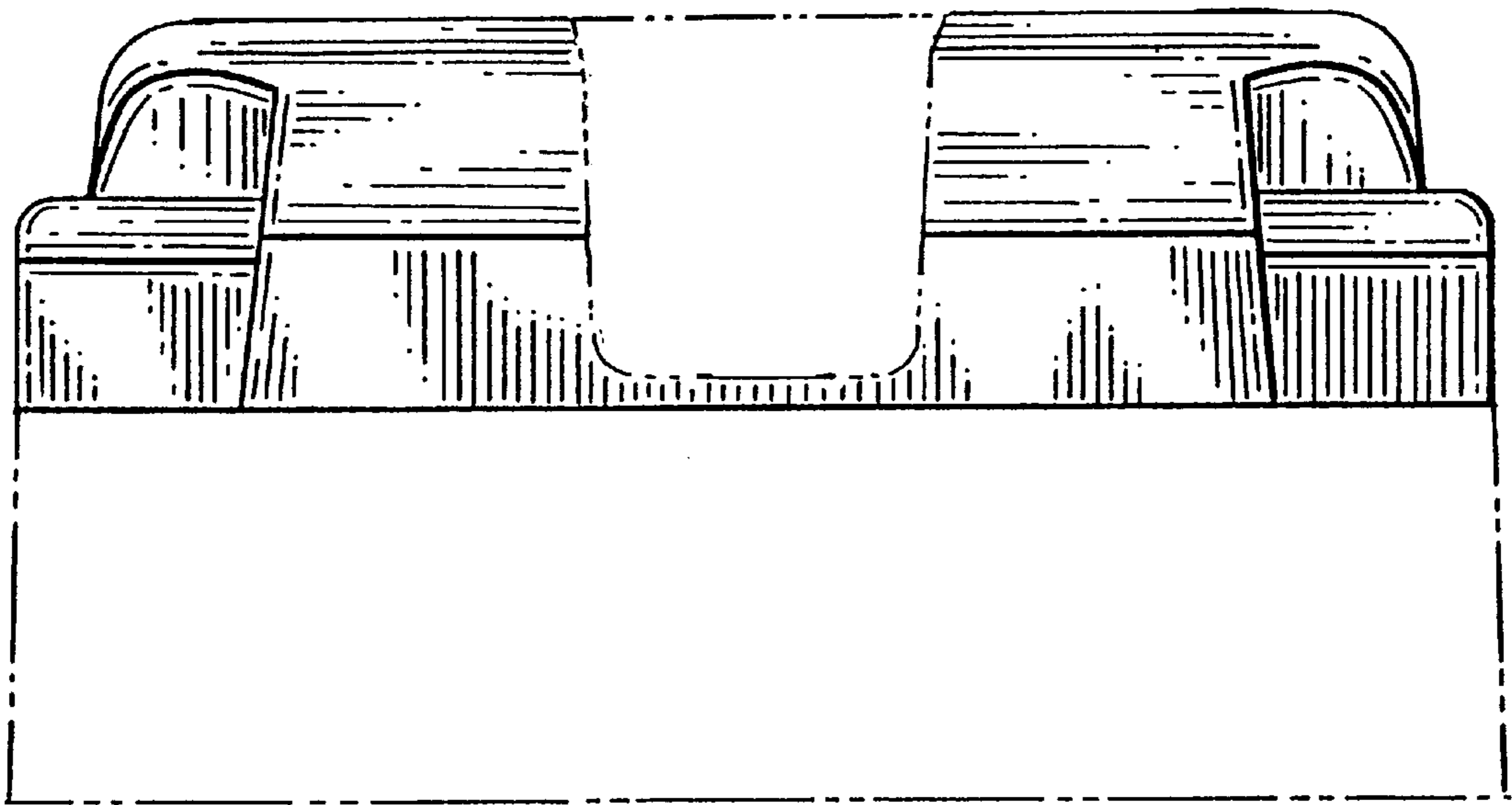
*Fig. 3*



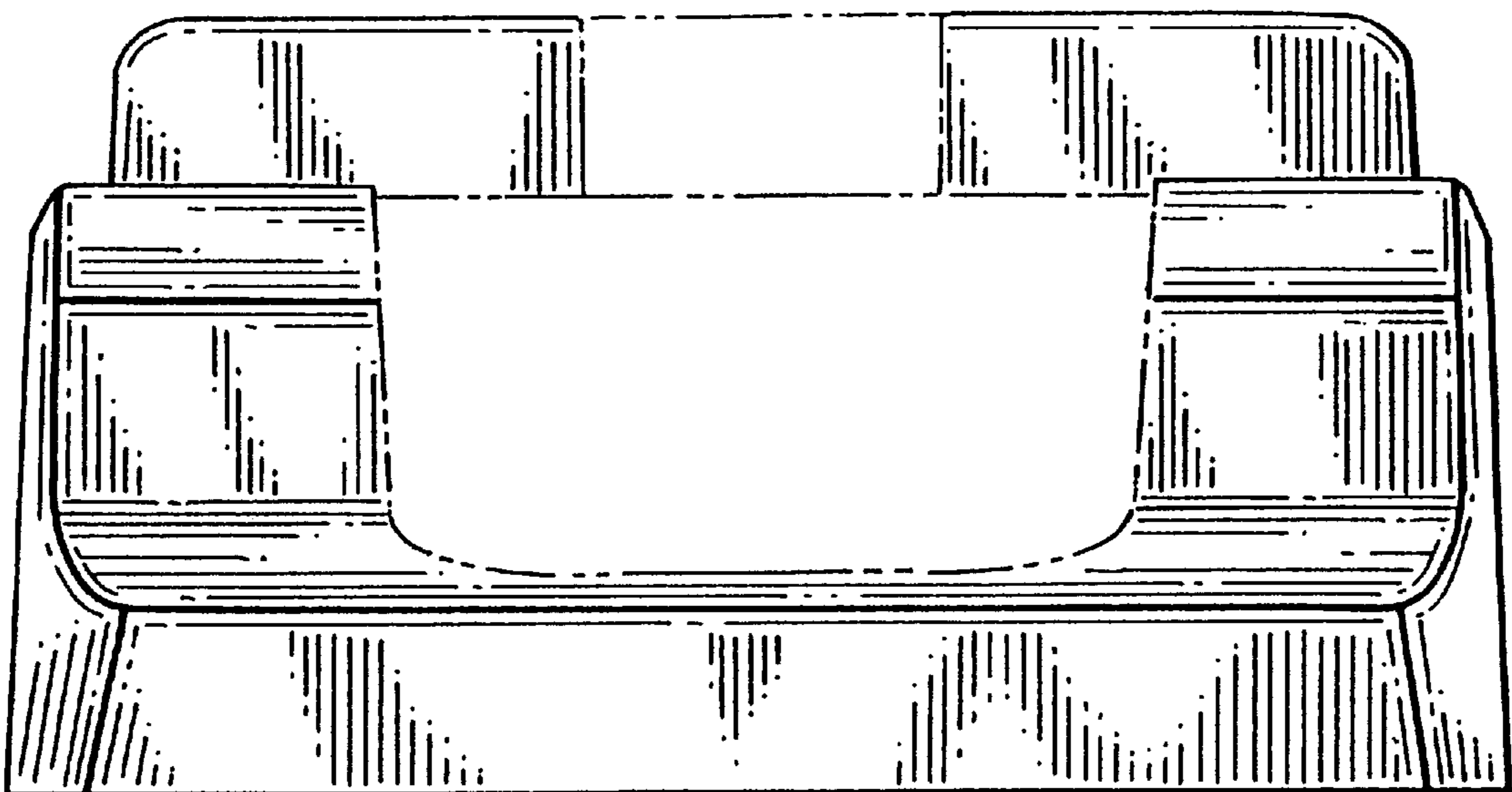
*Fig. 4*



*Fig. 5*

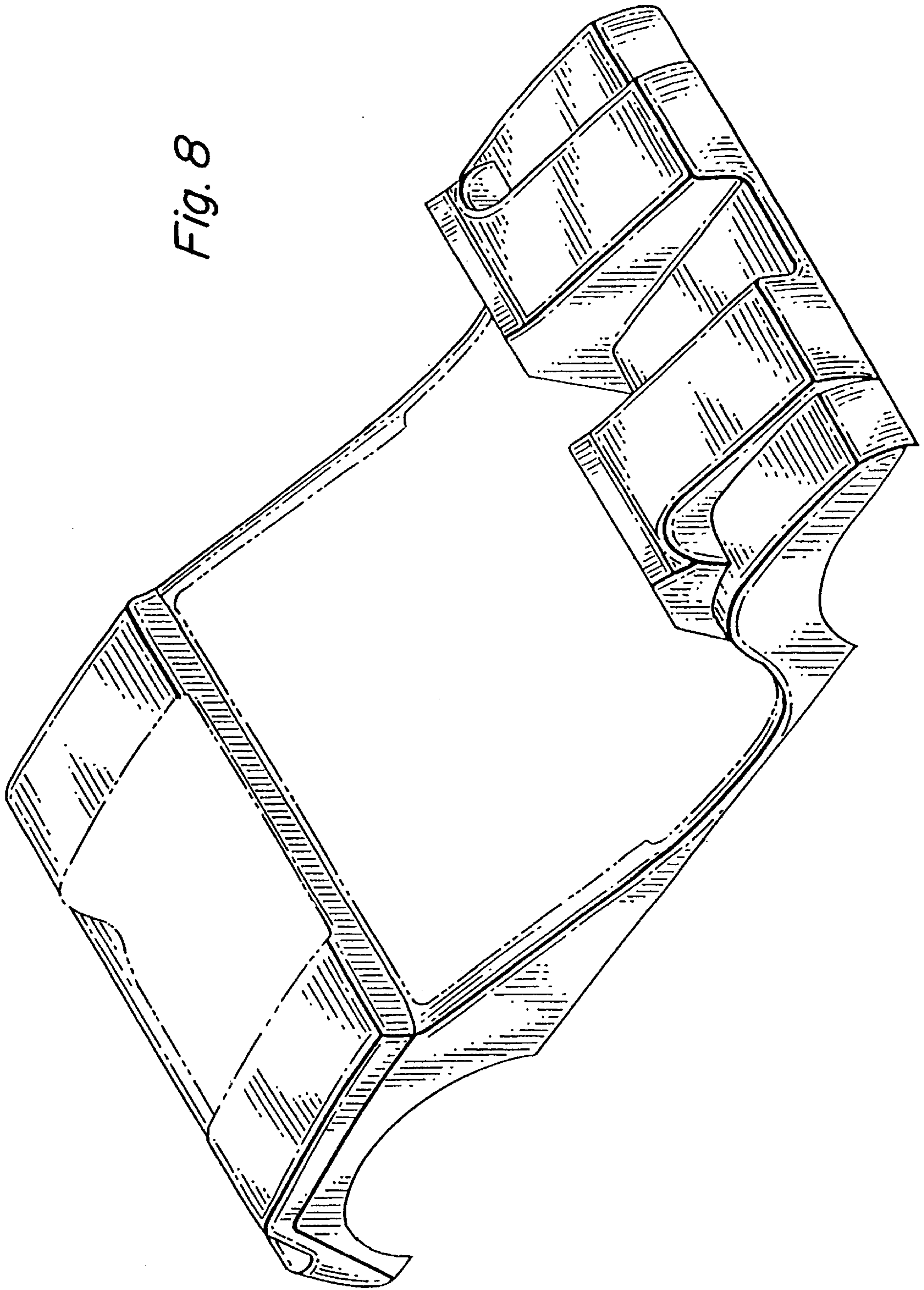


*Fig. 6*



*Fig. 7*

*Fig. 8*





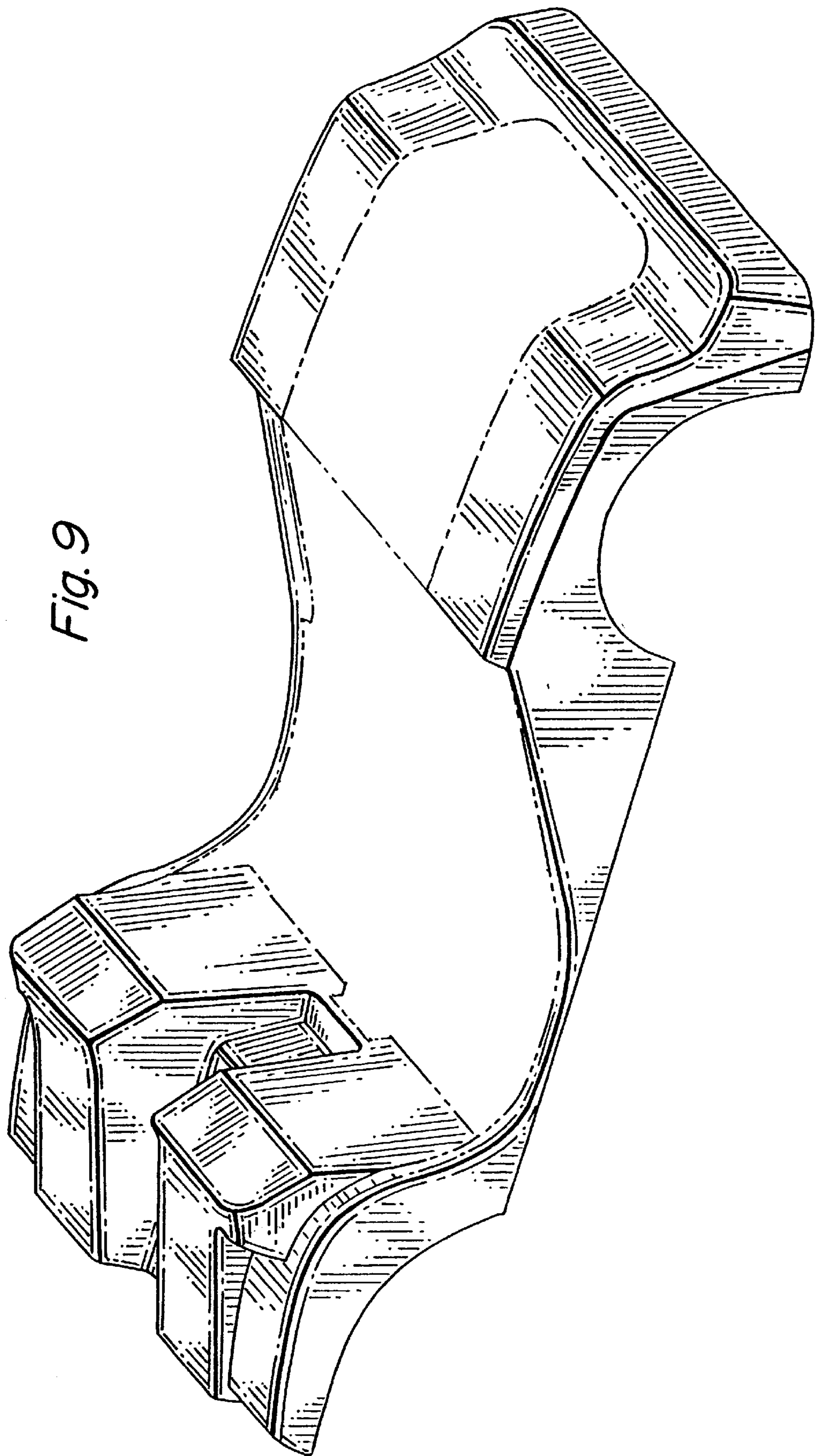
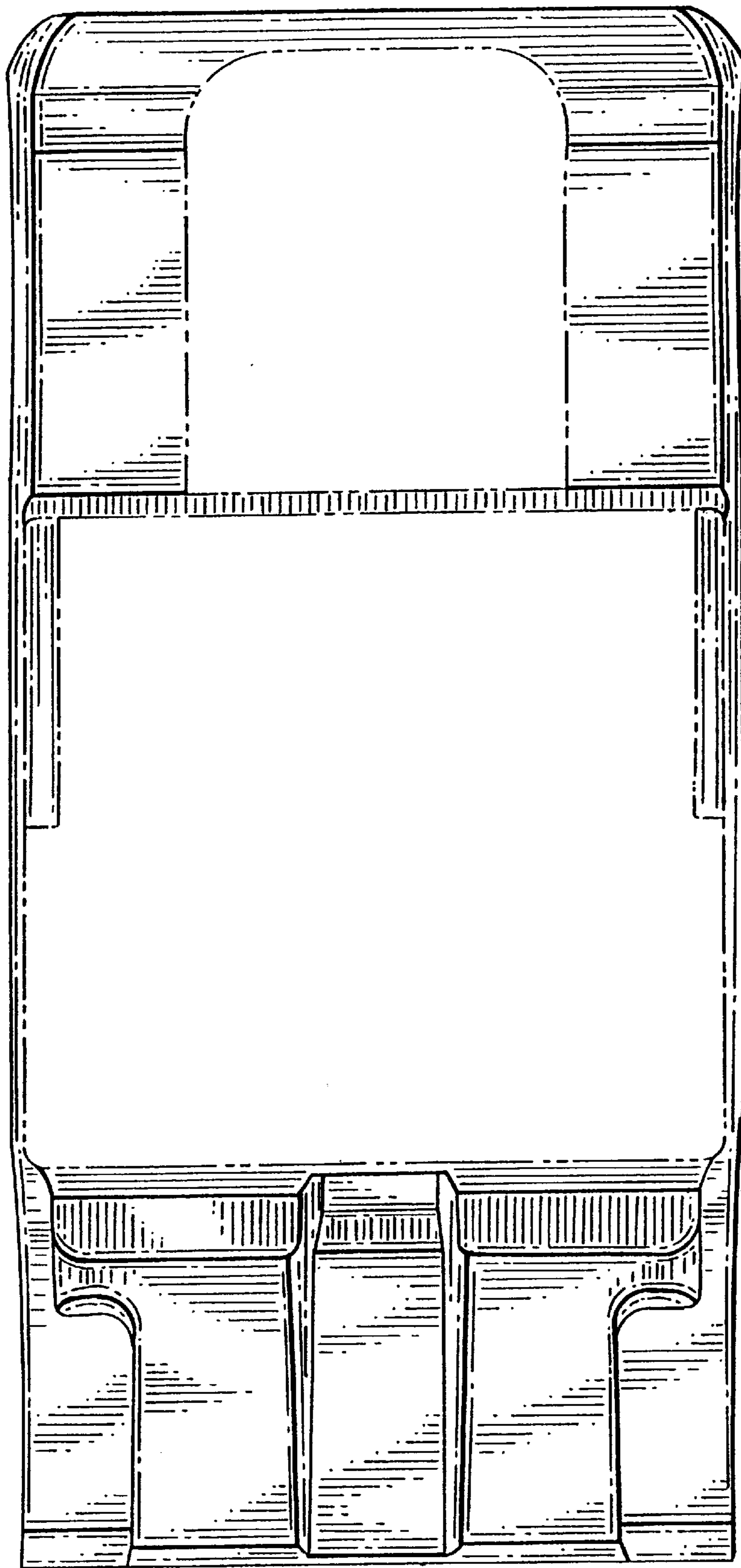
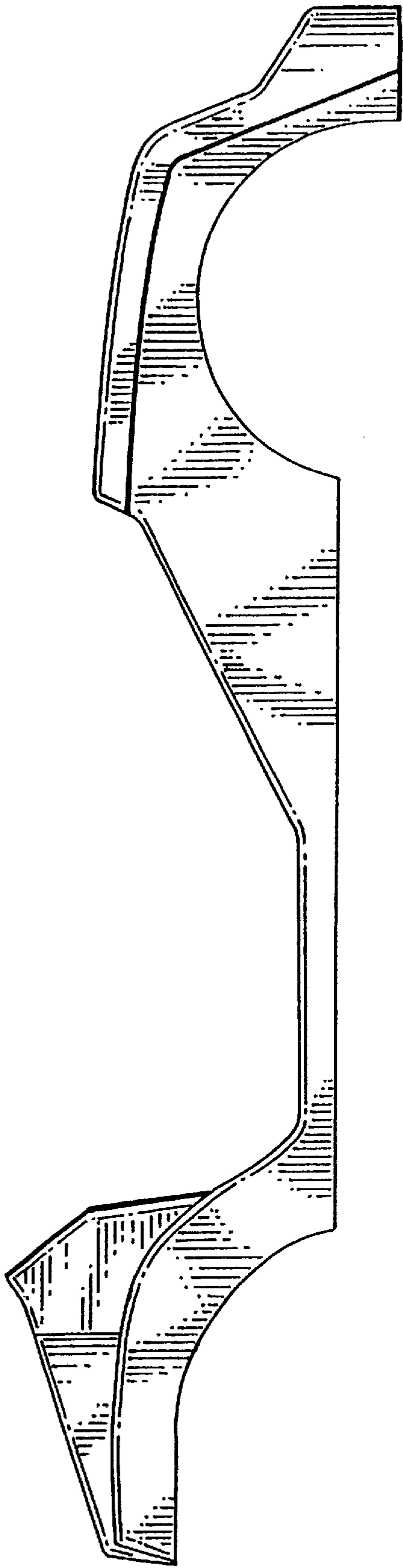


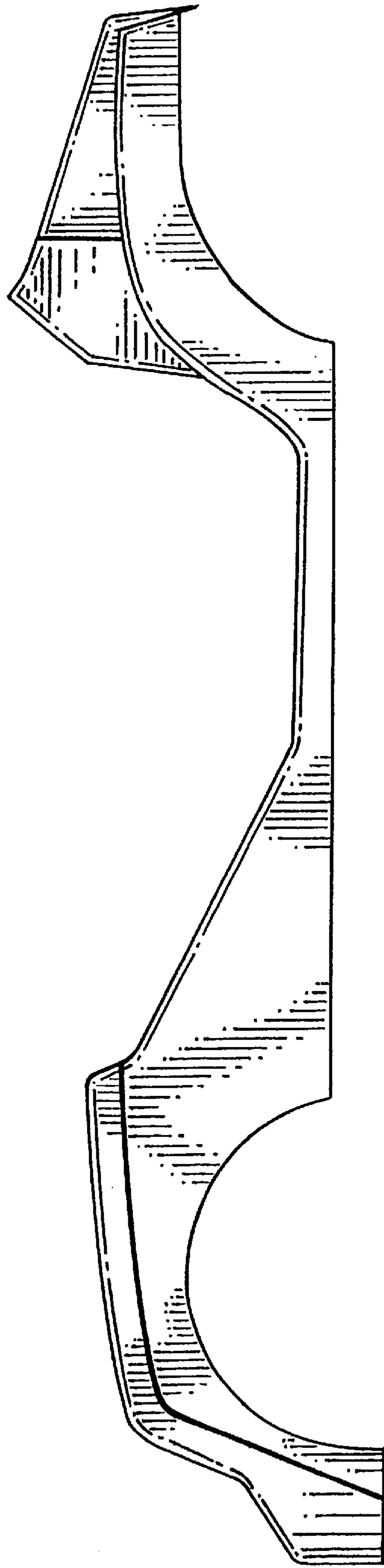
Fig. 9



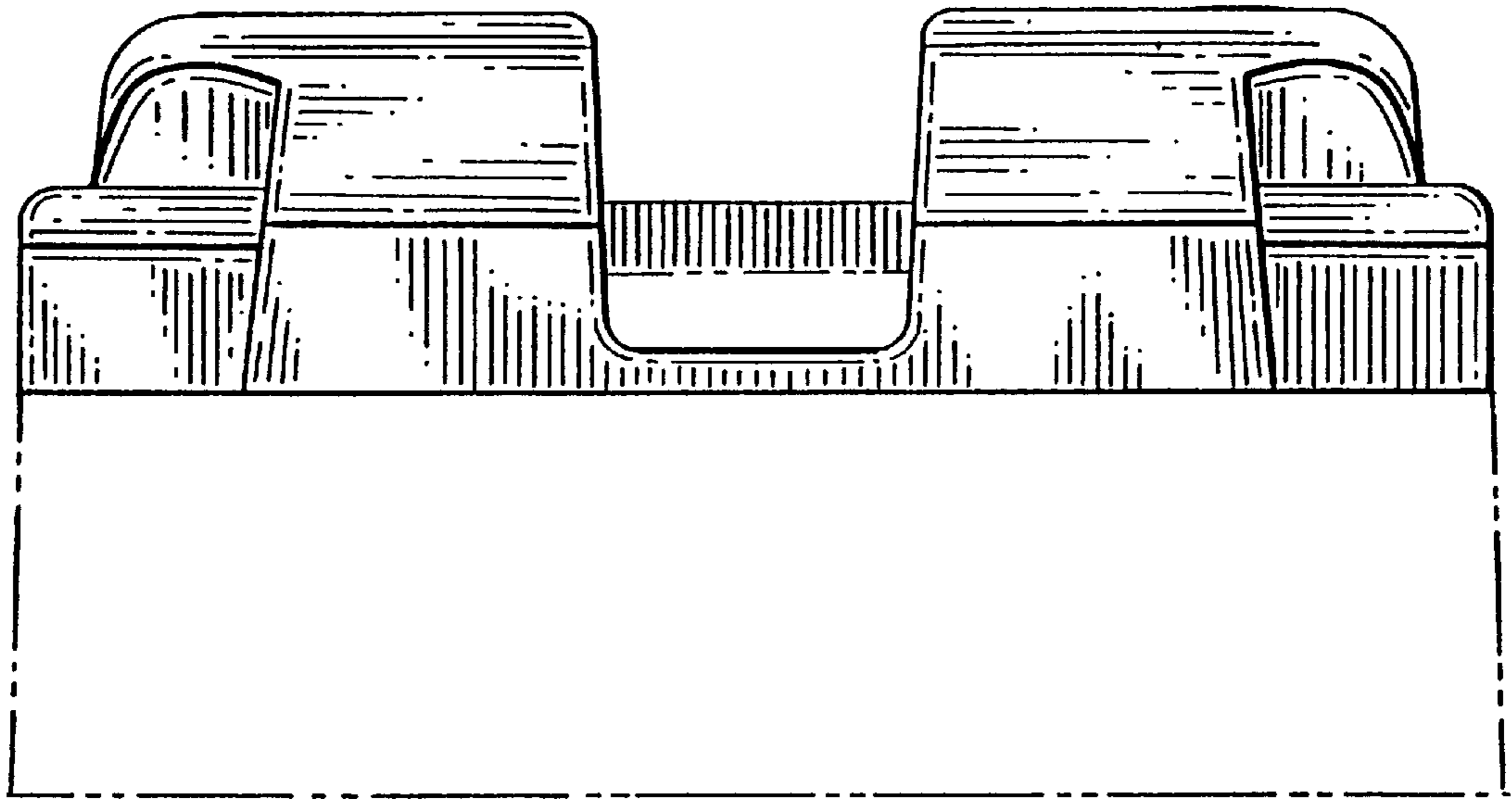
*Fig. 10*



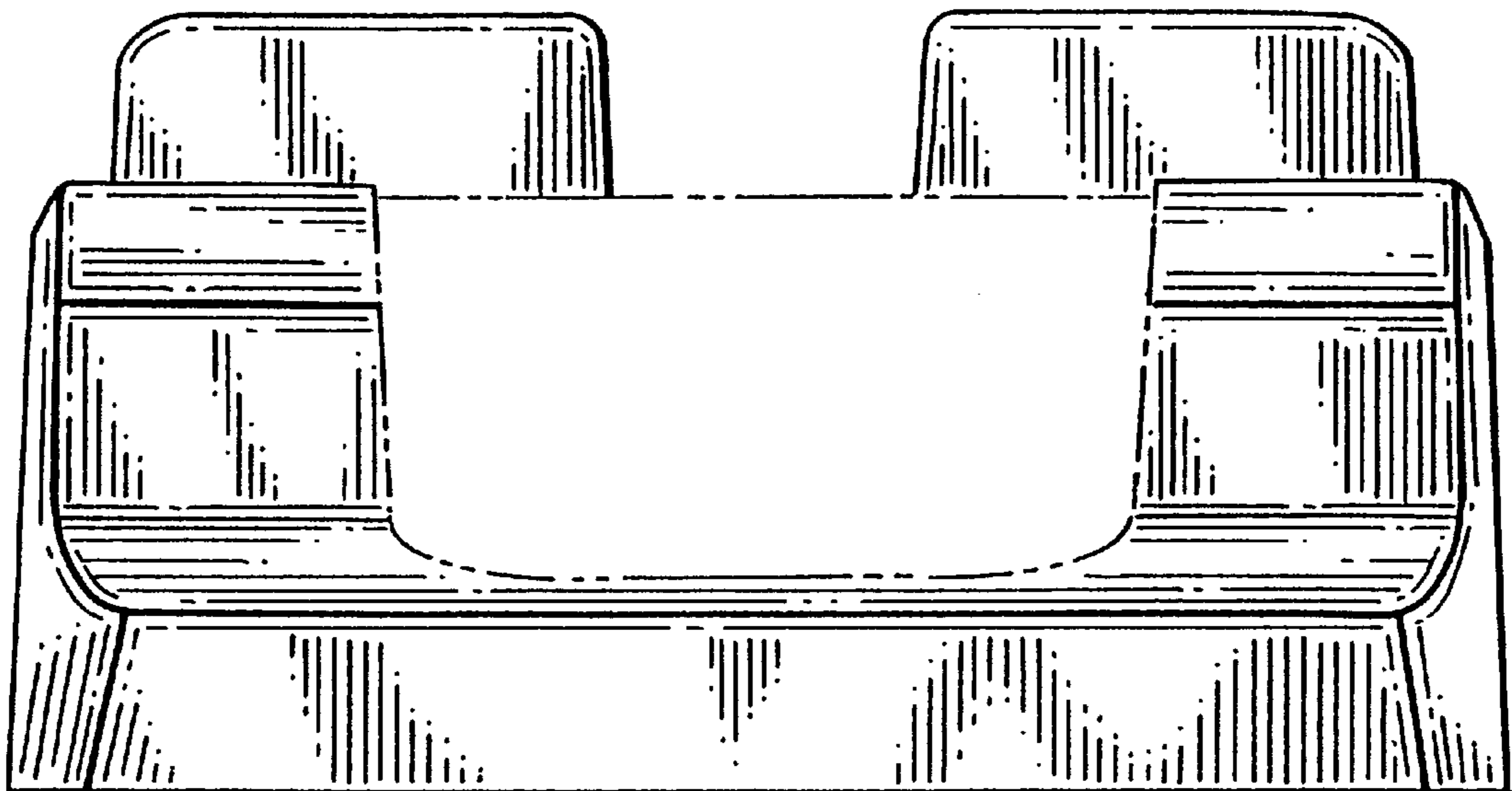
*Fig. 11*



*Fig. 12*



*Fig. 13*



*Fig. 14*